

UNIVERSITY OF ZAMBIA

SCHOOL OF MINES

FIRST SEMESTER

2009-2010 EXAMINATIONS

1. GG 311 –Crystallography and Optical Mineralogy
2. GG 201 –Introduction to Geology
3. GG 311 –Crystallography and Optical Mineralogy
4. GG 335 -Structural Geology and Mapping Techniques
5. GG 411 –Igneous Petrology
6. GG 421 –Sedimentology
7. GG 435 –Structural Geology and Plate Tectonics
8. GG 471 –Geochemistry –Paper I
9. GG 471 –Geochemistry –Paper II

10. GG 551 –Exploration, Mining Geology and Management

11. GG 581 –Applied Geophysics

12. ME 341 – Thermodynamics

13. MI 205 –Introduction to Mine Development

14. MI 455 –Operations Research

15. MI 465 –Mineral Economics

16. MI 475 –Mine Ventilation

17. MI 535 –Coal Mining

18. MI 561 –Geotechnical Engineering

19. MI 585 –Mine Transportation

20. MM 411 –Comminution and classification

21. MM 515 –Special Topics in Mineral Processing

22. MM 525 –Mechanical Metallurgy

THE UNIVERSITY OF ZAMBIA

FIRST SEMESTER UNIVERSITY EXAMINATIONS – NOVEMBER 2009

GG311 CRYSTALLOGRAPHY AND OPTICAL MINERALOGY

PAPER II – PRACTICAL

INSTRUCTIONS: ANSWER ALL QUESTIONS.

TIME: ONE AND HALF HOURS

- Q.1 You are given Model 10. Do the following (20 marks):
- (i) Determine the elements of symmetry (i.e. diads, triads, tetrads, hexads, planes of symmetry and centre).
 - (ii) Using the characteristic elements of symmetry classify the crystal into a given crystal system and state why.
 - (iii) Sketch the crystal and indicate on it the characteristic elements of symmetry.
- Q.2 Plot a stereogram of Model 10 indicating on it the elements of symmetry and crystallographic axes. (15 marks)
- Q.1 Using the optical properties identify the mineral in the given thin section A. (15 marks)

-----END OF EXAMINATION-----

**THE UNIVERSITY OF ZAMBIA
SCHOOL OF MINES**

FIRST SEMESTER EXAMINATIONS – OCTOBER 2010

GG201 – INTRODUCTION TO GEOLOGY

PAPER II - PRACTICAL

INSTRUCTIONS:	Answer all questions. Illustrate your answers wherever possible.
TIME:	Three (3) Hours

- Q1. You are provided with mineral specimens A, B, and C. Using the following physical properties identify the minerals: colour, hardness, streak, cleavage/fracture, magnetism, feel & reaction with acid. You are expected to describe the properties. (15 marks)
- Q2. Rock specimens D, E, and F have to be identified. Use the following physical properties to identify these rocks: colour, texture (grain size), structure (foliation – schistosity, gneissosity; bedding) or massive (without structure), mineralogy, reaction with acid, crystalline or not, sorting, roundness, & versicular or amygdaloidal. State with reasons whether the rock is igneous, sedimentary or metamorphic. (15 marks)
- Q3. Using Map X on which layers A, B, C, D, E and F are shown to be exposed, do the following (scale 2.5cm to 500 m):
- (a) Determine with reason(s) whether the strata in the given map are horizontal, inclined or vertical; (3 marks)
 - (b) Draw strike lines and label them appropriately. (10 marks)
 - (c) Determine the strike, dip and dip direction assuming that the layers are of uniform dip. (6 marks)
 - (d) Draw the geological cross section along line Y-Z. (8 marks)
 - (e) Determine the true thicknesses for all the layers. (8 marks)
 - (f) Write a brief geological history of the area. (5 marks)

-----End of Exam & Good Luck-----

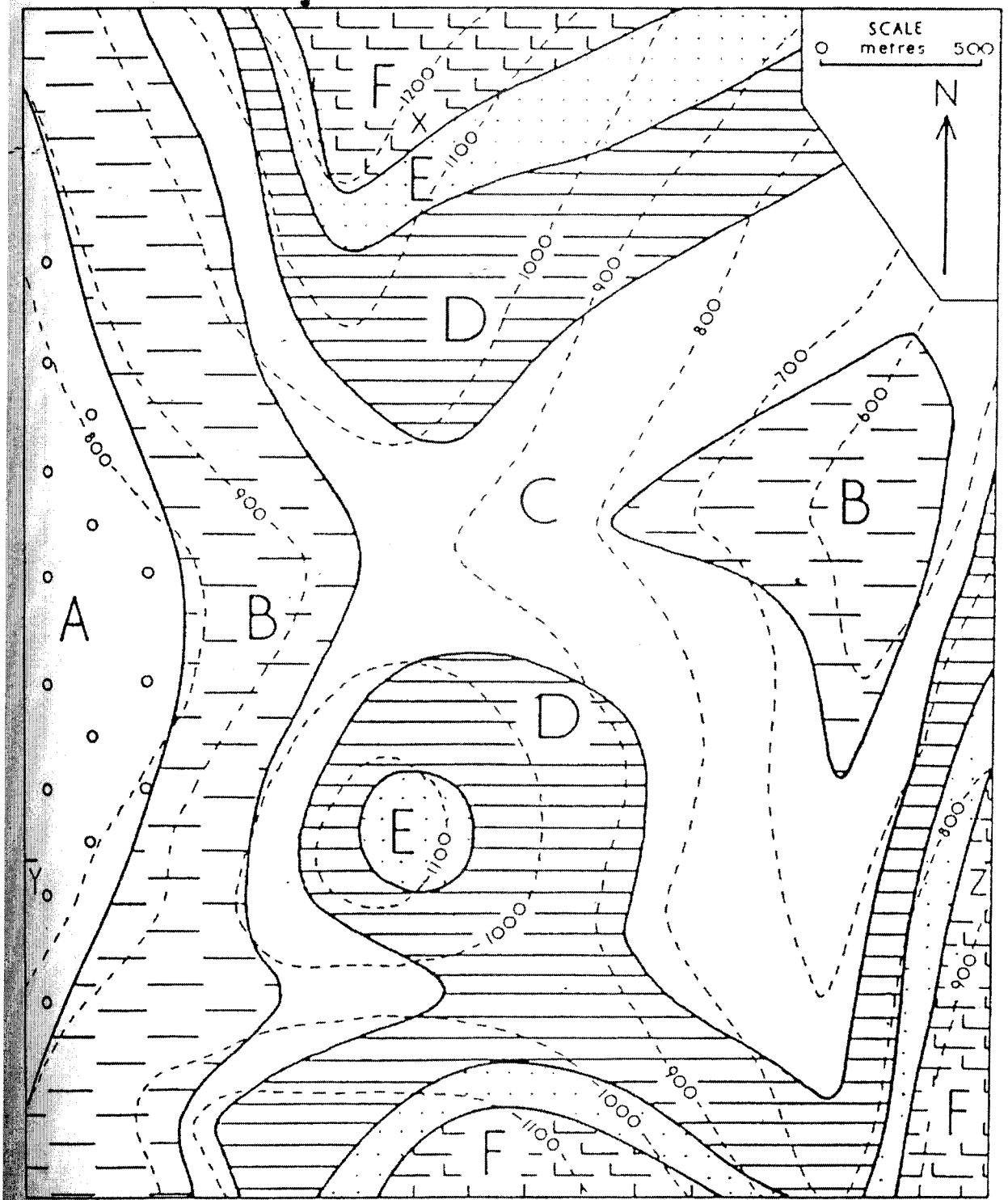

MAP X (Scale: 2.5cm to 500 m)

**THE UNIVERSITY OF ZAMBIA
SCHOOL OF MINES**

FIRST SEMESTER UNIVERSITY EXAMINATIONS – OCTOBER 2010

GG311 – CRYSTALLOGRAPHY AND OPTICAL MINERALOGY

PAPER II - PRACTICAL

INSTRUCTIONS: Answer all questions illustrating your answers wherever possible.

TIME: One and Half Hours

1. Study the mineral Y under the microscope and using optical properties identify the mineral. (15 marks)

2. Using the provided crystal model 10 and assuming that z-axis goes through centres of 2 opposite six-sided faces, x-axis through centres of 2 opposite vertical edges and y-axis through centres of 2 opposite horizontal edges and interfacial angle (or co-latitude angle) of 60° between (001) & (011) and angle between y-axis and (110) of 45° , do the following: (25 marks)
 - (a) Sketch the model and label all faces and crystallographic axes
 - (b) Identify and name the type of forms present on the crystal and faces that belong to each type
 - (c) Plot a stereogram for the crystal model ensuring that all the crystallographic axes, all the faces, and elements of symmetry (i.e. rotational axes of symmetry and planes of symmetry) are clearly labeled.
 - (d) Determine the interfacial angle between (001) and (110).

-----End of Exam-----

**THE UNIVERSITY OF ZAMBIA
SCHOOL OF MINES**

FIRST SEMESTER EXAMINATIONS – OCTOBER 2010

GG335 – STRUCTURAL GEOLOGY AND MAPPING TECHNIQUES

PAPER I - THEORY

INSTRUCTIONS: Answer any four questions. Illustrate your answers wherever possible. Questions Carry Equal marks.

TIME: Three (3) Hours

- Q1. Define any four of the following terms:
- (a) Transposition
 - (b) Microlithons
 - (c) Piercing points
 - (d) Cataclasite
 - (e) Fault line scarp
 - (f) Crenulation cleavage
- Q2. (a) Define “S-C” fabrics and state in which rock types you would expect to find them.
- (b) Make a careful sketch of S and C planes in a left-lateral shear zone. Be sure to label the planes and show where you would expect the highest strains to be found.
- Q3. (a) Describe how folds with class 2 dip isogers are produced.
- (b) Compare and contrast buckling and flexural slip.
- (c) Compare and contrast between ductile deformation and brittle deformation (discuss processes and products for each)
- Q4. (a) What are the similarities and differences among mylonites, breccia and gouge? In your answer, be sure to explain the processes by which each forms and where in the crust you would expect to find each one.
- (b) Discuss the net stratigraphic effect commonly produced by a thrust fault (use a diagram)
- Q5. (a) Discuss the difference between force, stress, and strain.
- (b) Explain the major difference between co-axial and non-co-axial strain and give examples.
- (c) Using stress-strain diagrams, show the difference in deformation response between elastic and linear viscous (Newtonian) materials.
- Q6. (a) What is compressive rock strength?
- (b) Define homogenous strain and provide an example.
- (c) What are the rheological characteristics of plastic deformation?
- (d) Define linear strain and provide examples

-----End of Exam and Good Luck!-----

THE UNIVERSITY OF ZAMBIA
SCHOOL OF MINES
UNIVERSITY EXAMINATIONS – OCTOBER 2010

GG 411 – IGNEOUS PETROLOGY

PAPER I – THEORY

INSTRUCTIONS: ANSWER ANY FIVE QUESTIONS USING SKETCHES
WHEREVER POSSIBLE; ALL QUESTIONS CARRY EQUAL
MARKS.

TIME: THREE (3) HOURS

- Q1. (a) Rocks are correlated to plate tectonics. Show how plate tectonic settings and magmatism are correlated.
- (b) Basaltic rocks can be divided into tholeiitic and alkali groups, what are the main criteria for distinguishing the two groups?
- Q2. Differentiate between the following:
- (a) Eutectic point and coetectic point in geological phase diagrams.
- (b) Shallow granitic intrusions and deep-seated granitic intrusions.
- (c) Tholeiitic basalt and alkaline basalt.
- Q3. Summarize the main characteristic features of the Skaergaard Igneous Complex.
- Q4. Show how magmatic rocks can be divided into alkaline and subalkaline.
- Q5. Define the following terms:
- (a) Ophiolite
- (b) Degree of freedom
- (c) Liquid immiscibility
- (d) Magmatic differentiation
- Q6. (a) What is the importance of Kimberlites?
- (b) Show how Kimberlites are classified.
- (c) Discuss the tectonic setting of Kimberlites.
- (d) Name three countries in Africa where Kimberlites are found
- Q7. What are the main characteristics features of GRANITE ROCKS?

-----Good Luck and End of Exam-----

THE UNIVERSITY OF ZAMBIA
UNIVERSITY EXAMINATIONS – OCTOBER 2010

GG 421 – SEDIMENTOLOGY

PAPER II – PRACTICAL

INSTRUCTIONS: Answer both questions.

TIME: Three (3) Hours

Q1. A property development company has acquired a piece of land from the City Authorities to construct a housing estate. It is a known fact that the area is underlain by a sequence of sedimentary rocks. The continuity of the various lithologies is not established since no detailed subsurface geological work has been done over the area so far. The property development company is concerned about this lack of detailed geological information as it needs to plan well on where to locate what type of structures. In essence, the company wants to know the distribution of the competent and less competent rock formations.

Your company has been engaged for geological consultancy services to undertake site investigations. You are the geologist that has been assigned the task. Your Company has in its possession logs of two bore holes, SM/1 and SM/2, which were drilled in the area many years ago. It intends to extract as much information from them as possible before moving to the next step. Bore hole SM/2 is 557m to the east of SM/1. The logs are not very good but that is all there is available.

As the initial phase of the consultancy, your Boss has instructed you to carry out the following (70 marks):

- (a) Make sedimentary logs of both cores, using the standard format available;
- (b) Interpret these cores in terms of processes of deposition and depositional (sub) environment basins, indicating how some facies are related to each other;
- (c) Correlate the two bore holes with a view of establishing possible continuities and comment, with good reasons, on whether their rocks were deposited in the same sub-basin or channel;

Log: SM/1 (Bore hole collar = 665m above sea level)

0-2m	Very fine-grained mudstone, in places with shaly partings, desiccation cracks and root traces;
2-5m	Very fine- to medium-grained sandstone, horizontal bedding and locally massive;
5-10m	Coarse-grained to pebbly sandstone, trough cross-bedding alternating with planar x-beds;
10-16m	Matrix supported conglomerates, massive with crude bedding locally horizontal bedding;
16-19m	Clast-supported conglomerates, complex bed forms with tabular sheets;
19-21m	Pebbly sandstones, trough cross-bedding;
21- 24m	Very coarse grained sandstone, trough cross-bedded to parallel laminated;
24-25m	Medium-grained sandstone, ripple cross-laminated;
25-27m	Alternating mudstone and very fine-grained sandstone;
27-28.5m	Pebbly mudstone at base that is followed by mudstone, massive, followed by thinly laminated and then massive beds

Log: SM/2 (Bore hole collar = 753m above sea level)

0-2m	Mudstone, in places with intraclasts, massive beds, desiccation cracks;
5-7m	Clast-supported conglomerates – mainly cobbles, complex bed forms with tabular sheets;
7-15m	Matrix supported conglomerates – mainly pebbles, massive with crude bedding locally horizontal bedding;
15-20m	Very fine-to medium-grained sandstone, horizontal bedding and locally massive;
20-23m	Mudstone, in places with shaly partings, thinly laminated overlain by massive beds; bioturbated with root traces;
23-24.5m	Undifferentiated metasediments

Q2. You are provided with four hand specimens marked A, B, C and D. You are required to do the following (30 marks):

- (a) Describe the texture, composition, colour and any observable structures of each specimen, and then name the rock;
- (b) Outline briefly, the depositional environment of each rock, suggesting the possible transportation mechanisms and distance from the source.

-----End of Exam and Good Luck-----

UNIVERSITY OF ZAMBIA
UNIVERSITY EXAMINATIONS – OCTOBER 2010

GG435-STRUCTURAL GEOLOGY AND PLATE TECTONICS
PAPER II - PRACTICAL

Instructions: Answer All Questions
 Time: Three (3) Hours

Q1. Below is a map that shows the geology of Spring Valley area. Answer the questions that follow:

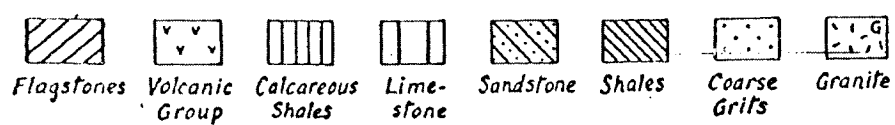
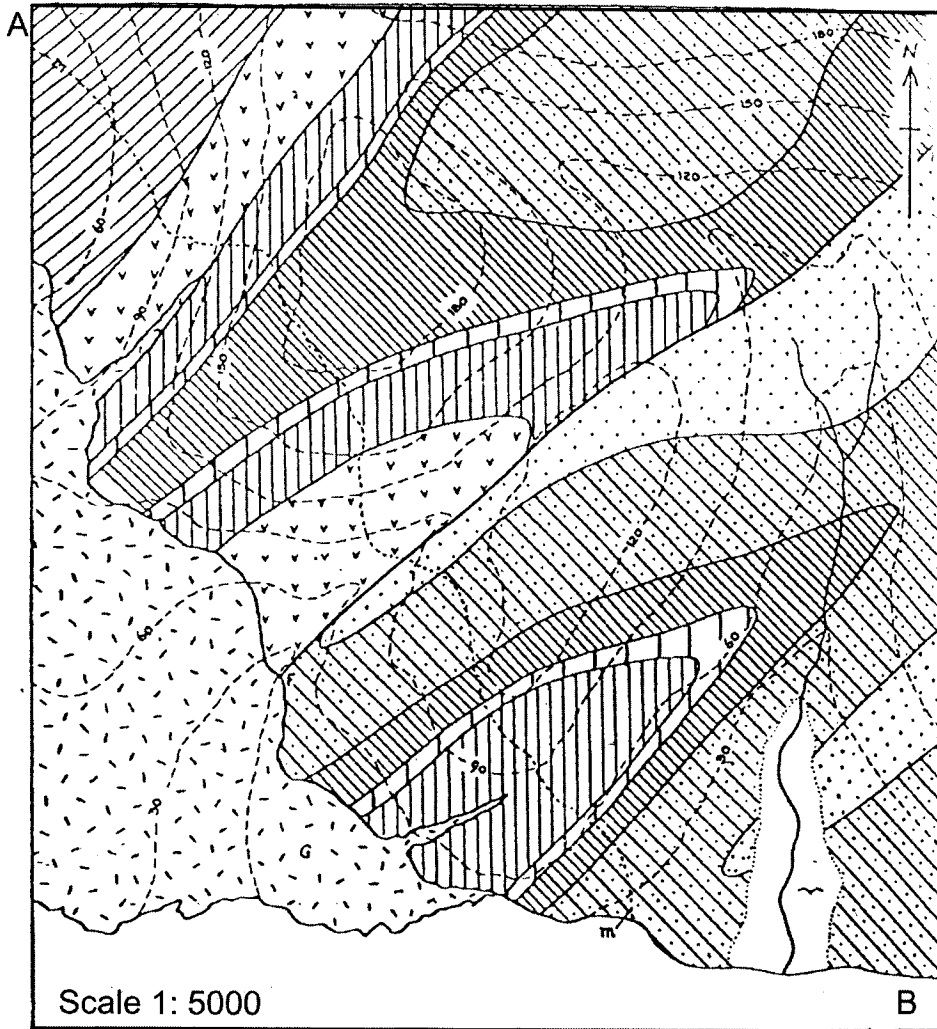

(a) Draw structure contours (strike lines) on the map and then a cross-section A-B. Use the cross-sections to write the geological history of the area. (60 marks).

Q2. A sandstone bed of possible Cambrian age in the Gwembe Valley is oriented $360^{\circ}40'W$ and possesses ripple marks oriented 33° towards 233° . What is the current direction that deposited the bed in Cambrian times? (10 Marks)

Q3. The "Mabvuto Anasila" area has been mapped by an exploration geologist. However his field note book and map were burnt in a tent in his camp site while in the field. One excel file which he had sent to the main office in Lusaka has been retrieved for a partial report and recorded the following information:

S_0 (bedding) was measured at $020^{\circ}30'E$; schistosity (S_1) was measured as $060^{\circ}60'NW^{\circ}$; flute marks were measured as 12° towards 318° . Some areas with the same geology are not folded, but are sub-cropping. The ripples possess heavy mineral sands and their orientation in the unfolded zone is required for drilling.

- (a) Find the other limb of the fold in the area. (5 marks)
- (b) What is the orientation of the fold axis in the area? (5 marks)
- (c) What was the orientation of the flute marks before the beds were folded? (5 marks)
- (d) Write the geological history of the area based on his structural data and show how the ripple marks can be obtained from the flute marks data (15 Marks)

-----End of Exam and Good Luck-----

THE UNIVERSITY OF ZAMBIA
FIRST SEMESTER UNIVERSITY EXAMINATIONS – OCTOBER 2010
GG 471 - GEOCHEMISTRY

PAPER I – THEORY

INSTRUCTIONS: Answer any five questions. Use diagrams and equations wherever necessary. All the questions carry equal marks.
TIME: Three (3) Hours

- Q1. Describe the relative abundances of the major elements in the continental crust and the major methods that have been employed to determine these abundances.
- Q2. Use the thermodynamic data given below and appropriate equations to construct an Eh-pH diagram for the system U-O-H at 1 bar pressure and 25 °C. Discuss how the addition of carbonate ions to this system may affect the mobility of uranium.

Species	ΔG_f^0 (Kcal/gfw)
UO ₂ (c)	-246.62
U ₃ O ₈ (c)	-805.35
UO ₂ ²⁺ (aq)	-227.66
H ₂ O (liq)	-56.69

- Q3. Discuss briefly the major factors that control the aqueous mobility of Al, Fe, S and Cu in the surficial environment.
- Q4. The chemical composition of sediments in three sedimentary environments is given in table 1. Use the given data to answer the following questions:

Table 1. Composition of sediments

Component	Sediment A	Sediment B	Sediment C
SiO ₂	48.90	1.15	51.03
Al ₂ O ₃	12.8	0.45	13.47
Fe ₂ O ₃	5.54	-	8.06
FeO	-	0.26	-
MgO	2.48	0.56	1.15
CaO	9.79	53.80	0.78
Na ₂ O	1.57	0.02	0.41
K ₂ O	2.52	0.05	3.16
TiO ₂	0.58	-	-
P ₂ O ₅	0.17	-	0.31
S	1.63	-	7.29
CO ₂	7.30	42.69	-
C	1.32	-	13.11
H ₂ O	6.26	0.92	3.2

- (a) Describe the mineralogical composition of the sediments and establish the prevailing Eh and pH conditions in the sediments.

(b) Discuss briefly the processes through which the minerals in the sediments have been formed.

Q5. The chemical composition of ocean water is given below. Use the supplied data and equations to determine the state of saturation of this water with respect to anhydrite.

Component	Ocean water (g/kg)
Na ⁺	10.7
K ⁺	0.39
Ca ²⁺	0.41
Mg ²⁺	1.29
Cl ⁻	19.35
SO ₄ ²⁻	2.71
HCO ₃ ⁻	0.72

$$-\log \text{ activity coefficient} = Az^2[(I^{0.5}/1+I^{0.5})-0.2I]$$

$$A = 0.5085$$

$$K_{sp} \text{ for anhydrite} = 10^{-4.5}$$

Q6. The composition of the parent rock and the soil developed on it is given below. Use the supplied data to answer the following questions.

Component	Parent rock	Soil
SiO ₂	50.4	0.7
Al ₂ O ₃	22.2	50.5
Fe ₂ O ₃	9.9	23.4
FeO	3.6	-
MgO	1.5	-
CaO	8.4	-
Na ₂ O	0.9	-
K ₂ O	1.8	-
TiO ₂	0.9	0.4
H ₂ O	0.9	25.0

- Determine the drainage and climatic conditions under which the soil has developed.
- Arrange the major elements in increasing order of mobility in this environment.
- Describe the dominant processes through which the soil has formed.

- Q7. (a) Write short notes on the classification of surficial dispersion patterns of ore components.
- (b) Describe the processes that would lead to the development of dispersion patterns of Sn and Ta in the drainage system of an area where mineralized pegmatites whose average composition is given below are exposed.

Component	Pegmatite
(%)	
SiO ₂	73.75
Al ₂ O ₃	15.47
Fe ₂ O ₃	0.64
FeO	-
MgO	0.006
CaO	0.01
Na ₂ O	0.34
K ₂ O	4.48
TiO ₂	0.001
P ₂ O ₅	0.04
(ppm)	
Rb	2816
Sn	1350
Ta	356

-----End of Exam and Good Luck!-----

THE UNIVERSITY OF ZAMBIA
FIRST SEMESTER UNIVERSITY EXAMINATIONS – OCTOBER 2010

GG 471 - GEOCHEMISTRY

PAPER II – PRACTICAL

INSTRUCTIONS: Answer all the questions. Use diagrams and equations wherever necessary.

TIME: Three (3) Hours

- Q1. Describe the analytical procedures which you would employ to determine the concentrations of heavy metals in soils contaminated by emissions from the smelter stacks. (15 marks)
- Q2. The composition of 3 samples collected from 3 different natural waters are given in table 1. Use the data in table 1 to answer the following questions. (25 marks)
- (a) Classify the waters on the basis of TDS and give suggestions on the most likely sources of these samples.
- (b) Discuss the quality of the water samples and the major factors that appear to be controlling the concentrations of the dissolved constituents.

Table 1

Constituent	Groundwater	Surface water A	Surface water B
Ca	260	3.2	411
Mg	49	0.1	1290
Na	13	1.2	10700
K	3.2	0.14	390
Silica	23	0.1	2.9
Al	12	-	.001
Fe	143	-	.034
Zn	345	0.0003	.01
Sulphate	1650	5.1	2710
Cl	3.7	1.0	19350
TDS	2500	11	35500
pH	2.5	3.5	8.2

- Q3. The data obtained in an orientation survey for nickel anomalies in stream sediments of the Munali Hills area is given in figure 1 and table 2. The host rock for the nickel mineralization is the Munali gabbro. In the search for gabbro hosted nickel deposits a reconnaissance stream sediment survey conducted in solwezi area generated the data in table 3. Use the given data to answer the following questions.
- (a) Identify the elements that are associated with nickel in figure 1 and discuss the possibility of using Fe, Mg, Co, Pt and S as path finder elements in hydrogeochemical surveys.
- (b) Discuss the processes that have led to the development of the nickel and

- copper dispersion patterns in figure 1.
- (c) Use an appropriate statistical method to establish the range of background and anomalous values in table 3.
 - (d) Discuss the potential for nickel sulfide mineralization in Solwezi area.

Table 2

S.NO.	Sample type	Fe (%)	Ni (ppm)	Cu (ppm)	Co (ppm)
1a	Rock	12.03	2068	164	147
1b	Gossan	66.36	8020	423	5
1c	Rock	11.49	1972	201	149
1	Stream sediment	52.28	506	266	296
2	"	38.17	274	152	129
4	"	32.78	192	170	119
6	"	23.13	119	140	8
7	"	12.33	43	40	30
8	"	16.86	108	42	9
9	"	10.14	38	37	41
10	"	15.54	87	102	6
11	"	9.05	33	34	45
12	"	13.89	61	74	33
14	"	28.34	85	85	63

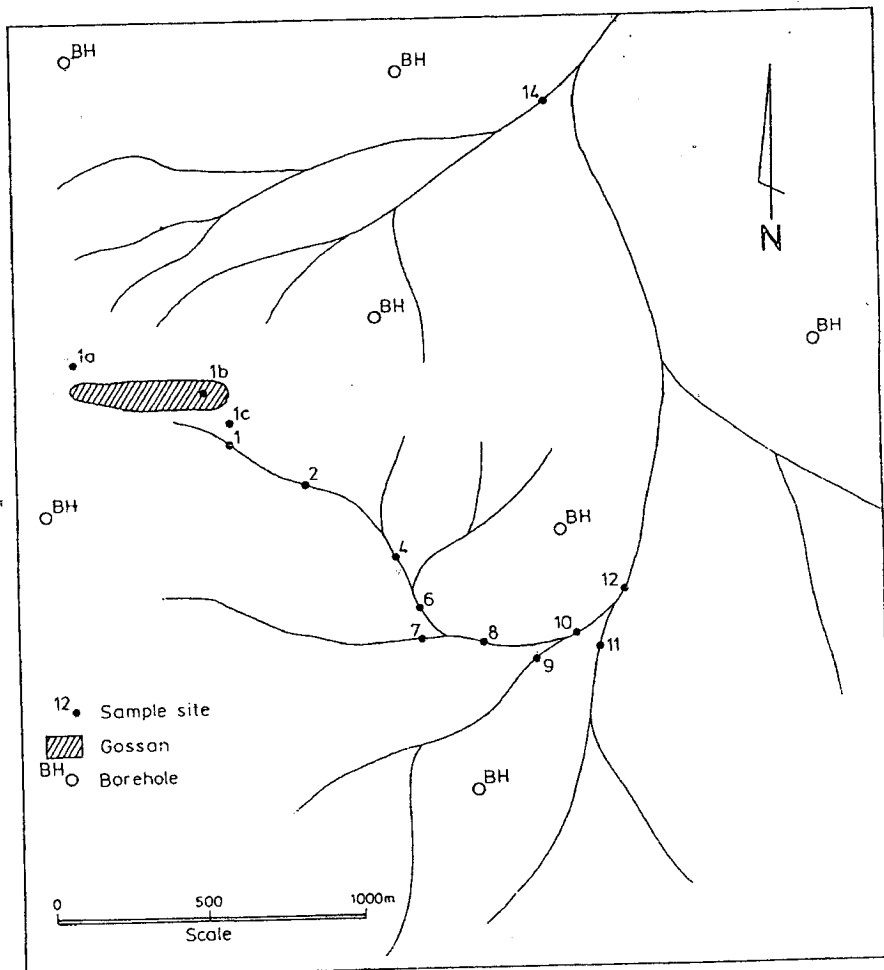

Figure 1

Table 3

Ni content (ppm)	Frequency
0	5
5	10
10	82
15	31
20	162
25	35
30	187
35	39
40	189
45	31
50	141
55	34
60	129
65	23
70	73
75	16
80	42
85	10
90	38
95	4
100	25
105	2
110	9
115	1
120	5
125	1
130	2
140	1
145	1
160	1
170	2
190	1
220	2
270	1
330	1
455	1
660	1
909	1

-----End of Exam and Good Luck-----

THE UNIVERSITY OF ZAMBIA
UNIVERSITY EXAMINATIONS – OCTOBER 2010

GG 551 - EXPLORATION, MINING GEOLOGY AND MANAGEMENT

Instructions: Answer Any Four (4) with at least one question from each section.
Answer four (4) questions. You have 5 minutes to read through the questions.

Time: Three (3) Hours

SECTION A

- Q1. (a) It is said that the life a mine does not start the day that production begins, but many years before, when a company sets out to explore for a mineral deposit. State and briefly describe the stages of an exploration project from the study phase to Bankable Feasibility Study (BFS) (5 marks).
- (b) Your Canada-based exploration manager wants you to explore the possibility of carrying out copper exploration in Central Africa. Prepare him/her some relevant notes for at least two countries in the region, stating the factors that have influenced your choice of country and area (5 marks).
- (c) Exploration strategy may be classified as either empirical or conceptual. Discuss the two approaches with regard to the following aspects:
- (i) Number of prospects that may be initially generated (2 marks)
 - (ii) The quality of the prospects (2 marks)
 - (iii) the levels of expertise required (2 marks)
 - (iv) Define the following terms:
 - a. Greenfields exploration (2 marks)
 - b. Brownfields exploration (2 marks)
 - (v) You are exploring for magmatic nickel sulphide style mineralization and you have got several ground geophysical techniques at your disposal. Your hanging wall lithologies at one of your preferred targets comprise graphitic schist, dolomites and quartzites in this order away from the suspected host gabbro.
 - a. State any one technique likely to produce appreciable contrast (2 marks)
 - b. State the technique that is likely to produce ambiguity and the likely cause/s (3 marks).
- Q2. (a) You have been approached by a businessman who wants to drill his newly acquired oxide copper prospect. He would like some professional advice on the most suitable drilling technique. With him is a list of techniques he has got from a student geologist including:
- (i) Hand Auger
 - (ii) Rotary Air Blast (RAB)
 - (iii) Reverse Circulation
 - (iv) Diamond

- Prepare a summary report for him, preferably in tabular format, detailing the suitable applications, advantages and disadvantages of each technique (10 marks).
- (b) Drillholes rarely take straight paths from collar positions. List at least 5 causes of drillhole deviation (5 marks).
- (c) You have received some assay results for your geochemical anomaly and you are suspicious that they (the results) could be a hydromorphic artifact. What step/s could you take to prove or dismiss this suspicion? (2 marks).
- (d) When carrying out soil surveys, it is critical to differentiate residual from transported overburden. For each type of overburden, give at least two (2) characteristics (5 marks).
- (e) How would you physically and chemically differentiate a true gossan from a false gossan (3 marks).

SECTION B

- Q3. (a) Define the following terms as they relate to a mining environment:
- (i) Internal dilution (1 mark)
 - (ii) External dilution (1 mark)
 - (iii) A regionalized variable (1 mark)
 - (iv) Geological continuity (1 mark)
 - (v) Value/grade continuity (1 mark)
- (b) You have been approached by a group of businessmen which has won a tender to supply nickel ore to a nearby operating mine in Zambia. They would like you to determine the tonnage and average grade of their nickel deposit (Chilengwaleza Ni project) for them to present to their client. You find historical data at the Geological Survey Department which summarizes the deposit as follows:
- 10 holes completed on the deposit in 1978. Results for a section comprising two adjacent holes (DDH001 and DDH002) available on the public domain, the rest of the results missing. The holes were 25m apart. Section lines on which the holes are located are at a distance of 50m apart. Average RL of 800m.
 - Mineralization outcrops ~25m due east of DDH001.
 - The ore body has two different types of ore: lateritic ore and semi-massive ore. The lateritic ore is allocated a specific gravity (SG) of 1.25 whereas the semi-massive ore is allocated specific gravity of 2.0
 - The ore body strikes North-South and dips at around 60° towards the west. All drilleholes inclined at -65° at collar.
 - Holes deviated at an average rate of 1° every 18m or 0.5° every 9m in the hangingwall. Negligible deviation in intervals less than 9m. More deviation observed in the hangingwall lithologies. Limited deviation within the orebody. All holes deviated upwards.
- The rest of the data regarding the deposit is presented in Table 1:

Table 1: Chilengwaleza Ni project assay data

Hole_ID	From	to	Drilled length (m)	Mineralized intersection (m)	Ni assay (%)	Geology notes
DDH001	0	27	27	-	Not assayed	Overburden
DDH001	27	31	4	4m from 27m	1.2%	Lateritic zone, base of lateritic ore zone at 31m
DDH001	31	35	4	4m from 31m	2.9%	Semi-massive ore
DDH001	35	40	5	-	not assayed	End of hole at 40m, Barren Gabbro.
DDH002	0	54	54	-	Not assayed	Overburden, hole collared down-dip of DDH001
DDH002	54	58	4	4m from 54m	1.1%	Lateritic zone, base of lateritic zone at 58m
DDH002	58	61	3	3m from 58m	3.5%	Semi-massive ore
DDH002	61	70	9	-	Not assayed	End of hole at 70m. Barren Gabbro.

Using the provided data:

- (i) Sketch a profile (not to scale) of the nickel deposit (*2 marks*)
- (ii) Calculate the respective average grades (% Ni) of the intersections at DDH001 and DDH002 (*8 marks*)
- (iii) Calculate the respective tonnages around DDH001 and DDH002 (*8 marks*)
- (iv) Present to your client the total tonnage and average grade of the section across DDH001 and DDH002 (*2 marks*).

- Q4. (a) You are a consulting geologist at Chuumbabenzu Coal prospect in Zambia's Southern Province and have been presented with the following proximate analysis results for the main seam (Table 2).

Table 2. Proximate analysis results for Chuumbabenzu Coal Prospect.

Parameter	%
Moisture	1.0
Volatiles	27.2
Fixed Carbon	50.7
Ash	21.1
Calorific Value (Air dried) B.T.U./lb	10600

- (i) Classify the coal according to the American Society for Testing and Materials (ASTM) and advise on the possible uses of this coal based on the preliminary results (*5 marks*)
- (ii) State at least three elements you would consider submitting for ultimate analysis with brief notes on the relevance of each analyte (*3 marks*)

- (b) A number of theories have been proposed to explain the origin of the Central African Copperbelt mineralization.
- (i) Describe the merits of the syndiagenetic model vs the syngenetic model (5 marks)
 - (ii) The major weakness of an epigenetic model for the Lower Roan-hosted Copperbelt mineralization (2 marks).
 - (iii) Describe the geology of the Zambian Copperbelt with regard to the metal sources, transport mechanism, precipitation mechanism and state the desired attributes of this deposit type that might be used to explore for deposits of similar style (10 marks).

SECTION C

- Q5. (a) Communication can be in different forms including written, verbal or visual, among others. Give the advantages and disadvantages of the mentioned forms of communication (15 marks)
- (b) Describe what you understand by the following managers' roles:
- (i) Planning (2 marks)
 - (ii) Organising (2 marks)
 - (iii) Co-ordinating (2 marks)
 - (iv) Commanding (2 marks)
 - (v) Controlling (2 marks)
- Q6. (a) Define a decentralized management structure and give at least three of its advantages (5 marks)
- (b) Many large organizations today prefer outsourcing labour. Define the concept of outsourcing, giving at least three advantages and two disadvantages of this approach (5 marks).
- (c) Leadership may be classified into three styles: autocratic, Laissez-faire and democratic. Briefly describe the three types (5 marks).
- (d) Define a trade union and state the employee benefits of belonging to one in a large organization (5 marks)
- (e) Define the following forms of Industrial Action
- (i) Strike (1 mark)
 - (ii) Picketing (1 mark)
 - (iii) Work to rule (1 mark)
 - (iv) Go slow (1 mark)
 - (v) Non-cooperation (1 mark)

-----End of Exam and Good Luck!-----

UNIVERSITY OF ZAMBIA
UNIVERSITY EXAMINATIONS – OCTOBER 2010

GG581 - APPLIED GEOPHYSICS GG581

Instructions:	Answer any five (5) Questions. Questions Carry Equal Marks.
Time:	Three (3) Hours

- Q1. (a) Explain, with the aid of diagrams, the propagation characteristics of Rayleigh and Love Waves
(b) Briefly explain the following terms: (20 marks)
(i) Aliasing
(ii) Dipole – Dipole Array
(iii) Huygen’s Principle
(iv) Reflection Coefficient

- Q2. (a) Prepare a Table of all Potential Geophysical Methods. In the Table list the “Potential Method”, the “Dependent Physical Property”, “One Primary Application” and “where in Zambia the primary application can be used”.
(b) Prepare a Table of all Active Geophysical Methods. In the Table list the “Active Method”, the “Dependent Physical Property”, “One Energy Source” and “One Primary Application”.

20 marks

- Q3. An oil prospect of low-relief anticlinal fold has a productive interval thickness of thirty (30) metres. The drainage area is estimated to be one thousand (1000) acres. From well logging work porosity was determined to be thirty (30) percent.

You are also given the following information:

Cementation factor, $m = 2$

Exponent, $n = 2$

Porosity, $\Phi = 30\%$ as determined above

Resistivity of formation water, $R_w = 0.01$ Ohmmetre

Resistivity of undisturbed zone, $R_t = 10$ Ohmmetres

Initial oil formation volume factor, $Bo_i = 1.5$ reservoir bbl
s t b

- (a) Determine Water Saturation, S_w
(b) Calculate the volume of Initial Oil in place, in stb.

20 marks

- Q4. Compare and contrast “Spectral Induced Polarization and Complex Resistivity” with “Frequency Domain Induced Polarization” method.

20 marks

Q5. Describe Vertical Electrical depth Sounding (VES) method, using Schlumberger Array. Explain its limitations

20 marks

- Q6. (a) Depth to bedrock at the School of Mines is suspected to have a small, gentle dip northward. Describe how you would use Seismic Refraction Method to confirm this setting.
- (b) A certain reversed refraction survey yielded the following information:

$$V_1 = 556 \text{ m/sec}$$

$$V_d = 3672 \text{ m/sec}$$

$$V_u = 4293 \text{ m/sec}$$

$$V_2 = 3958 \text{ m/sec}$$

$$T_{id} = 0.052 \text{ second}$$

$$T_{iu} = 0.056 \text{ second}$$

- (i) Calculate the critical angle of incidence
- (ii) Determine h_{id}
- (iii) Determine h_{iu}
- (iv) Determine angle of dip, α
- (v) Calculate Z_{id}
- (vi) Calculate Z_{iu}

20 marks

Q7. Explain, with the aid of diagrams wherever possible, the following terms as applied to Seismic reflection survey for oil:

- (a) Ground roll
- (b) Normal Move out (NMO)
- (c) Geophone
- (d) Vibroseis sweep correlation
- (e) Snell's Laws

20 marks

-----End of Exam and Good Luck-----



UNIVERSITY OF ZAMBIA
SCHOOL OF ENGINEERING
DEPARTMENT OF MECHANICAL ENGINEERING

2010 ACADEMIC YEAR FIRST SEMESTER FINAL EXAMINATIONS

ME 341: THERMODYNAMICS

TIME ALLOWED: THREE (3) HOURS

CLOSED BOOK

INSTRUCTIONS

1. Answer a **TOTAL OF FIVE (5)** questions.
 2. Answer:
TWO (2) Questions from Section A.
THREE (3) Questions from Section B.
 3. If any of **Questions 3, 5 and 7** is / are attempted, it / they should be tied together and submitted as a **separate booklet**.
 4. If any of **Questions 1, 2, 4 and 6**, is / are attempted, it / they should be tied together and submitted as a **separate booklet**.
 5. ALL Questions carry 20 Marks
 6. **THERMODYNAMIC STEAM TABLES ARE ALLOWED.**
 7. Draw neat sketches and graphs where necessary and clearly state any assumptions made.
-
-

SECTION A: Answer Any Two Questions from this Section

Question One

- (a) Briefly explain the following:
- Saturation Temperature.
 - Saturation Pressure.
 - Relationship between the saturation temperature and pressure using a sketch graph.
- (b) Derive the expression for determining the dryness fraction for the *Combined Separating and Throttling Calorimeter*.
- (c) The dryness fraction of steam flowing through a steam main at a pressure of 800kN/m^2 is to be determined using a combined separating and throttling calorimeter. If the pressure, temperature and enthalpy of the steam *after* throttling are found to be 1.013MN/m^2 , 116°C , and 2709kJ/kg respectively, and the volume of the steam condensed *after* throttling is found to be 2litres, while the water collected in the separator is 180ml, estimate the dryness fraction of the steam in the main.

[5+7+8 =20 Marks]

Question Two

- (a) Explain with relevant sketches, the working principle of the following:
- Reheating Steam Plant.
 - Regenerative Steam Plant.
 - Closed Feed Water Pre-heater.
 - Open Feed Water Pre-heater.
- (b) The University of Zambia Student Centre wishes to expand its facility to operate a small restaurant to provide lunch on week days in order to increase its revenue. The two options that are readily available for cooking are natural gas burners and electric stoves. The data sheet from the suppliers indicates that the efficiencies for the gas burners and electric stoves are 38% and 73% respectively and the rating of an electric stove is 2kW. The unit cost of electricity and natural gas are found to be K396/kWh and K 2,640/therm respectively ($1\text{ therm} = 105,000\text{kJ}$). You have been approached for advice on choosing a cost effective option by providing the following information:
- Energy consumption in kW and unit cost of energy per kWh for the electric stove.
 - Energy consumption in kW and unit cost of energy per kWh for the gas unit.
 - Your final comment.

[12+8 = 20 Marks]

Question Three

What are the pre-requisites required to transform non-reacting systems of an ideal cycle to actual combustion systems?

[20 Marks]

SECTION B: Answer Any Three Questions from this Section

Question Four

- (a) Define the following:
- Charles Law
 - Joule's Law
- (b) Air is contained in a long vertical cylinder of internal diameter 600mm, under a piston of mass 66kg at a pressure and volume of 1.45MN/m^2 and 0.13m^3 respectively. The top of the cylinder is open to the atmosphere which has a pressure of 0.101MN/m^2 . The piston is suddenly released to move upwards and the air expands to a pressure of 0.4MN/m^2 in the process. If the expansion is assumed to be frictionless and follows the law $PV^{1.36} = C$, determine:
- The distance in meters through which the piston is lifted.
 - The piston velocity at your calculated distance of lift.

[4+16 = 20 Marks]

Question Five

The pressure, volume and temperature at the beginning of compression of a constant volume cycle are 105kN/m^2 , 0.005m^3 and 20°C respectively. The maximum pressure of the cycle is 5MN/m^2 , while the volume ratio of the cycle is 10:1. *Make a sketch* of the cycle and determine:

- The pressure, volume and temperature at each of the cycle process state points.
Tabulate your results.
- The thermal efficiency.
- The theoretical output in kW if the cycle repeats 3000 times per minute
- The mean effective pressure.
- The Carnot efficiency within the cycle temperature limits.

(Take $C_p = 1.006\text{kJ/kgK}$; $C_v = 0.716\text{kJ/kgK}$; $R = 0.287\text{kJ/kgK}$)

[20 Marks]

Question Six

- Distinguish between a "Refrigerator" and a "Heat Pump". Give appropriate diagrams to illustrate your answer.
- A Freon – 12 compression refrigeration system of refrigeration capacity 7 Tons, has a condensing temperature of 50°C and an evaporating temperature of 0°C . The liquid leaving the condenser is saturated liquid and the compression is isentropic. The mass flow rate is 3.5 times the refrigeration capacity in tonnes, divided by the heat absorbed in the evaporator. Given that the enthalpy at the end of isentropic compression is 210kJ/kg , determine:
 - The mass flow rate of the refrigerant.
 - Power required for running the compressor.
 - The heat rejected in the plant.
 - The COP of the system.
- Comment on the *properties* of a good refrigerant and state the *types* that you would consider for large and small applications.

Question Seven

Propane enters the combustion chamber of a boiler and reacts with air. The heat released from the combustion produces steam in a jacket and the steam is led to expand on a turbine to produce electricity. After performing useful work, the steam is condensed and the water formed is led back to the boiler.

- (a) Name and draw the PV diagram of the ideal cycle involved in this operation.
- (b) Determine the percentage theoretical air used in the operation of this boiler if gas analysis reveals that the products of combustion include:

CO ₂	11.5%
O ₂	2.7%
CO	0.7%
N ₂	85.1%

[20 Marks]

**End of ME 341 – Thermodynamics Semester I Final Examination
November, 2010.**

**Prepared By:
Prof. F.D. Yamba and Mr. S.S. Viridy**

When net value is = \$2.5 grade is 0.55%

When net value is = -0.30 grade is 0.35%

(10 Marks)

QUESTION THREE

- a) What are the three main components of drilling equipment (6 Marks)
- b) Discuss two main theories of mechanical breakage and why most machines are indentors (8 Marks)
- c) Discuss the main types of bits, their advantages and disadvantages (6 Marks)

QUESTION FOUR

- a) Differentiate between low and high explosives (4 Marks)
- b) Using detonation theory explain why explosives are so efficient in breaking (6 Marks)
- c) Discuss the main classes of mining explosives (5 Marks)
- d) From safety fuse to current remotely controller detonation explain the major improvements in detonators (5 Marks)

QUESTION FIVE

- a) Ground control is dependent on understanding how rock/soil material behaves insitu and when excavated. Explain (5 Marks)
- b) What rock factors should be considered in designing a support system (5 Marks)
- c) (i) Discuss roof bolts as a supporting method (4 Marks)
(ii) Tuber as a supporting method (3 Marks)
(iii) Steel as a supporting method (3 Marks)

QUESTION SIX

- a) Discuss the major consideration in classifying mining methods (8 Marks)
- b) Discuss when caving methods are best used (6 Marks)
- c) Discuss the main characteristics of materials used as fill in room and pillar mining methods (6 Marks)

END OF EXAMINATION

THE UNIVERSITY OF ZAMBIA
FIRST SEMESTER UNIVERSITY EXAMINATIONS

OCTOBER 2010

MI 455: OPERATIONS RESEARCH

TIME : THREE [3] HOURS FULL MARKS : 100
INSTRUCTIONS : ANSWER QUESTION 1 AND ANY OTHER 3

QUESTION 1

- a) Clearly define the following terms as they are applied in linear programming
- i) Entering nonbasic variable **[1 Mark]**
 - ii) Surplus variable **[1 Mark]**
 - iii) Artificial variable **[1 Mark]**
 - iv) Optimal "Relaxed" solution as used in Total Integer Programming **[1 Mark]**
 - v) Branch and bound diagram **[1 Mark]**
- b) Solve the following linear programming model using the simplex method

$$Z = 20X_1 + 10X_2$$

$$X_1 + X_2 = 150$$

$$-X_1 \geq -40$$

$$X_2 \geq 20$$

$$X_1, X_2 \geq 0$$

[25 Marks]

[Total: 25 Marks]

QUESTION 2

- a) A mine developer must decide which recreation facilities to construct in its community. Four new recreation facilities have been proposed: a swimming pool, a tennis centre, an athletic field and a gymnasium. The mine wants to create facilities that will maximise the expected daily usage by residents of the community subject to land and cost limitations. Expected daily usage, cost and land requirements for each facility are shown in **Table 2**.

Table 2: Daily usage, cost and land requirements for each facility

Recreation facility	Expected usage (people/day)	Cost (\$)	Land requirements (acres)
Swimming pool, X_1	300	35,000	4
Tennis Centre, X_2	90	10,000	2
Athletic field, X_3	400	25,000	7
Gymnasium, X_4	150	90,000	3

The mine developer has a \$120,000 construction budget and 12 acres of land. Because the land for the swimming pool and tennis centre are in the same area of the country,

however, only one of these two facilities can be constructed. The mine wants to know which of the recreation facilities to construct in order to maximise the expected daily usage and you have been requested as a newly employed engineer to assist management.

- i) Construct the linear programming model for solving this problem using 0 - 1 integer programming [5 Marks]
 - ii) Using implicit enumeration, provide a complete enumeration (list of all possible solution sets) for this model [10 Marks]
 - iii) Select the optimal solution from the solution set and determine the maximum expected usage (Z value) of the facilities. [5 Marks]
- b) Clearly describe the following integer solution terminologies
- i) A total integer model [1 Marks]
 - ii) A 0 - 1 integer model [1 Marks]
 - iii) A Mixed integer model [1 Marks]
 - iv) Implicit enumeration [1 Marks]
 - v) Partitioning feasible solution [1 Marks]

[Total: 25 Marks]

QUESTION 3

Copper is produced from four mines every year as shown in Table 1.

Table 3.1: Mines producing copper

	Mines	Capacity (000'000 tonnes)
1	Luanshya	90
2	Chibuluma	50
3	Lumwana	80
4	Chambishi	60

These mines supply the following quantities of copper to manufacturing companies in three industrial cities as shown in Table 2.

Table 3.2: Manufacturing companies receiving copper shipment

	Cities	Capacity (000'000 tonnes)
A	New Delhi	120
B	Berlin	100
C	New York	110

The rail and sea shipment costs per tonne of copper are shown in Table 3. Because of railroad construction, shipments are presently prohibited from Luanshya to New Delhi.

Table 3.3: Rail and sea transportation costs (US\$'000)

FROM	TO		
	1	2	3
A	7	10	5
B	12	9	4
C	7	3	11
D	9	5	7

- a) Formulate this problem as a linear programming model. [5 Marks]
- b) Set up the transportation tableau for this problem and determine the initial solution using minimum cost method and compute the total cost. [5 Marks]
- c) Solve the model using Stepping Stone Method [10 Marks]
- d) Are there multiple optimal solutions? If so, identify them. [5 Marks]

[Total: 25 Marks]

QUESTION 4

- a) Lumwana Mine has embarked on a project to expand the current open pit mine and preliminary studies show that there will be nine (9) major activities as shown in Table 4.
- i) Construct the CPM network described by the following set of activities
 - ii) Compute the length of each path in the network
 - iii) Indicate the critical path

Table 4(a): Activity time estimates for Lumwana Mine expansion project

Activity	Time (Years)
1→2	4
1→3	7
2→4	8
2→5	3
3→5	9
4→5	5
4→6	2
5→6	6
3→6	5

[10 Marks]

- b) Given the following PERT activity time estimates, determine the expected time and variance for each activity, and indicate the critical path.

Table 4(b): PERT activity time estimates

Activity	Time Estimates (weeks)		
	a	m	b
1→2	6	10	15
1→3	2	7	16
1→4	4	8	11
2→3	3	10	15
2→5	7	9	20
2→6	4	12	15
3→6	3	6	9
4→6	5	9	16
5→7	3	20	35
4→7	4	12	16
6→7	2	9	14

- i) Construct the PERT network described by the following set of activities
- ii) Compute the expected time and variance for each activity
- iii) Indicate the critical path
- iv) Determine the probability that the project will be completed in less than 30 days

[15 Marks]

[Total: 20 Marks]

QUESTION 5

An inventory system has the following annual ordering cost of US\$200 per order, an annual unit carrying cost of US\$0.75, and an annual demand of 5000 units (assuming a 365-day year). Compute the following:

- i) Economic order quantity (Analytically and graphically) [5 Marks]
- ii) Minimum total annual inventory cost (Analytically and graphically) [5 Marks]
- iii) Optimum number of order per year [5 Marks]
- iv) Optimum time between orders [5 Marks]
- v) Why is it important to hold inventory for mining companies [5 Marks]

[Total: 25 Marks]

UNIVERSITY EXAMINATIONS

2010 SEMESTER 1 FINAL EXAMINATIONS

MI 465 MINERAL ECONOMICS

TIME: 3 HOURS

FULL MARKS: 100

INSTRUCTIONS: ANSWER ONLY FIVE QUESTIONS

1. What factors affect the supply of mineral resources in:
 - (i) The short term [10 marks]
 - (ii) The the long term? [20 points]
2. Market structures can be identified as perfect competition, monopolistic competition, oligopoly and monopoly types respectively. Give a brief description of factors that characterize each of these market structures. [20 points]
3. If the marginal revenue function of the firm is given by $MR = 100,000 - 20n$, where n is the total amount of all types of dynamite produced in units. Estimates of next year's cost has yielded the following total cost relationship:

$$TC = 0.2n^2 + 10,000,000$$

What volumes of production would have the following characteristics:

- a) Break- even point [8 points]
 - b) Maximum profit [8 points]
 - c) Minimum average cost [4 points]
4. Suppose that the demand function for commodity X is given by the equation:
$$Q_x = 60 - 1.5P_x^2 + 3P_y + 0.04I$$
 - (i) Determine the price elasticity of demand for X when $P_x = \$10$, $P_y = \$20$, and $I = \$5,000$. [10 marks]
 - (ii) What do you understand by the term "cross elasticity of demand"? Explain what happens when its magnitude assume certain values. [10 points]
 5. Discuss the major goals of macroeconomics policy and what instruments can be used to achieve these goals. [20 points]

6. What do you understand by the term “the principle of diminishing returns”? Discuss reasons why in the long-run as the scale of operations increase, diseconomies of scale may set in.

[20 points]

End of Examination

THE UNIVERSITY OF ZAMBIA
FIRST SEMESTER UNIVERSITY EXAMINATIONS

OCTOBER 2010

MI 475: MINE VENTILATION

TIME : THREE [3] HOURS

FULL MARKS : 100

INSTRUCTIONS: ANSWER ANY FIVE QUESTIONS. QUESTION ONE IS COMPULSORY.

GRAPH IS PROVIDED

Question 1

CB and later adit ED. Adit AB connects to the shaft AB, as shown in figure 1. It is decided to drive a lower level DE and deepen the shaft BD. Adits are 1.5 x 2.0 m and the shaft 1.8 x 1.8m. The friction factor for all airways is 0.01 kg/m³. If the fan is installed to exhaust 30 m³ at the collar of shaft A, determine the quantity that will flow on each level and the mine heads. Solve algebraically or graphically.

[20 Marks]

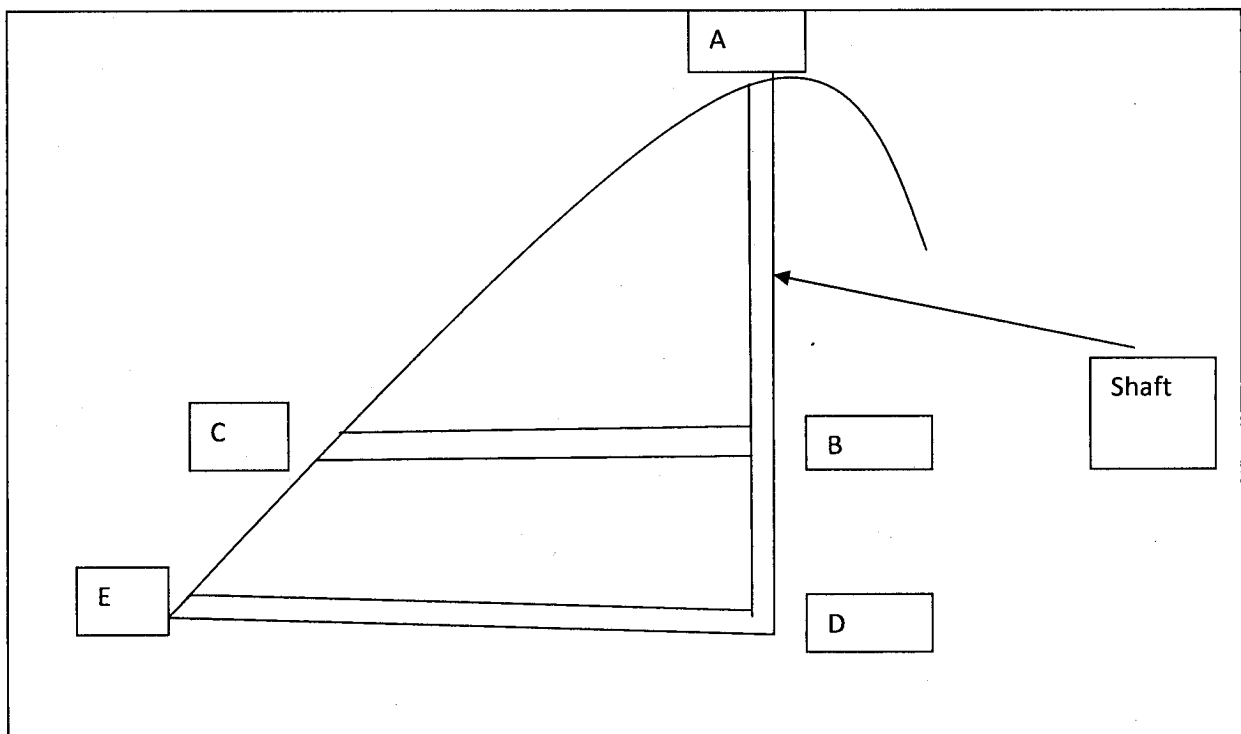

Fig. 1. Ore-body opened up by adits and shaft

Question 2

b) Determine the speed at which a 1.8m diameter fan should operate to deliver $42 \text{ m}^3/\text{s}$ at 498 Pa and density $1.36 \text{ kg}/\text{m}^3$. The fan performance for characteristic curve for a similar fan of 1.20 diameter operating at 1500 rpm and $1.20 \text{ kg}/\text{m}^3$ is given in table 1.

Fan Head, H (Pa)	Fan Quantity, Q (m^3)
1000	0
800	10
600	20
250	30

Using fan laws, plot fan characteristics curve for 1.8 m operating at 1000 rpm b.) Find speed necessary for the 1.8 fan to deliver $42 \text{ m}^3/\text{s}$ at 500 pa **[20 Marks]**

Question 3

a) Given mine schematic diagram in figure 2, calculate the natural ventilation pressure (NVP) of the system. **[10 Marks]**

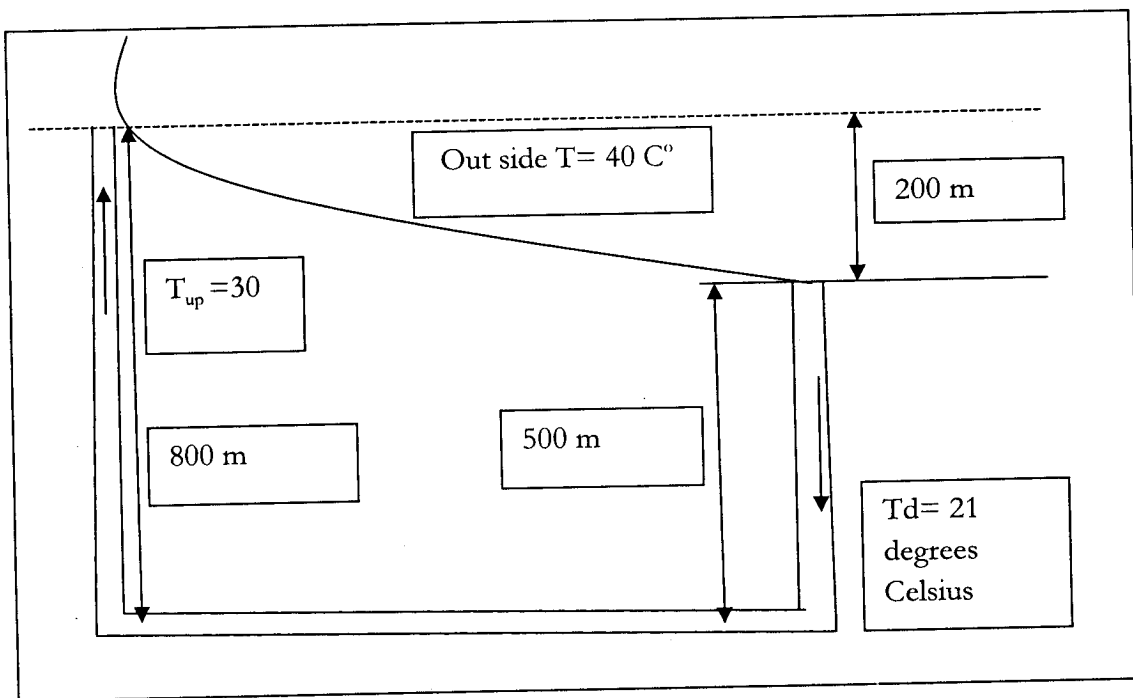

b) With the help of clear diagrams briefly explain basic mine refrigeration cycle and what can be done to the cycle to improve it. **[10 Marks]**

Question 4

- a) What is the estimated time required for the build up in an underground repair workshop of an average acetone concentration to 750 ppm, given the following standard conditions?

$C_1 = 0$ ppm, Initial concentration. Start of shift
 $C_2 = 750$ ppm - final concentration)
 $V_r = 130 \text{ m}^3$, volume of underground repair work shop
 $Q = 2.5 \text{ m}^3/\text{s}$ dilution volume flow rate

[10 Marks]

- b) With the help of clear diagrams, explain briefly various methods of cleaning contaminated air in the mine. [10 Marks]

Question 5.

Derive equations for estimating

- a) Pressure drop for a fluid under laminar flow, flowing in a smooth cylindrical pipe of uniform cross section area [15 Marks]
 b) Heat pick up in mine road ways [5 Marks]

Question 6

A two mesh network is shown diagrammatically in figure 2. A differential pressure of 2500 Pa is across the circuit and a natural ventilating pressure (NVP) of 500 Pa is applied acts in the direction of air flow with mesh 1. A regulator R_6 , is constructed in the right most branch in order to limit the airflow in that branch to $20 \text{ m}^3/\text{s}$. Given the resistance of all airways, find the distribution of air flow and the resistance of the regulator. [20 Marks]

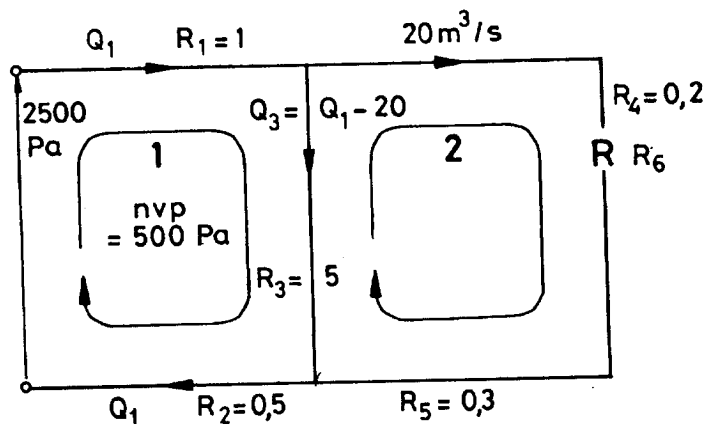

Fig. 3. Two -mesh ventilation circuit

-----END OF EXAMINATION-----

THE UNIVERSITY OF ZAMBIA
FIRST SEMESTER FINAL EXAMINATIONS

OCTOBER 2010

MI 535: COAL MINING

TIME : THREE [3] HOURS

FULL MARKS : 100

INSTRUCTIONS:

- a) ANSWER QUESTION 1 AND ANY OTHER 5**
 - b) QUESTIONS SHOULD BE ANSWERED IN THE ORDER THEY APPEAR**
 - c) NEATLY DRAWN FIGURES IS A REQUIREMENT FOR THIS EXAMINATION**
-

QUESTION 1

- a) What is a FAULT and DYKE? How the normal and reverse faults were originated? [5Marks]**
- b) Explain how the THROW and SHIFT in the case of a reverse fault can be estimated? [5Marks]**
- c) The Run- of -coal (ROM) generally contains a number of impurities due to which coal cannot be used unless these are removed. Explain with the help of diagram the method used for this purpose. [10Marks]**

QUESTION 2

- a) A coal deposit 5.0 m thick, lying at a depth of 300 m has been planned to mine using board and pillar mining. Explain, step by step, the process of development, depillaring, decision on the size of a panel, equipment for cutting the coal and transporting it on the surface keeping in mind the statutory requirements where ever necessary. [10Marks]**
- b) In a coal panel , 300 by 300 m, having 12 pillars , at a depth of 300 m to be mined . If the safety factor of the pillar to be maintained equal to 1.2, find the size of the pillar. Given the strength of the pillar equal to 10 M Pa and the unit weight of the over lying rock is 25 kN/m³. [10Marks]**

QUESTION 3

- a) A coal deposit has been decided to ~~walk~~ extract using a long wall retreat method. DESIGN a retreat face to produce two million tones of coal per year. Given, no of production shift available per day is two of 8 hours duration (but the actual production hours is only 70 % in a shift. The coal deposit is at 700 m below the earth surface and the specific gravity of coal is 1.7. Name the equipment you will need, with their location on the face , and also the system to transport the coal from face to the surface. [10Marks]**
- b) Calculate the expected % convergence in a long wall road way if the depth of coal deposits is at the depth of 600 m , the thickness of seam to be extracted is 3.0 m . Take the value of Pack Index= 2 and Floor Index =06. [6Marks]**

QUESTION 4

- a) A coal seam having a thickness of 12 m, at a depth of 600 m to be mined. Describe a suitable method to mine this deposit [10Marks]
- b) What are the different methods suggested to calculate the size of a SHAFT PILLAR? Use a method suggested by Mining Engineers for a shaft 500 m deep, having diameter equal to 6.0 m and the thickness of the coal seam extracted is 6.0 m. [6Marks]

QUESTION 5

- a) A coal seam having a dip of 23° , 5.0 m in thickness, at a depth of 250 m, has to be extracted. Describe an appropriate method keeping in mind that at least 70 % coal be extracted. [10Marks]
- b) What is a DOUBLE UNIT FACE? show by means of a diagram and write its advantages over the Single Unit Face [6Marks]
- 6 (c) What are main parameters used in the design of a coal pillar in case of room and pillar mining? How can you achieve a particular safety factor for this method? [10Marks]
- (d) Given: Pillar width = 1.5, room width = 4.2, pillar height = 3.0 m, Depth of deposit below the surface = 300m, Unit weight of overlying rock = 25 kN/m^3 , Uniaxial compressive strength = 150 Mpa. Calculate the safety factor of the pillar and comment on the stability of the same [6 Marks]

QUESTION 7

- a) According to the Coal Mining Regulations certain statutory requirements to be followed against the dangers from WATER INUNDATION, COAL and SILICA DUST, METHANE GAS, and FIRE. Write the requirements of these statutes. [10Marks]
- b) What is meant by ADEQUATE ventilation? What dangers this likely to cause if this is not maintained. [10Marks]

QUESTION 8

- a) What are the general considerations for the adoption for room and pillar and longwall method of mining? [10Marks]
- b) Why there is a variation in the thickness of the coal strata and its rank? Explain. [6 Marks]

END OF EXAMINATION

THE UNIVERSITY OF ZAMBIA
FIRST SEMESTER UNIVERSITY EXAMINATIONS
OCTOBER 2010

MI 561: GEOTECHNICAL ENGINEERING

TIME : THREE [3] HOURS FULL MARKS : 100

INSTRUCTIONS: ANSWER ALL QUESTIONS

QUESTION ONE

Large caverns mined underground are used for a variety of purposes in civil engineering. These include caverns housing turbines, electrical generators and transformers in hydroelectric projects, caverns for storing liquid or gaseous fuels, underground warehouse and underground sports facilities. Because of the high capital costs and the risks associated with public access to these facilities, care has to be taken in the design of the caverns to ensure that potential risks are kept to an absolute minimum while, at the same time providing cost effective and practical engineering solutions.

Discuss the characteristics of large caverns in jointed rock under the following headings

- a) Typical Problems
- b) Critical Parameters
- c) Stability Analysis methods
- d) Design acceptability criteria

[20 marks]

QUESTION TWO

Foundations on rock slopes act as footings and transmit various service loads depending on service structures that they serve be it residential accommodation, bridge footings or wall footings. Discuss the following as related to foundations on rock slopes:

- a) Typical problems
- b) Critical parameters
- c) Analysis methods
- d) Acceptability criteria

[20 marks]

QUESTION THREE

A typical open pit mine may only suffer two or three major slope failures during its operating life. This aside, identify the 2 distinct stages followed in the approach to the planning of a slope stability programme, identifying critical situations as they occur and remedial measures that may be undertaken. [10 marks]

QUESTION FOUR

A 40m high slope with a face angle of 60° is found to have a bedding plane running through it at a dip of 30° (See Figure below). A tension crack occurs 10m behind the crest of the slope and from an accurately drawn cross section of the slope, the tension crack is found to have a depth of 16m. The unit weight of the rock is $\gamma = 25.23\text{KN/m}^3$, that of the water is $\gamma_w = 9.81\text{KN/m}^3$

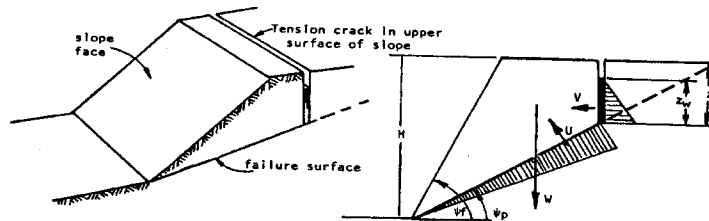

Assuming that the cohesive strength of the bedding plane is $C=47.88\text{KN/m}^2$ and the friction angle $\Phi = 30^\circ$, find the influence of water depth Z_w upon the factor of safety of the slope.

Make general comments on your findings.

Note: Use the Charts attached to end of Examination paper for Question Four [40 marks]

QUESTION FIVE

A vertical cut is expected to be made in a closely jointed and completely dry rock mass as shown in figure below.

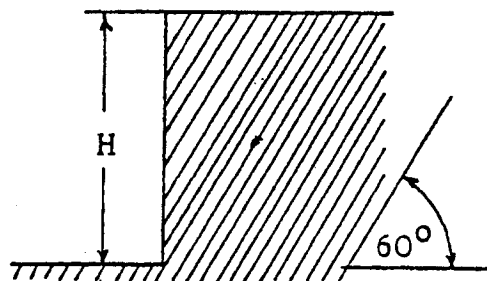

The joints strike parallel to that of the vertical cut.

Sliding would occur on the joint surfaces when:

$$\tau = 30 + 0.38\sigma$$

Where τ = Shear Stress along the dip and σ is the stress normal to the dip plane.

The mass density of rock is 2700 Kg/m^3 .

Considering a unit length of the cut:

a) Determine the factor of safety of the rock structure when the height was 6m.

b) Calculate the height at which failure would take place.

[10 marks]

END OF EXAMINATION

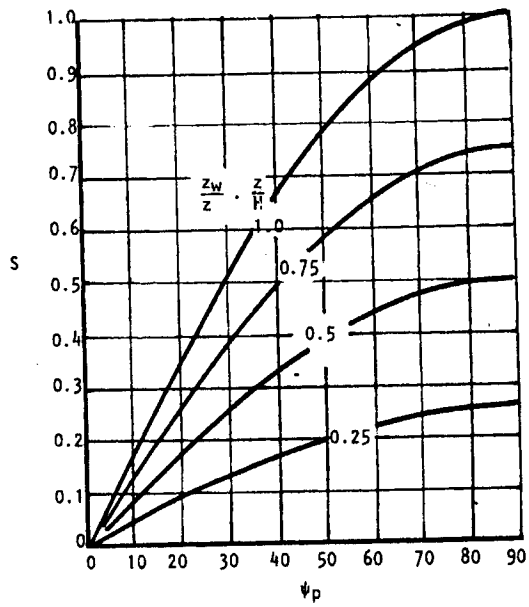
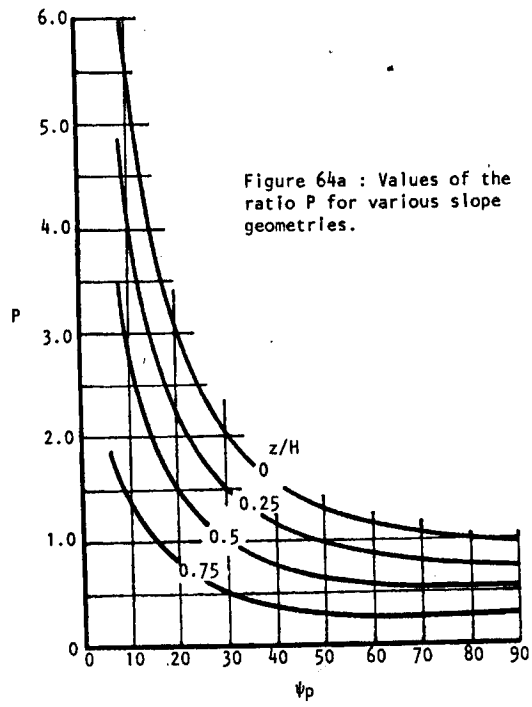
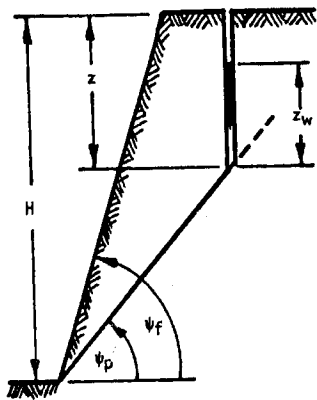

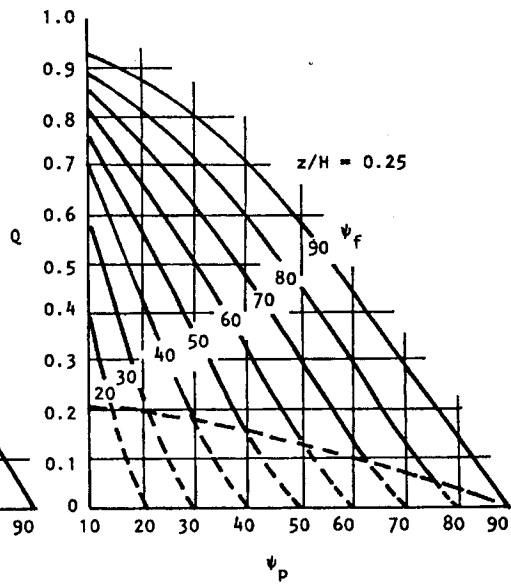
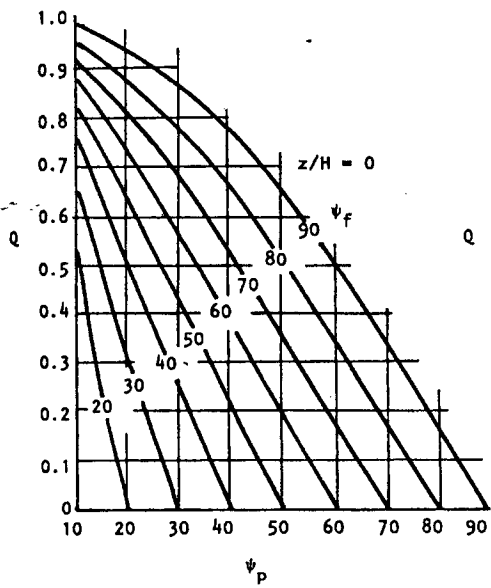

Note:
Dashed lines refer to tension crack
in slope face.

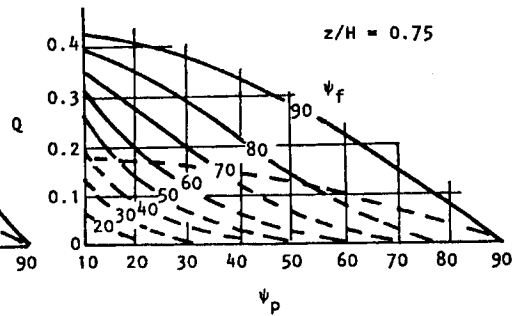
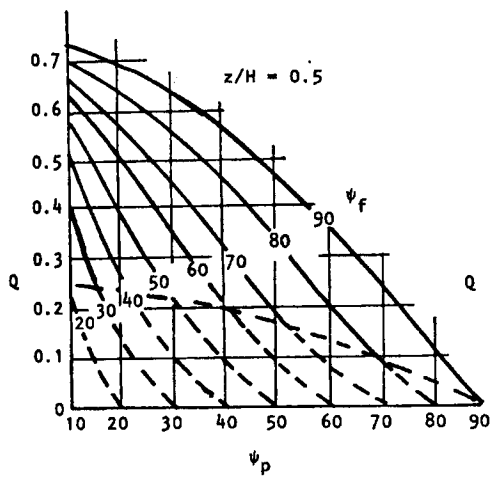

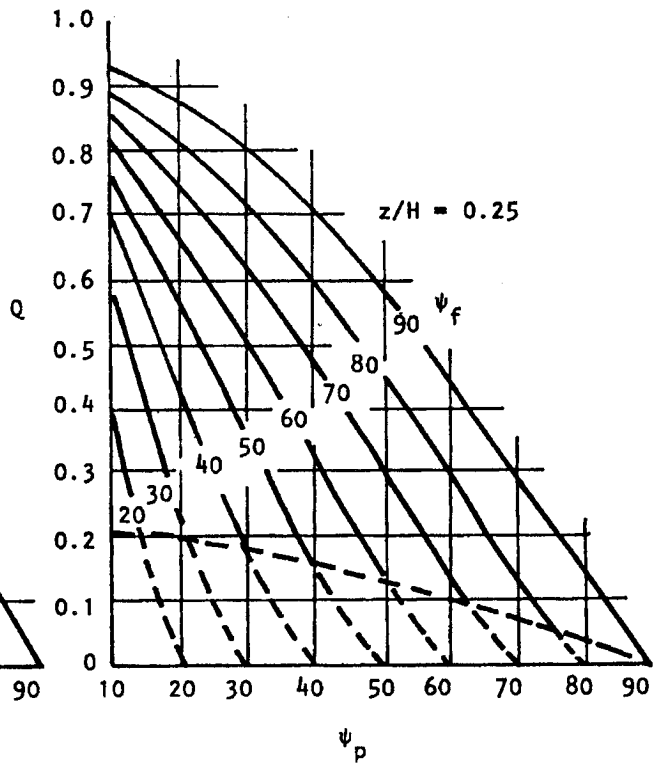
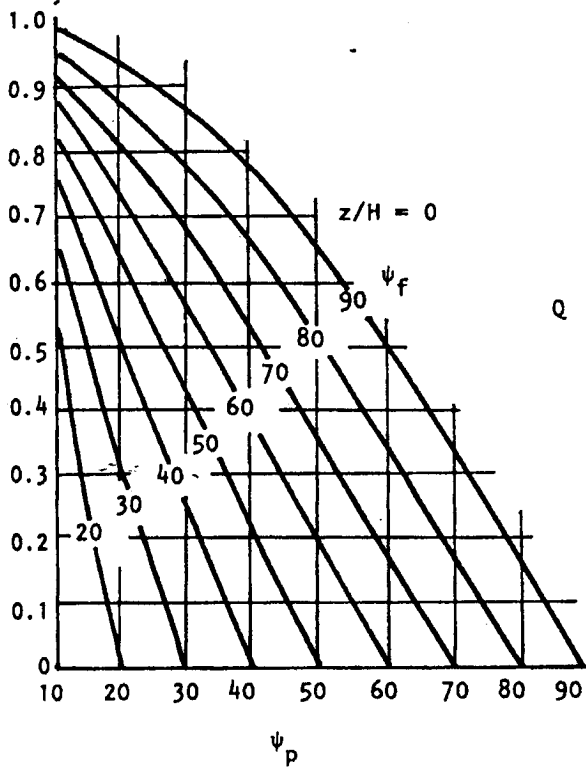

Note:
Dashed lines refer to tension crack
in slope face.

Note:
Dashed lines refer to tension crack
in slope face.

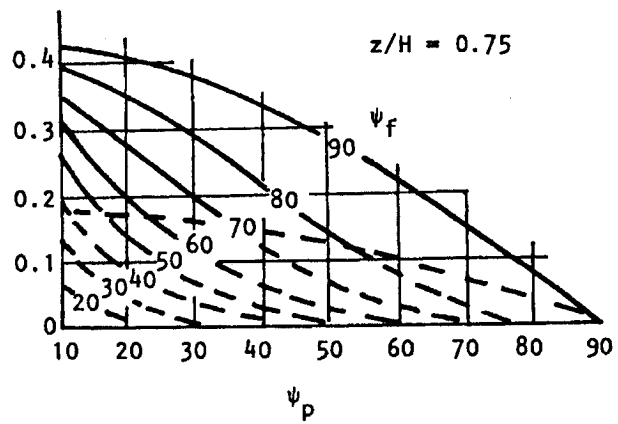
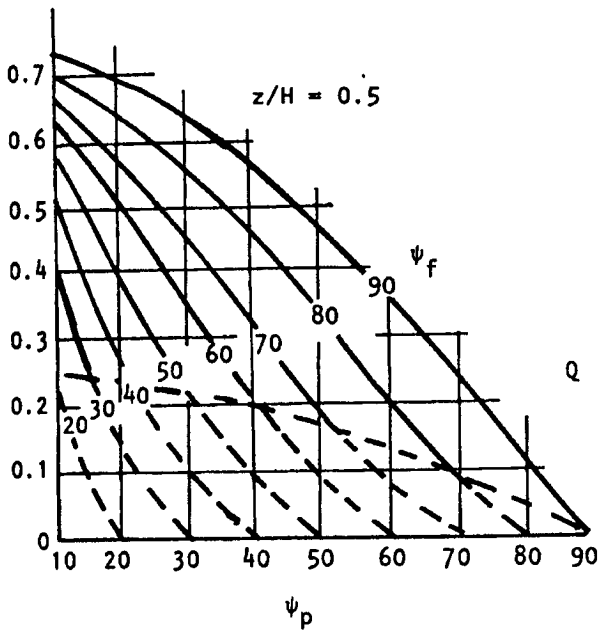

FOR MI 561 GOETECHNICAL ENGINEERING

SOME PARAMETRIC RELATIONSHIPS

$$A = (H-z) \cdot \text{Cosec}\psi_p$$

$$U = 1/2 \gamma_w \cdot z_w (H-z) \text{Cosec}\psi_p$$

$$V = 1/2 \gamma_w \cdot z_w^2$$

$$W = 1/2 \gamma H^2 ((1-(z/H))^2 \text{Cot}\psi_p - \text{Cot}\psi_f)$$

$$P = (1-z/H) \cdot \text{Cosec}\psi_p$$

$$Q = ((1-(z/H))^2 \text{Cot}\psi_p - \text{Cot}\psi_f) \text{Sin}\psi_p$$

$$Q = ((1-z/H)^2 \text{Cos}\psi_p (\text{Cot}\psi_p \cdot \text{Tan}\psi_f - 1))$$

$$R = \gamma_w/\gamma \cdot z_w/z \cdot z/H$$

$$S = z_w/z \cdot z/H \cdot \text{Sin}\psi_p$$

$$F.S = ((2c/H) \cdot P + (Q \cdot \text{Cot}\psi_p - R(P+S)) \text{Tan}\phi) / (Q+R \cdot S \text{Cot}\psi_p)$$

THE UNIVERSITY OF ZAMBIA
FIRST SEMESTER UNIVERSITY EXAMINATION

OCTOBER 2010

MI 585: MINE TRANSPORTATION

TIME : THREE [3] HOURS FULL MARKS : 100

INSTRUCTIONS: ANSWER QUESTIONS 7 AND ANY OTHER FIVE

- (a) Questions to be answered in the way it appears
(b) Neat diagrams and complete calculations are the requirements of this examinations
-

QUESTION 1

- (a) The correct selection of mine transportation equipment is a sensitive issue in terms of satch, economy and efficient mining. Write the major factors that governs the choice of the equipment. **[10 Marks]**
- (b) Write the recommended wire ropes required for the following properties.
- | | |
|-----------------------------|---------------------------------|
| (i) Winding of cage or skip | (iv) as haulage ropes |
| (ii) as 'Guide' ropes | (v) In cable conveyor belts and |
| (iii) In shaft sinking | (vi) Draglines |

How often the holsting rope should be tested as per the requirements of statute and for what parameters? **[6 Marks]**

QUESTION 2

- (a) What are the different types of mine transport system used underground for transportation of minerals, materials and men? Between the locomotives and conveyor belts, compare their merit and demerits. **[10 Marks]**
- (b) What are the most common reasons for the derailments of mine car (or tubs). How the derailment can be controlled. **[6 Marks]**

QUESTION 3

- (a) For underground mineral transport system, conveyor belts are getting more popular particularly the nylon type. Give the reasons for this and recommend the width (in mm) and expected mineral carrying capacity tonnes/hour for use (i) at face or gate roadway (ii) trunk roadway. **[10 Marks]**
- (b) Calculate the mineral carrying capacity (in t/h) if the width of the belt in 1.0m. The bulk density of the materials to be transported is 1.35 t/m^3 and the speed of the belt is 80m/mm. **[6 Marks]**

QUESTION 4

- (a) What are the factors you would consider in the DESIGN of all underground hoisting system? Write the reasons for the parameters you have chosen. **[10 Marks]**

(b) Calculate the fleet angle (in degrees) from the data given below:

➤ Ratio of $(T_1 / T_2) = 2.02$.

where T_1 and T_2 are the weight on the loaded cage and empty cage side respectively and,

➤ Coefficient of friction between the sheave and the winding rope = 0.45

If the fleet angle calculated is not within the recommended range, how can it be corrected? [6 Marks]

QUESTION 5

5 (a) What causes deterioration of winding ropes and how these can be avoided?

[10 Marks]

(b) Name the popular equipment for use for removal of overburden and mineral extraction in a surface mining.

Recommend and describe all equipment which can be used for both removal and soft overburden and mineral. [6 Marks]

QUESTION 6

(a) What are the essential considerations in the DESIGN of a pit – top layout for a cage window? Describe with the help of diagrams a suitable pit – top layout wing “trun tables”. [10 Marks]

(b) Whether the above layout can also be used in ‘skip’ winding system? Of not, suggest a different layout for skip winding with the help of a diagram. [10 Marks]

QUESTION 7

(a) DESIGN a hoisting system for a drum winder required to lift a cage from a 450 m deep shaft. The other details are given below:-

➤ Total weight to be operated = 13 tonnes

➤ Factors of safety for rope should be = 10

➤ Diameter of the drum = 3.0m

➤ Values of [K] and [S] for round strand rope) are 0.36 and 52 respectively.

In the design you are expected to specify (i) the diameter (mm) of the rope (ii) weight of the rope (in kg/m) and (iii) total length of the rope (in mm) keeping in mind the statutory requirement in recommending total length of ropes. [10 Marks]

(b) Write the safety and emergency devices provided in the friction winder system. Write the purpose of the devices provided. [10 Marks]

END OF EXAMINATION

THE UNIVERSITY OF ZAMBIA
UNIVERSITY EXAMINATIONS – OCTOBER 2010
MM 411
COMMINUTION AND CLASSIFICATION

TIME: THREE HOURS

- INSTRUCTIONS: 1. ANSWER QUESTION ONE AND ANY OTHER FOUR
 2. ALL QUESTIONS CARRY EQUAL MARKS
-

Q1

State briefly but clearly what you understand by the following terms, used in minerals engineering:

- (i) Comminution
- (ii) The angle of nip in a crushing operation
- (iii) Classification
- (iv) The angle of repose of a mass of loose material
- (v) Equivalent diameter of a particle
- (vi) Separating size in a classifier in operation
- (vii) Particle size distribution (PSD)
- (viii) A modular particle
- (ix) Semi-Autogenous (SAG) Mill
- (x) Critical speed of a tumbling mill

[20]

Q2

- (a) What do you understand by the term 'reduction ratio'? Outline the various ways in which reduction ratio can be defined. Include in your answer the applications and limitations of the proposed definitions. [4]
- (b) What do you understand by the grindability of an ore? Why does the grindability of an ore frequently vary with size to which the ore is being ground? [3]
- (c) Give the definition of Bond's work index. [2]

The equation for Bond's work index can be written as:

$$W_i = W_{F \rightarrow P} \left[\frac{F^{0.5}}{F^{0.5} - P^{0.5}} \right] \left[\frac{P}{100} \right]^{0.5}$$

What do the symbols used in the above equation represent and in which units should they be expressed? [2]

- (d) (i) A material has a ball mill work index of 15.6 kWh/ton, and a particle size of 80% passing 1 mm. How much energy would be needed to reduce this material to 80% passing 100 μm in a mill 8 feet in diameter? [3]
- (ii) If you want to know the energy required per tonne of this material in the size range 1mm to 36 μm (80% passing size), could you simply use the same equation that you used under 2d(i)? Explain your answer. [3]
- (iii) If it is required to mill 11000 tonnes/day of the material from 1mm to 100 μm in 3 shift operations, with an expected mill availability of 92%, what minimum horsepower should be installed in the grinding section, based upon the above data (1hp = 0.75 kW). [3]

Q3

- (a) Draw a functional sketch of a hydrocyclone in operation, name its parts and describe its separating action (or classification mechanism). Describe how the cyclone efficiency can be expressed and draw two rough diagrams, illustrating this for a high efficiency and a low efficiency cyclone respectively. [6]
- (b) (i) What are the main design variables of a hydrocyclone? [4]
- (ii) For each of these design parameters, give an indication of its relation with the flowrate of the feed, with the cyclone inlet pressure and with the separating size. [6]
- (iii) What can you say about the products from a hydrocyclone as compared to the products of a mechanical classifier? Explain briefly. [4]

Q4

Consider a grinding circuit shown in Figure 1 below, consisting of a rod mill in open circuit and a ball mill in closed circuit with a hydrocyclone: On the basis of Figure 1, answer the following:

- (a) What is understood by the “circulating load” in this circuit? [2]
- (b) How can you express the circulating load as a percentage of the tonnage of fresh feed into the circuit, using only the size analyses of the particle size fractions? [2]

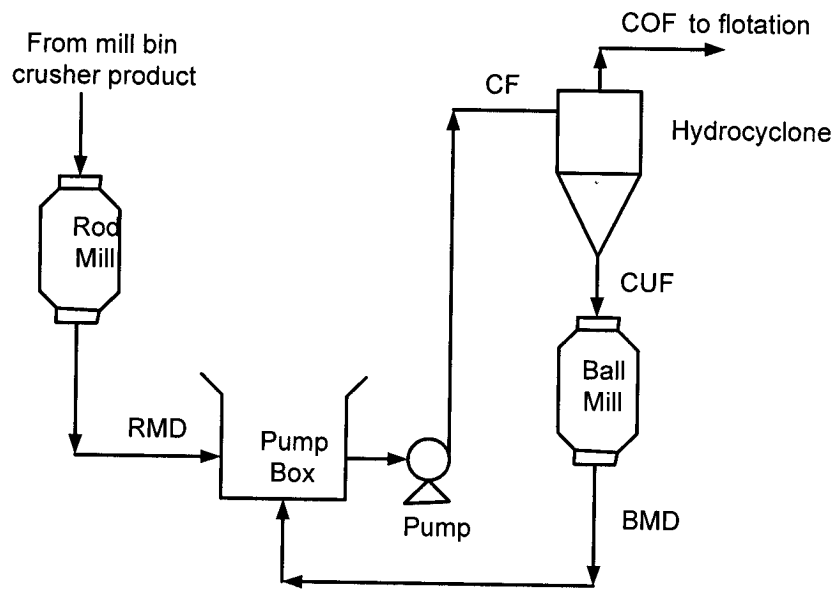

Figure 1: Rod mill-Ball mill-Cyclone Circuit

- (c) Imagine that, as part of a survey of the above circuit, samples are taken of the rod mill and ball mill discharges and of the cyclone overflow and underflow, and that screen analyses of the composite samples gave the following results:

Size fraction [μm]	Weight Percentages Retained			
	RMD	BMD	CUF	COF
+ 212	35.1	24.4	34.9	3.6
+ 150	11.7	21.6	25.1	1.2
+ 106	5.8	25.0	22.5	13.3
+ 75	6.4	13.2	9.2	18.4
+ 53	7.4	10.4	3.9	26.9
- 53	33.6	5.4	4.4	36.6

Calculate the circulating load as a percentage of the new feed over the ball mill/cyclone circuit, based upon these screen analyses. [2]

- (d) If the feed to the rod mill is 95 t h^{-1} (dry weight), what is the actual feed rate to the ball mill, based upon your answer to question (c)? [2]
- (e) What is the size distribution in the cyclone feed, based upon the above data? [4]
- (f) From these data, calculate the recoveries to the cyclone underflow for the different size fractions and plot these against particle size on a graph paper. [4]
- (g) What is the separating size in this cyclone operation, based upon these data? [2]
- (h) What is the “imperfection” in this cyclone operation, based upon these data? [2]

Q5

- (a) (i) In industrial screens, the openings are often rectangular (“slotted”) rather than square. What can you say about the advantages and disadvantages of rectangular openings as compared to square openings in industrial screens?
- (ii) Screens with rectangular openings can be positioned with the largest dimension of the opening in the direction of feeding, or they can be positioned perpendicular to it. What would be the advantage(s) in each case?
- (b) (i) Industrial screens are required to give a number of effects to the particles on the screen. These effects are mainly achieved by shaking and vibrating the screen. List the four most important requirements and explain briefly why each of these effects is important.
- (ii) Describe briefly how these effects can be achieved on a shaking screen with a Ferraris-type of support. You can make a rough sketch as illustration.
- (c) (i) Give four reasons why industrial screening is carried out.
- (ii) Give three reasons for using double-deck screens rather than single-deck screens in concentrator crushing plants.

Q6

- (a) Give a brief discussion on the flow of ore in bins and illustrate this with rough sketches. Discuss problems of segregation, of arching, of piping, of compaction and of dead ore in the bin. [6]
- (b) Roughly sketch the main types of bin design and discuss each of these briefly. [4]
- (c) If, with simultaneous feed and discharge, you see the level of ore in the bin rising, will the discharge of the bin then be coarser, finer or of the same average size as the feed to the bin? And if the level is falling? Explain your answer briefly. [5]
- (d) State briefly why all longer belt conveyors and all inclined belt conveyors should be equipped with a belt take-up. Give and discuss two different types of belt take-up. [5]

Q7

The flowsheet shown (See Figure 2 attached) below is that of a tin concentrator treating 30 dry tonnes per hour of ore.

The ore, containing 10% moisture, is fed into a rod mill, which discharges a pulp containing 65 % solids by weight. The rod mill discharge is diluted to 30% solids before being pumped to cyclones. The cyclone overflows, at 15 % solids, are pumped to the slimes treatment plant.

The cyclone underflow, at 40% solids, and containing 0.9% tin, is fed to a gravity concentration circuit, which produces a tin concentrate containing 45% tin, and a tailing containing 0.2%.

The tailing slurry, containing 30% solids by weight, is dewatered to 65% solids in a thickener, the overflow being routed to the mill header tank, which supplies water to the rod mill feed and rod mill discharge.

Calculate:-

- (i) The flowrate of make-up water required for the header tank [4]
- (ii) The water addition needed to the rod mill feed [4]
- (iii) The water addition needed to the rod mill discharge [4]
- (iv) How much water is contained in the cyclone overflow per hour? [4]
- (v) The recovery of tin to the concentrate [4]

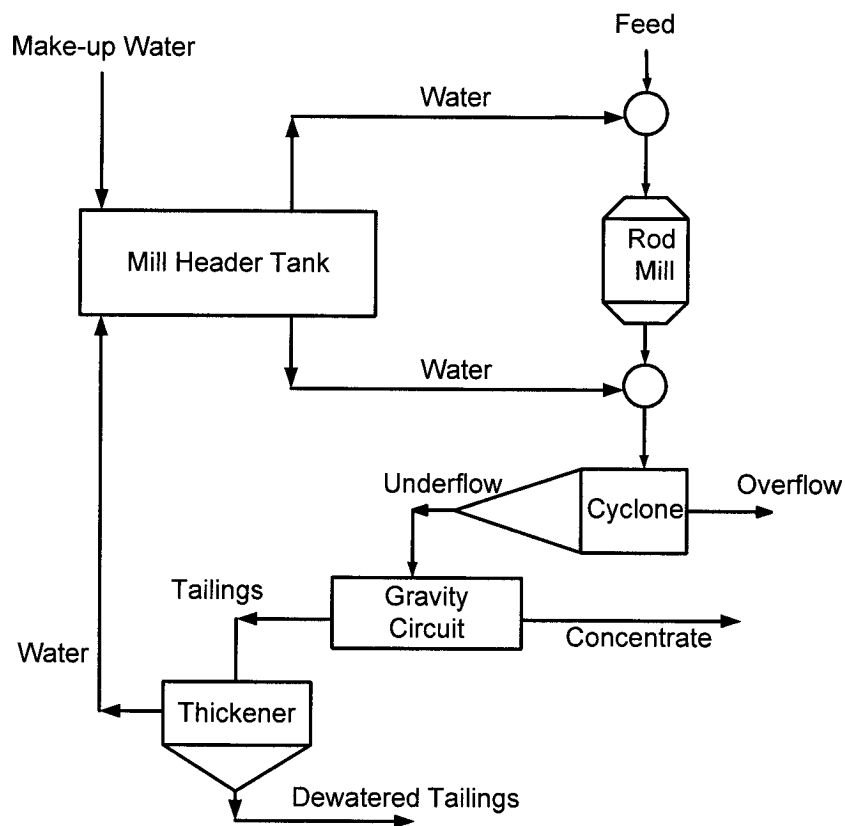

Figure 2: Tin Concentrator Circuit

END OF EXAMINATION IN MM411

THE UNIVERSITY OF ZAMBIA

SCHOOL OF MINES

UNIVERSITY EXAMINATIONS – OCTOBER/NOVEMBER 2010

MM 515 SPECIAL TOPICS IN MINERAL PROCESSING

TIME: THREE HOURS

ANSWER ANY FIVE QUESTIONS AND ALL CARRY EQUAL MARKS

1. First Quantum Plc in Solwezi have just opened a Cu-Co mines with an ore containing 3% Cu in the form of chalcopyrite (CuFeS_2), 0.02% Co as Carrollite (CoCu_2SO_4) and the remainder being predominately siliceous gangue (s.g 2.7). The ore is stage crushed from ROM of about 2000 mm to -12mm and sampled before being further treated. The output from the Gyratory crusher is fed to storage bins via a conveyor system at an average rate of 100 tonnes per hour. Assuming that the crushed material is thoroughly mixed, determine the limit of error (at 99% confidence limited) in the Cu assay introduced by taking a 1kg sample from the conveyor at intervals of $\frac{1}{4}$ an hour. A test of the ore showed that the maximum Cu content of the largest piece in the sample is 10% Cu. The specific gravity of chalcopyrite is 4.2. Take the shape factor and size factor as 0.5 and 0.25 respectively. Discuss the most appropriate sampling method to be used. [20]
2. (a) What are the advantages of using particle size distribution functions over the other methods of presenting sizing data? [5]
- (b) What is the general equation of particle size distribution function. Outline the significance of the parameters with reference to the Guadin-Schulmann and Rosin-Rammler functions. Show the relationship between the two functions. [10]
- (c) A particle size distribution of the ore is known to follow the G.S. function with 90% and 50% of the particle being less than 1mm and 0.5mm respectively. What is the weight percent between $10\ \mu\text{m}$ and $20\ \mu\text{m}$? [5]

3. (a) Explain how an electrical double layer may be formed when minerals are put in a solution. [4]
- (b) What do you understand by the following terms?
- Electrophoresis [2]
 - Streaming potential [2]
 - Electro osmosis [2]
 - Sedimentation Potential [2]

How can you measure the first two and give detailed explanation of how Electrophoresis will lead to establishing the zeta potentials and explain how this may be use in the separation of different minerals. [8]

4. What is the purpose of particle size reduction in mineral processing? [4]
- (i) Give the various definitions of "Reduction Ratio" and identify the most important definitions. [8]
- (ii) In Energy-Size reduction relationships as used in the design of comminution equipment, empirical "laws" are normally used. Name these laws and explain on which basis each one is used. Using a generalised equation derive each on of them. [6]
- (iii) What do you understand by the term "Bond index"? [2]

5. (a) "Only regular geometrical shapes can have their sizes conveniently qualified". Discuss the implications of this statement with regards to:
- (i) The various definition of "size"
 - (ii) Applications of these definitions size. [10]
- (b) Discuss the principle involved in incremental methods and show how the data obtained may be useful. [6]
- (c) Describe the Andreassen pipette and the interpretation/calculation of results. What are the main disadvantages of this apparatus? [4]

$$Z = \frac{e n z}{n}$$

2 → Stern layer potential
3 → diffuse layer → mobile counter ions

Surface area of solid

1 2 3

+

①

6. The following data refer to the adsorption of n-butane at 273 K by a sample of tungsten powder which has a specific surface area (as determined from nitrogen adsorption measurements at 77 K) of $6.5 \text{ m}^2\text{g}^{-1}$:

Relative pressure (p/p_0)	0.04	0.10	0.16	0.25	0.30	0.37
Volume of gas adsorbed/ cm^3 (s.t.p.) g^{-1}	0.33	0.46	0.54	0.64	0.70	0.77

BET equation may be written as:

$$\frac{p}{n(p_0 - p)} = \frac{1}{n_m C} + \frac{(C - 1)}{n_m C} \left(\frac{p}{p_0} \right)$$

Use the BET equation to calculate a molecular area for the adsorbed butane at monolayer coverage and compare it with the value of $32.1 \times 10^{-20} \text{ m}^2$ estimated from the density of liquid butane. Explain the reasons for having two different values. [20]

END OF EXAMINATION IN MM 515

THE UNIVERSITY OF ZAMBIA
SCHOOL OF MINES

2010/11 ACADEMIC YEAR FIRST SEMESTER
FINAL EXAMINATIONS

MM525 MECHANICAL METALLURGY

TIME: THREE HOURS

ANSWER: Question 1 and FOUR other Questions

1. (a) In class, it was stated that the force (or pressure) P required for metal fabrication has three components and can be expressed as

$$P = f(\sigma_0) + f(\mu) + f(C)$$

where σ_0 = yield strength, μ = coefficient of friction and C = geometric factor that is characteristic of the particular mode of working. Explain how each one of these components affects the overall force (or pressure) requirements during metalworking.

- (b) Show that the work for plastic deformation during metalworking is

$$W_{pl} = \frac{VK\Sigma^{m+1}}{m+1}$$

- (c) Justify why during most metalworking processes it is essential to subject the stock material to stress levels that will cause it to yield.

2. (a) Using the sketch below, describe the processes that are taking place during deep drawing as the stock material moves from “a” to “f”.

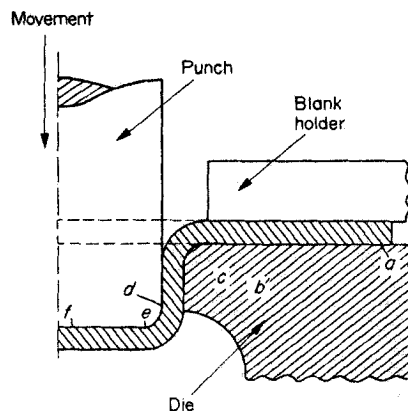

- (b) How will the total load change with punch movement?
(c) Describe the problem of springback during bending.
(d) In class, it was stated that the force for bending P can be expressed as

$$P = \frac{\sigma_o L h^2}{2(R + h/2)} \tan \frac{\alpha}{2}$$

Discuss how each one of the variables in this expression can be optimized in order to minimize the bending force.

3. (a) Why is a cluster mill a much better design as compared to other mills?
- (b) What is the effect of applying front and back tension on the rolling load? Your discussion should include the effect of front and back tension on the size of the “friction hill.”
- (c) Determine the deformed radius of curvature of steel rolls 500 mm diameter, rolling copper strip 800 mm-wide and 75 mm thick, given 20% reduction, if the yield stress of copper is 675 N/mm². For this steel $\gamma = 0.35$ and $E = 2.01$ MN/mm².
- (d) For the steel rolls in question (c), calculate the minimum gauge of steel with a flow stress of 530 N/mm², which can be rolled in this mill ($\mu = 0.135$).

$$P = \sigma_o b \sqrt{R \Delta h}$$

$$C = 16 \frac{(1 - \gamma^2)}{\pi E}$$

$$\frac{R'}{R} = 1 + \frac{CP'}{b \Delta h}$$

$$h_{min} = C\mu R \sigma_o$$

4. (a) Suppose you wanted to punch-out an N-shaped object from the stock material shown below containing a series of horizontal flow lines. Explain why both of the two N-shaped objects depicted here would not be good designs?

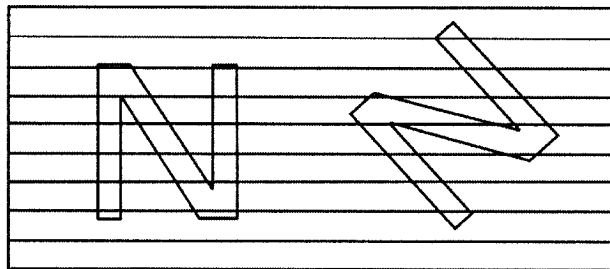

- (b) Discuss how you can come up with a properly designed N-shaped object from the stock material in part (a). Your discussion should include an appropriate sketch of the properly designed N-shaped object.
- (c) For a piece of metal of thickness h , width $2a$ and length l , show that the forging pressure p exerted on it at various points by the press is

$$p = \sigma_o' \left[1 + \frac{2\mu}{h} (a - x) \right]$$

where $\sigma_o' = 1.15\sigma_o$. A von Mises yield criterion for plane strain conditions is

$$\sigma_1 - \sigma_3 = \frac{2}{\sqrt{3}} \sigma_o = \sigma'_o$$

5. (a) What is meant by redundant work in extrusion? With the aid of appropriate sketches, show how you can determine the existence of redundant work during extrusion.
- (b) The curves for the variation of extrusion pressure with ram travel for different types of extrusion are shown below. Justify the differences in the extrusion pressures for these two types of extrusion.

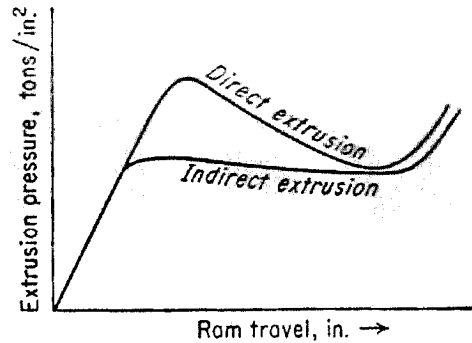

- (c) Where would the curve for hydrostatic extrusion lie with respect to the two curves shown above? Explain your reasoning.
- (d) A 40 mm long, 30 mm diameter billet is used in a direct extrusion press. When its length has been reduced to 20 mm, the extrusion pressure was found to have decreased by 30%. Use this information to estimate the coefficient of friction for the process.

$$p = p_o \exp \frac{4\mu L}{D}$$

6. (a) Tubes made by extrusion and rolling are usually finished by drawing. List the advantages of such tube drawing processes.
- (b) The figure below shows the drawing processes with and without back tension. P = drawing force, T = tension in the stock material, Q = back tension, Y_1 = yield stress of material before drawing and Y_2 = yield stress of material after drawing. Discuss why the presence of back tension does not actually result in savings in amount of work required for drawing.

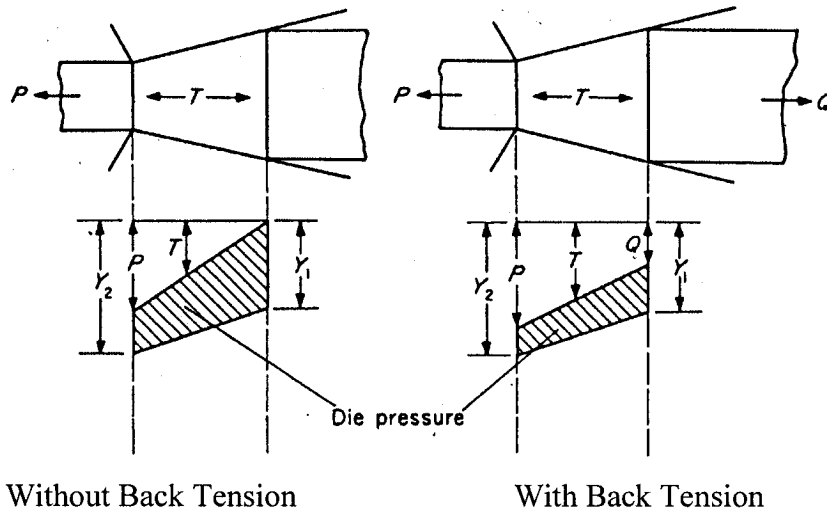

(c) Describe how the presence of back tension reduces die wear by “ringing.”

(d) In class, it was shown that the drawing stress $\frac{P}{A_2}$ in the presence of friction can be expressed as

$$\frac{P}{A_2} = \bar{\sigma}_0 \phi [\mu \cot \alpha + 1] \ln \frac{A_1}{A_2}$$

Discuss how variations in α affects the drawing stress.

What is ϕ and why is it important to include it in such an expression for the drawing stress?

Question	1	2	3	4	5	6
Points	15	18	18	18	18	18

END OF EXAMINATION IN MM525