

THE UNIVERSITY OF ZAMBIA
SCHOOL OF ENGINEERING
SECOND SEMESTER
2012 /2013 ACADEMIC YEAR.

1. EA 421 –Farm Structures
2. EE 209 –Principles of Electricity I
3. EG 269 –Introduction to information Technology
4. EG 479 –Engineering ,Management and Society
5. EG 575 –Engineering, Management and Society II
6. CE 219 –Statistics and Introduction to Strength of Materials
7. CERW 1015 –Procurement, Contract management and supervision
8. ME 232 –Properties of Engineering Materials I

THE UNIVERSITY OF ZAMBIA

SCHOOL OF ENGINEERING

**2013 ACADEMIC YEAR FIRST SEMESTER
FINAL EXAMINATIONS**

26 FEBRUARY 2013

EA 421 – FARM STRUCTURES

TIME: THREE (3) HOURS

INSTRUCTIONS:

ANSWER: ANY FIVE QUESTIONS

INFORMATION:

- 1. THIS EXAMINATION PAPER CONTAINS SEVEN QUESTIONS**
 - 2. ALL QUESTIONS CARRY 20 MARKS**
 - 3. THE MARKS FOR EACH QUESTION ARE GIVEN IN BRACKETS**
-

Question One

- a) The choice of building materials for a construction job is dependent on a number of influencing factors. List any FOUR of these factors. (4)
- b) Defects in timber (wood) make it unsuitable for certain purposes. Defects are classified according to their time of manifestation either as natural or those which arise due poor handling and seasoning. Below is a list of categories of defects which arise from poor handling and seasoning. For each category, mention TWO defects.
 - i. Defects in timber which has not been converted (2)
 - ii. Defects due to poor conversion (sawing) (2)
 - iii. Defects due to poor seasoning (2)
- c) Timber for permanent structures should be treated with a preservative. List FOUR characteristics of an effective preservative. (4)
- d) Generally soil (earth) as a building material, has a number of weaknesses with respect to destructive weather conditions. But these weaknesses can be overcome by using burnt bricks and stabilizers. List THREE ways in which stabilizers increase the soil's resistance to destructive weather conditions. (6)

Question Two

- a) Concrete is a very popular construction material due to its high strength, hardness, durability, imperviousness and the ability to be moulded. Apart from aspects of pouring and curing processes, mention TWO aspects that greatly influence the strength of concrete. (4)
- b) You want to construct a concrete slab for a shed which is 20m long and 10m wide. The slab thickness is to be 7cm. You have the following information at hand:

The recommended nominal mix is 1:3:6.

A 50 kg of cement is equal to 37Litres.

Both river sand and stones are completely dry.

Bulk density of sand is 1400kg/m^3 .

Bulk density of stones is 1600kg/m^3 .

Decrease in volume of the mixture is 30% and there is 5% wastage of concrete.

Determine:

- i. The maximum size of stones to be bought. (4)
- ii. The number of bags of cement that are to be bought. (4)
- iii. The number of tonnes of sand to be bought. (4)
- iv. The number of stones to be bought. (4)

Question Three

- a) Define the following:
- i. Static Equilibrium (3)
 - ii. Statically determinate structure (3)
 - iii. Concentrated load (3)
- b) Consider a suspended floor where loads are supported by a set of equally spaced beams Fig. Q3. If the uniformly distributed load arising from the floor itself and the weight of any material placed on top of it (e.g. stored maize) is 15kN/m^2 .

Determine:

- i. The total load supported by beam B. (4)
- ii. The uniformly distributed load Q (kN/m) supported by beam B. (3)
- iii. The reactions R_1 and R_2 at the ends of beam B. (4)

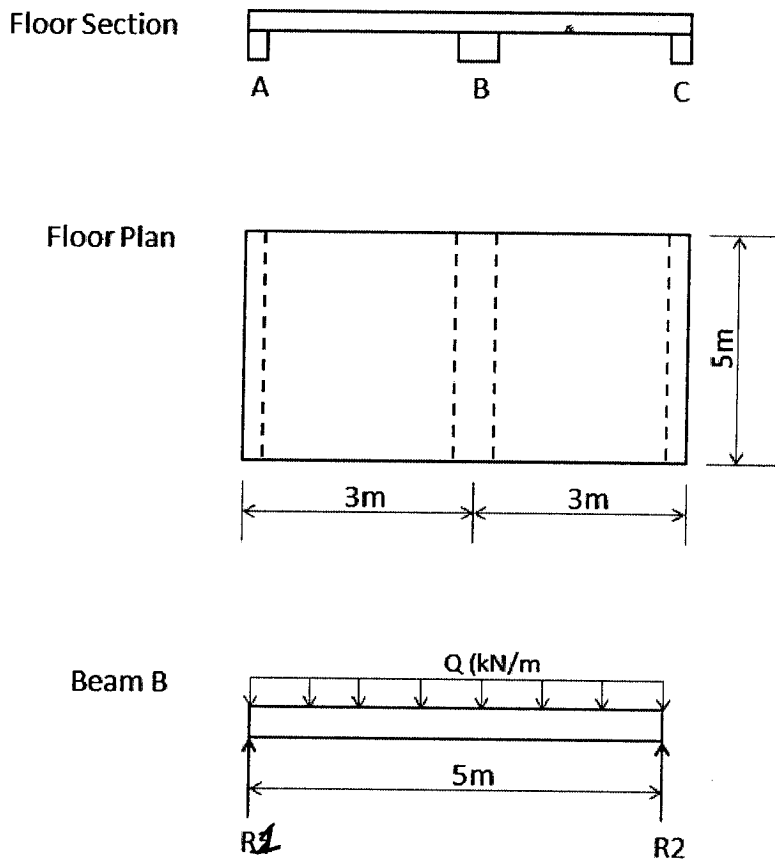

Fig. Q3.

Question Four

A farmer is using a simply supported beam to hoist an engine weighing 6kN from a tractor. The simplified beam and hoist arrangement is shown in Fig. Q4.

- i. Determine the supporting reactions on the beam points A and B. (6)
- ii. Draw the shear force and bending moment diagrams for the beam. (10)
- iii. State the location and the maximum value of the shear force and the bending moment. (4)

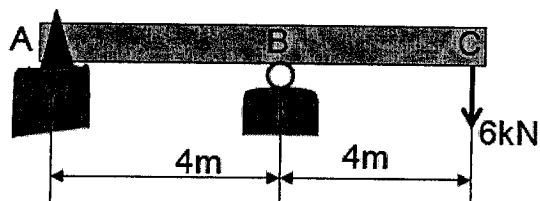

Fig. Q4

Question Five

- a) Environment affects animal comfort and health and ultimately production. It also influences the quality and longevity of stored products. Give THREE aspects that an engineer should be conversant with to enable him/her design structures that can provide the best environment for given farm animals or crops within economic constraints. (4)
- b) Calculate the rate of heat flow across 150mm thick, 3m long and 2m high wall with thermal conductivity $C = 1.45 \text{ W/mK}$. Given that the thermal resistance for air on either sides of the wall is $R_{\text{air}} = 0.11 \text{ m}^2 \text{ K/W}$ and that the temperature difference across the wall is 10K. (6)
- c) The outside air around a green house is 25°C at a relative humidity of 40%. The air is passed through wet pads during which it picks up water vapour amounting to 2g/kg of dry air.
- Determine the relative humidity and temperature of the air after pad cooling. (5)
 - In this case, what would be the lowest temperature possible after pad cooling? (5)

Question Six

- a) Ideally, a building should be on a well drained soil. But sometimes a building can be on a very poorly drained soil. Give FOUR factors that may lead to such deviations. (4)
- b) All buildings are constructed on some kind of a foundation. Typically a foundation starts with a footing. Give TWO functions of a foundation footing. (4)
- c) Foundations may be divided into several categories which are suitable for specific situations. List any FOUR types of foundations. (6)
- d) After foundations are constructed, the upper part of the building called the super structure is build. The super structure should be protected from termites which may attack it if termite control is not done. Give THREE ways of achieving termite control. (6)

Question Seven

- a) List FOUR requirements which a farrowing pen should meet. (4)
- b) A farmer is running a pig unit with 15 sows. The farmer practices the following in rearing his pigs:
It takes an average of 15 days from weaning to the day a sow is successfully mated. The gestating sow is taken to the farrowing pen 7days before farrowing. After farrowing, piglets are weaned at 8weeks but remain in the pen for another 4 weeks. On average, 8 piglets per litter survive to 12 weeks and beyond. The weaners take 5 months to grow and fatten. Then, the pigs are sold immediately.

Apart from the farrowing pens which house 1 sow per pen, the size of the farmer's other pens is such that a pen can house 8 gestating sows or 10 growing/fattening pigs. After any pen is made empty, it is given 7 days (1 week) for cleaning purposes before it is reoccupied. For this purpose, you are told that a year has 365 days; a month has 30 days and that the gestation period for a pig is 3 months, 3 weeks and 3 days.

Determine the following with respect to the farmer's pig unit:

Determine the following:

- i. The number of farrowings per pig per year. (4)
- ii. The number of farrowing pens. (4)
- iii. The number of dry sow/gestating sow pens. (4)
- iv. The number of growing/finishing pens. (4)

SOME USEFUL EQUATIONS

$$\tau_{allowable} \geq \tau_{max} = \frac{4V_{Max}}{3A} = \frac{16V_{Max}}{3\pi d^2}$$

$$I = \frac{1}{12}bd^3$$

$$R_T = R_{air} + R_{wall} + R_{air}$$

$$q = m(h_y - h_x)$$

$$R = \frac{t}{c}$$

$$\tau_{allowable} \geq \tau_{max} = \frac{3V_{Max}}{2A} = \frac{3V_{Max}}{2bd}$$

$$\sigma_{max} = \frac{Mc}{I}$$

$$Q = AU\Delta T$$

END OF EXAMINATION

UNIVERSITY OF ZAMBIA

SCHOOL OF ENGINEERING

**UNIVERSITY SEMESTER I 2012 EXAMINATIONS –
FEBRUARY/MARCH 2013**

EE209

Principles of Electricity I

Time: Three Hours

All Questions carry equal marks

INSTRUCTIONS:

1. This paper is divided into Section A and Section B.
 2. Attempt Five QUESTIONS. Answer at least ONE Question from Section B.
 3. Questions from the two Sections should be answered using different answer booklets and submitted separately.
-

SECTION A

Question 1

- a) Given a two Resistor parallel branch connected to a Current Source , I_s , determine an expression for current in the second resistor **(3 Marks)**
- b) Find R_{AB} , I_T , and I_4 with 10 V, applied ,between A and B, for the Ladder network shown in **Fig Q1b** **(10 Marks)**

Fig Q1b

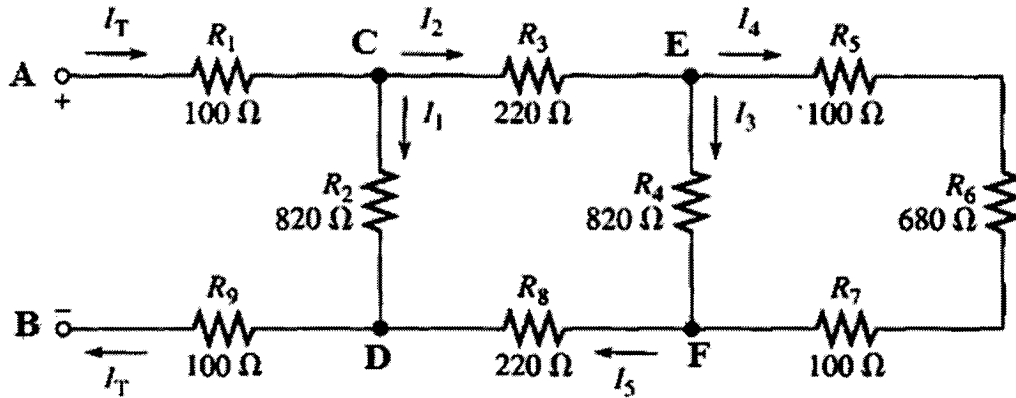

- c) Referring to **Fig Q1b** above, what is the voltage across the Resistor, R_2 , with 20 V applied between A and B? **(3 Marks)**
- d) Referring to **Fig Q1b** above, what is the power dissipated in the Resistors R_4 & R_8 , with 20 V applied between A and B? **(4 Marks)**

Question 2

- a) State Kirchoff's voltage law **(2 Marks)**
- b) Find the mesh currents in the circuit shown in **Fig Q2b** below. **(17 Marks)**

Fig Q2b

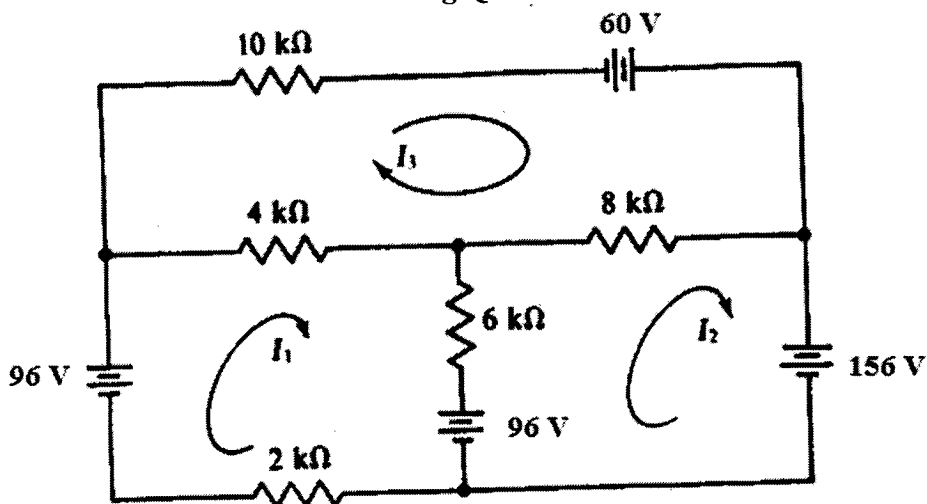

- c) Referring to **Fig Q2b** above determine the current through the $4\text{ k}\Omega$ resistor, in terms of the values calculated in part b) above. **(1 Mark)**

Question 3

- a) The D-Y or Y-D Transformation is a method used for Resistive network reduction. Use this method to find the Resistance, R , for the network shown in **Fig Q3a** below. **(11 Marks)**

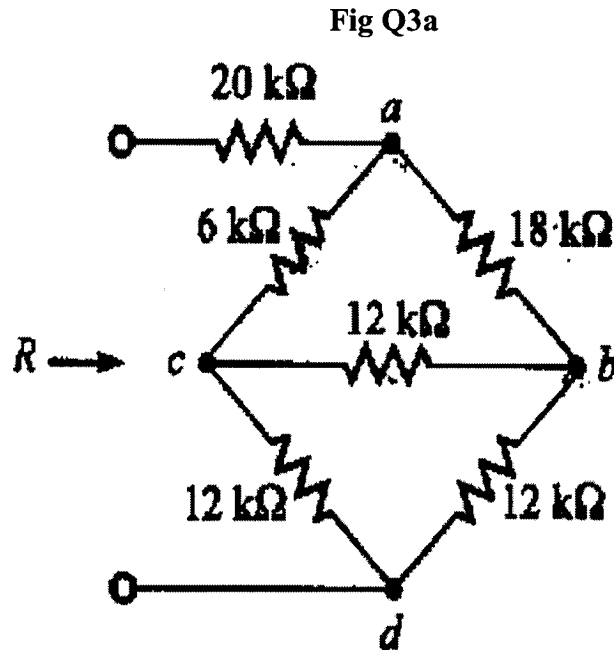

- b) A series R, L and C circuit consists of a $0.5\ \mu\text{F}$ Capacitor, a Coil of inductance $0.35\ \text{H}$ and resistance $20\ \Omega$ and a non inductive Resistor of $30\ \Omega$.
- i). Calculate the resonant frequency of the circuit. **(2 Marks)**
 - ii). This circuit is now connected to a $30\ \text{V}$ ac supply at the resonant frequency. Draw the circuit, then determine the current flow, the voltage across the Coil and the power dissipated in the coil at resonance. **(7 Marks)**

Question 4

- a) Determine the output voltage V_o of the network shown in **Fig Q4a** below, **(12 Marks)**

Fig Q4a

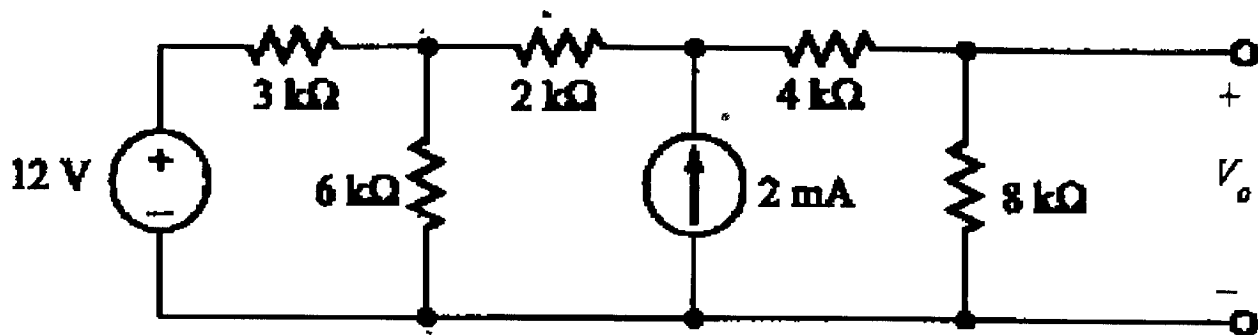

- b) Briefly give a brief statement on any four of the following:- (8 Marks)
- i) The maximum power transfer theorem,
 - ii) Millman's theorem
 - iii) The Superposition theorem
 - iv) Norton's theorem
 - v) Power factor correction

Question 5

- a) A Battery Box contains four car batteries with their positive terminals connected together and the corresponding negative terminals connected together. Their open circuit voltages and internal resistances are: as shown in Table Q5a.

Table Q5a

Open Circuit Voltage(V)	Internal Resistance(Ω)
12.2	0.5
12.1	0.1
12.4	0.16
12.6	0.2

- i) Draw the circuit of the four batteries connected in parallel. (2 Marks).
 - ii) Find the Thevenin voltage, V_{Th} and the Thevenin resistance, R_{Th} of this Battery Box and draw the corresponding equivalent circuit (10 Marks)
- b) A Factory has the following loads connected to the mains supply of 415 V, 50 Hz:
- i). 40 kVA, 0.6 lagging power factor
 - ii). 5 kVA, at unity power factor
 - iii). 10 kVA, 0.8 leading power factor

Determine the active and reactive power components of each load and then the overall power power factor for the Factory. (8 Marks)

SECTION B

Question 6

- a) state three main causes of transients in circuits. **(3 Marks)**
b) Explain why Transients do not occur in purely resistive circuits. **(2 Marks)**

Fig Q6c

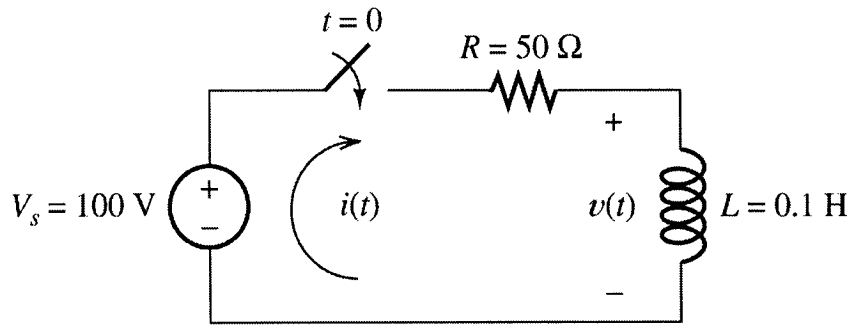

- c) for the circuit of **Fig Q6c** shown above, determine:
- i) The time constant. **(2 Marks)**
 - ii) The steady state current at $t = \infty$. **(3 Marks)**
 - iii) The transient current when the switch is turned on. **(3 Marks)**
 - iv) The total current in the circuit. **(2 Marks)**
- d) state one side effect of transients and explain how you would in practice mitigate its causes in electrical and electronics circuits. **(3 Marks)**

Question 7

a) Show that the current gains for the common base and common emitter transistors are related by $\alpha = \frac{\beta}{1 + \beta}$. (4 Marks)

b) Discuss the formation of a semiconductor PN junction (diode). (5 Marks)

c) The circuit of **Fig Q7c**, below, shows a diode connected in series with a resistor. If $V_{SS}=20\text{ V}$ and $R=5\text{ k}\Omega$.

Calculate :

- i) current at the operating point (Q-Point). (3 Marks)
- ii) Suppose now a germanium diode was used, what would be the current at the Q-point. (3 Marks)
- iii) The maximum current that would be handled by the diode. (3 Marks)
- iv) The maximum reverse voltage. (2 Marks)

Fig Q7c Circuit for Load line analysis

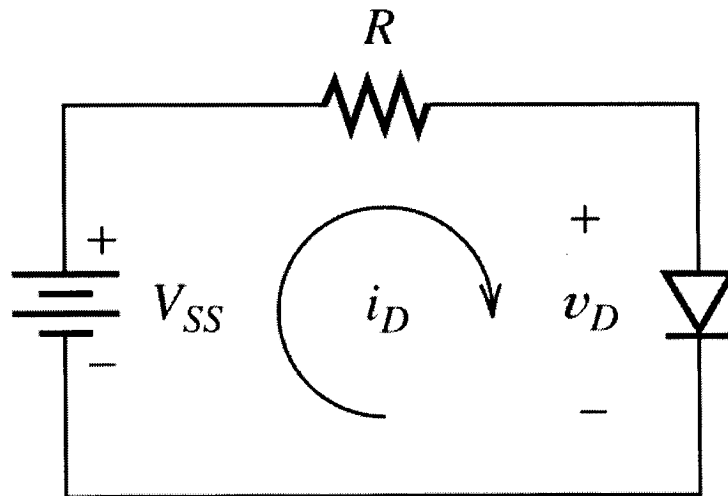

END OF EE209 EXAMINATION FEBRUARY/ MARCH 2013



THE UNIVERSITY OF ZAMBIA

SCHOOL OF ENGINEERING

DEPARTMENT OF ELECTRICAL AND ELECTRONIC ENGINEERING

UNIVERSITY EXAMINATIONS

SEMESTER II – November / December 2012

EG 269

INTRODUCTION TO INFORMATION TECHNOLOGY

TIME : Three (3) hours

INSTRUCTION : Answer *any three* Questions in section A, and *any three(3)* Questions in *Section B*

SECTION A

1.

a) List down the functions of the following internal structure components of the computer:

- Central Processing Unit (CPU)
- Main Memory
- I/O
- System interconnection

[4 marks]

b) Data Packets can be sent on the network from one computer to the other. for the process to take place, Protocol needs to be followed to avoid collision in the data transmission.

- Define the word Protocol.

[1 mark]

- The OSI is made up of ^{Session} 7 layers. Name the last three layer of the OSI ^{Transport} ^{Network}

[3 mark]

- State the function of each named layers ^{Link} ^{Physical}

[3 mark]

- List down any three Protocol, which are located at the first layer and two protocols on the fifth layer of the OSI.

[5 mark]

- Why use the listed protocols within the network?

[4 marks]

2.

a) Define GIS

[1 marks]

- What are the benefits of GIS?

[1 marks]

Geographic representation and cartographic representation abstract observations and measurements about things and events in the world. These abstractions are only useful if they are saved and stored in formats that enable access to them.

- 1) Define ways on how Geographic representation and cartographic representation Can be store and use with the **GIS**

[3 marks]

- b) You have been asked to design a network for the School of Engineering. When carrying out the analysis and design you had to take into consideration several factors which include:

- ✓ The typical physical size of the school,
- ✓ The size and number of computer laboratories,
- ✓ The number of staff (and their categories such as admin, academic, support),
- ✓ The number of students,
- ✓ The placement of servers, network printers etc

- In a tabular form List down:
 1. The topologies needed,
 2. Cables (Transmission Medias)
 3. Network connecting components if any.

[6 marks]

- Draw the designed network with the help of listed materials in **part A**.

[5 marks]

- And with the help an OSI show how data is transmitted from layer to layer

[4marks]

SECTION B-PROGRAMMING

1.

(a) Write a function named "sum from to" that takes two integer arguments, call them "first" and "last", and returns as its value the sum of all the integers between first and last inclusive.

[6marks]

(b) Write a function named "enough" that takes one integer argument, call it "goal" and returns as its value the smallest positive integer n for which 1+2+3+...+n is at least equal to goal.

$a + (n-2)d$ [4 marks]

(c) An arithmetic series is defined by $a+(a+d) + (a+2d) + (a+3d) + \dots + (a+(n-1)d)$

Where a is the first term, d is the common difference, and n is the number of terms to be added. With this information, write a program that uses a while-loop or for loop to display each term and to determine the sum of the arithmetic series having $a=1$, $d=3$, and $n=100$. make sure that your program displays the value it has calculated.

[10 marks]

$$\sum_{n=0}^{\infty} a + (n-1)d$$

2.

Write a function named "location_of_target" that takes as its arguments the following:

- An array of integer values;
- An integer that tells how many integer values are in the array;
- An integer "target value".

for

The function should determine whether:

- a) The given target value occurs in any of the cells of the array, and if it does, the function should return the subscript of the cell containing the target value.

[10 marks]

- b) If more than one of the cells contains the target value, then the function should return the largest subscript of the cells that contain the target value. If the target value does not occur in any of the cells, then the function should return the sentinel value -1.

[10 marks]

3.

You are to write a program using 2 functions as well as main.

The main function should:

1. Prompt the user to enter an integer greater than zero.
2. Pass this integer to a function named isPositive. (the function returns a boolean) and only continue if the number entered is greater than 0. If not the user should be re-prompted to enter a positive integer.
3. Pass this integer to another function called addNumbers.
4. Print out the total returned from the addNumbers function.
5. Allow the user to repeatedly enter integers until they wish to stop.

[20 marks]

4.

(a) The loop shown below has been written by an inexperienced C/C++ programmer. The behavior of the loop is not correctly represented by the formatting.

```
int n = 10;
while (n > 0)
    n /= 2;
    cout << n * n << endl;
```

- 1) What is the output of the loop as it is written?

[1 mark]

- 2) Correct the syntax of the loop so that the *logic* of the corrected loop corresponds to the *formatting* of the original loop. What is the output of the corrected loop?

[2 marks]

- 3) Correct the formatting of the (original) loop so that the new format reflects the logical behavior of the original loop.

[2 marks]

- 4) The following loop is an *endless* loop: when executed it will never terminate. What modification can be made in the code to produce the desired output?

```
cout << "Here's a list of the ASCII values of all
the upper"
```

```
<< " case letters.\n";
```

```
char letter = 'A';
while (letter <= 'Z')
    cout << letter << " " << int(letter) << endl;
```

[5 marks]

(b) Write an application which should be able to accept input from the user, process, temporarily store and display. This input is restricted to the following students' details:

- Last Name: A string with only alphabetic characters. For formatting purposes, you may assume the names would be no longer than 15 characters;
- First Name: A string with only alphabetic characters. For formatting purposes, you may assume the first name would be no longer than 15 characters;
- Computer Number: an integer number. The program should only accept an 8 digit integer.
- Laboratory Results: The program should be able to accept as input results for a given number of laboratory assignments. Maximum number of laboratory assignments should be six (6) and be marked out of 10 marks each.
- Other Assignments Results: The program should be able to accept as input results for a given number of other assignments. Maximum number of these assignments should be eight (8) and be marked out of 10 marks each.
- Mid Semester Test Mark: The mid-semester test is marked and entered out of 100 marks and the program should accept as input only one such test.
- Final Examination Results (End of Semester Exam): The exam is marked and entered out of 100 marks.

Calculations to be performed are as follows:

• **Continuous Assessment (CA)**

- 1) Labs : 15%
 - 2) Assignments : 5%
 - 3) Mid Semester Test : 20%
- Total : 40%**

• **Final Mark**

- 1) CA : 40%
 - 2) Final Exam : 60%
- Total : 100%**

OUTPUT

The program should be able to perform the following functions:

- Add a Student details to the list
- Delete a Student from the list
- Edit Student details
- Searching for a particular student on the list using *Computer Number*, *First Name* and/or *Last Name*
- Display the list of students on the list

[10 marks]

END OF EG269 EXAMINATION



THE UNIVERSITY OF ZAMBIA

SCHOOL OF ENGINEERING

DEPARTMENT OF ELECTRICAL AND ELECTRONIC ENGINEERING

UNIVERSITY EXAMINATIONS
SEMESTER II – August / September 2013

EG 269

INTRODUCTION TO INFORMATION TECHNOLOGY (IT)

TIME	:	Three (3) hours
INSTRUCTIONS	:	<ol style="list-style-type: none">1. This exam paper has Seven (7) questions, organized in Part I (Question 1 – Question 4) and Part II (Question 5 – Question 7); answers to each part must be written in a <u>SEPARATE</u> answer sheet.2. Answer any five (5) questions as follows:<ol style="list-style-type: none">a. Questions one and five (1 & 5) are <u>COMPULSORY</u>;b. The remaining three questions may be chosen from either Part I or Part II.3. Show clearly all working steps leading to the answer.

PART I

Question one

- (a) Describe **with details** the process of computer start-up. **[15 marks];**
- (b) The current computer architecture is known as Von Neumann architecture, name and explain the main weakness of this architecture. **[5 marks];**

Question Two

- (a) A small e-Commerce company whose main business is online marketing has hired you as a trainee Network Administrator. One day, you report to work, only to face a very upset Operations Manager, who comes and says to you that all her Sales consultants are able to send emails, but they cannot receive any reply from customers who query about products and services on offer. This may lead to loss of business. After troubleshooting, you find that on the company's firewall, port 25 is opened and port 110 is blocked. Write a short report (in which you will define a firewall to a lay person) to explain the problem and propose the solution to the Operations Manager. **[5marks]**
- (b) Define the OSI (Open Systems Interconnection) model. What is the importance of the OSI model in the ICT (Information and Communication Technology)? **[7 marks]**
- (c) Select all false statements about TCP/IP **[8 marks]**
- A. Is a 7 layers network stack
 - B. Is a 5 layers network stack
 - C. Has no effect on the Internet
 - D. Is a "descendant" of ARPANET
 - E. Was invented for the year 2000 compliance
 - F. Cannot be used in Africa because the Internet is slow

Question three

- (a) What is the difference between the network router and the network switch? **[6 marks]**
- (b) Contrast the Cache Memory and the register by defining them, explaining their functions and giving their locations. **[6 marks]**
- (c) If a short computer program has two instructions (INSTRUCTION1 and INSTRUCTION2) which are executed sequentially. Please, analyse the following pseudo code below:
INSTRUCTION1 EXECUTED:

PC (Program Counter): AF123C

SP (Stack Pointer): BA780F

INSTRUCTION2 EXECUTING:

If the memory address of INSTRUCTION2 is 01FFDC;

- Define the Program Counter (PC) and write its content after the execution of INSTRUCTION2; [3 marks]
- Define the Stack Pointer (SP) and write its content after the execution of INSTRUCTION2. [3 marks]

- (d) You have taken your laptop to a computer repair shop because it is slowing down. The computer technician says that he has found no fault in your laptop; but you need to upgrade its memory (RAM). What do you understand by RAM upgrade? [2 marks]

Question Four

The Fibonacci number, also known as Fibonacci sequence or Fibonacci series, is by definition given by the following formula:

$$F_n = F_{n-1} + F_{n-2}$$

With seed values: $F_0 = 0, F_1 = 1$.

- (a) Design logical steps which may lead you to developing a C++ program to solve the problem of determining the Fibonacci sequence of any number [8 marks]
- (b) Making use of recursive functions concept and steps designed above, write a C++ program to compute the Fibonacci series of any given number (e.g. $n = 2, 3, 4, \dots$). [12 marks]
- The program should be able to display a message like “ You entered the following number: [value entered], and its Fibonacci series is: [result value]”;
 - The program should be able to check invalid inputs and display error message and ask the user to make another try;
 - If the user enters invalid inputs for six consecutive times, the program should display as “FATAL ERROR, the program is exiting!!! Press any key”.

PART II

Question Five

- (a) Write C++ program to display a table that represents a Pascal triangle of any size. In Pascal triangle, the first and the second rows are set to 1. Each element of the triangle (from the third row downward) is the sum of the element directly above it and the element to the left of the element directly above it. See the example Pascal triangle (size=5) below: [20 marks]

1					
1	1			*	
1	2	1			
1	3	3	1		
1	4	6	4	1	

Question Six

(a) The following program prints out a table of shop closing times. It uses a named enumeration to define a new data type "Day", and a function "closing_time(...)" to generate the closing time from a given day (not a complicated function - the shop closes at 5pm every day). The program illustrates how the identifiers "int" and "Day" can both be used as type casts (in the head of the "for" loop and in the call to "closing_time(...)" respectively):

I. What happens (and why) if we try to replace the "switch" statement with the single line

```
cout<<static_cast<Day>(count);    ?
Replace the "switch" statement with the line
print_day(static_cast<Day>(count), cout);
```

instead, and add an appropriate definition after the main program for the function "print_day(...)", using a "switch" statement (don't forget the function declaration as well). ("cout" is of type or class "ostream").

[7 marks]

II. The shop keeper wants to change the closing times to 1pm on Sundays, 5pm on Saturdays, 8pm on Wednesdays, and 6pm all other days. Make appropriate changes to the function "closing_time(...)" using a "switch" statement, and test the program.

[13 marks]

Question Seven

Write a program which reads 5 numbers into an array and prints out the value of each and every number which has a value less than 10.

[20 marks]

END

**UNIVERSITY OF ZAMBIA
SCHOOL OF ENGINEERING**

**2013 ACADEMIC YEAR SECOND SEMESTER
FINAL EXAMINATION**

EG 475 – ENGINEERING, MANAGEMENT AND SOCIETY

TIME: THREE HOURS

INSTRUCTIONS

1. Answer one question from each section
-

SECTION A

1. (a) Explain, the term 'balance of payment' and explain in what ways might be attempted correction of a balance of payments deficit by central government hinder the operations of firms in the economy. (20 marks)
- (b) If price rises, demand will fall. If demand rises, price will rise. Explain these two statements and support your answer with graphical presentations. (15 marks)
2. (a) What is meant by the term national income? And what are the main problems involved in its calculation with particular reference to its suitability as indicator of the standard of living. (20 marks)
- (b) What are the factors which influence the quantity of a good supplied? And how is the equilibrium price and quantity of a good determined? Support your answer with illustration. (15 marks)

SECTION B

3. Critically discuss reasons for industrialization in developing countries and state the links between industrialization and economic development. (30 marks)
4. (a) Explain the importance for a developing country like Zambia to have a specific industrial strategy and suggest some industrial options. (15 marks)
- (b) It is said that capital accumulation is a critical factor for industrialization discuss. (15 marks)

SECTION C

5. (a) Explain the significance of accounting in business success and state the role of profit in business and its determination. (10 marks)
- (b) At the end of her trading on 31 December 2012, Emily Mwanza has the following accounts: Opening stock K825; purchases K40,785; sales K92,725, purchases returns K615; sales returns K725. A check on her stock in hand gives a total for closing stock of K1,295. Prepare her Trading Account and discover the gross profit for the year. (15 marks)
- (c) Explain the critical success factors for an entrepreneur. (10 marks)

**UNIVERSITY OF ZAMBIA
SCHOOL OF ENGINEERING**

2012 ACADEMIC YEAR SECOND SEMESTER

FINAL EXAMINATION

EG 475 – ENGINEERING, MANAGEMNT & SOCIETY

TIME: THREE (3) HOURS

INSTRUCTIONS

1. Answer one question from each section
 2. All questions carry equal marks
-

SECTION A

1. (a) Critically discuss the price elasticity of demand. Your answer should bring out the fact that elasticity varies along the demand curve. (20 marks)
- (b) Explain income elasticity of demand. Use illustration to support your answer. (15 marks)
2. Critically discuss the importance of balance of payment to national economy and how a country can rectify deficit on the current account and the capital account. (35 marks)

SECTION B

3. (a) Critically discuss the importance of industrial development in national development (use Zambia as an example). (15 marks)
- (b) Explain the need for technology to support industrial development and state key considerations in selecting technology. (20 marks)
4. Critically discuss the significance of industrial strategy for a developing country like Zambia and explain the need for capital accumulation to support industrialisation. Give examples of capital accumulation.

SECTION C

5. (a) Explain the idea of a balance sheet and why it is of critical importance to business. (15 marks)
- (b) Prepare John Banda's Balance Sheet from the Trial Balance given below:

Trial Balance (John Banda) as at 31 December 2011

	Dr	Cr
Cash in hand	150.00	
Cash at Bank	6,850.00	
Stock at Close	4,500.00	
Debtors	1,600.00	
Motor Vehicles	5,000.00	
Land and Buildings	40,000.00	
Office Equipment	2,000.00	
Plant and Machinery	13,000.00	
Capital (at start)		43,000.00
Net Profit		8,000.00
Mortgage on Premises		25,000.00
Creditors		1,850.00
Drawings	4,750.00	
	<u>77,850.00</u>	<u>77,850.00</u>

6. (a) Explain entrepreneurship process and state clearly how an entrepreneur measures success in business. (15 marks)
- (b) Generally in order to obtain financing for the business the entrepreneur must develop a business plan. Explain issues that the business plan MUST address and state why have a Business Plan for an Entrepreneur. (15 marks)

END OF EXAMINATION



THE UNIVERSITY OF ZAMBIA
SCHOOL OF ENGINEERING
DEPARTMENT OF MECHANICAL ENGINEERING
2012 ACADEMIC YEAR SECOND SEMESTER
FINAL EXAMINATIONS
AUGUST 2013

EG 575-ENGINEERING, MANAGEMENT AND SOCIETY II

Read the following instructions carefully before you start writing.

1. This is a Closed Book examination.
 2. Calculators are permitted.
 3. Time allowed is Three (3) Hours.
 4. ANSWER Any Five (5) questions, at least Two (2) from each section.
 5. Answers in each section should be in separate books.
-

SECTION A:

1. (a) What is the role of a job description for (i) employer, (ii) employee? **(5 Marks)**
 (b) Discuss the four marketing mix. **(5 Marks)**
 (c) Describe the two-tier of corporate hierarchy and how they are appointed. **(5 Marks)**
 (d) Name and briefly describe the two main areas to consider when managing Human Resource if they are to work effectively. **(5 marks)**

2. (a) Briefly explain four items that can be considered when preparing personnel specifications. **(10 Marks)**
 (b) Name and discuss the three managerial skills. **(10 marks)**

3. (a) How do the many roles of the Chief Executive Officer relate to his/her roles as organizational planner? **(4 marks)**
 (b) Contrast between strategic planning and tactical planning **(6 marks)**
 (c) Discuss all the steps of the strategy management process, highlighting the main components of each step. **(10 marks)**

4. (a) Discuss the term “universality of management” **(2 marks)**
 (b) What are the six steps that comprise the planning process? **(6 marks)**
 (c) What are the three duties of planners? **(6 marks)**
 (d) Discuss the two qualities managers are often expected to possess in their use of resources. **(6 marks)**

SECTION B:

5. (a) What is quality control, and how does it differ from quality assurance? **(3 Marks)**
 (b) Define a quality management system and what purpose does it serve? **(4 Marks)**
 (c) Discuss any four of the eight principles of Quality Management Principles. **(7 Marks)**
 (e) Who and what are the roles of the three parties to the industrial relations triangle? **(6 Marks)**

6. The activities, their durations and precedences for designing, writing and installing an **Innovations** computer database are shown in Table Q6b. Draw a network diagram for the project and calculate the fastest time in which the operation might be completed.

TableQ6 Innovations computer database activities

	<i>Activity</i>	<i>Duration in weeks</i>	<i>Activities that must be completed before it can start</i>
1	Contract negotiation	1	–

2	Discussions with main users	2	1
3	Review of current documentation	5	1
4	Review of current systems	6	2
5	Systems analysis (a)	4	3, 4
6	Systems analysis (b)	7	5
7	Programming	12	5
8	Testing (prelim)	2	7
9	Existing system review report	1	3, 4
10	System proposal report	2	5, 9
11	Documentation preparation	19	5, 8
12	Implementation	7	7, 11
13	System test	3	12
14	Debugging	4	12
15	Manual preparation	5	11

(20 marks)

7. Explain the meaning of the following terms as they relate to agreements or contracts. In each case citing a practical application (or example) in an Engineering Organization:

- a) Parties competent to contract (5 Marks)
- b) Lawful consideration (5 Marks)
- c) Certainty of meaning (5 Marks)
- d) Possibility of performance (5 Marks)

8.

- a) Differentiate between the terms Lease and Concession (8 Marks)
- b) The National Electricity Utility Intends to increase power availability by constructing a new transmission line and also rehabilitate and upgrade the existing line. They have decided to enter into a partnership with the private sector who have the availability to mobilize the requisite resources for the project.

As an advisor, which PPP option would you recommend? Give reasons for your preference. (12 Marks)

END OF EXAMINATION

THE UNIVERSITY OF ZAMBIA

School of Engineering

Department of Civil & Environmental Engineering

CE 219-Statics and Introduction to Strength of Materials

Semester 1-Academic Year 2012/2013

FINAL EXAM

March 2013

Time allowed: Three hours

CLOSED BOOK Examination

Instructions to candidates:

1. Candidates must ensure that their computer numbers are clearly written on each answer sheet
2. Answer ANY THREE questions from Section A, and ANY TWO from Section B. All questions carry equal marks (20%)
3. Sections A and B should be answered in separate answer sheets and handed in separately.

Section – A.

Question A-1

- (a) Determine the magnitude and direction of the resultant force acting on the figure shown below. Clearly show your sign convention in your working.

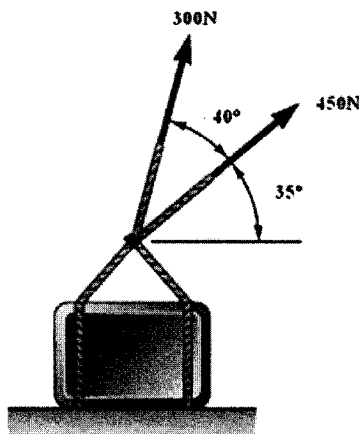

[10 marks]

- (b) A steel bar ABCD 4m long and with a modulus of elasticity of 200GPa is subjected to forces as shown below.

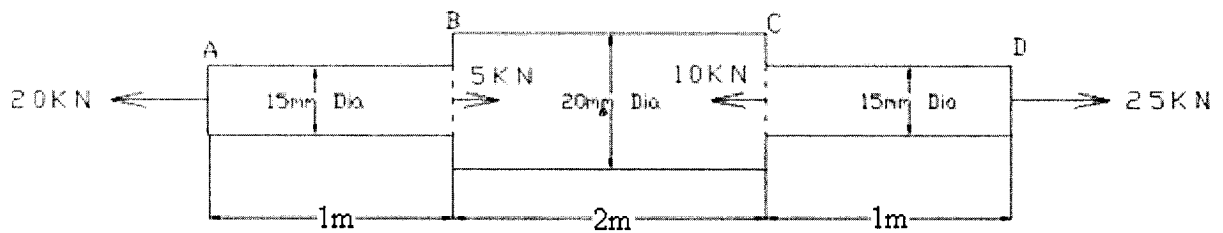

Determine the strain in section BC of the steel bar.

[10 marks]

Question A-2

- (a) The beam shown in figure below is pin connected at A and rests against a roller at B. Compute the magnitude and direction of the reaction force at B.

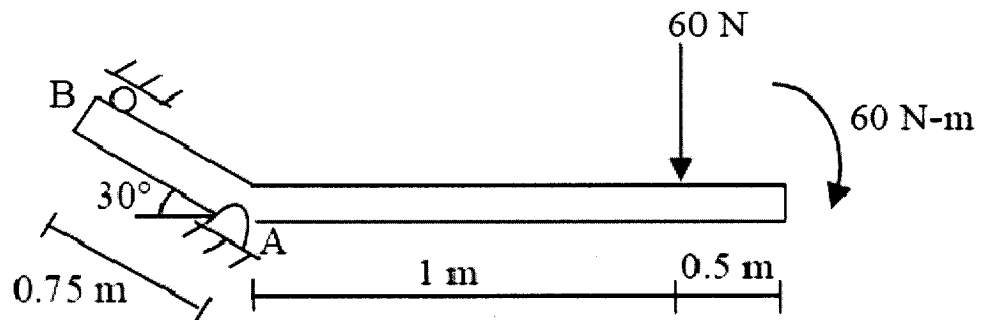

[10 marks]

- (b) The steel beam shown below has a pinned support at end A and a roller support at end B. Determine the minimum clearance (in mm) between end B of the beam and wall C if no longitudinal stresses due to temperature changes are to develop in the beam. The maximum temperature change the beam is exposed to is from 10C to 35C and the coefficient of linear expansion of steel α as $11 \times 10^{-6} / ^\circ\text{C}$.

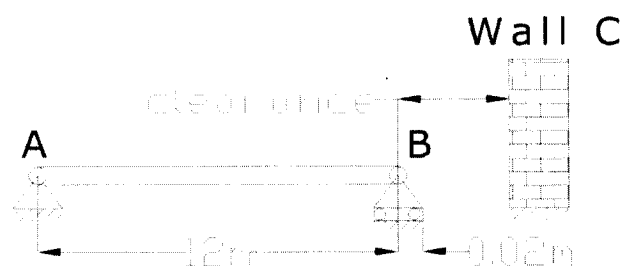

[10marks]

Question A-3

The truss bridge shown below is pinned supported at A and rests on a roller at D.

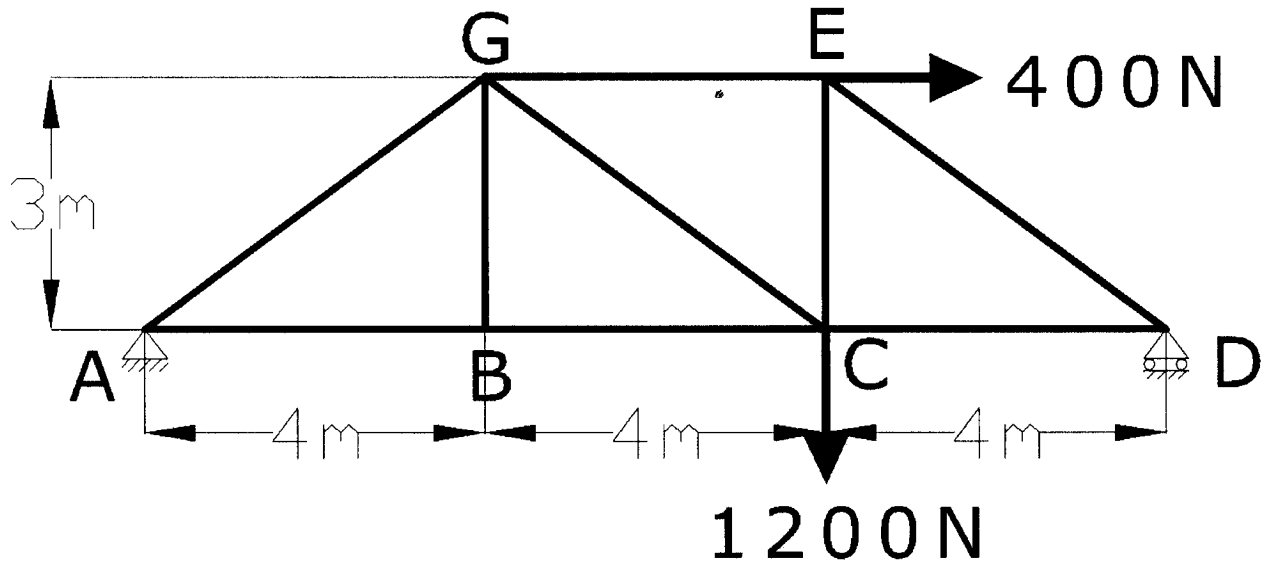

- (a) Determine the force in member GE of the bridge truss shown above and indicate whether the member is in tension or compression. Assume that all member to member connections are pin connections. [15 marks]
- (b) Determine if the pin at A will fail due to shear stress given that its shear strength is 5MPa. The pin is in double shear and has a diameter of 20mm. [5 marks]

Question A-4

- (a) A force equal to 50 N presses down on the top of a book that weighs 30 N, which rests on the horizontal surface of table. The coefficients of friction between the book and the table are $\mu_s = 0.4$ and $\mu_k = 0.3$. Determine the force P at which the book first starts to slip along the surface.

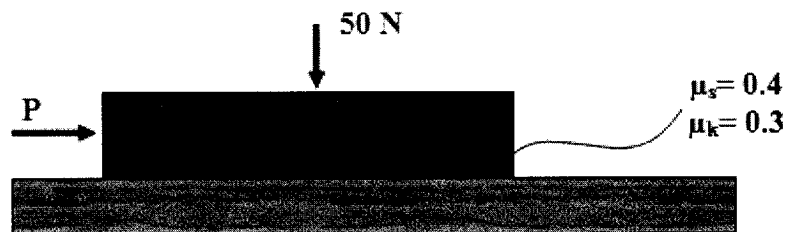

[5 marks]

(b) The state of stress at a point in a member is as shown on the stress element below.

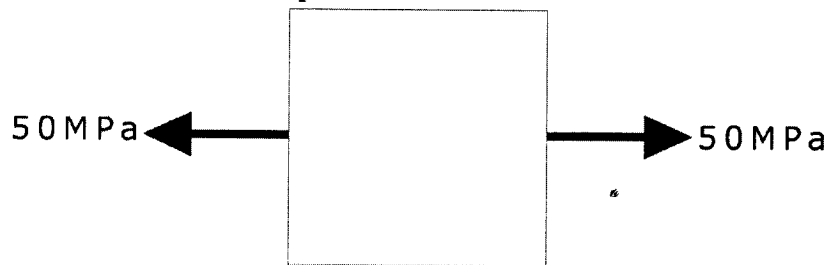

- (i) Determine the maximum in plane shear stress and associated normal stress using a Mohr circle diagram. You are allowed to use trigonometric relations to sketch your Mohr circle diagram. **[6 marks]**
- (ii) Using the Mohr circle diagram drawn in [4b(i)] show the correct orientation of the plane on which the maximum in plane shear stress occurs by using a sketch of the given stress element. **[4 marks]**

Section – B.

Question B-1

- (a) A rectangular hole 20mmx40mm is made into the rectangular plate shown below. Compute the moment of inertia of the plate about the K-K.

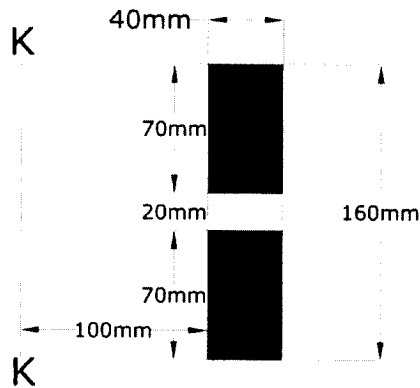

[10 marks]

- (b) Draw the bending moment diagram for a cantilever beam of span 1.5m carrying point loads as shown in the figure below.

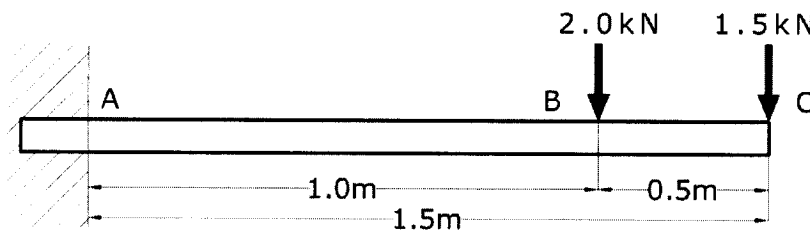

[10 marks]

Question B-2

- (a) For the pliers shown below determine the minimum load P required to be applied to cut a wire placed at point B. The wire has shear strength of 85MPa and a diameter of 30mm.

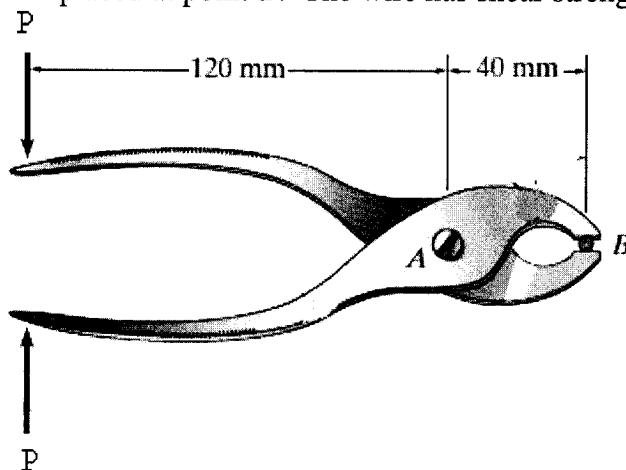

[10 marks]

(b) Due to a loading a plate is deformed into the dashed shape as shown below. Determine the average shear strain γ_{xy} relative to the x and y axes.

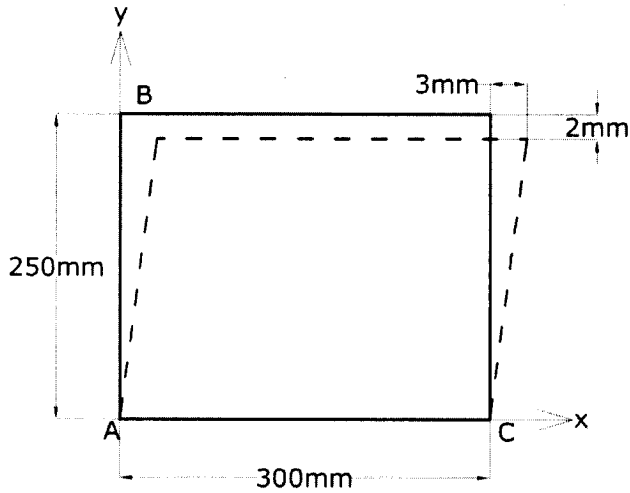

[10 marks]

Question B-3

Determine the horizontal and vertical force components acting at the pin connections B and C of the frame shown in the figure below. Assume that all member to member connections are pinned, the support at A is fixed and that the pulley at E is frictionless. Take $g=9.81\text{m/s}^2$

[20 marks]

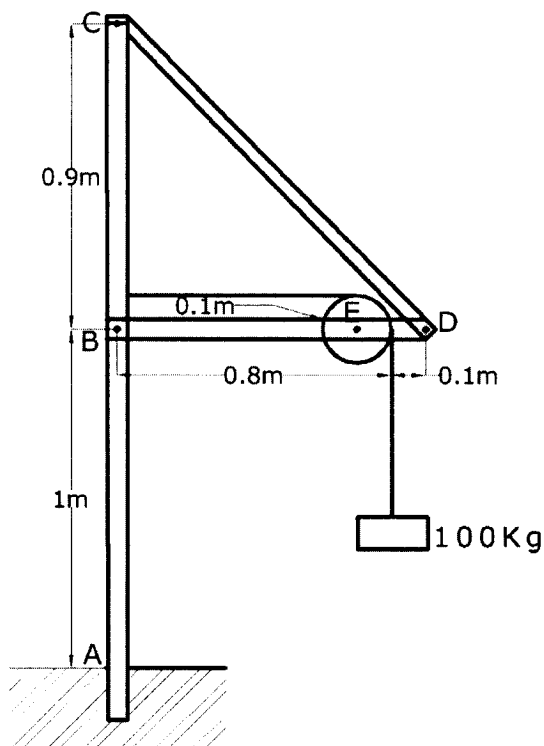

THE UNIVERSITY OF ZAMBIA
SCHOOL OF ENGINEERING
DEPARTMENT OF CIVIL AND ENVIRONMENTAL ENGINEERING
RURAL WATER SUPPLY AND SANITATION CERTIFICATE PROGRAMME

2012/2013 ACADEMIC YEAR
CERW 1015 – PROCUREMENT, CONTRACT MANAGEMENT AND SUPERVISION
UNIVERSITY EXAMINATIONS

8th August, 2013

TIME: THREE (3) HOURS

CLOSED BOOK

=====

INSTRUCTIONS TO CANDIDATES

1. THE PAPER CONTAINS SIX QUESTIONS. YOU ARE REQUIRED TO ATTEMPT ANY FOUR
2. ALL QUESTIONS CARRY EQUAL MARKS WHICH ARE INDICATED UNDER EACH RESPECTIVE QUESTION
3. YOU CAN ANSWER THE QUESTIONS IN ANY ORDER BUT YOUR SOLUTIONS NEED TO BE CLEARLY NUMBERED
4. WHERE INFORMATION IS NOT GIVEN, MAKE AND STATE YOUR ASSUMPTIONS
5. MARKS WILL BE LOST FOR UNTIDY AND UNORGANISED PRESENTATION
6. THE EXAMINATION IS STRICTLY CLOSED BOOK

QUESTION ONE

- a) When can an "Agreement" between 2 parties be referred to as a Contract.
- b) Briefly describe 4 essential elements of a Valid Construction Contract.

[9 + 16]

QUESTION TWO

- a) Define the terms drawing and specifications.
- b) How do drawings and specifications compliment each other in engineering contracts?

[10 + 15]

QUESTION THREE

- a) Name the public entity responsible for regulating public procurement in Zambia and the legal statute under which it was established?
- b) Briefly describe 2 major functions of the entity responsible for regulating public procurement in Zambia.

[11 + 14]

QUESTION FOUR

Read the following statement:

"The Employer shall retain from each payment due to the Contractor the proportion stated in the Contract Data until Completion of the whole of the Works"

- a) What does the statement refer to?
- b) What is the importance of the item referred to in 4a with respect to repair and prevention of project defects?

[10 + 15]

QUESTION FIVE

- a) List 5 common objectives of project monitoring?
- b) Draw a template of a GANTT Chart (Work Programme) for any project of your choice clearly showing all the key headings?

[15 + 10]

QUESTION SIX

Write Short Notes on the 4 essential requirements for GOOD MAINTENANCE practice to be ensured in RWSSU projects.

[25]

**END OF EXAM
GOOD LUCK!**

INB /CERW 1015/EXAM/2013

**THE UNIVERSITY OF ZAMBIA
SCHOOL OF ENGINEERING
DEPARTMENT OF MECHANICAL ENGINEERING**

UNIVERSITY EXAMINATIONS

**FINAL EXAMINATION FOR SEMESTER II 2012
AUGUST/SEPTEMBER 2013**

ME 232 - PROPERTIES OF ENGINEERING MATERIALS I

Time Allowed: Three (3) Hours

This Examination is Closed Book

Answer Five Questions (Two from Section A and Three from Section B.)

Hand in Sections A and B in Separate answer books

All questions carry equal marks

SECTION A - Answer two (2) questions from this Section.

- Q1. (a) Draw a fully labelled Fe-C phase diagram up to 6.7% Carbon. **[12 marks]**
- (b) With reference to your Fe-C phase diagram, for two plain carbon steels of 0.4% and 1.0% Carbon;
- (i) Calculate the amount of austenite present in each of these steels at 723°C, assuming the transformation is complete. **[2 marks]**
- (ii) Calculate the amount of pearlite present in each of these steels at 25°C, assuming slow cooling. **[2 marks]**
- (iii) Suggest a typical application for each steel in its fully hardened and tempered conditions, and justify your choice. **[4 marks]**
- Q2. (a) What is electrochemical corrosion? **[5 marks]**
- (b) Explain concisely each of the following forms of metallic corrosion
- (i) Pitting **[5 marks]**
- (ii) Corrosion fatigue **[3 marks]**
- (iii) Stress corrosion **[3 marks]**
- (iv) Fretting corrosion **[4 marks]**

- Q3. Assuming that metal crystals can be considered as hard spheres in contact, determine the co-ordination numbers and packing fractions for the following crystal structures:
- (a) Body-centred cubic [6 marks]
 - (b) Face-centred cubic [7 marks]
 - (c) Hexagonal close-packed. [7 marks]
- [Hint: Packing fraction = (volume of atoms in unit cell)/ (volume of unit cell)]

SECTION B - Answer three (3) questions from this Section.

- Q4. (a) A Brinell hardness test was conducted on a metal sample. The ball was 10-mm-diameter, the load was 60 kg. The diameter of the indentation was 2.2 mm. Calculate the hardness of this material. [4 marks]
- (b) What will be the diameter of an indentation to yield a hardness of 200 HB when a 400-kg load is used? [4 marks]
- (c) For a brass alloy, the following engineering stresses produced the corresponding plastic engineering strains, prior to necking:

<i>Engineering Stress (MPa)</i>	<i>Engineering Strain</i>
315	0.105
340	0.220

On the basis of this information, compute the engineering stress necessary to produce an engineering strain of 0.28. [12 marks]

- Q5. There is a group of natural materials that are neither good conductors nor good insulators. These are called semiconductors such as Silicon and Germanium. These are used to make a range of devices that are used in modern electronic circuits.
- (a) Briefly explain with reference to band structure and energy levels, the difference between intrinsic and extrinsic semiconductors. [10 marks]
 - (b) Describe briefly how semiconductor materials can be used to produce a light-emitting diode (LED). [10 marks]

Q6. Heat treatment of plain carbon steels allows a wide range of mechanical properties to be achieved. Give details of the following heat treatments including the temperature ranges used, microstructural changes that occur, typical alloy compositions suitable for each treatment and reasons to carry out the treatment:

- (a) Process annealing; [10 marks]
- (b) Full annealing; [10 marks]

Q7. (a) Polyethylene is the simplest of the thermoplastics. Show three ways to represent the structure of this segment of a polymer. The structure should include the following:

- (i) a solid three-dimensional model, [2 marks]
 - (ii) a three-dimensional “space” model, [2 marks]
 - (iii) a simple two-dimensional model. [2 marks]
 - (iv) general description of the polymer. [4 marks]
- (b) With the aid of sketches describe the following polymers:
- (i) linear unbranched polymer [2 marks]
 - (ii) linear branched polymer, [2 marks]
 - (iii) thermoset polymer without branching, [3 marks]
 - (iv) thermoset polymer that has branches and chains. [3 marks]

END OF ME 232 FINAL EXAMINATIONS, AUGUST 2013
G M Munakaampe & V Musonda (Brig Gen)