

# **THE UNIVERSITY OF ZAMBIA SCHOOL OF NATURAL SCIENCE**

## **2009/10 SECOND SEMESTER**

1. BS349- MICROBIOLOGY
2. BS349 –MICROBIOLOGY
3. C342- INORGANIC CHEMISTRY III
4. C362-COLLOIDS AND ELECTROCHEMISTRY
5. CS4012- ADVANCED OPERATING AND DISTRIBUTED SYSTEMS
6. CST 2032- FUNDAMENTALS OF COMPUTER ARCHITECTURE
7. CST2041- INTRODUCTION TO OPERATING SYSTEMS
8. CST2041- INTRODUCTION TO DATA BASES AND FILE SYSTEMS
9. CST2041- INTRODUCTION TO DATA BASES AND FILE SYSTEMS
- 10.CST3032- ARTIFICIAL INTELLIGENCE FUNDAMENTALS
11. CST4122- FUNDAMENTALS OF COMPILERS
- 12.CST4131- ADVANCED OBJECT ORIENTED PROGRAMMING WITH  
JAVA
- 13.CST4122- FUNDAMENTALS OF COMPILERS
- 14.CST4132- COMPUTER GRAHPICS
- 15.GEO175- INTRODUCTION TO MAPPING TECHNIQUES IN  
GEOGRAPHY
- 16.GEO212- GEOGRAPHY OF ZAMBIA
- 17.GEO 995- ENVIRONMENT AND NATURAL RESOURCE  
MANAGEMENT

18. LSE 322 -GEOGRAPHY TEACHING METHODS

19.M112 –MATHEMATICAL METHODS II-A

20 .M222- LINEAR ALGEBRA II

21 .M232- REAL ANALYSIS II

22.M412- FUNCTIONS OF A COMPLEX VARIABLE II

23.M432 –REAL ANALYSIS VI

24.P252 –CLASSICAL MECHANICS II

25.P272 –THERMAL PHYSICS AND OPTICS

24 P332- STATISTICAL PHYSICS

25 P412 –NUCLEAR PHYSICS

26 .P445- QUANTUM MECHANICS II

**THE UNIVERSITY OF ZAMBIA**  
**SCHOOL OF NATURAL SCIENCES**

2009-2010 ACADEMIC YEAR SECOND SEMESTER  
FINAL EXAMINATIONS

BS 349: MICROBIOLOGY  
PRACTICAL PAPER

TIME: TWO HOURS

INSTRUCTIONS: ANSWER ALL QUESTIONS.

---

1. Prepare slides on specimens **A** and **B** using Gram stain procedure and determine whether the two specimens are Gram positive or Gram negative. State so on the prepared slide.

Indicate your computer number on each slide and submit the preparations for examination.

2. Using a 'Hanging Drop Technique' test motility of the provided cultures marked **C** and **D**.

Examine the prepared slides microscopically and identify which of the two cultures shows motility. Submit the prepared slides for examination and evaluation, indicating your computer number on each slide.

3. Describe the procedure in full used to demonstrate the presence of flagellum/flagella in motile bacteria.
- 

END OF EXAMINATION

THE UNIVERSITY OF ZAMBIA  
SCHOOL OF NATURAL SCIENCES

2009 ACADEMIC YEAR SECOND SEMESTER  
FINAL EXAMINATIONS

C 312:                   BIOCHEMISTRY II

TIME:                   THREE HOURS

INSTRUCTIONS:

- i)     ANSWER ANY FIVE (5) QUESTIONS
  - ii)    MAKE SURE YOU HAVE THREE (3) PRINTED PAGES
- 

QUESTION 1

- a) *E. coli* DNA polymerase I is a complex enzyme. Briefly **describe** TWO of its activities and briefly **explain** their roles in DNA synthesis.
- b) **Why** is a short RNA primer needed for DNA replication? Briefly **explain**.
- c) Using the genetic code provided (Figure 1) **determine** the amino acid sequence of the following nucleotide. Assume the reading frame is shifted 2 bases to the right.

AATGGTAGGATTCCCCCGTGGATTCC

[20 MARKS]

QUESTION 2

- a) **Draw** a neat and well labeled diagram showing the gene structure in the *lac operon*.
- b) Briefly **explain** how *E. coli* represses the expression of the structure in a) above.
- c) **What** is the function of catabolite activator protein (CAP) and **how** does it work?

[20 MARKS]

### QUESTION 3

Cancer patients can be given cytotoxic (cell-killing) agents like FdUMP, a fluorine containing analogue of UMP and methotrexate to treat the disease. Unfortunately, these drugs cause patients to temporarily go bald.

- a) **Show** by means of structures and reactions how these agents serve as cancer therapeutic agents.
- b) **Briefly explain** why these patients go bald.

[20 MARKS]

### QUESTION 4

Excretion of nitrogen is one of the key functions of the liver. **Describe** how this process is carried out in man and **explain** how it is linked to the metabolism of proteins.

[20 MARKS]

### QUESTION 5

**Describe** the degradation of a fatty acid with the structure  $17:2^{\Delta 9,12}$  and **explain** how much energy is produced in the form of ATP.

[20 MARKS]

### QUESTION 6

**Describe** the formation of glucose in C4 plants, clearly explaining the role of the products of the light-dependent reactions.

[20 MARKS]

---

END OF EXAMINATION

		Second letter				
		U	C	A	G	
U	UUU } Phe	UCU } Ser	UAU } Tyr	UGU } Cys	U C A G	
	UUC } Leu	UCC } Ser	UAC } Tyr	UGC } Cys		
	UUA } Leu	UCA } Ser	UAA Stop	UGA Stop		
	UUG } Leu	UCG } Ser	UAG Stop	UGG Trp		
C	CUU } Leu	CCU } Pro	CAU } His	CGU } Arg	U C A G	
	CUC } Leu	CCC } Pro	CAC } His	CGC } Arg		
	CUA } Leu	CCA } Pro	CAA } Gln	CGA } Arg		
	CUG } Leu	CCG } Pro	CAG } Gln	CGG } Arg		
A	AUU } Ile	ACU } Thr	AAU } Asn	AGU } Ser	U C A G	
	AUC } Ile	ACC } Thr	AAC } Asn	AGC } Ser		
	AUA } Ile	ACA } Thr	AAA } Lys	AGA } Arg		
	AUG Met	ACG } Thr	AAG } Lys	AGG } Arg		
G	GUU } Val	GCU } Ala	GAU } Asp	GGU } Gly	U C A G	
	GUC } Val	GCC } Ala	GAC } Asp	GGC } Gly		
	GUA } Val	GCA } Ala	GAA } Glu	GGA } Gly		
	GUG } Val	GCG } Ala	GAG } Glu	GGG } Gly		

Figure 1 Genetic code

**THE UNIVERSITY OF ZAMBIA  
SCHOOL OF NATURAL SCIENCES**

**2009 ACADEMIC YEAR SECOND SEMESTER  
FINAL EXAMINATIONS**

**C342: INORGANIC CHEMISTRY III**

**TIME: THREE HOURS**

**INSTRUCTIONS: ANSWER ANY FOUR QUESTIONS**

---

Question 1. (a) The Irving-William series summarizes the variation in thermodynamic stability of complexes with the change in the central metal ion. Explain.

(b) The formation of a cadmium complex with  $\text{Br}^-$  from a hexa aqua complex exhibits the stability constants  $K_1 = 1.56$ ,  $K_2 = 0.54$ ,  $K_3 = 0.06$ ,  $K_4 = 0.37$ . Suggest an explanation of why  $K_4$  is larger than  $K_3$ .

(c) When CO becomes co-ordinated to  $\text{BH}_3$  its stretching frequency increases, but when CO becomes co-ordinated to  $\text{Ni}(\text{CO})_3$  its stretching frequency decreases. Explain.

Question 2. (a) Predict the geometries of complexes, which result from the following reactions

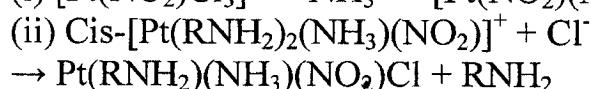
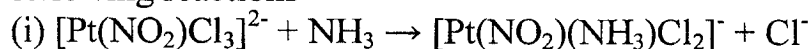

(b) The reaction of  $\text{CrCl}_3$  with liquid  $\text{NH}_3$  gives principally  $[\text{Cr}(\text{NH}_3)_5\text{Cl}]\text{Cl}_2$ , but when a trace of  $\text{KNH}_2$  is present, the main product is  $[\text{Cr}(\text{NH}_3)_6]\text{Cl}_3$ . Explain.

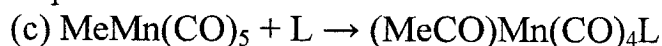

What are the possible mechanisms for the above reaction.

Question 3. (a) Show that the following compounds obey the effective atomic rule [EAN]

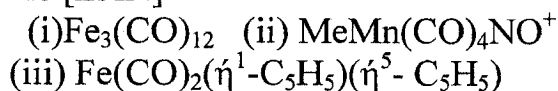

(b) Determine the M-M bond order consistent with the 18 electron rule for the following.:

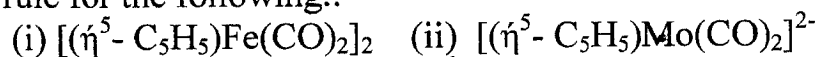

(c) Identify the most likely 2<sup>nd</sup> row transition metal for each of the following.

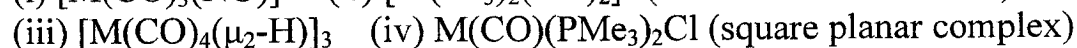
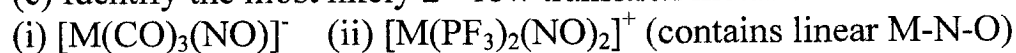

Question 4. (a) Based on observed value of magnetic moment what should be the number of unpaired electrons in  $\text{Pr}^{3+}$  ion. ( $\text{Pr}^{3+}$  magnetic moment = 3.6 BM). How can you account for any anomaly if present? Write its ground state electronic configuration.

(b) Mention some important features of lanthanide  $\beta$ -diketones.

(c) (i) What is the product obtained by dissolution of  $\text{U}_3\text{O}_8$  in  $\text{HNO}_3$ ?

(ii) How would you attempt the following conversion?

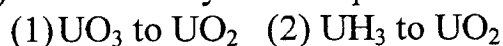

Question 5. (a) What is the binding energy of  ${}_{26}\text{Fe}^{56}$  expressed in MeV? Masses of proton, neutron, and iron are 1.008, 1.009 and 55.934 amu respectively. Where is this on the binding energy versus mass number curve? Why don't we have to worry about an enemy that claims they have developed the iron bomb?

(b) A sample of Uranium mineral was found to contain 0.214 gm of Lead-206 for every gram of uranium. Calculate the time when the mineral was formed in the earth's crust. The  $t^{1/2}$  of U-238 is  $4.5 \times 10^9$  years.

(c) Lead 208 is known and stable. What is the reason behind the non-existence of lead 164?

Question 6. (a) Write down the reactions, indicating temperature, pressure and catalysts for production of liquid non-aqueous solvents: Ammonia, Sulphuric acid and Sulphur dioxide.

(b) Describe some useful non-aqueous solvents.

(c) Write balanced decomposition and chemical reactions of non-aqueous Sulphuric acid with  $\text{HNO}_3$ ,  $(\text{NO}+\text{NO}_2)$ ,  $\text{HClO}_4$ ,  $\text{PCl}_5$  and  $\text{SO}_3$ .

END OF EXAMINATION

---

# PERIODIC TABLE OF THE ELEMENTS

## KEY

Atomic number  
**X**  
Atomic mass  
Name of the  
element X

1	2	3	4	5	6	7	8	9	10	11	12	13	14	15	16	17	18
1 H 1.01 Hydrogen	2 He 4.00 Helium															9 F 19.00 Fluorine	10 Ne 20.18 Neon
3 Li 6.94 Lithium	4 Be 9.01 Beryllium											5 B 10.81 Boron	6 C 12.01 Carbon	7 N 14.01 Nitrogen	8 O 16.00 Oxygen	17 Cl 35.45 Chlorine	18 Ar 39.95 Argon
11 Na 23.00 Sodium	12 Mg 24.31 Magnesium											13 Al 27.99 Aluminum	14 Si 28.09 Silicon	15 P 30.99 Phosphorus	16 S 32.07 Sulfur	35 Br 79.90 Bromine	36 Kr 83.80 Krypton
19 K 39.10 Potassium	20 Ca 40.08 Calcium	21 Sc 44.96 Scandium	22 Ti 47.88 Titanium	23 V 50.94 Vanadium	24 Cr 52.00 Chromium	25 Mn 54.94 Manganese	26 Fe 55.85 Iron	27 Co 58.93 Cobalt	28 Ni 58.69 Nickel	29 Cu 63.65 Copper	30 Zn 65.39 Zinc	31 Ga 69.72 Gallium	32 Ge 71.61 Germanium	33 As 74.92 Arsenic	34 Se 78.96 Selenium	53 I 126.90 Iodine	54 Xe 131.2 Xenon
37 Rb 85.47 Rubidium	38 Sr 87.62 Strontium	39 Y 88.91 Yttrium	40 Zr 91.22 Zirconium	41 Nb 92.91 Niobium	42 Mo 95.94 Molybdenum	43 Tc 97.91 Technetium	44 Ru 101.07 Ruthenium	45 Rh 102.91 Rhodium	46 Pd 106.42 Palladium	47 Ag 107.87 Silver	48 Cd 112.41 Cadmium	49 In 114.82 Indium	50 Sn 118.71 Tin	51 Sb 121.76 Antimony	52 Te 127.60 Tellurium	85 At 209.99 Astatine	86 Rn 222.0 Radon
55 Cs 132.91 Cesium	56 Ba 137.33 Barium	57-71 89-103 Lanthanum Cerium Praseodymium Neodymium Promethium Samarium Europium Gadolinium Terbium Dysprosium Holmium Erbium Thulium Ytterbium Lutetium	72 Hf 178.49 Hafnium	73 Ta 180.95 Tantalum	74 W 183.84 Tungsten	75 Re 186.21 Rhenium	76 Os 190.23 Osmium	77 Ir 192.22 Iridium	78 Pt 195.08 Platinum	79 Au 196.97 Gold	80 Hg 200.59 Mercury	81 Tl 204.38 Thallium	82 Pb 207.2 Lead	83 Bi 208.98 Bismuth	84 Po 208.98 Polonium	209.99 Astatine	222.0 Radon
87 Fr 223.02 Francium	88 Ra 226.03 Radium																



**The University of Zambia**  
**School of Natural Science**  
Department of Computer Studies

**FINAL EXAM SEMESTER II – April 2009**

**Fundamentals of Computer Architecture (CST 2032)**

---

---

**Instructions**

1. There are two sections, A and B and a total of six questions in this question paper.
2. Section A has two questions while section B has four questions
3. You are required to answer a total of five questions only
4. Each question carries 20 marks
5. Answer all questions in section A and any three questions in section B
6. Usage of Calculators is not allowed in this Examination

**Date: Thursday 30<sup>th</sup> April 2009**

**Time: 09:00hrs – 12:00hrs**

**Venue: Upper Dining Hall**

**NOTE: Do not open this paper until you are told to do so**

---



---

## SECTION A – Answer all the questions in this section

---



---

### 1) QUESTION ONE

- a) Define the following terms [2 Marks]
- Computer Architecture
  - Truth Table
- a) Give two reasons why it is important to study Computer Architecture. [2 Marks]
- b) List the **four** basic functions of a computer, then **draw** a well labelled diagram showing a functional view of the computer. [3 Marks]
- c) Sketch a diagram showing *Booth's Algorithm for Two's Complement Division*. Using Booth's Algorithm, perform the following calculations using 8 bits only and Twos Complements representation. Comment on your answer. If there is an overflow expand the number of bits to 16 bits and give the collect answer. [8Marks]

i)  $-17 \times 24 =$

ii)  $-87 \div 4 =$

- d) Draw the diagram that represents the expression below. Find the value of F if A=0, B=1, C=0, D=1 and E=1 [5 Marks]

i)  $F = C(\overline{B + A})D + \overline{E}$

ii)  $F = D(\overline{A + B})C$

**2) QUESTION TWO**

- a) Define the following terms [2 Marks]
- Nibble
  - Word
- b) Draw the diagrams for the following [2 Marks]
- OR Gate
  - NOT Gate
  - AND Gate
  - NAND Gate
- e) Give the general formula for the [4]
- Twos Complements Representation
  - Signed Magnitude Representation
- c) Draw a well labelled diagram showing the **Top – Level Structure** of the computer [2 Marks]
- d) Perform the following arithmetic using IEEE 32-bit floating point format. [10 Marks]

i)  $112.234 - 23.971 =$

ii)  $57.78 \times 18.021 =$

---



---

**Section B – Answer any three questions in this section**

---



---

**3) QUESTION THREE**

- a) Sketch a diagram of the *Static RAM (SRAM) Cell*. [3 Marks]
- b) Perform the following arithmetic conversion from [8 Marks]
- i) Base ten to base two
    - (1) 25
    - (2) 491
  - ii) Base sixteen to base two
    - (1) ABC5
    - (2) ACD
  - iii) Decimal digits to the IEEE – 32 bit floating point representation
    - (1) -25.31
    - (2) 9.241
- c) Simplify the following Logic Circuits completely. Then find the value of Z if A=1, B=1, C=0, D=1 and E =1 [9 Marks]

i)  $Z = \overline{AB} + C(\overline{B + A})D + E$

ii)  $Z = C(\overline{B + A})D + E + \overline{BC}$

iii)  $Z = \overline{(B + D + C + A)}$

---



---

**4) QUESTION FOUR**

- a) Express the following numbers in IEEE 32-bit floating point format [6 Marks]
- i) +23.32
  - ii) 171.765
- b) Represent the number  $-179_{ten}$  using either eight or sixteen bits into [3 Marks]
- i) Ones complement
  - ii) Twos complement
  - iii) Signed magnitude

- c) Although a variety of different bus implementation exists, there are a few basic parameters or design elements that serve to classify and differentiate buses. **List** the five elements of the Bus Design and **discuss** each one of them. [5 Marks]
- d) The diagrams show the Boolean logics. **Come up** with the *Boolean expression* for the diagram below. **What** will be the value of Z if A=0, B=1 and C=1 D=1, E= 0 [6 Marks]

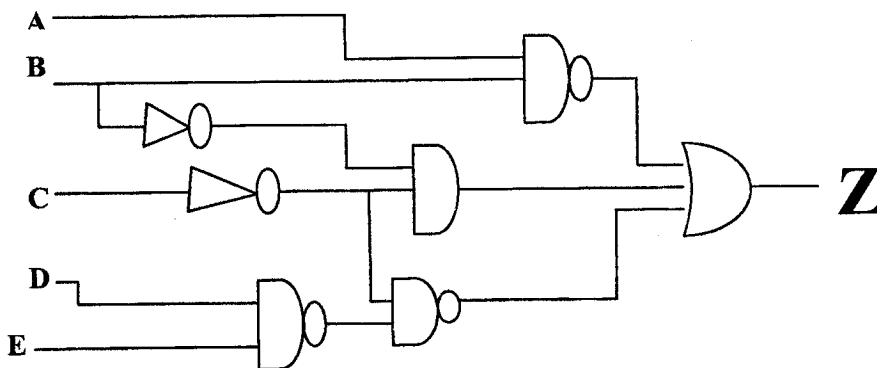
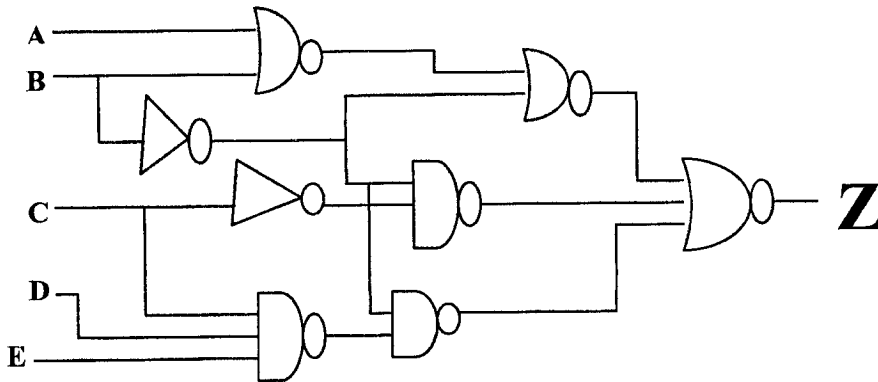

### 5) QUESTION FIVE

- a) Although there is a large number cache implementation, there are a few basic design elements that serve to classify and differentiate cache architectures. **List** the **six elements** of **Cache Design** and where possible **give two examples** of each. [6 Marks]
- b) **List** the **eight** key characteristics of computer memory system. Give an example for each characteristic. [4 Marks]

- c) The basic function performed by a computer is execution of a program, which consists of a set of instructions stored in memory. The processor fetches the instructions from memory one at a time and executes each instruction. *Sketch* a well labelled diagram showing the **Basic Instruction Cycle**. [2 Marks]
- d) **Draw a well labelled diagram** showing the structure of the IAS Computer proposed by John Von Neumann. Give the function of each component. [6 Marks]
- e) **Give two reasons** why a DVD stores more information than a CD [2 Marks]
- 
- 

## 6) QUESTION SIX

- a) **Give two advantages** and **two disadvantages** of using Assembly language as compared to; [8 Marks]
- High level languages such as Java and C++
  - Machine language
- b) The Computer System's I/O architecture is its interface to the outside world. This architecture provides a systematic means of controlling interaction with the outside world and provides the operating system with the information it needs to manage I/O activity effectively. [6 Marks]
- Draw and label a diagram** showing the *Generic Model of an I/O Module*.
  - List the five major functions** or requirements of the I/O module.
- c) **Give the basic structure and how data is stored** on the following external Memory [6 Marks]
- Magnetic Disk (HDD)
  - Magnetic Tape
  - CD and DVD

**END OF EXAMINATION PAPER**

**THE UNIVERSITY OF ZAMBIA**  
**DEPARTMENT OF COMPUTER STUDIES**  
**CST3032 – ARTIFICIAL INTELLIGENCE FUNDAMENTALS**

**UNIVERSITY EXAMINATION**

Thursday, 23<sup>rd</sup> April 2009

---

**INSTRUCTIONS:** There are **SIX (6)** questions in this examination and you are required to answer **ONLY FIVE (5)** of them in any order. All questions have the same weight. **Question ONE (1) is COMPULSORY. PLEASE KEEP YOUR ANSWERS AS PRECISE AND CONCISE AS POSSIBLE. GOOD LUCK!**

**DURATION:** 3 Hours

---

1.
  - a. Define the following terms
    - i. Agent
    - ii. Rational agent
    - iii. Agent function
    - iv. Agent program
  - b. List the four basic kinds of agent programs that embody the principles underlying almost all intelligent systems
  - c. Given the following well-formed formulas, formally show that  $S \vee R$  follows. Do not generate more than 10 more formulas before concluding.
    - i.  $\neg(\neg Q) \wedge Z$
    - ii.  $\neg W$
    - iii.  $(\neg W \wedge Q) \Rightarrow \neg P$
    - iv.  $Q \Rightarrow (S \vee P)$
    - v.  $(P \wedge Q) \Rightarrow R$

- d. For each of the following develop
- A PEAS description and
  - Properties (Fully observable, Deterministic, Static, Discrete) Of the task environment
- i. Automated cab driver
- ii. Intelligent medical diagnosis machine

2.

- a. What are the four components used for formulating a problem as search
- b. What are the four components that are usually employed in measuring the performance of a search algorithm?
- c. Consider the following scenario:

Three missionaries and three cannibals are on one side of a river, along with a boat that can hold up to a maximum of two people. These people have to cross to the other side of the river in such a way that at no time should the cannibals outnumber the missionaries in one place because the cannibals might eat the missionaries.

- i. Formulate this as a search problem
- ii. Come up with a heuristic function  $h(n)$  that can be used in guiding the search for this problem?[hint: think of the number of people to be on the other side of the river]
- iii. What is  $h(\text{start-state})$  where start-state is defined in your formulation above.
- iv. Show that your heuristic is 0 for the goal state.
- v. Draw the search tree returned by greedy best-first search and show the order in which these people cross the river. Do not return to parent node.

3.

- a. Define the following terms
- i. Admissible heuristic
  - ii. Consistent heuristic
  - iii. Best-first search
  - iv. Local search
- b. Consider the following map (not drawn to scale).

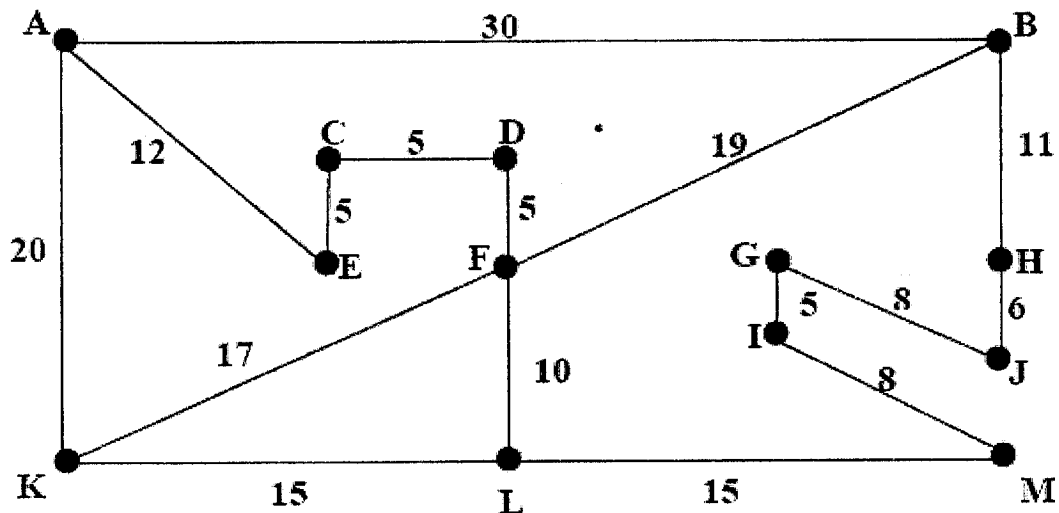

You are to work out a route from town A to town M. You should not re-visit a town that you have already passed through.

- $G(n)$  = The cost of each move as the distance between each town (shown on map).
- $H(n)$  = The heuristic for each town. These distances are given in the table below

A	56	E	29	I	8		
B	22	F	30	J	5		
C	30	G	14	K	30		
D	29	H	10	L	15	M	0.00

- i. Is the heuristic admissible?
- ii. Use the A\* algorithm to work out a route from town A to town M. Provide the search tree for your solution, showing the
  1. order in which the nodes were expanded and the
  2. cost at each node.
- iii. State the route you would take and the cost of that route.
- iv. What is the cost of that route?

4.

- a. Define the following as applied to propositional logic agents,
  - i. Entailment
  - ii. Model of a sentence
  - iii. Sound inference rule.
  - iv. Unsatisfiable sentence

- b. How is entailment related to model of a sentence
- c. How is unsatisfiability relate to inference rules
- d. Hence show that the Modus Ponens inference rule is sound
- e. Consider the following:

If it is raining then it is hot and humid. If it is not raining or just hot, then it is not wet. It is wet if it is dumpy.

- i. Describe a set of propositional letters which can be used to represent the knowledge base.
- ii. Translate the KB into propositional logic using your propositional letters from part a.
- iii. Is it Dumpy? Answer this question by using logical inference rules with the KB

5.

- a. Consider the search space below, where  $S$  is the start node and  $G1$  and  $G2$  satisfy the goal test. Arcs are labeled with the cost of traversing them and the estimated cost to a goal is reported inside nodes. Arrows indicate unidirectional navigation For each of the following search strategies, indicate which goal state is reached (if any) and list, *in order*,

- all the states *popped off of the FRINGE list*. When all else is equal, nodes should be removed from OPEN in alphabetical order.
- The path returned
- The cost of the path returned

- i. Uniform Cost
- ii. Beam (with beam width = 2 and using)

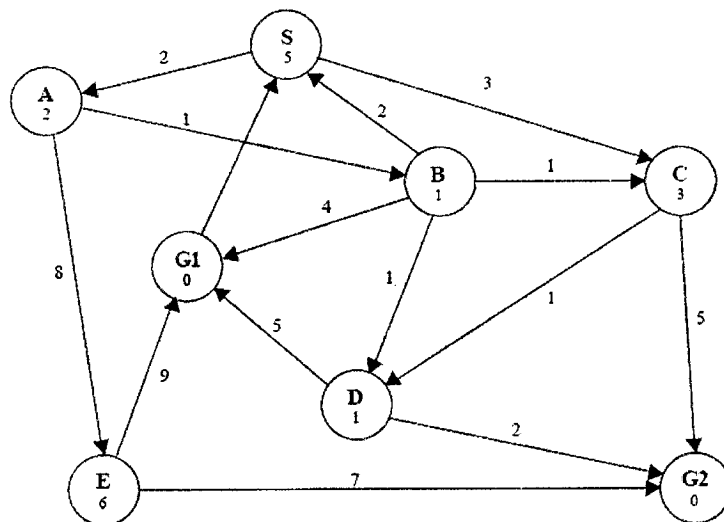

b. Shown below is the game tree where the root node is the MAX node

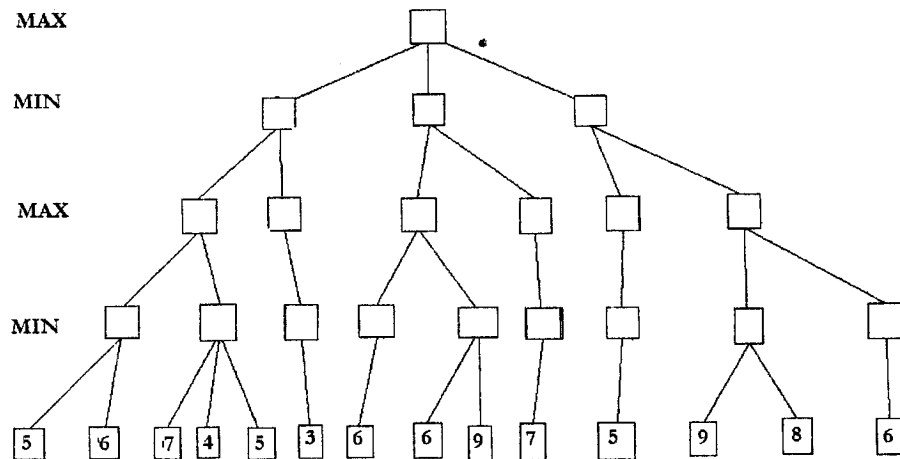

Assume that:

- the tree is explored by minimax (and alpha-beta pruning) in a left to right manner
- the numbers beneath the leaves of the tree are the evaluation function values for the corresponding states
  - i. Write in the boxes the minimax values for each state. Indicate the move chosen by MAX(the computer) as its first move and the branches that are pruned.

6.

- a. Explain the following terms as applied to constraint satisfaction problems
  - i. Forward checking
  - ii. Constraint propagation
  - iii. Complex constraint
  - iv. Constraint graph
- b. Briefly describe the three heuristics that are used in the variable and value assignment order used in CSPs. For each heuristic, state the purpose and how variables or values are identified in the process of assignment.
- c. Mrs. Green has just finished partitioning her flower garden into sections A to E according to the diagram below. She intends to plant her flowers. Currently she has seeds for the red flowers, blue flowers, and purple flowers. She wants each partition to have distinct coloured flowers from those in the adjacent sections. She has plenty seeds of red flowers and very limited quantities of purple flowers. Naturally she wants to use as much of the seeds of red flowers as possible, followed by the blue ones. The largest portion E cannot be assigned the purple flowers for fear that it might be too big for the available seeds of the purple flowers. You have been hired help Mrs. Green to come up with colouring scheme for her garden.

- i. Formulate this as a Constraint Satisfaction Problem.
- ii. Draw a constraint graph.
- iii. Show the order in which the partitions are assigned colours following the three heuristics outlined above. State assumptions you have taken in resolving ties not solved by the heuristics.

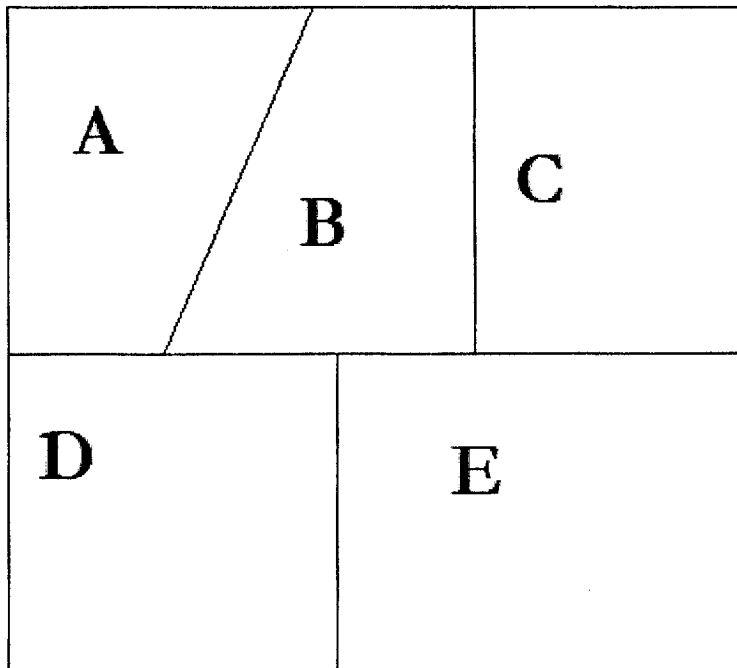

\*\*\*\*\*END OF EXAMINATION\*\*\*\*\*

# UNIVERSITY OF ZAMBIA

School of Natural Sciences

Department of Computer Studies

CS4012 Final Exam

---

## Advanced Operating and Distributed Systems

**Time 3 Hours**

**4/28/2009**

This exam has two sections. Answer all questions from section A. Each question in Section A carries 4 points. Answer any three questions from Section B. Each question in Section B carries 20 points.

## Section A

1. Two real-time processes are running on a computer. The first one runs every 25 msec for 10 msec. The second one runs every 40 msec for 15 msec. Will RMS always work for them?
2. Computing has for a long time been CPU-centric. One of the attempts to change this is Sun Microsystems Jini. What is Jini? State the four methods that are defined on the Javaspaces that is used by Jini clients and services for communication.
3. Most computer science multi-media technology is driven by the entertainment industry. Audio music samples are usually 16 bits in size and sampled on two channels. A Compact Disc holds 74 min of music or 650 MB of data. Make an estimate of the compression factor used for music. Sensational Zambia artists, Petersen and Shy-man shy-izo, propose a double compression factor so that Audio CDs can have more tracks. How will this affect storing data on Compact Discs?
4. Consider the following way to encrypt a file. The encryption algorithm uses two  $n$ -byte arrays,  $A$  and  $B$ . The first  $n$  bytes are read from the file into  $A$ . Then  $A[0]$  is copied to  $B[i]$ ,  $A[1]$  is copied to  $B[j]$ ,  $A[2]$  is copied to  $B[k]$ , etc. After all  $n$  bytes are copied to the  $B$  array, that array is written to the output file and  $n$  more bytes are read into  $A$ . This procedure continues until the entire file has been encrypted. Note that here encryption is not being done by replacing characters with other ones, but by changing their order. How many keys have to be tried to exhaustively search the key space? Give an advantage of this scheme over a mono-alphabetic substitution cipher?
5. Self-extracting archives, which contain one or more compressed files packaged with an extraction program, are frequently used to deliver programs or program updates. Briefly discuss the security implications of this technique.
6. As Internet cafes become more widespread, people are going to want ways of going to one anywhere in the world and conducting business from them. Describe a way to produce signed documents from one using a smart card (assume that all the computers are equipped with smart card readers). Is your scheme secure?

7. When the TSL instruction is used for multiprocessor synchronization, the cache block containing the mutex will get shuttled back and forth between the CPU holding the lock and the CPU requesting it if both of them keep touching the block. To reduce bus traffic, the requesting CPU executes one TSL every 50 bus cycles, but the CPU holding the lock always touches the cache block between TSL instructions. If a cache block consists of 16 32-bit words, each of which requires one bus cycle to transfer, and the bus runs at 400 MHz, what fraction of the bus bandwidth is eaten up by moving the cache block back and forth?
8. A 14-GB disk with 1000 cylinders is used to hold 1000 30-sec MPEG-2 video clips running at 4 Mbps. They are stored according to the organ-pipe algorithm. Assuming Zip's law, what fraction of the time will the disk arm spend in the middle 10 cylinders?
9. How must the implementation of send and receive differ between a shared memory multiprocessor system and a multicomputer, and how does this affect performance?
10. Can uncompressed black-and-white NTSC television be sent over fast Ethernet? If so, how many channels at once?

## Section B

1.

- a) Consider a secret-key cipher that has a  $26 \times 26$  matrix with the columns headed by  $ABC \dots Z$  and the rows are also  $ABC \dots Z$ . Plaintext is encrypted two characters at a time. The first character is the column; the second is the row. The cell formed by the intersection of the row and column contains two ciphertext characters. What constraint must the matrix adhere to and how many keys are there? **[10 points]**
- b) Give a simple example of a mathematical function that to a first approximation will do as a one-way function. Elaborate. **[10 points]**

2. Operating Systems design has been highly affected by a new paradigm of applications known as multi-media applications. Operating system design has had to evolve to support multimedia.

- a) Give an example multimedia in use? What two characteristics of multimedia are fundamental when considering Operating System design? [5 points]
- b) What is video on demand and near video on demand? [5 points]
- c) Outline the steps involved in encoding an image with JPEG. [5 points]
- d) Three periodic processes, each displaying a movie are running. The frame rates and processing requirements per frame are different for each movie. Suppose that each of the three processes is accompanied by a process that supports an audio stream running with the same period as its video process, so audio buffers can be updated between video frames and that all three of these audio processes are identical. How much CPU time is available for each burst of an audio process? [5 points]

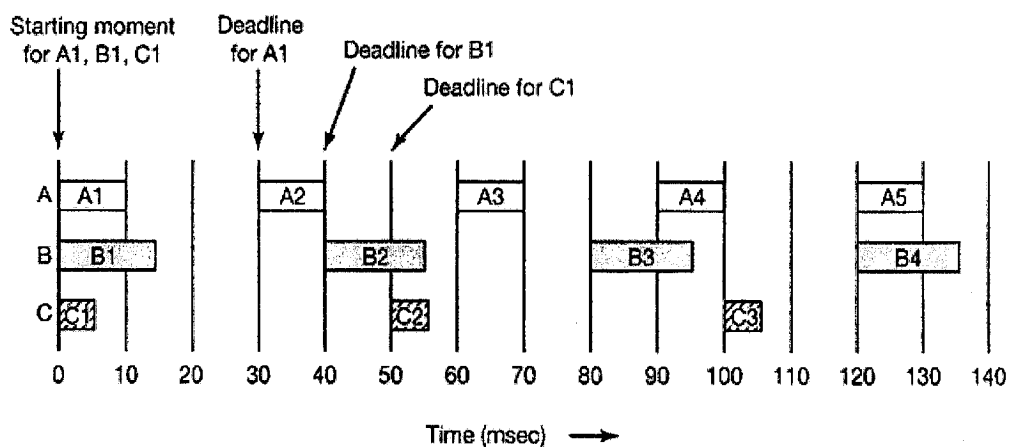

3.

- a) Briefly outline the two file organization strategies that can be used with non-contiguous movie storage. [5 points]
- b) What are the conditions that processes must meet in order for the RMS algorithm to apply on them? [5 points]
- c) What is Zipf's law? How does it relate to the pipe organ algorithm? [5 points]
- d) The CPU of a video server has a utilization of 65%. How many movies can it show using RMS scheduling? [5 points]

4.

- a) If a CPU issues one memory request with every instruction and the computer runs at 200 MIPS, about how many CPUs will it take to saturate a 400-MHz bus? Assume that a memory reference requires one bus cycle. Now repeat

this problem for a system in which caching is used and the caches have a 90% hit rate. Finally, what cache hit rate would be needed to allow 32 CPUs to share the bus without overloading it? [10 points]

- b) Briefly outline and explain the three organizations for multiCPU systems. [10 points]
5. One of the fundamental aspects of an operating system is its security. There are many techniques that are used to employ security in an Operating System.
- a) What is cryptography? [5 points]
  - b) Define a capability and access list. Compare and contrast the two. [5 points]
  - c) Define a mechanism - hardware and software - for authenticating users based on their finger prints. [5 points]
  - d) Protection mechanisms though necessary have an impact on system performance. Briefly outline how protection mechanisms impact system performance. [5 points]



# The University of Zambia

School of Natural Sciences

Computer Studies Department

---

<b>EXAM:</b>	<b>APRIL 2009 EXAM - SEMESTER TWO FINAL</b>
<b>COURSE:</b>	<b>CST4122 – FUNDAMENTALS OF COMPILERS</b>
<b>DURATION:</b>	<b>3 HOURS</b>
<b>VENUE:</b>	<b>NEW DINING HALL</b>

---

## INSTRUCTIONS

- *This paper contains seven (7) questions*
- **ANSWER A TOTAL OF FIVE QUESTIONS**
- *All questions carry equal marks (20 marks)*
- *Clearly number your answers*
- *Use the marks as a guide to the detail required in your answers while keeping your answers concise and relevant.*

**GOOD LUCK!!**

## QUESTION ONE

- a) What are the "front-end" and "back-end" components of a compiler? What distinguishes the "front-end" from the "back-end"? [6 marks]
- b) Given the following high level statement;  $position := initial + rate * 60$ , show the resulting transformations through the front-end phases of a compiler as discussed in class. Assume all identifiers are declared to be real numbers and 60 by itself is an integer. [14 marks]
- 

## QUESTION TWO

- a) Outline three roles of the lexical analyzer. [3 marks]
- b) A legal string begins with from 1 to 3 a's, is followed by 0 or more b's, c's, or d's, and ends with at least one e.
- Create a regular expression to accept legal strings (and only legal strings). [3 marks]
  - Create a nondeterministic finite state machine to accept legal strings (and only legal strings), USE THOMPSONS ALGORITHM. [7 marks]
- c) Minimize the following DFA [7 marks]

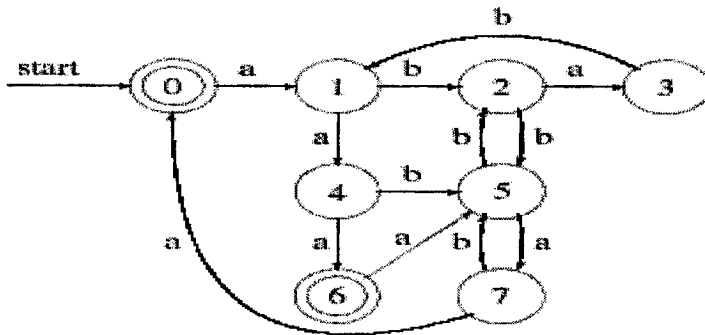

### QUESTION THREE

a) Outline three roles of the Parser. [3 marks]

b) Consider the following grammar:

$$\begin{aligned} E \rightarrow & \text{id} \mid \\ & ! E \mid \\ & E \&\& E \mid \\ & ( E ) \end{aligned}$$

where id, !, &&, (, and ) are terminals.

i. Prove that the grammar is ambiguous by finding a string and showing its two different syntax trees. [6 marks]

ii. Eliminate left-recursion from the grammar. [4 marks]

c) Consider the following First and Follow sets:

$$\text{First}(S) = \{b, \epsilon\}$$
$$\text{First}(T) = \{b, \epsilon\}$$
$$\text{Follow}(S) = \{a, \$\}$$
$$\text{Follow}(T) = \{a, b, \$\}$$

Give the simplest grammar (fewest productions and shortest right-hand sides) that produces these sets. As usual, S is the start symbol. [7 marks]

---

### QUESTION FOUR

[20 marks]

a) Consider the resulting NFA from question 2(b.ii) above,

i. Convert the NFA to a DFA, show the DFA transition table and the resulting DFA diagram.

ii. Show the sequence of moves made by the DFA in processing the following input strings; aee, aaabcde

## QUESTION FIVE

[20 marks]

- a) Consider the following simple grammar for assignment statements with expressions involving addition or subtraction:
- 1)  $\text{stmt} \rightarrow \text{ID} \text{'=' expr}$
  - 2)  $\text{expr} \rightarrow \text{expr} \text{'+' NUM}$
  - 3)  $\text{expr} \rightarrow \text{expr} \text{'-' NUM}$
  - 4)  $\text{expr} \rightarrow \text{NUM}$
- i. Construct the transition diagram of a predictive parser from the grammar
  - ii. Write the parsing procedures in pseudo code
  - iii. Trace the parser for input;  $a:= 1 + 2 - 3$
- 

## QUESTION SIX

- a) Consider the following grammar with terminal symbols;  $a$   $b$   $+$ , non-terminal symbols  $S$ ,  $A$ ,  $B$  where  $S$  is the start symbol and productions
- (P1)  $S \rightarrow A + B$
  - (P2)  $S \rightarrow B$
  - (P3)  $A \rightarrow a A$
  - (P4)  $A \rightarrow \epsilon$
  - (P5)  $B \rightarrow b B$
  - (P6)  $B \rightarrow \epsilon$
- i. Compute FIRST and FOLLOW for this grammar. [4 marks]
  - ii. Consider the following LL(1) parsing table for a predictive table parser:

	a	b	+	\$
S	P1	P2	P1	
A	P3		P4	
B		P5		P6

where  $P_i$  refers to the  $i$ th production in the above grammar. Detail how the sentence  $a + b$  would be parsed with a predictive table parser using this table. For each step of the process give the parser action, input and stack state.

[4 marks]

- iii. Is the parsing table given in (c) the correct LL(1) predictive parsing table for this grammar? If not identify and correct the errors in the table.

[4 marks]

- b) The following grammar is clearly not LL(1),

$$A \rightarrow A + B \mid A - B \mid B$$

$$B \rightarrow C * B \mid C / B \mid C$$

$$C \rightarrow ( A ) \mid \text{int}$$

- i. Transform the grammar to make it LL(1)?

[2 marks]

- ii. Construct the parsing table for a predictive parser for this grammar

[6 marks]

---

## QUESTION SEVEN

- a) Consider the following grammar;

$$S \rightarrow A + B$$

$$S \rightarrow B$$

$$A \rightarrow a A$$

$$A \rightarrow \epsilon$$

$$B \rightarrow b B$$

$$B \rightarrow \epsilon$$

- i. Construct an SLR parsing table for this grammar.

[15 marks]

- ii. Show behaviour of parser on string  $a + b$ .

[5 marks]

***THE END***

---

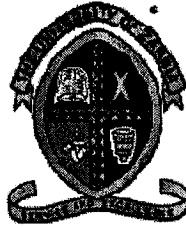

**The University of Zambia**  
**School of Natural Science**  
Department of Computer Studies

**FINAL EXAM SEMESTER II – April 2009**

**Computer Graphics (CST - 4132)**

---

---

**Instructions**

1. There are **two sections**, A and B and a total of **six questions** in this question paper.
2. **Section A** has **two questions** while **section B** has **four questions**
3. You are required to **answer a total of five questions only**
4. Each question carries **20 marks**
5. **Answer all** questions in **section A** and **any three** questions in **section B**

**Date: Wednesday 15<sup>th</sup> April 2009**

**Time: 09:00hrs – 12:00hrs**

**Venue: New Dining Hall**

**NOTE: Do not open this paper until you are told to do so**

---



---

**SECTION A – Answer all the questions in this section**

---



---

**1) QUESTION ONE**

- a) What is Computer Graphics? [1 Marks]
- b) Define the following terms [3 Marks]
- Dot Size
  - Pixel
  - Projection
- c) Give two reasons why it is very important to study Computer Graphics [2 Marks]
- d) Given the point of a rectangle as A (-2,-3), B (-8,-3), C (-8,-9) and D (-2,-9).  
Perform each of the following transformations on the above rectangle to compute the final coordinates and then sketch the final rectangle with the computed coordinates as A', B', C' and D' [10 Marks]
- Translation by T = (12,-9)
  - Rotation about the origin in the clockwise direction at 45°.
  - Scale in the Y direction by a scale factor of 4 and in the X direction by a scale factor of 2
  - Shear in the X direction by a shear factor of 3 and in the Y direction by a shear factor of 5

a) Let  $X = \begin{pmatrix} 1 & 4 & -2 \\ -5 & 3 & 2 \\ -1 & 1 & 2 \end{pmatrix}$  and  $Y = \begin{pmatrix} 7 & 2 & -11 \\ 9 & 7 & 3 \\ 6 & -3 & 1 \end{pmatrix}$ ; Compute the following [4 Marks]

- 8X
- 6Y
- Y x X

**2) QUESTION TWO**

a) Define the following terms [2 Marks]

- i) Hue
- ii) Cell Decomposition

b) Computer graphics is used today in many areas of the Industry, business, government, education and entertainment. List four uses of Computer Graphics and give a very brief explanation of each usage. [6 Marks]

c) Let  $X = \begin{pmatrix} 2 & 3 & 5 \\ 7 & 4 & 6 \\ -1 & 1 & 2 \end{pmatrix}$  and  $Y = \begin{pmatrix} 1 & 4 & -2 \\ 5 & 2 & 3 \\ 6 & -3 & 1 \end{pmatrix}$ ; Compute the following [6 Marks]

- i)  $Y^T$
  - ii) The Inverse of Matrix Y
- d) Given the point  $W$  in three dimension as (6,-3,2) [6 Marks]
- i) Computer the coordinates of the final point  $W'$  if  $W$  is translated with a translation T (3,-1, 8) and then followed by a shear in the Y direction with a shear factor of 4
  - ii) Rotate the point  $W$  about the z-axis in the clockwise direction at  $45^\circ$  about the origin and then Scale it in the X direction with the scale factor 2

---

---

**Section B – Answer any three questions in this section**

---

---

**3) QUESTION THREE**

- a) The diagram below shows the computer monitor which uses a Cathode Ray Tube (CRT) display technology. With the help of a well labelled diagram, briefly describe how the CRT works. [4 Marks]

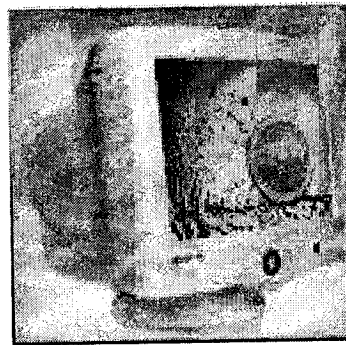

- b) Given the Vectors  $v = (6,2,)$  and  $u = (-7,4)$ ; Compute the following; [5 Marks]
- The angle between the vectors  $v$  and  $u$
  - The magnitude of  $\|v \cdot u\|$
- c) Given the vectors  $p=(-2,7,-4)$ ,  $q=(5,-3,6)$  and  $r = (1,-8,9)$ . Compute the Cross product of the three vectors [ 3 Marks]
- d) Input devices are an important component when coming up and during the usage of Computer Graphics Applications. Briefly explain how each of the following works [8]
- Data Tablet
  - Mouse
  - Trackball
  - Joystick

#### 4) QUESTION FOUR

- a) Using the diagram below show that;  $\mathbf{v} \cdot \mathbf{u} = \|\mathbf{v}\| \|\mathbf{u}\| \cos(\theta)$ ; [3 Marks]

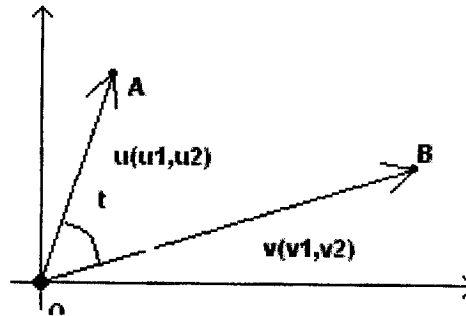

- b) Calculate the value of  $s\mathbf{v}$  and  $|s\mathbf{v}|$  when  $s = 3$ ,  $\mathbf{v} = (2, -3, 1)$ , where  $s$  is a scalar quantity and  $\mathbf{v}$  is a vector quantity [3 Marks]
- c) One of the most useful technologies in the field of computer graphics apart from display technologies is the Hard Copy Technologies. Examples of these technologies include Pen plotters, Laser printers, Film recorders, Thermal-transfer printers, Dot-matrix printers and Ink-jet Printers. **Briefly explain** how each of the following below works [6 Marks]
- Pen plotter** giving examples to *Flatbed Plotter* and *Drum Plotter*
  - Ink-jet Printer**
- d) The need to model objects as solids has resulted in the development of a variety of specialized ways to represent them in a field of Computer Graphics. Give a brief description for each of the following representation [8 Marks]
- Boundary Representation**
  - Constructive Solid Geometry**
  - Sweep Representation**
  - Spatial Partition Representation**

**5) QUESTION FIVE**

a) Define the following terms [3 Marks]

- i) Achromatic Light
- ii) Dynamic Range
- iii) Luminance

b) Give a brief description for each of the following Colour Models for raster graphics. [8 Marks]

- i) RGB Colour Model
- ii) CMY Colour Model
- iii) The YIQ Colour Model
- iv) The HSV Colour Model

b) With the aid of the diagrams, compare and contrast between the two types of Projections namely *Parallel* and *Perspective*[4 Marks]

c) Let  $A = \begin{pmatrix} 8 & 3 & 5 \\ 7 & 2 & 6 \\ -2 & 1 & 4 \end{pmatrix}$  and  $B = \begin{pmatrix} 9 & 4 & -2 \\ -6 & 5 & 8 \\ 7 & -3 & 1 \end{pmatrix}$ ; Solve the following [5 Marks]

- i)  $5A + B$
- ii)  $4B - 3A$
- iii) Determinant of A

**6) QUESTION SIX**

- a) With the help of a well labelled diagram, **give** a brief description on how each of the following display technologies works **[6 Marks]**
- i) Vector Graphics
  - ii) Raster Display
- b) Creation of the photo using a synthetic camera metaphor in 3D using 2D devices usually occurs through a series of steps. Name the steps required. **[3 Marks]**
- c) *Requicha* provides a list of properties desirable in **Solid Representation Modelling**. List all the six properties **[3 Marks]**
- d) Solve the following equations for x, y and z by using the inverse of the Matrix method. **[8 Marks]**
- $$x + 4y + 2z = 8$$
- $$2x - 6y + 3z = 12$$
- $$-3x + 9y - z = -6$$

**END OF EXAMINATION PAPER**

CANDIDATE'S COMPUTER NUMBER: .....

**THE UNIVERSITY OF ZAMBIA  
SCHOOL OF NATURAL SCIENCES**

**2009 ACADEMIC YEAR SECOND SEMESTER FINAL EXAMINATIONS**

**GEO 175: INTRODUCTION TO MAPPING TECHNIQUES IN GEOGRAPHY**

**PAPER 1: PRACTICAL  
AERIAL PHOTOGRAPHY, MAP READING, ANALYSIS AND INTERPRETATION**

**TIME:** Three Hours

**INSTRUCTIONS:** Answer all questions. The use of a Philip's University Atlas and an approved calculator is allowed. Candidates are encouraged to make use of illustrations wherever appropriate.

---

FOR USE BY EXAMINER

Question	Examiner's Mark	Moderator's Mark
Q1		
Q2		
Q3		
Q4		
Total		

**WARNING TO CANDIDATE: PLEASE READ ALL INSTRUCTIONS CAREFULLY BEFORE ATTEMPTING ANY QUESTION. FAILURE TO FOLLOW INSTRUCTIONS WILL RESULT IN AUTOMATIC DISQUALIFICATION**

***Answer all questions in the spaces provided on this question paper. In the case of calculations show all work.***

1. Write short explanatory notes and distinguish between the following:

(a) Elevation and Relief [5 Marks]

.....  
.....  
.....  
.....  
.....  
.....  
.....  
.....  
.....  
.....  
.....  
.....  
.....  
.....  
.....  
.....  
.....  
.....  
.....  
.....  
.....

(b) Contour interval and Vertical Rise [5 Marks]

.....  
.....  
.....  
.....  
.....  
.....  
.....  
.....  
.....  
.....  
.....  
.....  
.....  
.....  
.....  
.....  
.....  
.....  
.....  
.....  
.....



(e) Vertical and oblique aerial photographs [5 Marks]

.....

.....

.....

.....

.....

.....

.....

.....

.....

.....

.....

.....

.....

.....

.....

.....

.....

.....

.....

.....

.....

.....

.....

2. (a) Name any four useful clues in the identification of features on aerial photographs. [2 marks]

.....

.....

.....

.....

.....

.....

.....

(b) What are the two major sources of distortion on a vertical aerial photograph? [2 marks]

.....

.....

.....

.....

(c) What is the basic difference between low oblique and high oblique aerial photographs? [2 marks]

.....

.....

.....

.....

.....

.....

.....

(d) What do you understand by the term stereo pairs? [2 marks]

.....

.....

.....

.....

.....

.....

(e) What general term refers to the technology humans have developed that permit precision recording instruments that operate from high altitude vantage points providing a remarkable set of tools for the study of the earth. [2 marks]

.....

.....

.....

(f) An aerial photo survey is carried out at a mean height of 2,280 metres above the Victoria Falls. The camera used has a camera constant of 152 mm.

(i) What is the mean scale of the aerial photograph? [3 marks]

(ii) What is the scale at the foot of the Victoria Falls located at about 114 metres below the mean height of the terrain? [3 marks]

(iii) If the distance between the two ends of the Victoria Falls is 125 metres, what is the corresponding photo distance between the two points? [4 marks]

(iv) If the size of the photograph taken is 20 centimetre by 20 centimetres, what would be the ground area covered by the air photograph? [5 marks]

3. (a) Express two centimetres to a kilometre as a scale in figures. [3 marks]

(b) Express 1:10 000 as a scale in words. [3 marks]

(c) Draw a line scale in metric units for a map drawn on a scale of 1: 250,000 given that the maximum space available is 19 centimetres. [5 Marks]

(d) Calculate the length of a major unit for a map drawn on a scale of 1: 30 000.  
[3 Marks]

(e) If the vertical scale of a profile drawn from a topographical map on a scale of 1: 50 000 is exaggerated five times, what is the vertical scale? [3 Marks]

- (f) The distance between two points on a 1: 50 000 topographic map is 4 cm and the difference in height is 350 metres. Calculate the steepness of slope in degrees. [3 Marks]

4. (a) Using the contour method, draw an annotated diagram to show an escarpment with contours at a 20 metre vertical interval with a river flowing on the scarp slope with its source near the summit of the escarpment. [10 Marks]

(b) With the help of a diagram describe the following terms in a drainage basin and briefly comment on the conditions under which they form.

- (i) Insequent stream [2 Marks]
- (ii) Subsequent stream [2 Marks]
- (iii) Consequent stream [2 Marks]
- (v) Obsequent stream [2 Marks]
- (vi) Resequent stream [2 Marks]



**THE UNIVERSITY OF ZAMBIA  
SCHOOL OF NATURAL SCIENCES**

**2009 ACADEMIC YEAR SECOND SEMESTER FINAL EXAMINATIONS**

**GEO 175: INTRODUCTION TO MAPPING TECHNIQUES IN GEOGRAPHY**

**PAPER II: THEORY**

**CLASSIFICATION OF NUMERICAL DATA, CONSTRUCTION OF TABLES,  
STATISTICAL MAPS AND DIAGRAMS**

**TIME:** Three Hours

**INSTRUCTIONS:** Answer any four questions. Candidates are encouraged to make use of illustrations wherever appropriate.

1. The class marks of the first ten classes of a frequency distribution are 115, 124, 133, 142, 151, 160, 169, 178, 187 and 196.
  - (a) Calculate the class boundaries of the ten classes. [13 Marks]
  - (b) If the observations are recorded as correct to the nearest integer, what are the class limits of the ten classes? [12 Marks]
  
2. Study the data given in Table 1 and then answer the questions that follow.

**Table 1: Zambia's Population Distribution by Province in 2000**

Province	Size (Km <sup>2</sup> )	Population Size		Total
		Male	Female	
Central	94,394	489,436	517,330	1,006,766
Copperbelt	31,328	824,912	832,734	1,657,646
Eastern	69,106	642,433	658,540	1,300,973
Luapula	50,567	388,189	396,424	784,613
Lusaka	21,896	712,393	720,008	1,432,401
Northern	147,826	696,626	710,462	1,407,088
North Western	125,826	301,596	309,379	610,975
Southern	85,283	639,356	663,304	1,302,660
Western	126,386	375,950	406,559	782,509
<b>Total</b>	<b>752,612</b>	<b>5,070,891</b>	<b>5,214,740</b>	<b>10,285,631</b>

Source: GRZ (2001) *Preliminary Report for the 2000 Census of Population and Housing Count*, Lusaka, CSO, P4-5

- (a) Use the most appropriate statistical mapping technique to show the data in Table 1 on the outline map of Zambia (Figure 1) provided. [15 Marks]
- (b) What are the merits and demerits of the technique that you have used? [5 Marks]
- (c) What other information would you require if you were asked to construct a distribution of population map? [5 Marks]

3. Assume that you want to test the hypothesis that “the girls performance in schools where there are no boys around is better than in mixed schools” and you got hold of the information in Table 2a.

**Table 2a: Cambridge School Certificate Results for Geography, 1972**

Name and Type of High School	
Kabulonga High (Girls Only)	Kamwala High (Mixed- Results for Girls Only)
9F	9F
6P	7S
6P	8S
6P	6P
7S	9F
7S	9F
5P	9F
6P	6P
7S	7S
6P	9F
5P	9F
8S	8S
4P	7S
7S	8S
5P	9F
5P	9F
7S	8S
7S	8S
8S	9F
3P	8S
7S	9F
7S	9F
6P	7S
7S	8S
5P	6P
7S	7S
8S	9F
7S	8S
8S	8S
7S	9F

Source: Hypothetical

**Explanation for the Results**

The standard reached in the subject is shown by a numerical grade from 1-9 followed by the letters P, S, or F. Table 2b shows the meaning of these grades and letters in terms of school certificate standards.

**Table 2b: Meaning of Grades and Letters**

Grade & Letter	School Certificate Standard
1P & 2P	Distinction
3P & 4P	Merit
5P & 6P	Credit
7S & 8S	Subject Pass (Zambia Only)
9F	Fail

- (a) Select the relevant data from Tables 2a and 2b and show these in a table that will enable you to test the hypothesis. [15 Marks]
- (b) What conclusions can you draw from your table concerning the hypothesis? [10 Marks]

4. Examine the data given in Table 3 and then answer the questions that follow.

**Table 3: Population Distribution by age and sex, 1980**

Age Group	Population Size According to Sex (' 000)		Total
	Male	Female	
0 – 4	508	512	1,020
5 – 9	491	493	984
10 – 14	384	384	768
15 – 19	285	308	593
20 – 24	214	260	474
25 – 29	158	179	337
30 – 34	133	159	292
35 – 39	108	130	238
40 – 44	100	113	213
45 – 49	92	85	177
50 – 54	75	70	145
55 – 59	53	45	98
60 – 64	47	45	92
65 – 69	35	27	62
≥ 70	50	45	95
Not Stated	37	36	73
Total	2, 770	2, 891	5, 661

Source: GRZ (1986) *Country Profile: Zambia, 1985*, Lusaka, CSO, P3

- (a) Use the most appropriate statistical diagram to show the age and sex composition of the population using data in Table 3. [15 Marks]
- (b) What observation can you make from your diagram concerning the age and sex distribution of the population under study? [5 Marks]
- (c) What are the merits and demerits of the technique that you have employed in (a)?

5. The Central Statistical Office in 2001 produced a preliminary report of the 2000 Population Census which included data on the Population size of Lusaka Province by district shown in Table 4.

**Table 4: Population Size of Lusaka Province by District in 2000**

District	Population Size		Total
	Male	Female	
Chongwe	72,735	72,001	144,736
Kafue	83,421	78,841	162,262
Luangwa	10,686	11,304	21,990
Lusaka	545,551	557,862	1,103,413
Total	712,393	720,008	1,432,401

Source: GRZ (2001) *Preliminary Report for the 2000 Census of Population and Housing Count*, Lusaka, CSO, P9

- (a) Use the most suitable statistical diagram to show the data in Table 4. [15 Marks]
  - (b) What are the major highlights of your diagram? [5 Marks]
  - (c) What are the merits and demerits of the technique that you have used? [5 Marks]
6. Examine Figure 2 showing an island base map with spot heights and streams marked to help you. Remember that streams are found in the lowest parts of the valleys and that streams do not flow uphill.
- (a) Interpolate contours at 100 metre interval and label them. [15 Marks]
  - (b) What conclusions can you draw from your isopleths map? [5 Marks]
  - (c) What are the merits of the technique that you have used in (a)? [5 Marks]

---

**END OF EXAMINATION**

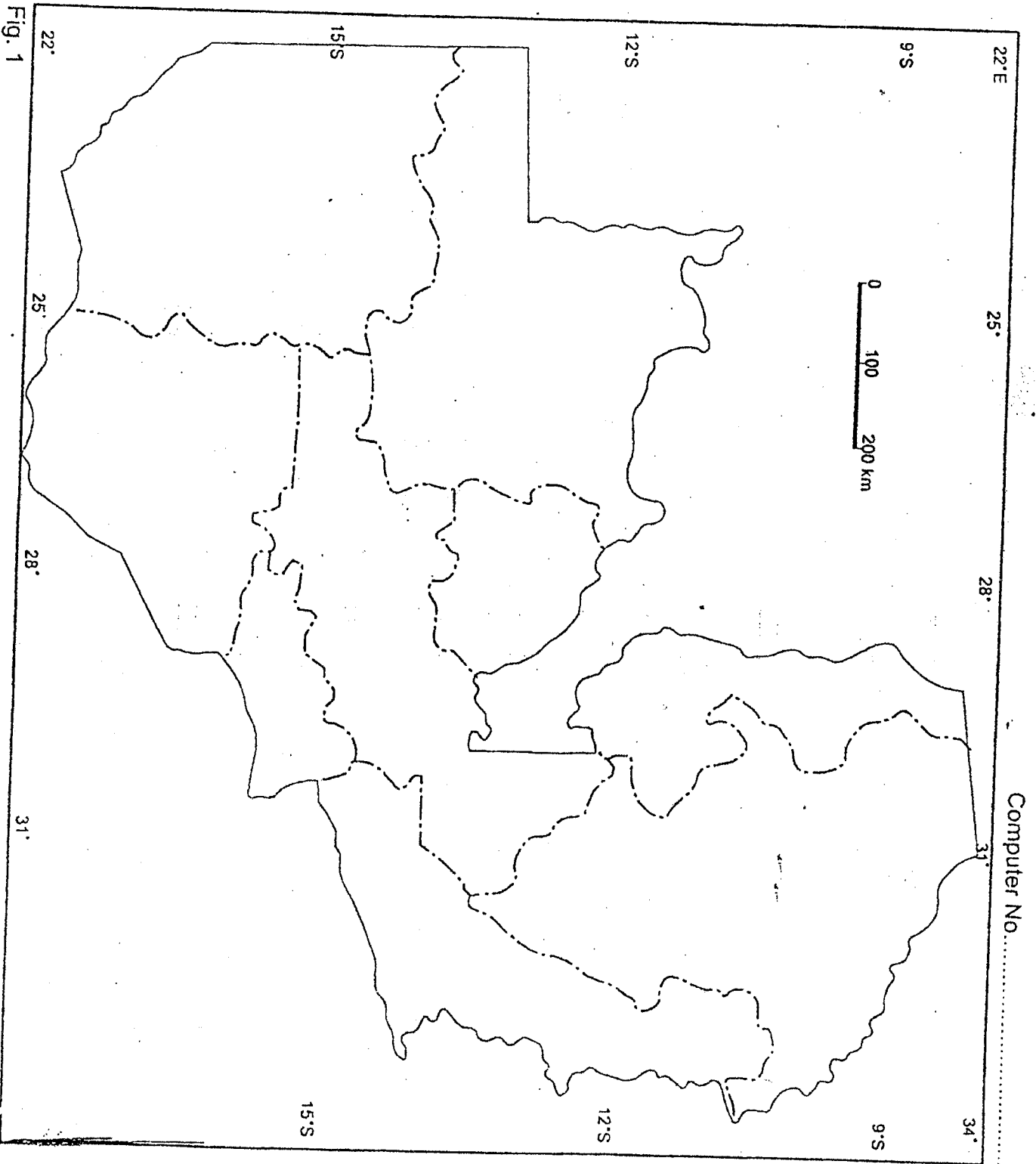
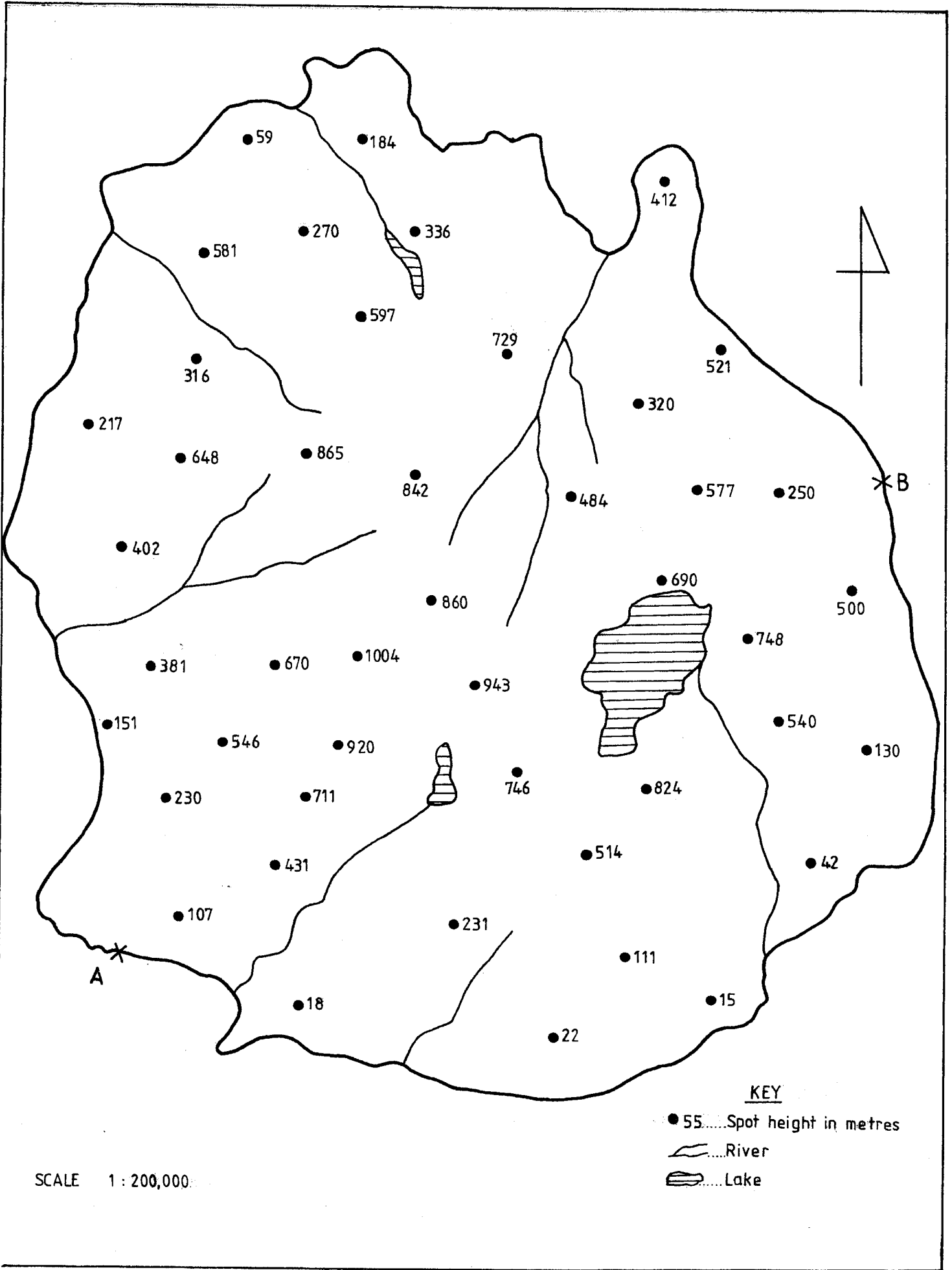

Fig. 1

Computer No.....

FIGURE 2



**THE UNIVERSITY OF ZAMBIA  
SCHOOL OF NATURAL SCIENCES**

**2009 ACADEMIC YEAR SECOND SEMESTER FINAL EXAMINATIONS**

**GEO 212: GEOGRAPHY OF ZAMBIA**

**TIME:**                    **Three hours**

**INSTRUCTIONS:** Answer any **four** questions.

All questions carry **equal marks**. Use of a Philips' University Atlas is allowed. Candidates are encouraged to use illustrations wherever appropriate.

---

1. Write short explanatory notes on **ALL** of the following.
    - a. Forest type of vegetation in Zambia,
    - b. Integrated Rural Development Programmes (IRDPs),
    - c. Two types of losses incurred by NAMBOARD during the Second Republic,
    - d. The five stages of Butler's life cycle theory,
    - e. The World Bank's five critical components of a rural development strategy.
  2. 'Zambia has abundant water resources which can be utilized for socio-economic development'. Discuss.
  3. 'The Rural Non-Farm Economy (RNFE) is a viable alternative for rural development in Zambia'. Discuss.
  4. Discuss the opportunities and challenges of Zambia's manufacturing industry in a liberalized economy.
  5. The emergence of Zambia as a nation suggests 'unity in diversity'. Discuss this statement in relation to pre-colonial migrations.
  6. Describe Zambia's agro-ecological regions and show their significance.
- 

**END OF EXAMINATION**

**THE UNIVERSITY OF ZAMBIA**  
**UNIVERSITY SECOND SEMESTER EXAMINATIONS**  
**APRIL 2009**

**LSE 322**  
**GEOGRAPHY TEACHING METHODS**  
**(SINGLE SUBJECT MAJOR)**

**TIME:** THREE (3) HOURS

**INSTRUCTIONS:** Answer **Question 1** and any **other two questions**. Illustrate your answers wherever possible.

- 
1. What is New Geography? What is 'new' in New Geography?
  2. Analyse Zambia's economy since independence, citing the factors that led to its rise and fall. State the measures the government has put in place to revive the economy since 1991.
  3. Discuss the national health programmes undertaken by the Zambian government and other stakeholders. Show how effective these measures have been.
  4. Explain the effects of socio-economic development on the quality of the environment.
  5. Analyse whether reproductive health issues should be left to individual citizens or to government policy.

**END OF EXAMINATION**

**THE UNIVERSITY OF ZAMBIA  
SCHOOL OF NATURAL SCIENCES**

**2009 ACADEMIC YEAR SECOND SEMESTER FINAL EXAMINATIONS**

**GEO 995: ENVIRONMENT AND NATURAL RESOURCES MANAGEMENT I**

Time: Three hours

Instructions: Answer any four questions. All questions carry equal marks. The use of approved electronic calculators is allowed.

1. For each of the following pairs of concepts, provide two distinctions.
  - a. Ecological density and crude density.
  - b. Physiological natality and ecological natality.
  - c. Biotic potential and environmental resistance.
  - d. Exponential population growth model and logistical growth model.
  - e. K-selected growth forms and r-selected growth forms.
  
2. Table 1 below, shows some hypothetical cohort data for an animal endemic to Zambia. A Consultant has advised the Zambia Wildlife Authority (ZAWA) to seek measures that would increase fecundity and population of this endemic animal. However, ZAWA has argued against the advice. You are required to analyse the data and answer the following questions. Answers to calculations must be correct to 3 decimal places.

Table 1. Cohort data for an animal endemic to Zambia

Age (Years)	Number of Individuals	Survivorship	Fecundity	Realised Fecundity
0	100	1.00	0.000	0
1	100	1.00	0.000	A
2	98	0.98	0.000	B
3	98	0.98	0.115	C
4	91	0.91	0.037	D
5	72	0.72	0.046	E
6	38	0.38	0.051	F
7	11	0.11	0.000	G
8	1	0.01	0.077	H
9	0	0.00	0	0

Source: Hypothetical.

- a. From Table 1, calculate the missing values of realised fecundity (from A to H).
- b. Calculate the net reproductive rate  $R_0$  and interpret your results.
- c. How many animals would be produced by this cohort of 100 individuals over their lifetimes? Show your work.
- d. Given that the generation time is 4.5 years, calculate the intrinsic rate of increase ( $r$ ).
- e. From your calculations, do you think that ZAWA is justified with its refusal? Give reasons for your answer.

3. Explain five (5) environmental consequences of high input tropical agricultural systems.
4. Explain the negative effects of weeds on agricultural areas and Identify situations that encourage the spread of weeds.
5. Explain Integrated Pest Management (IPM) is, and how it can be applied in overcoming the problem of pesticide treadmill.
6. Discuss the ecological importance of tropical rainforests and any five problems that adversely affect their normal functioning.

---

End of Examination

**THE UNIVERSITY OF ZAMBIA**  
**SCHOOL OF NATURAL SCIENCES**  
**Department of Mathematics & Statistics**  
**SECOND SEMESTER FINAL EXAMINATIONS**

**April, 2009**  
**M112—MATHEMATICAL METHODS II -A**

**Time allowed : THREE(3) HOURS**

**Instructions** : There are seven(7) questions. Attempt **ANY FIVE (5)** questions. All questions carry equal marks. Show all your working to earn full marks.

**NO CALCULATORS!!**

---

1. (a) If  $(a + x)^n$  is expanded in increasing order of  $x$ , find
- (i) the value of  $n$  if the coefficients of  $x^2$  and  $x^{n-2}$  are equal.
  - (ii) the value of  $a$  if the coefficients of the second and third terms are equal and  $n = 15$ .

(b) Prove by mathematical induction that for all natural numbers  $n \geq 1$ ,

(i)

$$\frac{1}{(1)(3)} + \frac{1}{(3)(5)} + \frac{1}{(5)(7)} + \dots + \frac{1}{(2n-1)(2n+1)} = \frac{n}{2n+1}.$$

(ii) Solve for real values of  $x$ :

$$2^{\frac{2}{\log_5 x}} = \frac{1}{16}.$$

- (c) (i) Write down the first three terms in decreasing powers of  $x$  in the expansion of  $(x^2 - \frac{2}{x^4})^{\frac{1}{2}}$ .
- (ii) Determine the range of values of  $x$  for which the expansion in part (i) is valid.

2. (a) Let  $y = f(x) = x^3 + 3x^2 + 3x + 1$ .
- (i) Find the turning points, (if any).
- (ii) Find the points of inflection, (if any).
- (iii) Hence sketch the graph of  $y = f(x)$ , indicating all the necessary points.
- (b) (i) Express the following as a single logarithm to base 2;  
 $\log_8 2 + c \log_8 d - r \log_8 s$ .
- (ii) Evaluate the following integral:  $\int_0^{\frac{\pi}{4}} \tan^2 x dx$ .

- (c) Prove by mathematical induction that for all natural numbers  $n \geq 1$ ,

$$1 + \cos^2 \theta + \cos^4 \theta + \dots + \cos^{2n} \theta = \frac{1 - \cos^{2n+2} \theta}{\sin^2 \theta}.$$

3. (a) A three-sided fence is to be built next to a straight section of a river, which forms the fourth side of a rectangular region. The area is to equal  $1800\text{m}^2$ . Find the dimensions of the fence which minimize the perimeter.
- (b) Evaluate the following integrals:
- (i)  $\int x \sec^2 x dx$
- (ii)  $\int_1^2 x(x-1)^{15} dx$ .
- (c) Given that  $1 - i\sqrt{3}$  is a root of the equation  $z^4 + 2z^3 + 5z^2 - 2z + 36 = 0$ , find all the other three roots.

4. (a) (i) Sketch the curve with equation  $y = x^3 - x$ .
- (ii) Hence find the area of the finite region enclosed by the curve and the  $x$ -axis.
- (b) (i) Express

$$\frac{x^2 + x + 1}{(x+1)(x^2+1)} \text{ into partial fractions.}$$

- (ii) Hence prove that

$$\int_0^1 \frac{x^2 + x + 1}{(x+1)(x^2+1)} dx = \frac{3}{4} \ln 2 + \frac{\pi}{8}.$$

- (c) Express the following sum of binomial coefficients as a single binomial coefficient of the form  $\binom{n}{r}$ , where  $n, r$  are positive integers with  $r \leq n$ :

$$\binom{7}{3} + \binom{8}{5} + \binom{7}{3}.$$

5. (a) (i) Express the complex numbers  $z = \sqrt{3} + i$  and  $w = 1 - i\sqrt{3}$  in the polar form.
- (ii) Express  $\frac{1-i\sqrt{3}}{(\sqrt{3}+i)^{15}}$  in the form  $a + ib$  where  $a$  and  $b$  are real.
- (b) Solve the equation  $\log_9(x - 5) + \log_9(x + 3) = 1$  for real values of  $x$ .
- (c) (i) Find  $\frac{dy}{dx}$  given that  $y = 2^{x^2+1}$ .
- (ii) Evaluate the following definite integral:

$$\int_{-\frac{\pi}{4}}^{\frac{\pi}{4}} \cos 2x \cos 5x dx.$$

6. (a) Find the fourth roots of  $-81i$  and display them on the Argand diagram.
- (b) Show that  $8^n - 3^n$  is divisible by 5 for all natural numbers  $n \geq 1$ .
- (c) Given the following system of equations

$$4x + 2y - 3z = 2$$

$$2x + y = 1$$

$$5x + 3y + z = 0,$$

- (i) write the system of equations in matrix notation  $AX = B$ , specifying  $A$ ,  $X$  and  $B$ .
- (ii) Hence, use Cramer's rule to solve the system of equations for  $x$ ,  $y$ ,  $z$ .

7. (a) Let  $A = \begin{pmatrix} 1 & 0 \\ 1 & 1 \end{pmatrix}$ . Prove by mathematical induction that  $A^n = \begin{pmatrix} 1 & 0 \\ n & 1 \end{pmatrix}$  for all natural numbers  $n \geq 1$ .

- (b) (i) Obtain the term independent of  $x$  in the expansion of  $(2x^3 - \frac{1}{x})^{20}$ .

[You may leave your answer in terms of factorials]

- (ii) Let  $A = \begin{pmatrix} 1 & 2 & 1 \\ 4 & 0 & 2 \end{pmatrix}$  and  $B = \begin{pmatrix} 3 & 1 & -2 \\ -4 & 5 & 2 \end{pmatrix}$ . Find  $B^T A$ , where  $B^T$  means  $B$  transpose.

- (c) Given the matrix  $A = \begin{pmatrix} 1 & 2 & 3 \\ 3 & 1 & 0 \\ 2 & 2 & 1 \end{pmatrix}$ , find the adjoint of  $A$ , that is  $\text{adj}A$ .

END.

# The University of Zambia

Department of Mathematics and Statistics

END OF SEMESTER 2 EXAMINATIONS 2009

M222 - LINEAR ALGEBRA II

Time allowed: Three (3) hrs

Instructions: (i) Answer any 5 questions.

(ii) All questions carry equal marks

(iii) Show all essential working to earn full marks

---

1. (a) Define the terms

(i) An **inner product** on a vector space  $V$

(ii) **Similar matrices**  $A$  and  $B$

(b) (i) Show that  $\sum_{i=1}^4 \alpha_i \beta_i$  is an inner product on  $V_4(\mathbb{R})$ .

(ii) Show that similar matrices have the same characteristic polynomial.

(c) (i) Find the length of the vector  $(i - 1, i + 1, -i + 1)$  in  $V_3(\mathbb{C})$  with inner product  $\langle u, v \rangle = \sum_{i=1}^3 u_i \bar{v}_i$

(ii) Show that the matrices  $\begin{pmatrix} 1 & 2 \\ 0 & -1 \end{pmatrix}$  and  $\begin{pmatrix} 1 & 0 \\ -2 & -1 \end{pmatrix}$  are similar.

2. (a) Define the following terms

(i) An **eigenvalue** of a matrix  $A$

(ii) The **minimum polynomial** of a matrix  $A$

(b) (i) Prove that if  $n$  is any positive integer and  $\lambda$  is an eigenvalue of  $A$  with corresponding eigenvector  $x$ , then  $\lambda^n$  is an eigenvalue of  $A^n$  with corresponding eigenvector  $x$

(ii) Prove that the minimum polynomial of a matrix is unique.

(c) (i) Find the eigenvalues and corresponding eigenvectors of the matrix  $\begin{pmatrix} 0 & -\sqrt{3} \\ \sqrt{3} & 0 \end{pmatrix}$  over  $\mathbb{C}$ .

(ii) Find the minimum polynomial of the matrix  $\begin{pmatrix} 1 & 2 & 4 \\ 0 & 1 & -1 \\ 0 & 0 & -3 \end{pmatrix}$

3. (a) Define the following terms

(i) An **orthogonal matrix**

(ii) A **QR factorization** of a matrix  $A$

(b) (i) Let  $A$  be an orthogonal matrix. Prove that  $\det(A) = \pm 1$  and  $A^{-1}$  is also orthogonal

(ii) Prove that if  $A \in M_n(\mathbb{R})$  is an orthogonal matrix, then  $\|Ax\| = \|x\|$  for all  $x \in \mathbb{R}^n$ .

(c) (i) Show that the matrix  $\begin{pmatrix} \cos x & -\sin x \\ \sin x & \cos x \end{pmatrix}$  is an orthogonal matrix and find its inverse.

(ii) Find a  $QR$  factorization of the matrix  $\begin{pmatrix} -2 & 1 \\ 3 & -1 \end{pmatrix}$ .

4. (a) What is meant by the terms

(i) The **orthogonal complement** of a subset  $S$  of an inner product space  $V$

(ii) The **direct sum** of a vector space  $V$

(b) (i) Let  $V$  be a finite-dimensional vector space over a field  $\mathbb{K}$  and let  $U$  be a subspace of  $V$ . Prove that there exists a subspace  $W$  of  $V$  such that  $V = U \oplus W$  and  $(V : \mathbb{K}) = (U : \mathbb{K}) + (W : \mathbb{K})$

(ii) Let  $V$  be a vector space and  $U$  and  $W$  be subspaces of  $V$ . If  $V = U + W$ , prove that  $V = U \oplus W$  if and only if  $U \cap W = \{0\}$ .

(c) (i) State the Gram-Schmidt Orthogonalization Theorem.

(ii) Use the Gram-Schmidt Orthogonalization procedure to the vectors  $v_1 = (1, 0, 1)$ ,  $v_2 = (1, 0, -1)$  and  $v_3 = (0, 3, 4)$  to obtain an orthonormal basis for  $V_3(\mathbb{R})$ .

5. (a) What is meant by the terms

- (i) **Characteristic polynomial** of a matrix  $A$   
(ii) A **diagonalizable linear transformation**  $T$
- (b) (i) Prove that a square matrix  $A$  is invertible if and only if 0 is not an eigenvalue of  $A$ .  
(ii) State the Cayley-Hamilton Theorem.
- (c) (i) Find a spectral decomposition of the matrix  $\begin{pmatrix} 0 & -3 \\ -3 & 0 \end{pmatrix}$ .  
(ii) Diagonalize  $\begin{pmatrix} -4 & 3 \\ 0 & 2 \end{pmatrix}$
6. (a) Define the following terms
- (i) **Orthogonally similar** matrices  
(ii) A **real quadratic form** on a vector space  $V$
- (b) (i) Prove that the eigenvalues of a real symmetric matrix are all real.  
(ii) Find  $\begin{pmatrix} 2 & 3 \\ 0 & 1 \end{pmatrix}^{-3} \begin{pmatrix} 1 \\ 1 \end{pmatrix}$ .
- (c) (i) Draw a graph of the conic section  $x^2 - 2xy + y^2 = 4$ .  
(ii) Find an orthogonal matrix  $P$  such that  $P^t A P = \text{diag}(\lambda_1, \lambda_2)$ , where  $A = \begin{pmatrix} -2 & 1 \\ 1 & -2 \end{pmatrix}$ .

**END OF EXAMINATION**

**THE UNIVERSITY OF ZAMBIA**  
**SCHOOL OF NATURAL SCIENCES**  
**DEPARTMENT OF MATHEMATICS & STATISTICS**  
**UNIVERSITY SECOND SEMESTER EXAMINATIONS**  
**APRIL 2009**  
**M232 - REAL ANALYSIS II**

---

**INSTRUCTIONS**

1. Answer any **five(5)** questions.
2. All questions carry equal marks.

**TIME ALLOWED:** Three (3) hours

---

[TURN OVER]

1. (a) Define the following:
    - (i) a sequence in  $\mathbb{R}$ .
    - (ii) a bounded sequence in  $\mathbb{R}$ .
    - (iii) a convergent sequence in  $\mathbb{R}$ .
    - (iv) a limit point of a sequence in  $\mathbb{R}$ .
  - (b) If  $a \in \mathbb{R}$  and  $|a| < 1$ , prove that the sequence  $\{a^n\}_{n=1}^{\infty}$  is convergent.
  - (c) Show that the limit point of a convergent sequence is also a limit of a sequence.
- 

2. (a) Let  $\{x_n\}_{n=1}^{\infty}$  be a sequence in  $\mathbb{R}$ .
    - (i) Define a subsequence of a given sequence.
    - (ii) State when we may write  $+\infty = \lim_{n \rightarrow \infty} x_n$ .
  - (b) Given the sequence  $\left\{ \frac{1}{2}, 2, \frac{1}{3}, \frac{2}{3}, 3, \frac{1}{4}, \frac{3}{4}, 4, \frac{1}{5}, \frac{4}{5}, 5, \dots \right\}$  of real numbers. Determine a subsequence  $\{x_{n_k}\}_{k=1}^{\infty}$  such that  $+\infty = \lim x_{n_k}$  and show that  $+\infty = \lim x_{n_k}$ .
- 

3. (a) Let  $S \subset \tilde{\mathbb{R}}$  ( the extended real numbers). Define the following:
    - (i)  $\sup S$
    - (ii)  $\inf S$
  - (b) Let  $\{x_n\}_{n=1}^{\infty}$  be a sequence in  $\mathbb{R}$ . Define the following:
    - (i)  $\overline{\lim} x_n$
    - (ii)  $\underline{\lim} x_n$
  - (c) Let  $\{x_n\}_{n=1}^{\infty}$  be a sequence in  $\mathbb{R}$ . Suppose that  $\overline{\lim} x_n = \underline{\lim} x_n$ , prove that  $\lim x_n$  exists.
- 

[TURN OVER]

4. (a) Define a Cauchy sequence in  $\mathbb{R}$ .  
(b) If the sequence  $\{x_n\}_{n=1}^{\infty}$  in  $\mathbb{R}$  is a Cauchy sequence, prove that it converges.  
(c) Let  $\{x_n\}_{n=1}^{\infty}$  be a monotonically increasing sequence in  $\mathbb{R}$ . Show that

$$\sup\{x_n : n \in \mathbb{N}\} = \lim_{n \rightarrow \infty} x_n$$

---

5. (a) Define the following:  
(i) an alternating series of real numbers.  
(ii) an absolutely convergent series of real numbers.  
(iii) a rearrangement  $\sum b_n$  of a series  $\sum a_n$ .  
(b) Suppose  $\sum a_n$  is dominated by  $\sum b_n$  and if  $\sum b_n$  converges absolutely, prove that  $\sum a_n$  converges absolutely.  
(c) State without proof D'Alembert's ratio test hence decide whether the series  $\sum_{n=1}^{\infty} \frac{n^n}{n!}$  converges or diverges.
- 

6. (a) Define the following:  
(i) a convergent series of real numbers.  
(ii) a uniformly convergent functional series on a subset  $A$  of  $\mathbb{R}$ .  
(iii) a power series of real numbers.  
(b) State and prove the Cauchy-Maclaurin integral test theorem.  
(c) Show that the series  $\sum_{n=1}^{\infty} \frac{1}{n^p}$  converges if  $p > 1$  and diverges if  $0 < p \leq 1$ .
- 

■ END OF EXAMINATION ■

**THE UNIVERSITY OF ZAMBIA**  
**SCHOOL OF NATURAL SCIENCES**  
**Department of Mathematics & Statistics**  
**SECOND SEMESTER FINAL EXAMINATIONS**

**May, 2009**  
**M412—FUNCTIONS OF A COMPLEX VARIABLE II**

**Time allowed : THREE(3) HOURS**

**Instructions :** There are six(6) questions. Attempt **ANY FIVE (5)** questions. All questions carry equal marks. Show all your working to earn full marks.

---

1. (a) If the function  $f(z)$  is analytic and bounded throughout the complex plane, prove that it is identically constant.

(b) Find the Laurent series expansion of

$$f(z) = \frac{1}{z(z^2 - 3z + 2)}$$

in the annular domain  $0 < |z| < 1$ .

(c) (i) State the Mean Value theorem.

(ii) Verify the Mean Value theorem for the case when  $f(z) = (z + 1)^2$  and  $z_0 = 0$  is the centre of some circular disk of radius  $R$ .

2. (a) State the Maximum Modulus Principle.
- (b) Verify the Maximum Modulus Principle when  $f(z) = (z - 1)^2$  and the region  $R$  is the triangular region with vertices at the points  $z = 0$ ,  $z = -2$  and  $z = i$ .
- (c) In each case below write the principal part of the function at its isolated singularity. Then determine if that singularity is a pole, an essential singularity, or a removable singularity.
- (i)  $f(z) = ze^{\frac{1}{z}}$ .
- (ii)  $f(z) = \frac{\sin z}{z}$ .

3. (a) Without using the Residue theorem, by integrating  $f(z) = \frac{ze^{iz}}{z^2 + a^2}$  around a suitable contour, prove that

$$\int_0^{\infty} \frac{x \sin x}{x^2 + a^2} dx = \frac{\pi}{2e^a}, \quad \text{where } a > 0.$$

- (b) Let  $C$  denote the circle  $|z| = 2$  described in the positive sense. Determine the value of  $\Delta_c \arg f(z)$  for the function

$$f(z) = \frac{z^2 + \left(\frac{1}{2} + \frac{i\sqrt{3}}{2}\right)}{z}.$$

- (c) Find the residue at  $z = 0$  of the function  $f(z) = \frac{1}{\sin z}$ .
4. (a) State and prove the Cauchy Inequality theorem.
- (b) Verify the Cauchy Inequality theorem for the function  $f(z) = \log(1 + z)$  if  $z$  lies on the circle  $|z| = \frac{1}{2}$ .
- (c) Let  $G$  be an open set which is  $a$ -star shaped. Prove that if  $\gamma_0$  is the curve which is constantly equal to  $a$  then every closed rectifiable curve in  $G$  is homotopic to  $\gamma_0$ .

5. (a) (i) State Rouché's theorem.  
(ii) Using Rouché's theorem, find the number of roots of the equation  $z^5 - 12z + 14 = 0$  that lie in the annular domain  $1 < |z| < \frac{5}{2}$ .

(b) Evaluate

$$\int_C \frac{f'(z)}{f(z)} dz$$

if  $C$  is the circle  $|z| = 3\pi$  for

$$f(z) = \frac{2 \cos z - \sqrt{2}}{(z-1)^2(2z+3)}.$$

- (c) (i) Let  $\gamma, \rho: [0, 1] \rightarrow G$  be two closed rectifiable curves in a region  $G$ . Define homotopy between  $\gamma$  and  $\rho$ .  
(ii) If  $\gamma$  is homotopic to  $\rho$ , denoted by  $\gamma \sim \rho$ , prove that the relation ' $\sim$ ' is a symmetric relation.

6. (a) (i) State the residue theorem.  
(ii) Using the residue theorem, show that

$$\int_0^\infty \frac{x^2}{(x^2+9)(x^2+4)^2} dx = \frac{\pi}{200}.$$

- (b) Given the function  $f(z) = \frac{1}{z^2(1-z)}$ , find the Laurent series expansion in powers of  $z$  for  $f(z)$  in the region  $0 < |z| < 1$ .  
(c) State Schwarz Lemma.

**END.**

**THE UNIVERSITY OF ZAMBIA**  
**SCHOOL OF NATURAL SCIENCES**  
**DEPARTMENT OF MATHEMATICS & STATISTICS**  
**UNIVERSITY SECOND SEMESTER EXAMINATIONS**

**APRIL 2009**

**M432 - REAL ANALYSIS VI**

---

**INSTRUCTIONS:**

1. Answer any **five(5)** questions.
2. All questions carry equal marks.

**TIME ALLOWED:** Three (3) hours

---

[TURN OVER]

1. (a) Let  $(X, d)$  be a metric space and  $\{x_n\}_{n=1}^{\infty}$  a sequence in  $X$ .
    - (i) When is  $\{x_n\}_{n=1}^{\infty}$  called a Cauchy sequence?
    - (ii) When is  $X$  said to be complete?
  - (b) The usual metric on  $\mathbb{R}$  is  $d : \mathbb{R} \times \mathbb{R} \rightarrow \mathbb{R}$  defined by  $d(a, b) = |a - b|$ . Prove that  $\mathbb{R}$  is a complete metric space.
  - (c) If  $(X, d)$  is a metric space,  $\{x_n\}_{n=1}^{\infty}$  and  $\{y_n\}_{n=1}^{\infty}$  Cauchy sequences in  $X$ , prove that with the usual metric, the sequence  $\{d(x_n, y_n)\}_{n=1}^{\infty}$  converges in  $\mathbb{R}$ .
2. (a) Let  $X$  and  $Y$  be linear spaces over a field  $\mathbb{F}$ . Define the following:
    - (i) a norm on  $X$ .
    - (ii) a linear transformation  $L : X \rightarrow Y$ .
  - (b) (i) Prove that the norm function  $\|\cdot\| : X \rightarrow \mathbb{R}$  from  $X$  onto  $\mathbb{R}$  is continuous.
    - (ii) Let  $X$  be a linear space. Let  $\|\cdot\| : X \times X \rightarrow \mathbb{R}$  be a norm on  $X$ . Prove that  $|\|x\| - \|y\|| \leq \|x - y\|$  for all  $x, y \in X$ .
  - (c) Let  $X = C[0, 1]$ , Prove that  $\|f\| = \max_{0 \leq x \leq 1} |f(x)|$  defines a norm on  $X$ .
3. (a) Define the following:
    - (i) a Banach space.
    - (ii) an operator on a normed linear space  $X$ .
  - (b) Let  $X$  and  $Y$  be normed linear spaces and  $L$  a linear transformation of  $X$  onto  $Y$ . Prove that the following are equivalent.
    - i.  $L$  is continuous.
    - ii.  $L$  is continuous at the origin.
    - iii. there exists a real number  $K \geq 0$  such that  $\|L(x)\| \leq K\|x\|, \forall x \in X$ .
    - iv. If  $B = \{x : \|x\| \leq 1\}$  is a closed unit ball in  $X$ , then the image  $T(B)$  is a bounded set in  $Y$ .

[TURN OVER]

4. (a) Let  $X$  and  $Y$  be normed linear spaces and  $L \in \mathcal{L}'(X, Y)$ . Let

$$N = \inf\{M \in \mathbb{R} : \|L(x)\| \leq M\|x\|, x \in X\},$$

$$P = \sup\{\|L(x)\| : x \in X, \|x\| \leq 1\} \text{ and}$$

$$S = \sup\{\|L(x)\| : x \in X, \|x\| = 1\}$$

Prove that  $\|L\| = N = P = S$ .

- (b) Let  $X$ ,  $Y$  and  $\mathcal{L}(X, Y)$  be normed linear spaces. Further, let  $\|L\| = \sup\{\|L(x)\| : \|x\| \leq 1\}$  be the norm on  $\mathcal{L}(X, Y)$ . Prove that if  $Y$  is a Banach space, then so is  $\mathcal{L}(X, Y)$ .

- (c) Show that  $l_2$  with an inner product of two vectors

$$x = (x_1, x_2, \dots, x_n, x_{n+1}, \dots)$$

$$y = (y_1, y_2, \dots, y_n, y_{n+1}, \dots)$$

defined by  $\langle x, y \rangle = \sum_{i=1}^{\infty} x_i \bar{y}_i$  is an inner product space.

5. (a) Let  $X$  be a normed linear space over a field  $\mathbb{F}$ . Define the following:

(i) the conjugate space  $X^*$  of  $X$ .

(ii) a bounded linear functional  $f$  on  $X$ .

- (b) Prove that a linear functional  $f$  defined on a normed linear space  $X$  is bounded if and only if it is continuous.

- (c) Prove that the space  $(l_p^n)^*$  is isometrically isomorphic to  $l_q^n$ , where  $\frac{1}{p} + \frac{1}{q} = 1$ .

6. (a) Define the following:

(i) a Hilbert space  $H$ .

(ii) an orthonormal set  $S$  in a Hilbert space  $H$

- (b) (i) Let  $X$  be an inner product space. Let  $x \in X$ , prove that  $\{x\}^\perp$  is a closed subspace of  $X$ .

(ii) Let  $H$  be a Hilbert space. Prove that  $\|x\|^2 = \sum |\langle x, e_i \rangle|^2$  for all  $x \in H$  implies that  $\{e_i\}$  is a complete orthonormal subset in  $H$ .

- (c) If  $M$  is a proper closed linear subspace of a Hilbert space  $H$ , prove that there exists a non zero vector  $z_0$  in  $H$  such that  $z_0 \perp M$ .

■ END OF EXAMINATION ■



# THE UNIVERSITY OF ZAMBIA

DEPARTMENT OF PHYSICS  
UNIVERSITY EXAMINATIONS  
SECOND SEMESTER 2007/2008

## P252-CLASSICAL MECHANICS II

TIME ALLOWED: **THREE HOURS**

TOTAL MARKS: **100**

**INSTRUCTIONS:** ATTEMPT ANY FIVE (5) QUESTIONS FROM THE SEVEN GIVEN. ALL QUESTIONS CARRY EQUAL MARKS. MARKS WILL BE AWARDED FOR CLEAR ANSWERS AND SOLUTIONS SHOWING ALL THE CORRECT STEPS.

The following information may be useful.

The speed of light  $c = 3.0 \times 10^8 \text{ ms}^{-1}$

Rest mass of electron  $m_0 = 9.1 \times 10^{-31} \text{ kg}$

Acceleration due to gravity  $g = 9.8 \text{ ms}^{-2}$

- Q1. (a) (i)** In one line, state what the first postulate of the special theory of relativity is about. [1½]
- (i)** In one line, state what the second postulate of the special theory of relativity is about. [1½]
- (b)** An electron is traveling at 290,000km/s. Calculate
- (i)** its kinetic energy (KE) and [7]
- (ii)** its momentum. [4]
- (c)** Two events separated by a distance 10 meters on the x-axis in a given frame of reference occur 1 microsecond apart. What is the velocity of a frame in which the separation in time is 2 microseconds? [6]

**Q2.** A forced harmonic oscillator is represented by the equation

$$\ddot{x} + k\dot{x} + \omega^2 x = F_0 \sin pt.$$

**(a)** Show that the particular solution to this equation given by

$$x_i(t) = B \sin pt + C \cos pt$$

where  $B$  and  $C$  are constants leads to

$$x_i(t) = \frac{F_0}{[(\omega^2 - p^2)^2 + p^2 k^2]} [(\omega^2 - p^2) \sin pt - pk \cos pt] \quad [17]$$

**(b)** Identify the damping constant for the forced harmonic oscillator in Q2.(a), hence obtain the expression for the maximum amplitude if the damping is removed. [3]

**Q3.** Starting from the equation of motion for the damped harmonic oscillator

$$m\ddot{x} + c\dot{x} + kx = 0.$$

**(a)** Show that the position as a function of time is given by

$$x(t) = Ae^{-\lambda t} \sin(\omega t + \delta)$$

if the oscillator is underdamped. [10]

**(b)** A damped oscillator consists of a mass  $m = 5 \times 10^{-4}$  kg attached to a spring of spring constant  $k = 0.05 \text{ Nm}^{-1}$  and the damping constant  $c = 5 \times 10^{-5} \text{ Nsm}^{-2}$ . Find its position as a function of time if at  $t = 0$  its displacement from the equilibrium position is 1.0cm and its velocity is zero. [10]

**Q4.(a)** The wave equation for waves on a string of length  $L$  is given by

$$\frac{\partial^2 y(x,t)}{\partial t^2} = v^2 \frac{\partial^2 y(x,t)}{\partial x^2}.$$

After separation of variables, the space part of the wave is found to be

$$\frac{d^2 X(x)}{dx^2} + \frac{\omega^2}{v^2} X(x) = 0$$

where  $\omega$  is the frequency and  $v$  is the velocity.

**(i)** Prove that if the string is clamped at both ends, the solution to the space part is

$$X(x) = A \sin \frac{\omega}{v} x. \quad [7]$$

**(ii)** Obtain the normal frequencies of the string. [2]

**(b)** The displacement of a vibrating string is given by

$$y(x,t) = A \sin kx \cos \omega t$$

The string has a length of 75cm, a mass per unit length of 0.1g and is under a tension of 2000N. If the string is vibrating at its fundamental frequency and its total energy is 1.5 J. Calculate the

- (i) wavelength, [1]
- (ii) period and [2]
- (iii) amplitude of the motion. [8]

**Q5.** A double pendulum consists of two massless rigid rods (see figure below). The first rod, of length  $l_1$  has one end attached to a point of suspension O and the other end to a second rod of length  $l_2$ . The first mass  $m_1$  is attached to the joint of the rods and the second mass  $m_2$  is attached to the end of the second rod. Both the point of support and the joint are frictionless. The angle which the rod of length  $l_1$  makes with the vertical is  $\theta_1$ , while the angle which the rod of length  $l_2$  makes with the vertical is  $\theta_2$ . A Cartesian system is constructed with the origin at O, the positive  $y$ -direction being downwards and the positive  $x$ -direction pointing to the right.

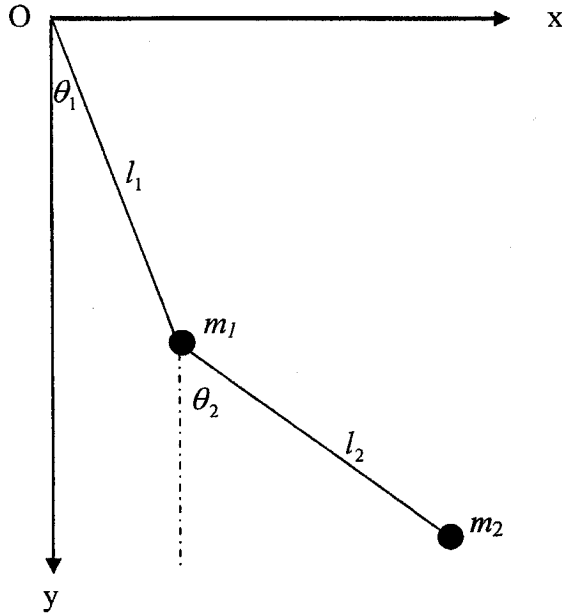

- (a) Show that  
 (i) the Cartesian coordinates of the masses are [2]

$$\begin{aligned} x_1 &= l_1 \sin \theta_1 & y_1 &= l_1 \cos \theta_1 \text{ and} \\ x_2 &= l_1 \sin \theta_1 + l_2 \sin \theta_2 & y_2 &= l_1 \cos \theta_1 + l_2 \cos \theta_2 \end{aligned}$$

- (ii) the particles have kinetic energies [8]

$$T_1 = \frac{1}{2} m_1 l_1^2 \dot{\theta}_1^2$$

$$T_2 = \frac{1}{2} m_2 [l_1^2 \dot{\theta}_1^2 + l_2^2 \dot{\theta}_2^2 + 2l_1 l_2 \dot{\theta}_1 \dot{\theta}_2 \cos(\theta_1 - \theta_2)].$$

- (b) Find the potential energy and the expression for the Lagrangian, hence show that the equations of motions are [10]

$$(m_1 + m_2)l_1^2 \ddot{\theta}_1 + m_1 l_1 l_2 \ddot{\theta}_2 \cos(\theta_1 - \theta_2) + m_2 l_1 l_2 \dot{\theta}_2^2 \sin(\theta_1 - \theta_2) + (m_1 + m_2)gl_1 \sin \theta_1 = 0.$$

$$\text{and } (m_2 l_2^2 \ddot{\theta}_2 + m_2 l_1 l_2 \ddot{\theta}_1 \cos(\theta_1 - \theta_2) - m_2 l_1 l_2 \dot{\theta}_1^2 \sin(\theta_1 - \theta_2) + m_2 g l_2 \sin \theta_2 = 0.$$

**Q6.(a)** Use the Hamiltonian approach to obtain the equations of motion for a projectile which is launched near the surface of the earth at an angle  $\alpha$  to the horizontal with a velocity  $\bar{v}$ . [14]

**(b)** Solve the equations of motion in (a) and obtain the expressions for  $x(t)$  and  $y(t)$  at any time  $t$  given that the projectile is launched at an angle  $\alpha = 30^\circ$  with a velocity of 50m/s. [4]

**(a)** Deduce the maximum height of the projectile described in (b) above. [2]

**Q7. (a)** The displacement of a vibrating string is given by

$$y = 0.01 \cos(3x - 7t) \text{ meters.}$$

**(i)** Obtain the velocity of the point at  $x = 3.5$  m when  $t = 3$  sec. [3]

**(ii)** Obtain the velocity of waves on the string. [3]

**(iii)** Obtain the wavelength of the waves on the string. [1]

**(iv)** Obtain the period of the wave. [1]

**(b)** Two events occur at the same time at the points  $x = 1$ m and  $x = 10$ m. How far apart are the events in time if viewed from a frame that moves with a velocity  $c/2$  along the  $x$  direction? ( $c$  is the speed of light). [4]

**(c)** Use Hamilton's method to derive an expression for the motion of a particle in Cartesian coordinates for simple harmonic motion in one dimension. [4]

**(d)** The differential equation of motion of a critically damped harmonic oscillator is given by

$$\ddot{x} + 2\gamma\dot{x} + \omega_0 x = 0.$$

If one of the solutions is  $x = e^{-\gamma t}$ , show that the other solution is  $x = te^{-\gamma t}$ . Without solving the differential equation, write down the general solution. [4]

\*\*\*\*\*END OF P252 EXAMINATION\*\*\*\*\*



## THE UNIVERSITY OF ZAMBIA PHYSICS DEPARTMENT

**SECOND SEMESTER UNIVERSITY EXAMINATION 2007/2008**

**P 272 -THERMAL PHYSICS AND OPTICS**

**TIME: THREE HOURS**

**MAX. MARKS: 100**

**ANSWER ANY FIVE QUESTIONS**

---

### FORMULAE

1.  $1 \text{ bar} = 10^5 \text{ Pa}$
2.  $C_p = 1.005 \text{ kJ}/(\text{kg K})$ ,  $C_v = 0.715/(\text{kg K})$
3. Specific enthalpy of liquid water  
at  $16^\circ\text{C} = 67218 \text{ J}/(\text{kg K})$  and  
at  $32^\circ\text{C} = 134101 \text{ J}/(\text{kg K})$
4. Specific enthalpy of steam at a pressure of  $2 \text{ MN}/\text{m}^2$  and at a temperature of  $300^\circ\text{C} = 3025 \text{ kJ}/\text{kg}$

Specific enthalpy of steam at a pressure of  $800 \text{ kN}/\text{m}^2$  and with a dryness fraction of  $0.9 = 2562.75 \text{ kJ}/\text{kg}$ .

Saturation temperature at a pressure of  $2 \text{ MN}/\text{m}^2 = 212.4^\circ\text{C}$ .

Specific enthalpy of steam at a pressure of  $800 \text{ kN}/\text{m}^2 = 2767.5 \text{ kJ}/\text{kg}$

Specific liquid enthalpy =  $720.9 \text{ kJ}/\text{kg}$

Specific enthalpy of evaporation =  $2046.5 \text{ kJ}/\text{kg}$

## QUESTION 1

- (a) A gas has a density of  $0.09 \text{ kg/m}^3$  at a temperature of  $0^\circ\text{C}$  and a pressure of  $1.015 \text{ bar}$ . Determine,
- (i) the characteristic gas constant; **(5marks)**
  - (ii) the specific volume of the gas at a temperature of  $70^\circ \text{C}$  and a pressure of  $2.07 \text{ bar}$ . **(5 marks)**
- (b) If a volume of  $5.6 \text{ m}^3$  of the gas at an initial pressure of  $1.02 \text{ bar}$  and temperature  $0^\circ \text{C}$  is heated at constant pressure to a final temperature of  $50^\circ\text{C}$ , determine;
- (i) the heat transfer; **(10 marks)**

## QUESTION 2

- (a) Considering unit mass of a gas, show that the change of specific entropy of a gas from a knowledge of temperature and volumes is given as: **(10 marks)**

$$S_2 - S_1 = c_v \ln \frac{T_2}{T_1} + R \ln \frac{V_1}{V_2}$$

Where

- $S_2 - S_1$  is the change of specific entropy of the gas;
- $c_v$  is the specific heat capacity of the gas at constant volume,
- $T_1$  is the absolute temperature of the gas when it is in state 1,
- $T_2$  is the absolute temperature of the gas when it is in state 2;
- $R$  is the characteristic constant of the gas;
- $V_1$  is the specific volume of the gas when it is in state 1,
- $V_2$  is the specific volume of the gas when it is in state 2.

- (b) A quantity of air has an initial pressure, volume and temperature of  $2.72 \text{ MPa}$ ,  $3 \text{ litres}$  and  $260^\circ\text{C}$ , respectively. It is expanded to a pressure of  $0.34 \text{ MPa}$  according to the law  $PV^{1.25} = \text{constant}$ . Determine the change of entropy and state whether it is an increase or decrease. **(10 marks)**

### QUESTION 3

- (a) A calorimeter of mass 0.11 kg contains 0.34 kg of water. The initial temperature of the water and calorimeter is 16° C. A piece of solid of mass 0.41 kg is heated to a temperature of 100° C and at this temperature it is immersed in the water of the calorimeter. The temperature of the calorimeter system rises to 32° C, neglecting heat loss and the water equivalent of the calorimeter, estimate the specific heat capacity of the solid. **(5 marks)**
- (b) If the specific heat capacity of the material of the calorimeter in question 3 (a) is 394J/kgK, find the water equivalent of the calorimeter. **(5 marks)**.
- (c) Steam at a pressure of 2 MN/m<sup>2</sup>, and a temperature of 300 °C, flowing at a rate of 2 kg per second is throttled to a pressure of 800 kN/m<sup>2</sup>. It is then mixed with steam at a pressure of 800 N/m<sup>2</sup> and 0.9 dry which flows at a rate of 5 kg per second. Determine the,
- (i) condition of the resulting system mixture, **(5 marks)**
- (ii) internal diameter of the pipe to convey the steam at 2 MN/m<sup>2</sup> if the velocity of the steam is limited to 15 meters per second **(5 marks)**

### QUESTION 4

- (a) In a Young's two-slit experiment,  $S_1$  and  $S_2$  are two coherent light sources separated by a distance of 0.5 mm and O is a point equidistant from  $S_1$  and  $S_2$ . O is on a screen A, which is 0.80 m from the slit.

When a thin parallel-sided piece of glass of thickness  $3.6 \times 10^{-6}$  m is placed near  $S_1$  the centre of the fringe system moves from O to a point P on the screen A. Calculate OP if the wavelength of the monochromatic light from the two slits is  $6.0 \times 10^{-7}$  m and the refractive index of the glass is 1.5. **(10 Marks)**

- (b) Light containing two wave lengths  $\lambda_1$  and  $\lambda_2$  falls normally on a plano-convex lens of radius of curvature R resting on a glass plate. If the  $n^{\text{th}}$  dark ring due to  $\lambda_1$  coincides with the  $(n+1)^{\text{th}}$  dark ring due to  $\lambda_2$ , prove that the radius of the  $n^{\text{th}}$  dark ring of  $\lambda_1$  is

$$r_n = \sqrt{\frac{\lambda_1 \lambda_2}{\lambda_1 - \lambda_2}} R \quad \text{(10 marks)}$$

### QUESTION 5

- (a) Two optically flat glass plates, in contact along one edge, make a very small angle with each other. They are illuminated by red light of wavelength 750nm and blue light of wavelength 450nm. Looking down on the wedge the first place where it appears purple is 5.0 mm from the line of contact. If red and blue light together produce purple light, find the angle between the plates. **(10 marks)**
- (b) In a Newton's rings experiment, the diameter of the 10<sup>th</sup> ring changes from 1.40 cm to 1.27 cm when a liquid is introduced between the lens and the plate. Calculate the refractive index of the liquid. **(10 marks)**

### QUESTION 6

- (a) A parallel beam of sodium light is incident normally on a diffraction grating. The angle between the two first order spectra on either side of the normal is 27° 42'. Assuming that the wave length of the light is 5.893 X 10<sup>-7</sup>m, find the
- (i) number of rulings per mm on the grating, and  
(ii) greatest number of bright images obtained. **(10 marks)**
- (b) Explain what is meant by the statement that a beam of light is plain-polarised. Describe an experiment that demonstrates polarisation of light by reflection. **(10 marks)**

### QUESTION 7

- (a) Explain in details the concept of displacement current **(3 marks)**
- (b) Write Maxwell's equations in both vector notation and differential equations form. **(6 marks)**
- (c) Show that the orbit radius of an electron circulating around the nucleus of charge Ze is given by the formula **(6 marks)**

$$r^2 = \frac{n^2 \hbar^2}{me^2 Zk}$$

- where m is the mass of an electronic  
n is the whole number called the principal quantum number;  
e is the charge;  $\hbar$  Planck's constant of action ( h divided by 2π );  
z is the atomic number;
- (d) State laser applications **(5 marks)**



UNIVERSITY OF ZAMBIA  
DEPARTMENT OF PHYSICS  
2009 SECOND SEMESTER UNIVERSITY EXAMINATIONS

P332  
STATISTICAL PHYSICS

- 
- DURATION:** Three hours.
- INSTRUCTIONS:** Answer any four questions from the six given.  
*Each question carries 25 marks with the division of marks within each question indicated by the numbers in parenthesis next to the question.*
- MAXIMUM MARKS:** 100
- DATE:** WEDNESDAY 15<sup>th</sup> April 2009.
- 

Formulae that may be needed:

- $\ln n! = n \ln n - n$
  - $f(a+h) = f(a) + \frac{h}{1!} f'(a) + \frac{h^2}{2!} f''(a) + \dots + \frac{h^n}{n!} f^{(n)}(a) + \dots$
  - Definition of generalized force  
$$\chi_\alpha = \frac{\partial E}{\partial x_\alpha}$$
  - Mean work  $\overline{dW}$   
$$\overline{dW} = \sum_{\alpha=1}^n \overline{\chi_\alpha} dx_\alpha$$
  - $$\frac{1}{1-x} = 1 + mx + \frac{m(m+1)}{2!} x^2 + \frac{m(m+1)(m+2)}{3!} x^3 + \dots$$
- 

**QUESTION 1**

- (a) In the problem of the random walk, with each step of equal length, the probability  $P(m)$  of a particle being  $m$  steps from the origin after  $N$  steps is given by

$$P_N(m) = \frac{N!}{(N-n_1)!n_1!} p^{n_1} q^{(N-n_1)}$$

The symbols have their usual meaning which you must give. Prove the above formula from first principles. (20 marks)

- (b) For  $N = 3$  in the random walk problem with equal step length, draw a table to show the possible values of  $n_1$ ,  $n_2$ ,  $m$  and the number of ways the same value of  $n_1$ ,  $n_2$  and  $m$  can occur. Show the latter diagrammatically with arrows. Use the table or otherwise to give the probabilities for all the possible values of  $m$ .

(5 marks)

### QUESTION 2

- (i) Describe in detail, including mathematical steps, the thermal interaction of two systems  $A$  and  $A'$  with a view to deriving the condition for  $P(E)$  to be a maximum and give the three forms of this condition. (20 marks)
- (ii) What can you say about the state  $A$  and  $A'$  when  $P(E)$  is a maximum? (2 marks)
- (iii) From the derivation above identify and state the three equivalent conditions for equilibrium. (3 marks)

### QUESTION 3

- (a) Use the relations

$$\beta = \frac{\partial \ln \Omega}{\partial E}, \quad \bar{x}_\alpha = \frac{1}{\beta} \frac{\partial \ln \Omega}{\partial x_\alpha}, \quad \Omega = CV^N \chi(E)$$

to answer the following questions:

- (i) Give the expression for pressure when only one external parameter, the volume  $V$ , describes the system. (3 marks)
- (ii) Use your result and the above equations to derive the equation of state for an ideal gas. (4 marks)
- (iii) Show that the energy of an ideal gas depends only on temperature, but not on volume. (3 marks)
- (b) Derive the expression for a canonical distribution by considering a system in contact with a heat reservoir. (15 marks)

### QUESTION 4

- (a) Consider an isolated system consisting of a large number  $N$  of a very weakly interacting localized particle of spin  $\frac{1}{2}$ . Each particle has a magnetic moment  $\mu$  which can point either parallel or antiparallel to an applied field  $H$ . The energy  $E$  of the system is then  $E = -(n_1 - n_2)\mu H$ , where  $n_1$  is the number of spins aligned antiparallel to  $H$ .
- (i) Consider the energy range between  $E$  and  $E + \delta E$  where  $\delta$  is very small compared to  $E$  but is macroscopically large so that  $\delta E \gg \mu H$ . What is the total number of states  $\Omega(E)$  lying in this energy range? (7 marks)
- (ii) Write down an expression for  $\ln \Omega(E)$  as a function of  $E$ . Simplify this expression by applying Stirling's formula in simplest form. (9 marks)
- (b) Consider a system of 5 spin- $\frac{1}{2}$  particles in equilibrium in a magnetic field  $H$ . The total energy is measured to be  $-\mu H$ .
- (i) Calculate the probability for an electron to have spin parallel to  $H$ . (3 marks)
- (ii) Calculate the probability for an electron to have spin antiparallel to  $H$ . (3 marks)
- (iii) Calculate the mean value of the magnetic moment  $\mu$ . (3 marks)

### QUESTION 5

(a) A box is separated by a partition which divides its volume in the ratio 3:1. The larger portion of the box contains 1000 molecules of Ne gas; the smaller, 100 molecules of He gas. A small hole in the partition, and one waits until equilibrium is attained.

(i) Find the mean number of molecules of each type on either side of the partition. (4 marks)

(ii) What is the probability of finding 1000 molecules of Ne gas in the larger portion and 100 molecules of He gas in the smaller (i.e. the same distribution as in the initial system)? (4 marks)

(b) Using the canonical ensemble

$$P_r = \frac{\exp(-\beta E_r)}{\sum_r \exp(-\beta E_r)}$$

derive expressions in terms of the *Zustandsumme* for

(i) the mean energy  $\bar{E}$ , (4 marks)

(ii) the dispersion  $\overline{(\Delta E)^2}$ , (6 marks)

(iii) the work done  $dW$  by a quasi-static system characterized by a single external parameter. (5 marks)

(vi) the generalized force  $\chi$  for the system of part (iii). (2 marks)

### QUESTION 6

For a gas of identical particles in a volume  $V$  in equilibrium at temperature  $T$  the partition function is

$$Z = \sum_R \exp(-\beta E) = \sum_R \exp[-\beta(n_1 \epsilon_1 + n_2 \epsilon_2 + \dots)]$$

(a) The mean  $\bar{n}_s$  of the number of particles in state  $s$  is

$$\bar{n}_s = \frac{\sum_R n_s \exp[-\beta(n_1 \epsilon_1 + n_2 \epsilon_2 + \dots)]}{\sum_R \exp[-\beta(n_1 \epsilon_1 + n_2 \epsilon_2 + \dots)]}$$

Express this in terms of  $Z$ . (5 marks)

(b) Put your result for  $\bar{n}_s$  from part (a) in the form of a product of sums. (3 marks)

(c) Derive  $\bar{n}_s$  for the Fermi-Dirac case. (17 marks)

————— END —————



**The University of Zambia**  
**Physics Department**  
**University Examinations 2007/2008**  
**Second Semester**  
**P-412 : Nuclear Physics**

All questions carry equal marks. The marks are shown in brackets. Attempt any four questions. Clearly indicate on the answer script cover page which questions you have attempted.

Time : Three hours.

Maximum marks = 100.

Do not forget to write your computer number clearly on the answer book.

=====

Wherever necessary use :

$\epsilon_0 = 8.85 \times 10^{-12} \text{ C}^2/\text{Nm}^2$	$m_{\text{hydrogen atom}} = 1.007825 \text{ a.m.u.}$
$m_n = 1.008665 \text{ a.m.u.} = 939.551 \text{ MeV}$	$m_{\text{alpha}} = 4.002603 \text{ a.m.u.}$
$1 \text{ a.m.u.} = 931.5 \text{ MeV} = 1.6604 \times 10^{-27} \text{ kg}$	$m_p = 1.67 \times 10^{-27} \text{ kg} = 938.28 \text{ MeV}$
$c = 3 \times 10^8 \text{ m/s}$	$m_e = 9.11 \times 10^{-31} \text{ kg} = 0.511 \text{ MeV}$
$h = 6.63 \times 10^{-34} \text{ J-s}$	$e = 1.6 \times 10^{-19} \text{ C}$
$\hbar = 6.58 \times 10^{-22} \text{ MeV-s} = 1.05 \times 10^{-34} \text{ J-s}$	$1\text{eV} = 1.6 \times 10^{-19} \text{ J}$
$1 \text{ fermi} = 10^{-15} \text{ m}$	$1 \text{ barn} = 10^{-28} \text{ m}^2$
Avogadro's constant = $6 \times 10^{23}$ per mole	Velocity of light = $3 \times 10^8 \text{ m.sec}^{-1}$ .
$\frac{e^2}{4\pi\epsilon_0} = 1.44 \text{ MeV-fermi}$	$\hbar c = 197.33 \text{ MeV-fermi}$ $m = \frac{m_0 c^2}{c^2} \equiv \frac{\text{MeV}}{c^2}$

$$(1s_{1/2})^2, (1p_{3/2})^4, (1p_{1/2})^2, (1d_{5/2})^6, (2s_{1/2})^2, (1d_{3/2})^4, (1f_{7/2})^8, (2p_{3/2})^4, (1f_{5/2})^6, \\ (2p_{1/2})^2, (1g_{9/2})^{10}, [50]. E = \frac{\hbar^2}{2\mathfrak{I}} [J(J+1) - BJ^2(J+1)^2]. \Delta E_C = \frac{3}{5} \frac{e^2}{R} [Z^2 - (Z+1)^2]$$

**Q1.** The electrostatic energy of a charge  $q$  uniformly distributed throughout a sphere of radius  $R$  is  $U = \frac{3}{5} \frac{e^2}{R} \frac{1}{4\pi\epsilon_0}$ , [ $W_{Coul.} = \frac{3}{5} \frac{q^2}{R}$ ].

(i) Using this in the case of positron beta decay, derive an expression for the decrease in Coulomb energy. [8]

(ii) Hence calculate the predicted value of the maximum kinetic energy of the positrons emitted by  ${}^{23}_{12}\text{Mg} \rightarrow {}^{23}_{11}\text{Na} + \beta^+$  using the constant-density nuclear model,  $R = r_0 A^{1/3}$  where  $r_0 = 1.45 \times 10^{-13} \text{ cm}$ . Assume the nuclear binding energy to be the same in both the nuclei. [12+5]

**Q 2.** A neutron is bound in the lowest possible state ( $l = 0$ ) to a heavy nucleus. The binding energy is  $E_B = 25 \text{ MeV}$  ( $E = -25 \text{ MeV}$ ). The potential acting on the neutron is  $V_0 = 50 \text{ MeV}$ ; the radius  $r_0$  of the well is not known :

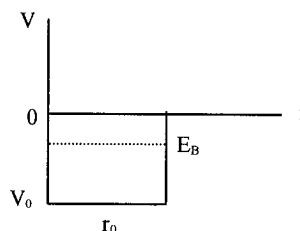

- i) solve the radial wave equation for  $l = 0$  inside and outside the well, and sketch the wave function  $u$  [8]
- ii) apply boundary conditions at  $r = r_0$  to obtain an equation between the pertinent wave numbers and  $r_0$  [8]
- iii) find the numerical values of the wave numbers and solve the equation mentioned under (ii) for  $r_0$ . [9]

(For the reduced mass use  $m = 1 \text{ a.m.u.}$ ).

**Q 3.** The semi-empirical mass formula for the mass of a neutral atom is

$$M(A, Z) = ZM_p + (A-Z)M_N - c_v A + c_A A^{2/3} + c_c \frac{Z(Z-1)}{A^{1/3}} + c_s \frac{(A-2Z)^2}{A} \pm \delta,$$

where  $M_H$  and  $M_N$  are the masses of the hydrogen atom and the neutron respectively in atomic mass units.

- (i) Show that it can be written for a given  $A$  as  $M(Z, A) = \alpha A + \beta Z + \gamma Z^2 \pm \delta$  where  $\alpha$ ,  $\beta$ , and  $\gamma$  are appropriately defined constants and  $\delta$  is the pairing energy contribution. [4]
- (ii) Hence show that the reaction energy  $Q$  for  $\beta^-$  - decay and  $\beta^+$  - decay  $Z \Rightarrow (Z+1)$  and  $Z \Rightarrow (Z-1)$  at constant even  $A$  becomes  $Q = 2\gamma (+ (Z_{min} - Z) - (1/2)) \pm 2\delta$  and  $Q = 2\gamma (- (Z_{min} - Z) - (1/2)) \pm 2\delta$  where  $Z_{min}$  is the charge of the most stable isobar. [16]

(iii) Use the expression  $Z_{min} = \frac{\beta}{2\gamma} = \frac{4a_4 + M_n - M_p}{2 \left[ \frac{a_3}{A^{1/3}} + \frac{4a_4}{A} \right]}$  to establish whether

${}^{142}_{54}\text{Xe}$  is  $\beta^-$  unstable or  $\beta^+$  unstable. [5]

Given,  $a_1 = 14.1$  MeV     $a_2 = 13$  MeV     $a_3 = 0.595$  MeV     $a_4 = 19$  MeV, and  $a_5 = 33.5$  MeV.

**Q4. (a)** How does the inclusion of a strong spin-orbit coupling in the single-particle shell model of the nucleus lead to the splitting of a state of given  $l$ ? Show that the splitting is proportional to  $(2l + 1)$ . [12]

**(b)** The ground state spins and parities of the following nuclei are given in brackets. Compare these values with the predictions of the single-particle shell model of the nucleus.  ${}^{11}_5\text{B}(\frac{3^-}{2})$ ,  ${}^{16}_7\text{N}(2^-)$ , and  ${}^{25}_{13}\text{Al}(\frac{5^+}{2})$ . [6]

**(c)** The ground state of  ${}^{39}_{20}\text{Ca}$  has spin-parity value of  $\frac{3^+}{2}$ . The next higher states have  $\frac{1^+}{2}$ ,  $\frac{7^-}{2}$  and  $\frac{3^-}{2}$ . Interpret these values on the basis of the single-particle shell-model. [7]

**Q5(a)** (i) Explain in short the terms "allowed" and "forbidden" beta transitions and "degree of forbiddenness". [9]

(ii) Distinguish between the Fermi and the Gamow-Teller selection rules in beta decay of nuclei. [6]

On the basis of these selection rules, deduce :

- (i) the degree of forbiddenness, and
- (ii) the type (Fermi, G-T, or mixed) of the following  $J^\pi$  beta transitions :

$$0^+ \rightarrow 1^+ \quad \frac{5^+}{2} \rightarrow \frac{7^-}{2} \quad \frac{1^+}{2} \rightarrow \frac{1^+}{2} \quad 0^+ \rightarrow 0^+ \quad [6]$$

**(b)** What do you understand by "super-allowed" transitions? Under what circumstances is such a transition most probable? [4]

**Q6. (a)** Show that an alpha particle with total energy  $E_0$  incident on a potential barrier of energy  $V$  ( $V > E_0$ ) and of thickness  $b$  has a quantum probability of penetrating it. [9]

**(b)**  ${}^{108}_{47}\text{Ag}$  has a spin and parity  $1^+$ . It is beta-unstable with a mean life-time of 3.4 minutes. It has an excited state at 109 keV excitation energy, spin and parity  $6^+$ , which is an isomeric state with a mean life of 180 years. Explain how an excited state of a nucleus can be more stable than the ground state. Draw the energy level diagram. [4]

**(c)** A fictitious nuclide has a  $J = 1/2^+$  ground state and approximately evenly spaced excited states with  $J = 9/2^+, 3/2^-, 1/2^+, 5/2^+, 7/2^-$  in order of ascending energy.

(i) Draw an energy level diagram for this nuclide [3]

(ii) Indicate on this diagram the most likely gamma transition (down) from each level (five lines in all). Write beside the lines their multipolarity ( $E_1, M_2$  etc). [5]

**(d)** Explain the origin of electric and magnetic multipole transitions in gamma decay of a nucleus. [4]

**==0==**

**THE UNIVERSITY OF ZAMBIA**  
**PHYSICS DEPARTMENT**  
**UNIVERSITY OF ZAMBIA**  
**SECOND SEMESTER EXAMINATIONS 2009**  
*P455 QUANTUM MECHANICS II*

---

TIME : THREE HOURS  
ANSWER : ANY FOUR QUESTIONS  
MAXIMUM MARKS : 100

---

Useful information:

$$\begin{vmatrix} H'_{11} - E^{(1)} & H'_{12} & \dots & H'_{1\alpha} \\ H'_{21} & H'_{22} - E^{(1)} & \dots & H'_{2\alpha} \\ \vdots & \vdots & \dots & \vdots \\ H'_{\alpha 1} & H'_{\alpha 2} & \dots & H'_{\alpha\alpha} - E^{(1)} \end{vmatrix} = 0$$

$$c_{ba}^{(1)} = \frac{1}{i\hbar} \int_0^t H'_{ba}(t') \exp(i\omega_{ba}t') dt'$$

$$E_n^{(1)} = \langle \psi_n^{(0)} | H' | \psi_n^{(0)} \rangle$$

$$\phi(p_x) = \frac{1}{\sqrt{2\pi\hbar}} \int_{-\infty}^{\infty} \psi(x) e^{-ip_x x} dx$$

$$\int_{-\infty}^{\infty} e^{-\beta x^2} dx = \sqrt{\frac{\pi}{\beta}}, \quad \int_{-\infty}^{\infty} x^2 e^{-\beta x^2} dx = \frac{1}{2\beta} \sqrt{\frac{\pi}{\beta}}$$

---

1. (a) One of the dynamical variables  $A$  of a certain system satisfies the eigenvalue equation

$$A\phi_n = a_n\phi_n.$$

(i) Prove that if the orthonormal eigenfunctions of  $A$  are used as the basis, the expectation value of another dynamical variable  $B$  in the normalised state  $\Psi$  can be written as

$$\langle B \rangle = [\Psi]^\dagger [B] [\Psi],$$

where

$$[\Psi] = \begin{pmatrix} c_1 \\ c_2 \\ \vdots \\ c_N \end{pmatrix}$$

and

$$[B] = \begin{pmatrix} B_{11} & B_{12} & \dots & B_{N1} \\ B_{21} & B_{22} & \dots & B_{N2} \\ \vdots & \vdots & \ddots & \vdots \\ B_{N1} & B_{N2} & \dots & B_{NN} \end{pmatrix}.$$

[7 marks]

(ii) Show that

$$c_i = \int \phi_i^* \Psi d\tau$$

and give the formula for  $B_{ij}$ .

[3 marks]

(iii) Hence show that the matrix representation of the differential operator  $A$  is diagonal. [2 marks]

(b) The momentum-space eigenfunction of a system is  $\Phi(p_x, t)$ . What is the interpretation of this quantity? [2 marks]

(ii) Write down the time-dependent Schrödinger equation in momentum space for the one-dimensional harmonic oscillator. [2 marks]

(iii) Prove that the wave functions of the oscillator are given by

$$\Phi(p_x, t) = \phi(p_x) e^{-i\omega t}$$

where  $\phi(p_x)$  is the solution of the time-independent Schrödinger equation in momentum space. [4 marks]

(iv) The ground-state eigenfunction for the harmonic oscillator in coordinate space is

$$\psi(x) = A \exp(-\alpha x^2/2)$$

where  $\alpha$  and  $A$  are constants. Explain why the ground-state eigenfunction in momentum space must have the form

$$\phi(p_x) = B \exp(-\beta p_x^2/2)$$

where  $B$  and  $\beta$  are constants.

[5 marks]

**2 (a)** When the intrinsic spin of the electron is taken into account, but with any interaction between the orbital angular momentum and the spin neglected, the Hamiltonian of the hydrogen atom is

$$H = H_{\text{usual}} + H_{\text{spin}}.$$

where  $H_{\text{usual}}$  is the regular hydrogen-atom Hamiltonian and  $H_{\text{spin}}$  is due to the interaction of the spin magnetic moment with applied magnetic fields.

(i) Explain why spin is described using matrices. [2 marks]

(ii) Show that when the magnetic field is not a function of the coordinates the solution of the time-independent Schrodinger equation is

$$\psi_{nlm m_s} = R_{nl}(r) Y_{lm}(\theta, \phi) \chi_{m_s}$$

where  $\chi_{m_s}$  is the solution of

$$H_{\text{spin}} \chi_{m_s} = \varepsilon_{\text{spin}} \chi_{m_s}$$

[6 marks]

(iii) The degeneracy of the energy levels in a hydrogen atom when electron spin is taken into account is  $2n^2$ , where  $n$  is the principal quantum number. Use this fact and the Pauli exclusion principle to explain the existence of electronic shells in atoms. [2 marks]

**(b)** Two of the Pauli spin matrices are

$$\sigma_x = \begin{pmatrix} 0 & 1 \\ 1 & 0 \end{pmatrix} \quad \text{and} \quad \sigma_y = \begin{pmatrix} 0 & -i \\ i & 0 \end{pmatrix}$$

The Hamiltonian of a certain electron in a uniform magnetic field  $B$  is

$$H = \frac{\mu_b}{\sqrt{2}} B (\sigma_x + \sigma_y)$$

where  $\mu_b$  is the Bohr magneton.

(i) Write down the time-independent Schrodinger equation for the electron [3 marks]

(ii) Calculate the energy eigenvalues and their corresponding eigenvectors. [10 marks]

(iii) Show that, as expected, the eigenvectors are orthogonal. [2 marks]

**3. (a)** A particle moves in a symmetrical two-dimensional box with walls placed at  $x = 0$ ,  $x = L$ ,  $y = 0$  and  $y = L$ . Hence its eigenfunctions are

$$\psi_{n_1 n_2}(x, y) = \sqrt{\frac{2}{L}} \sin \frac{n_1 \pi x}{L} \sin \frac{n_2 \pi y}{L}, \quad n_1, n_2 = 1, 2, 3, \dots$$

These are orthonormal, so that

$$\int_{x=0}^L \int_{y=0}^L \psi_{n_1 n_2}^* \psi_{n'_1 n'_2} dy dx = \delta_{n_1 n'_1} \delta_{n_2 n'_2}$$

(i) Show that the energy levels of the particle are given by

$$E_{n_1 n_2} = \frac{\hbar^2 \pi^2}{2mL^2} (n_1^2 + n_2^2) \quad n_1, n_2 = 1, 2, 3, \dots$$

[4 marks]

(ii) Explain why, apart from the ground-state energy, each of the energy levels is in general degenerate. [2 marks]

(iii) Explain why the first excited state is doubly degenerate. [2 marks]

If the particle is acted upon by the perturbation  $H' = k$ , where  $k$  is a constant, use perturbation theory to

(iv) obtain the first-order correction to the energy of the ground of the particle, [3 marks]

(v) obtain the first-order correction to the energy of the first excited state. [9 marks]

(vi) Explain why your results are in fact exact and why they must apply to all the states of the system. [3 marks]

(vii) Hence, deduce the eigenfunctions of the perturbed system. [2 marks]

4 (a) A system is acted upon by a time-dependent perturbation of the form

$$H' = h(\mathbf{r})e^{-i\Omega t}$$

(i) Show that such a system preferentially absorbs energy in units of  $\hbar\Omega$  as a result of this perturbation. [9 marks]

(ii) Explain how this result relates to the photoelectric effect. [4 marks]

(b) Three identical non-interacting fermions whose coordinates are  $x_1$ ,  $x_2$  and  $x_3$  are confined in a one-dimensional box of length  $L$ . The normalised single-particle states are

$$\psi_{n_i}(x_i) = \sqrt{\frac{2}{L}} \sin\left(\frac{n_i \pi x_i}{L}\right) \quad \text{with energies } E_{n_i} = \frac{\hbar^2 n_i^2 \pi^2}{2mL^2}, \text{ where } n_i = 1, 2, 3, \dots$$

(i) Prove that at  $T = 0$  the ground-state energy of the system is

$$E = \frac{7\hbar^2 \pi^2}{mL^2}$$

[3 marks]

(ii) Obtain the ground-state wave function of the system. [5 marks]

Suppose now that the particles are bosons instead.

(iii) Deduce what the ground-state energy is at  $T = 0$ . [2 marks]

(iv) Write down the corresponding ground-state wave function. [2 marks]

5. (a)(i) Explain the main advantage of the variational method over perturbation theory for calculating approximate energies and eigenfunctions of quantum systems. [2 marks]

(b) Show that the expression

$$\langle H \rangle = \frac{\int \phi^* H \phi d\tau}{\int \phi^* \phi d\tau}$$

is an upper limit to the ground-state energy of a system with Hamiltonian  $H$ . [5 marks]

(c) The harmonic-oscillator Hamiltonian is

$$H = \frac{p^2}{2m} + \frac{1}{2}kx^2$$

Since the wave function must be finite for any  $x$ , and must vanish as  $x \rightarrow \pm\infty$ , it seems reasonable to take as a trial function for the ground state of the oscillator the function

$$\phi(\alpha) = \exp(-\alpha x^2), \quad \alpha > 0.$$

- (i) Use the variational method to find the best value of  $\alpha$ . [12 marks]  
(ii) Obtain an estimate for the energy and the ground state. [4 marks]  
(iii) Comment on your result. [2 marks]

6. (a) The components of the angular momentum operator are

$$L_x = i\hbar(\sin\varphi \frac{\partial}{\partial\theta} + \cot\theta \cos\varphi \frac{\partial}{\partial\varphi}),$$

$$L_y = i\hbar(-\cos\varphi \frac{\partial}{\partial\theta} + \cot\theta \sin\varphi \frac{\partial}{\partial\varphi})$$

$$L_z = -i\hbar \frac{\partial}{\partial\varphi}$$

while the spherical harmonic for  $l = 2$ ,  $m = 0$  is

$$Y_{20}(\theta, \varphi) = \sqrt{\frac{5}{16\pi}}(3\cos^2\theta - 1)$$

- (i) Obtain the unnormalised spherical harmonics  $Y_{21}(\theta, \varphi)$  and  $Y_{2,-1}(\theta, \varphi)$ . [12 marks]  
(ii) Confirm that the functions found in (i) above are indeed eigenfunctions of  $L_z$ . [3 marks]

(b) The Hamiltonian for the harmonic oscillator is

$$H = \frac{p^2}{2m} + \frac{1}{2}m\omega^2 x^2$$

The ladder operators for the harmonic oscillator are

$$a_{\pm} = \frac{1}{\sqrt{2}} \left[ \frac{p}{(m\hbar\omega)^{1/2}} \pm i \left( \frac{m\omega}{\hbar} \right)^{1/2} x \right]$$

and are Hermitian conjugates of one another. The Hamiltonian can be written in terms of these operators as

$$H = \hbar\omega \left[ a_- a_+ - \frac{1}{2} \right]$$

These operators satisfy the commutation relations

$$[H, a_{\pm}] = \pm \hbar\omega a_{\pm}$$

The eigenfunction of  $H$  corresponding to the energy value  $E_n = (n + \frac{1}{2})\hbar\omega$  is denoted by  $|n\rangle$ .

- (i) Show that  $a_+$  is a raising operator. [4 marks]  
(iii) Hence prove that the eigenfunctions are given by

$$|n\rangle = \frac{1}{\sqrt{n!}} (a_+)^n |0\rangle$$

where  $|0\rangle$  is the ground-state eigenfunction. [6 marks]

\*\*\*\*\*END OF EXAMINATION\*\*\*\*\*