

**THE UNIVERSITY OF ZAMBIA  
SCHOOL OF MINES  
FIRST SEMESTER EXAMS- JUNE 2004**

1. GG 201 : INTRODUCTION TO GEOLOGY I
2. GG 201 : INTRODUCTION TO GEOLOGY II
3. GG 301 : PRINCIPLES OF GEOLOGY I
4. GG 301 : PRINCIPLES OF GEOLOGY II
5. GG 311 : CRYSTALLOGRAPHY AND OPTICAL MINERALOGY
6. GG 361 : ENGINEERING GEOLOGY (PAPER 1)
7. GG 361 : ENGINEERING GEOLOGY (PAPER 2)
8. GG 411 : IGNEOUS PETROLOGY
9. GG 421 : SEDIMENTOLOGY I
10. GG 421 : SEDIMENTOLOGY II
11. GG 435 : STRUCTURAL GEOLOGY AND PLATE TECTONICS I
12. GG 471 : GEOCHEMISTRY
13. GG 551 : EXPLORATION, MINING GEOLOGY AND MANAGEMENT
14. GG 561 : ENGINEERING GEOLOGY AND ROCK MECHANICS
15. MG 319 : I COMPUTER TECHNIQUES (THEORY)
16. MG 319 : I COMPUTER TECHNIQUES (PRACTICAL)
17. MI 209 : INTRODUCTION TO MINE DEVELOPMENT
18. MI 315 : ROCK MECHANICS 1
19. MI 431 : UNDERGROUND MINE DESIGN
20. MI 435 : SURFACE MINE DESIGN
21. MI 455 : OPERATIONS RESEARCH
22. MI 555 : MINING GEOSTATISTICS
23. MI 585 : MATERIALS HANDLING<sup>15</sup>
24. MM 321 : PHYSICAL METALLURGY I
25. MM 331 : CHEMICAL THERMODYNAMICS I
26. MM 411 : MINERAL PROCESSING I
27. MM 441 : PYROMETALLURGY
28. MM 451 : TRANSPORT PHENOMENA
29. MM 481 : FERROUS METALLURGY
30. MM 515 : SPECIAL TOPICS IN MINERAL PROCESSING
31. MM 545 : SELECTED TOPICS IN EXTRACTIVE METALLURGY
32. MM 571 : MINE ECONOMICS AND MANAGEMENT

THE UNIVERSITY OF ZAMBIA  
SCHOOL OF MINES

FIRST SEMESTER EXAMINATIONS – JUNE 2004

GG201 – INTRODUCTION TO GEOLOGY

PAPER I - THEORY

---

**INSTRUCTIONS:** Answer any five questions. Illustrate your answers wherever possible.  
**TIME:** Three (3) Hours

---

1. (a) The atmosphere and hydrosphere form the outer parts of planet Earth. How do you think these two zones formed at the formative stages of the Earth and what are the main constituents of each of the zones? (5 marks)
- (b) How does the process of photosynthesis contribute to the sustenance of the atmosphere and life? (2 marks)
- (c) Continental drift (continents are in constant motion) is one of the concepts that contributed to the unifying theory of plate tectonics. State and discuss briefly two pieces of evidence supporting continental drift. (4 marks)
- (d) State the three types of plate boundaries and describe geological activities associated with each boundary (9 marks)
  
2. (a) Define the following (6 marks):
  - (i) Proton
  - (ii) Neutron
  - (iii) Electron
  - (iv) Atomic number
  - (v) Atomic mass
  - (vi) Isotope
- (b) Distinguish covalent bonds from ionic bonds (4 marks).
- (c) With two mineral examples for each describe isomorphism and polymorphism. (5 marks)
- (d) Why is colour not a diagnostic physical property of a mineral? Give two mineral examples in which colour is so variant. (3 marks)
- (f) Density (or specific gravity) of a mineral is a function of two parameters. State these two parameters. (2 marks)
  
3. (a) If a rock that contains quartz, K-feldspar, muscovite and biotite had to be melted, would you expect it to melt all at once or not and why? List the minerals in order of their melting. (3 marks)
- (b) If you were mapping an area with a series of lava flows, how would you tell the top of one flow and bottom of the next younger flow? (2 marks)
- (c) Distinguish a sill from a dyke. (4 marks)
- (d) Describe the following briefly: (9 marks)
  - (i) Cross-bedding
  - (ii) Ripple marks
  - (ii) Graded-bedding
- (e) What sedimentary interpretations can one draw from cross-bedding and ripple marks. (2 marks)
  
4. (a) State the principle of original horizontality and the principle of superposition. (4 marks)
- (b) What are fossils? State two geological aspects in which fossils are employed. (2 marks)
- (c) Describe and discuss how the following are used in relative dating of geological events: (6 marks)

- (i) Layering
  - (ii) Unconformity
  - (iii) Cross cutting features
- (d) State three of the four commonly used radiometric dating methods giving for each the parent and daughter isotopes. (3 marks)
- (e) Give the limitations associated with radiometric dating methods. (5 marks)

5. (a) Describe briefly the following: (10 marks)
- (i) Normal fault
  - (ii) Horst
  - (iii) Joint
  - (iv) Monocline
  - (v) Anticline
- (b) What is 090/50oE in one word? State each of the parts reflected in this word. (2.5 marks)
- (c) What would you call a fault on which the following movements are evident: (1.5 marks)
- (i) Horizontal
  - (ii) Vertical
  - (iii) Both vertical and horizontal
- (d) Given that 4 drill holes have been drilled in a rectangular pattern of 500 m (A-B) x 1000 m (A-D). These drill holes have intersected a flat lying vein of copper sulphide over lengths and with average copper grades given in the table below. Determine the tonnage and average grade of the deposit. What is the reserve? (6 marks)

Drillhole No.	Length of intersection (m)	Average grade of Cu over the intersection length (%)	Minerals identified & density (kg/m <sup>3</sup> )
A	5.4	2.3	Chalcopyrite (4300), quartz (2700)
B	6.0	3.1	Bornite (3950), calcite (2880)
C	4.9	2.9	Chalcocite (4200), calcite (2880)
D	5.1	2.6	Chalcopyrite (4300), quartz (2700)

6. (a) What do you think is a hydrothermal solution? (2 marks)
- (b) State and describe three ways in which hydrothermal solutions are generated. (9 marks)
- (c) Distinguish between vein and disseminated deposits. (4 marks)
- (d) What is a placer deposit and how does it form? Give examples of minerals that would constitute such deposits and why? (5 marks)
7. (a) State any four negative impacts that copper/cobalt mining on the Zambian Copperbelt has imposed on the environment and indicate how each of these impacts may have been generated? (10 marks)
- (b) Suggest ways in which each of the environmental impacts in (a) may be remedied. (8 marks)
- (c) Stone crushers in Lusaka need to protect themselves against flying stone fragments, sharp stone edges and dust. Suggest three ways in which they may achieve this protection stating which parts of the body may need such protection. (2 marks)

-----Good Luck!!-----

**THE UNIVERSITY OF ZAMBIA  
SCHOOL OF MINES**

**FIRST SEMESTER EXAMINATIONS – JUNE 2004**

**GG201 – INTRODUCTION TO GEOLOGY**

**PAPER II - PRACTICAL**

---

**INSTRUCTIONS:** Answer all questions. Illustrate your answers wherever possible.  
**TIME:** Three (3) Hours

---

1. You are provided with mineral specimens A, B, C, & D. Using the following physical properties identify the minerals: colour, hardness, streak, cleavage/fracture, magnetism & reaction with acid. You are expected to describe the properties. (20 marks)
2. Rock specimens E, F, G & H have to be identified. Use the following physical properties to identify these rocks: colour, texture (grain size), structure (foliation – schistosity, gneissosity; bedding) or massive (without structure), mineralogy, reaction with acid, crystalline or not, sorting, roundness, & versicular or amygdaloidal. State with reasons whether the rock is igneous, sedimentary or metamorphic. (25 marks)
3. In a mining area a 4 m diameter drainage tunnel is to be driven horizontally and north-south into bedrock at an elevation of 500 m above sea level. The tunnel will pass directly under a point designated A. Three vertical drill holes are driven to locate a probable planar fracture. The location of the drill holes and altitude of the structure is given in the table below: (35 marks)

Drill Hole	Location	Altitude of structure
B	1000 m east of A	900 m
C	1000 m north of A	100 m
D	1200 m N300E of A	700 m

- (a) Draw to scale (1 cm:200 m) the representation of the situation above including the tunnel and well labeled strike lines.
- (b) Determine the strike, dip and dip direction of the structure.
- (c) Where, relative to A, will the tunnel cross the structure?
- (d) What would be the depth at which the tunnel is intersected if a vertical drill hole was sited at point A if it was 1100 m above sea level?

-----Good Luck!!-----

**UNIVERSITY OF ZAMBIA  
SCHOOL OF MINES**

**FIRST SEMESTER UNIVERSITY EXAMINATIONS – JUNE 2004**

**GG301 PRINCIPLES OF GEOLOGY II**

**PAPER I - THEORY**

---

**INSTRUCTIONS: ANSWER TWO QUESTIONS FROM SECTION A AND ONE QUESTION FROM SECTION B AND ANY OTHER TWO. USE ILLUSTRATIONS WHERE POSSIBLE**

**TIME: THREE HOURS**

---

**SECTION A - STRUCTURES**

- Q1. (a) What are secondary structures?  
(b) Describe two types of secondary structures and how they are formed.  
(c) Define strain  
(d) Describe in detail, two types of strain. Use diagrams to illustrate your answer.
- Q2. (a) What is stereographic projection?  
(b) Why is it important to construct stereograms?  
(c) How can a pole (point) representing a fault plane be plotted on a stereo net?
- Q3. ~~(a)~~ Define the following terms:  
(a) Hangingwall  
(b) Reverse fault  
(c) Hinge line  
(d) Foliation  
(e) Fold limb
- Q4. (a) Describe in detail, two types of shear. Use diagrams to illustrate your answer.  
(b) Discuss the three (3) successive stages of deformation that a rock passes through during increasing stress.
- Q5. Describe the process and the type of stresses responsible for the formation of:  
(a) Hosts and grabens  
(b) Half-grabens

## SECTION B – ECONOMIC GEOLOGY

- Q6. (a) Define the following terms:
- (i) Ore
  - (ii) Proven reserves
  - (iii) Cut-off-grade
  - (iv) Assay
  - (v) Tonnage
  - (vi) Orebody
  - (vii) Prospecting
  - (viii) Trenching
- (b) (i) State three important conditions required for the formation of any mineral deposits. Illustrate how these would apply to the formation of the copper sulphide deposits on the Zambian Copperbelt.
- (ii) Briefly describe how copper porphyry deposits form. State which tectonic boundaries such deposits are associated with and why?
- Q7. (a) Describe 4 negative environmental impacts caused by mining of copper and cobalt on the Zambian Copperbelt
- (b) What sort of mining activities produce impacts described in (a)?
- (c) How would such impacts be remedied?
- (d) Describe 2 environmental impacts related to minerals exploration, state the activities responsible for such impacts and how they may be remedied.

-----GOOD LUCK-----

UNIVERSITY OF ZAMBIA  
SCHOOL OF MINES

FIRST SEMESTER UNIVERSITY EXAMINATIONS – JUNE 2004

GG301 PRINCIPLES OF GEOLOGY II

PAPER II - PRACTICAL

-----  
INSTRUCTIONS: ANSWER ALL QUESTIONS

TIME: THREE HOURS  
-----

Q1. Construct poles to the following joint structures:

N025E/70SE; N080E/90; N045E/66SE; N060E/35SE; N112E/34NW; N100E/70NW;  
N090E/40SE; N032E/78SE; N360E/90

Note: All measurements are given as strike/dip and dip direction

Explain the distribution of the points on your stereonet

Q2. Given two pairs of planes as follows,

Pair 1: P1 = N010E/41NW and P2 = N305E/26SW;

Pair 2: Px = N350W/65NE and Py = N049W/42SE

Determine:

- The angle between each pair of planes
- The direction and plunge of the line of intersection in each pair of planes

Use a separate diagram for each pair.

Q.3 Study the following diagram.

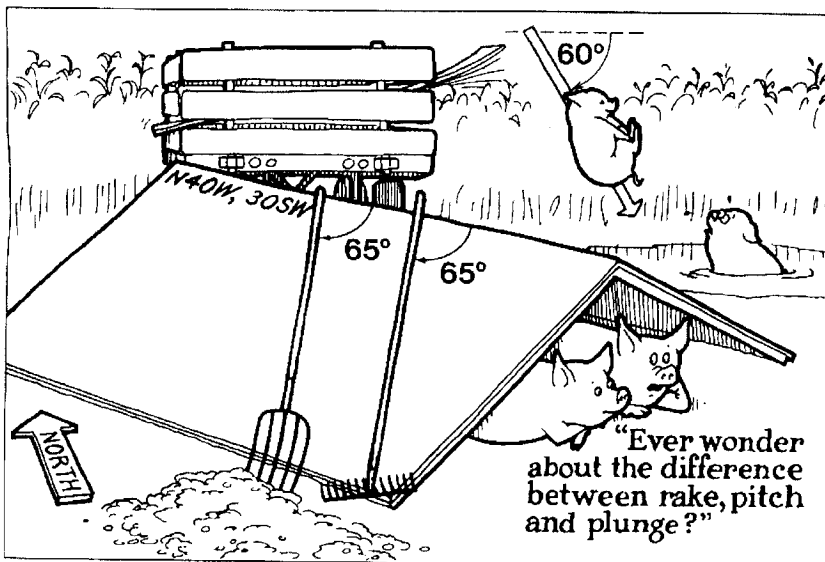

The left side of the roof strikes N40W and dips 30SW. After a hard day's work, a Gardener takes a rest and leaves his rake and fork as shown above. Find the direction and plunge of the rake.

Q4. The figure below shows a geological map. Construct cross sections along the following lines:

- a) A-B
- b) X-Y

Use a separate sheet for each cross section

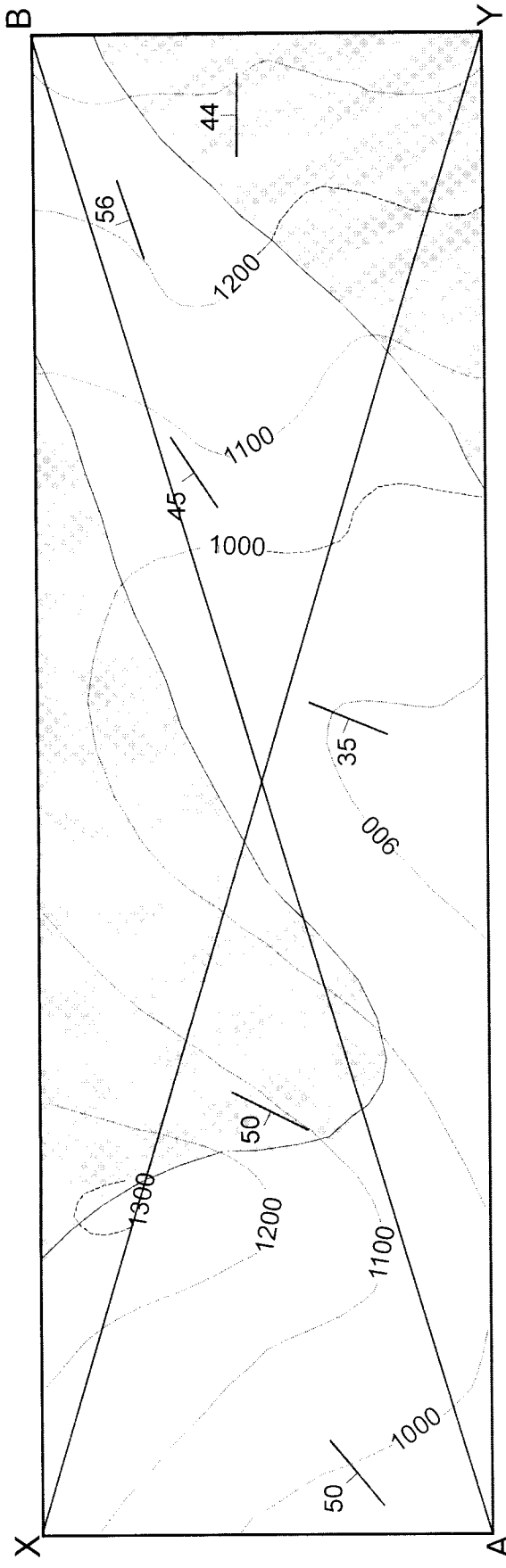

Geological Map for Question 4

THE UNIVERSITY OF ZAMBIA  
SCHOOL OF MINES

FIRST SEMESTER UNIVERSITY EXAMINATIONS – JUNE 2004

GG311 – CRYSTALLOGRAPHY AND OPTICAL MINERALOGY

PAPER I - THEORY

---

**INSTRUCTIONS:** Answer any five questions illustrating your answers wherever possible.

**TIME:** Three (3) Hours

---

1. (a) Describe the main types of chemical bonds that bind atoms together.  
(b) State Pauling's rules and discuss the meaning of each one of them.  
(c) Why is it important to understand the different types of chemical bonds in the study of mineralogy.
  
2. (a) Define the following terms and concepts.  
(i) Isomorphism  
(ii) Polymorphism  
(iii) Solid solution  
(iv) Coupled substitution  
(b) Given the following chemical analysis of olivine, calculate the chemical formula of the mineral and state its Fa and Fo content.  
MgO 6.23%; FeO 62.86%; SiO<sub>2</sub> 30.91%
  
3. (a) Define the following:  
(i) Unit cell  
(ii) Crystal Lattice  
(iii) Plane of symmetry  
(iv) Rotational axis  
(b) State the Law of Constancy of Interfacial Angles. What is the significance of this law?  
(c) State the Law of Rational Ratios of Intercepts. What is the significance of this law?
  
4. (a) To which structural class does each of the following minerals belong?  
(i) Jadeite: NaAlSi<sub>2</sub>O<sub>6</sub>  
(ii) Nepheline: NaAlSiO<sub>4</sub>  
(iii) Kyanite: Al<sub>2</sub>SiO<sub>5</sub>  
(iv) Quartz: SiO<sub>2</sub>  
(v) Beryl: Be<sub>3</sub>Al<sub>2</sub>Si<sub>6</sub>O<sub>18</sub>  
(b) Using appropriate diagrams, describe the structures of the amphibole and mica groups.

5. (a) To which structural groups does each of the following carbonate minerals belong?
- (i) Dolomite:  $\text{CaMg}(\text{CO}_3)_2$
  - (ii) Calcite:  $\text{CaCO}_3$
  - (iii) Aragonite:  $\text{CaCO}_3$
  - (iv) Malachite:  $\text{Cu}_2(\text{OH})_2\text{CO}_3$
- (b) Using appropriate diagrams, describe the structure and occurrence of the calcite and aragonite groups.
6. Describe the following terms:
- (a) Relief
  - (b) Pleochroism
7. (a) What is birefringence and what type of minerals exhibit it?
- (b) What is an optical indicatrix?

-----Good Luck!!-----

**THE UNIVERSITY OF ZAMBIA**  
**UNIVERSITY EXAMINATIONS – JUNE 2004**  
**GG 361 - ENGINEERING GEOLOGY**  
**PAPER I – THEORY**

**TIME:** THREE HOURS

**ANSWER:** ANY 5 QUESTIONS. ALL QUESTIONS CARRY EQUAL MARKS

- 1 a) Give the empirical formula of Coulomb's law and describe the quantities involved.
- b) What is the difference between the properties of materials and the properties of mass with regard to both soils and rocks? Why is there a difference? Why is the difference of importance in engineering geology?
- c) Geologic materials may be classified into three main groups on the basis of shear strength parameters. Illustrate, with the aid of diagrams, these three main categories of geologic materials
- 2 a) Site investigations are usually carried out in stages, with each stage building up enough information to allow execution of the next.
  - i) Mention two aims of a site investigation.
  - ii) Briefly describe the different stages involved
- b) During an in-situ test to determine deformation characteristics of a foundation ground, a rockmass with a circular cross-sectional area, with a diameter of 1.5 m, was subjected to a load of 300 kNm<sup>-2</sup>. If the mass experienced a change of 15 cm in its original length of 3 m and 7.5 cm in its diameter, calculate the:
  - i) Longitudinal and diametrical strains
  - ii) Poisson's ratio, and
  - iii) Modulus of elasticity.
- 3 a) After the construction of Block 1 of the Kalingalinga Hall of residence, it was discovered that there was a discontinuity inclined at 30° underlying the structure. It was determined that the structure imposed a stress ( $\sigma_1$ ) of 700 kNm<sup>-2</sup>. If, as a result of this stress, the structure induced a horizontal stress ( $\sigma_3$ ) of 300 kNm<sup>-2</sup>, determine the normal and shear stresses that acted on the discontinuity surface.

If shear box tests of this discontinuity gave the following results:

Normal ( $\sigma_n$ ) stress (KNm <sup>-2</sup> )	50	100	200	300
Shear ( $\tau$ ) stress (KNm <sup>-2</sup> )	36	86	154	235

From the normal and shear stresses determined in (a), would the structure fail along this plane? Explain your answer.

- 4 a) (i) Describe the three major classes of rocks.  
 (ii) What criteria are used to categorise them into these three classes.  
 (iii) List two common rock types in each of the three main classes of rocks
- b) Rocks that originate from solidification of molten magma occur either as extrusive or intrusive bodies. Describe/explain:
  - (i) The main mode of occurrence of each group.
  - (ii) How and why textures of these two groups of rocks differ.
- c) Make a table with two columns. In the left column, list four major intrusive rocks. In the right column, list their extrusive equivalents.

- 5
  - a) Describe the components of the hydrologic cycle.
  - b) Using some component(s) of the hydrologic cycle, describe a situation that would lead to flooding of an area.
  - c) Define permeability and state three features that influence the permeability of a geologic body
  - d) Permeability in the laboratory is determined by the use of permeameters. On such permeameter in the School of Mines has a diameter of 75 mm and is 0.15 m long. The diameter of the stand-pipe is 1.5 cm. During the test, the head decreases from 1.3 m to 80 cm in 2.25 minutes. Calculate the coefficient of permeability of the sample in mm/s.
- 6
  - a) How would you define the term 'water pollution'?
  - b) Describe any engineering and/or human activities that are likely to be responsible for groundwater pollution in the Lusaka aquifer.
  - c) The Public Health Department at the Lusaka City Council is looking for a site for the disposal of waste, which consists of domestic, industrial and clinical hazardous waste. Describe the geological, hydrogeological and geotechnical parameters that you would consider in the location of this site.
- 7 Write short notes on the following:
  - a) Anticline and Syncline and how they are formed
  - b) The three types of fold shapes
  - c) Three major types of discontinuities and their significance in engineering practice.
  - d) The four main factors that cause and control metamorphism.
  - e) Why there are so many silicate minerals in the Earth's crust.
  - f) The difference between porosity and permeability. Can soil or rock be porous or permeable? Explain your answer.

\_\_\_\_\_END OF EXAMINATION. GOOD LUCK!\_\_\_\_\_

**THE UNIVERSITY OF ZAMBIA**  
**UNIVERSITY EXAMINATIONS – JUNE 2004**  
**GG 361 - ENGINEERING GEOLOGY**  
**PAPER II - PRACTICAL**

**TIME:** THREE HOURS

**ANSWER:** ALL QUESTIONS

---

1. During a site investigation for a prospective construction site, the Geology Department provided you with a map showing different geological formations as shown in Map 1. For this Map:
  - a) Determine the dip of the strata
  - b) Draw a topographic profile and geologic section along the line AB to get an idea of the relationships of the different lithologies.
  
2. Map 2 depicts a land surface contoured at 5 m intervals from which Ranking Engineering Consultants would like to win sandstone and limestone for construction purposes. Outcrop locations of these beds' boundaries and of a mudstone are marked on the map, where the base of a sandstone outcrops at A, the base of a limestone outcrops at B, and the base of a mudstone at C. Assuming that between A and B only sandstone is present, between Band C only limestone is present and that only mudstone is present in the succession above C:
  - i) Complete the outcrops of the bed boundaries.
  - ii) Shade the lithologies as appropriate.
  - iii) Indicate the depths at which sandstone and limestone would be intersected at point C.

Note The rate of true dip of the beds is 1 in 10 on a bearing of 210°
  
3. The Lusaka Water and sewerage Company has contracted you to explore for new sources of water to augment supply to the city of Lusaka. Map 3 shows part of the aquifer in which water is coming out at A, Band C. For this area:
  - i) Indicate the probable location of the remainder of the aquifer outcrop on the map.
  - ii) Shade the area underlain by the aquifer, which you would recommend ~~to~~ for further drilling and exploitation

---

---

END OF EXAMINATION. GOOD L UCK!!!

Map 1

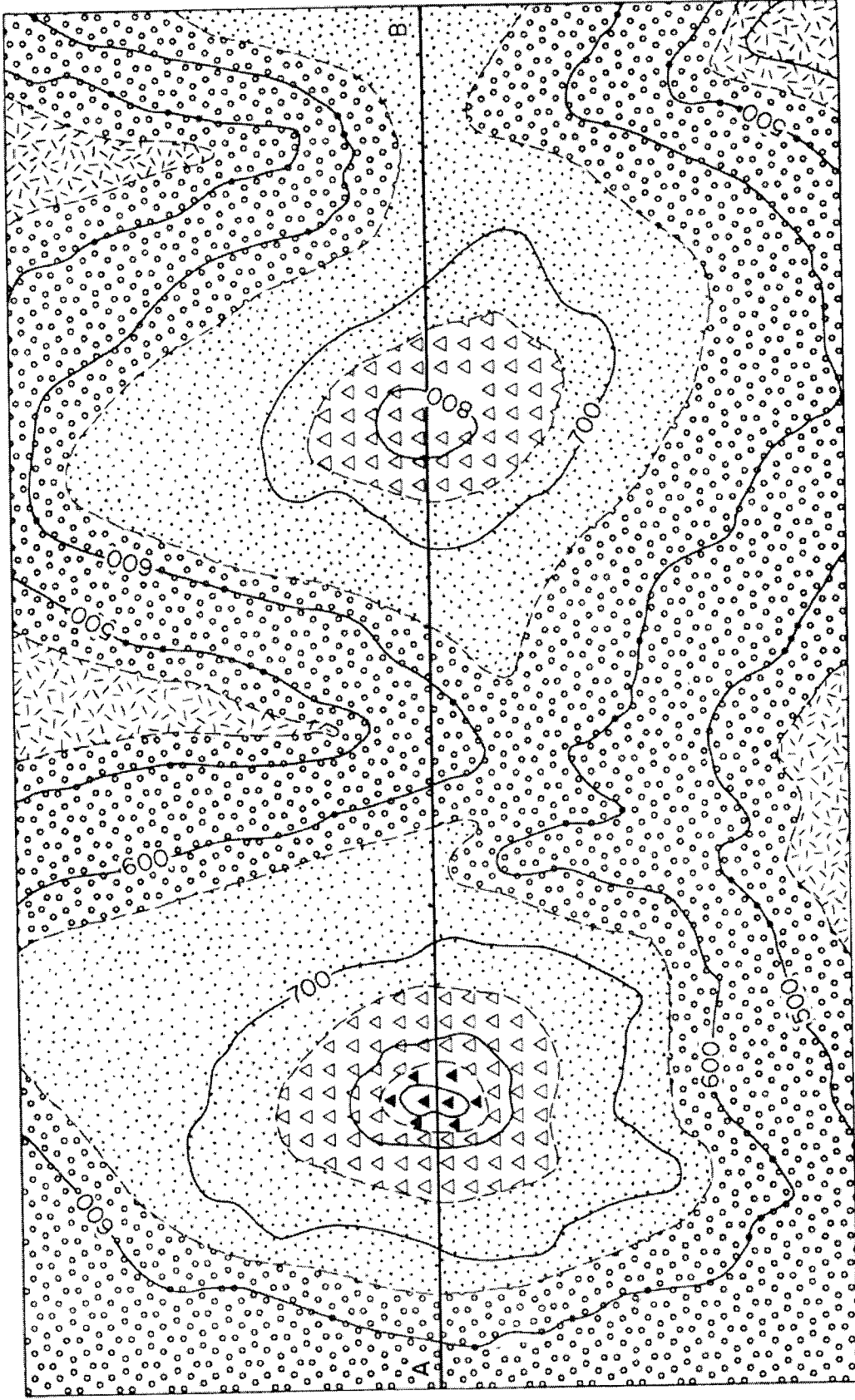

Scale in Metres  
0 500

Scale of feet

700 Topographic contours in metres  
--- Geologic contours

**Map 2**

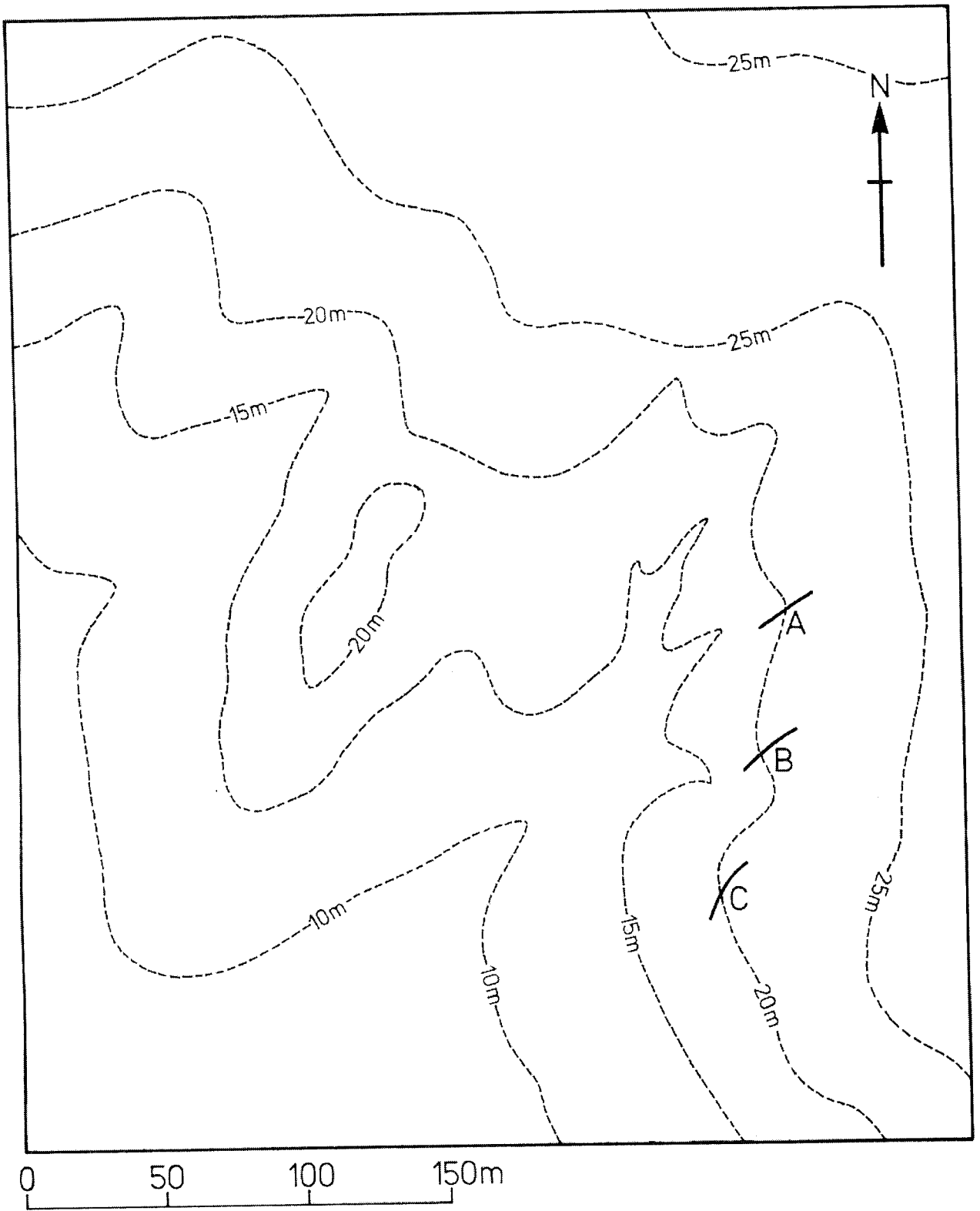

**Map 3**

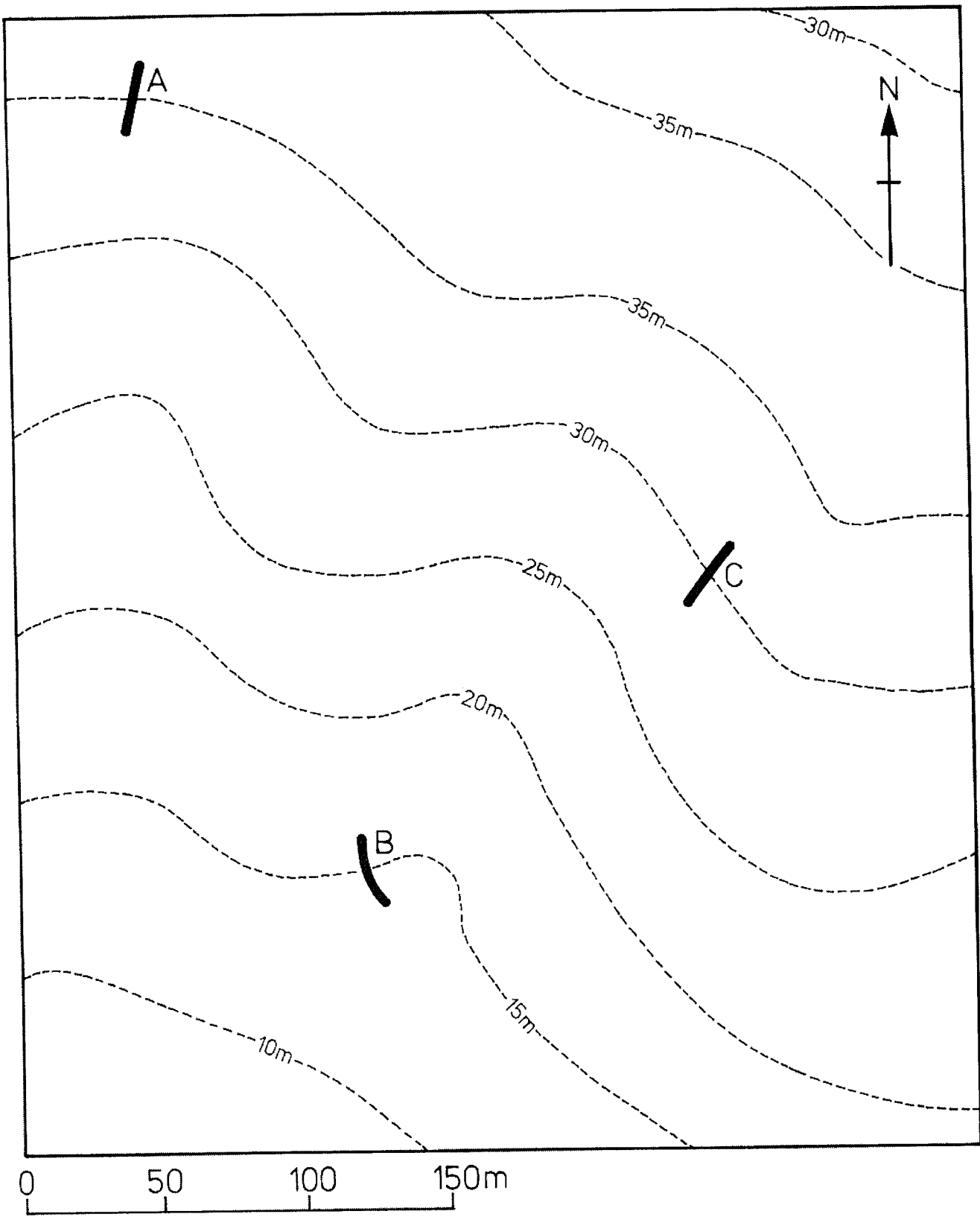

THE UNIVERSITY OF ZAMBIA  
SCHOOL OF MINES

FIRST SEMESTER UNIVERSITY EXAMINATIONS – JUNE 2004  
GG411 – IGNEOUS PETROLOGY

PAPER I - THEORY

---

**INSTRUCTIONS:** Answer questions 1 and 2 and any other 3 illustrating your answers wherever possible.

**TIME:** Three (3) Hours

---

1.
  - (a) What is the difference between magma and lava? Give two types of lava and their coarse-grained equivalents.
  - (b) A ropy lava (pahoehoe) is often seen to pass into a so called aa lava. Explain this feature.
  - (c) Explain the difference between hypersolvus and subsolvus granites.
  
2. Figure 1 is an illustration of the binary system MgO-SiO<sub>2</sub> at P = 1 atm.
  - (a) Describe the crystallization of liquid A, assuming equilibrium conditions. What is the mineralogy of liquid A?
  - (c) Discuss the mineralogical and chemical differences that would result the removal of olivine from liquid A during its crystallization.
  
3. Define and discuss briefly the following:
  - (a) Asthenosphere
  - (c) Perthitic intergrowth
  - (d) Normative composition
  
4. Give the main classification of volcanic rocks based on their tectonic environment associated with their eruptions.
  
5. Compare and contrast between the following:
  - (a) Liquidus and solidus lines used in phase diagrams
  - (b) Intergranular texture and intersertal texture
  - (c) Phacolith and laccolith
  
6. Give the sequence of layers that constitute the oceanic crust. Illustrate your answer with a geological cross-section. Where would it be possible to study the oceanic crust at the earth's surface?
  
7. With the aid of diagrams define the following:
  - (a) Liquid immiscibility
  - (b) Incongruent melting
  - (c) Incompatible minerals

-----Good Luck!!-----

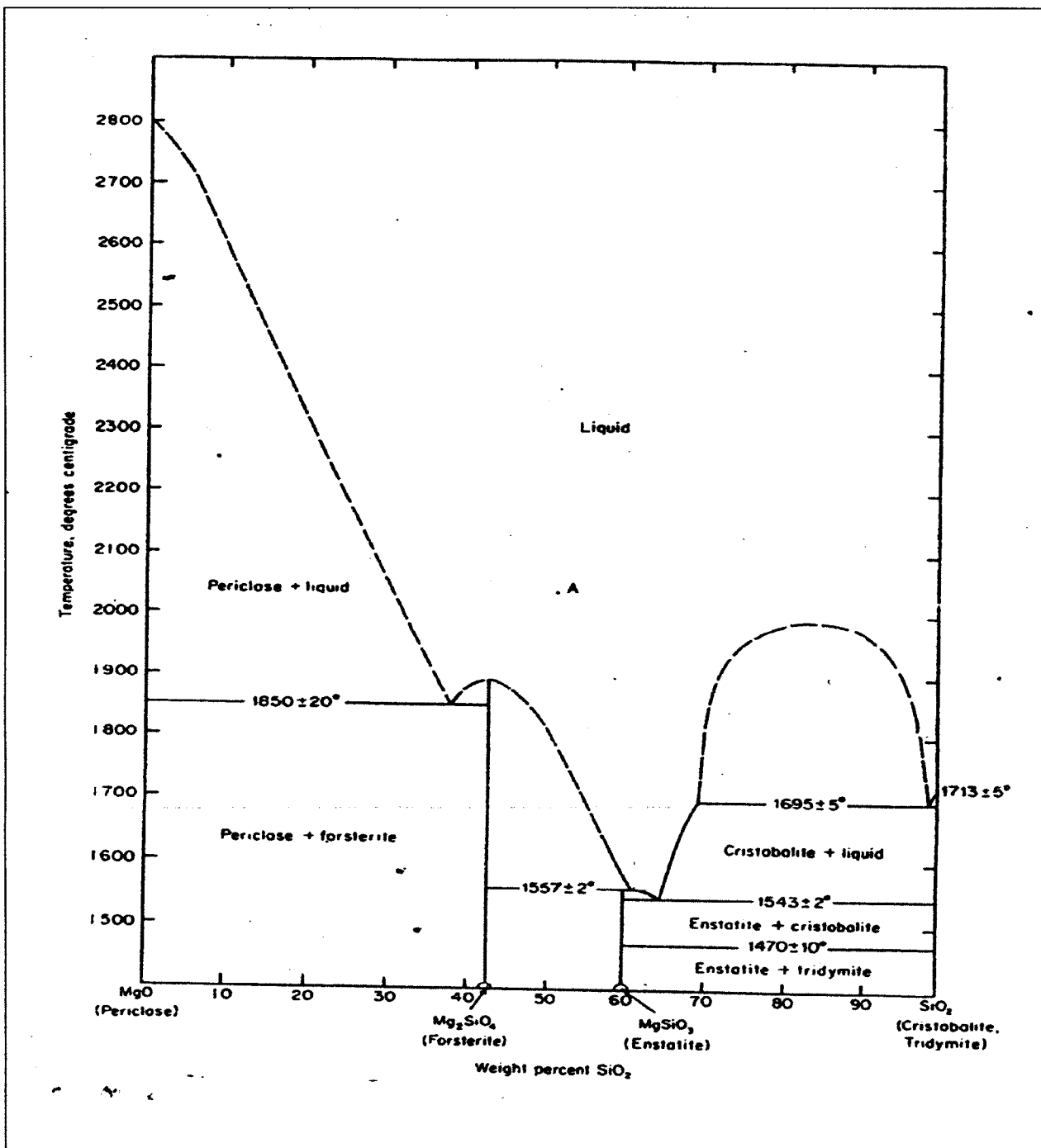

**Figure 1**

THE UNIVERSITY OF ZAMBIA  
SCHOOL OF MINES

FIRST SEMESTER UNIVERSITY EXAMINATIONS – JUNE 2004

GG411 – IGNEOUS PETROLOGY

PAPER II - PRACTICAL

---

**INSTRUCTIONS:** Answer all questions illustrating your answers wherever possible.

**TIME:** Three (3) Hours

---

1. Thin Section A (40 marks):
  - (a) Describe in full all the minerals.
  - (b) Estimate their modal percentages.
  - (c) Classify the rock according to the IUGS system.
  
2. Thin Section B (30 marks):
  - (a) Identify all the minerals present.
  - (b) Describe and discuss the texture of the rock.
  - (c) Is this a volcanic or a plutonic rock? Why?
  - (d) Name the rock.
  
3. Describe the equilibrium crystallization of Liquid L in Figure 1 (30 marks).

-----Good Luck!!-----

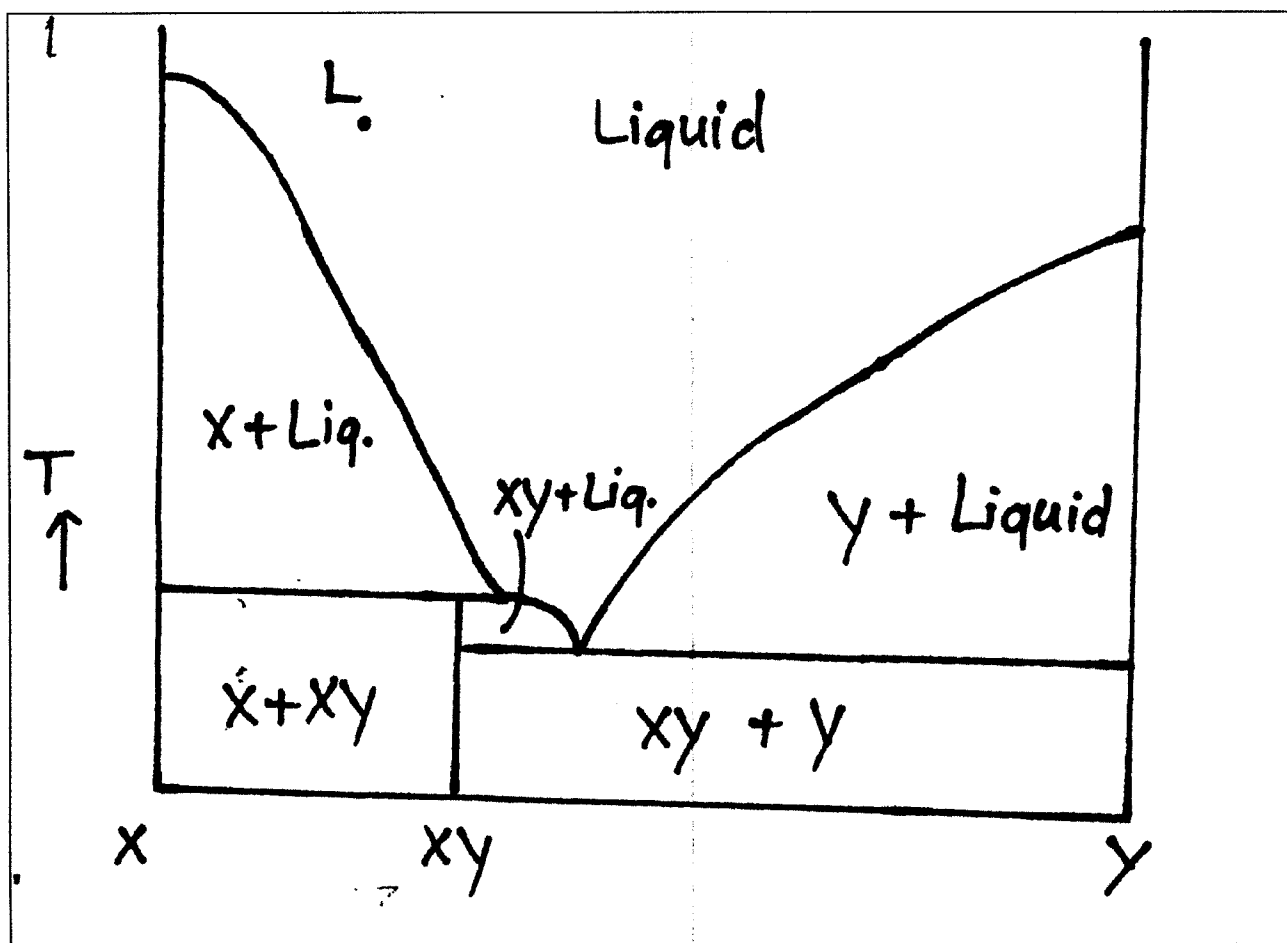

**Figure 1**

**THE UNIVERSITY OF ZAMBIA**  
**SCHOOL OF MINES**

**FIRST SEMESTER UNIVERSITY EXAMINATIONS – JUNE 2004**

**GG421: SEDIMENTOLOGY**

**PAPER I – THEORY**

**TIME:** THREE (3) HOURS

**INSTRUCTIONS:** ANSWER ANY 5 QUESTIONS. EACH QUESTION CARRY EQUAL MARKS. WELL – LABELLED SKETCHES & DIAGRAMS ARE REQUIRED FOR A FULL MARK

---

1. Distinguish between the following:

- (a) Desiccation cracks and syneresis cracks. Indicate depositional environment in each case.
- (b) Transgression and Regression
- (c) Sediment and Sedimentary Rock
- (d) Bed load and Suspended load
- (e) Loess and Volcanic ash

2. (a) Various structures can develop in water-saturated sediment deposited in unstable settings or configurations: Define five of these structures.
- (b) For fieldwork, outline how you could subdivide beds and laminae according to their thicknesses.
- (c) Using well-labeled diagrams, outline Dunham (1962) classification of carbonates.
3. (a) With an aid of a Table differentiate between braided and meandering river systems.
- (b) Define the term “Depositional Environment”. List the elements that characterize the physical and biological environments.
- (c) Sedimentary Environments are divided into three (3) broad categories. In each category, list the various sub-environments.
4. (a) The principal application of sedimentary structures is in the interpretation of sedimentary environments and this can be done at two levels. Briefly describe these TWO levels.
- (b) In the study of depositional environments, modeling of depositional systems is important. Outline the common elements you would consider in developing a model of Peritidal Systems (tide dominated lagoons & tidal flats).
- (c) Outline the organic processes that play an important role in lake sedimentation.

5. (a) How are sedimentary basins commonly classified? List the six basic sedimentary basin types as classified by Mitchell and Reading (1986).  
(b) Briefly describe the techniques used in Basin Analysis.  
(c) Outline two applications of Basin Analysis.
  
6. (a) In carbonates, the fundamental depositional system is the carbonate platform, sometimes called "Carbonate Factory". Describe briefly the three general types of carbonate platforms.  
(b) The geological record is characterized by several major episodes in which large reef structures and smaller reef mounds were formed and intervening periods when only the smaller reef mounds were formed. Indicate in a stratigraphic format the major "Reef Builders" in the geological record.  
(c) Outline the stages of reef growth (vertical zonation) indicating the resulting carbonate rock types at each stage.
  
7. Briefly define the following terms:
  - (i) Texture indicating the 5 grain properties included in the definition.
  - (ii) Facies Models.
  - (iii) Compositional maturity.
  - (iv) Micrite.
  - (v) Roundness.

GOOD LUCK

END OF EXAM

**THE UNIVERSITY OF ZAMBIA**

**FIRST SEMESTER UNIVERSITY EXAMINATION – JUNE 2004**

**GG421: SEDIMENTOLOGY**

**PAPER II – PRACTICAL**

**TIME:** THREE (3) HOURS

**INSTRUCTIONS:** ANSWER ALL QUESTIONS. SKETCHES AND DIAGRAMS ARE IMPORTANT FOR A FULL MARK

---

1. Figure 1 provided show stations (A – D) where you had taken palaeocurrent measurements in trough cross-bedded, nearly horizontal Mbala Formation Sandstone of the Mporokoso Group, Northern Province, Zambia. The following are the measurements in degrees you recorded at the four (A-D) stations (Fig. 1).

<b>Station A</b>	<b>Station B</b>	<b>Station C</b>	<b>Station D</b>
225	281	327	322
270	233	306	350
300	241	347	358
275	278	317	010
275	270	345	360
280	245	320	005
265	275	350	300
285	265	350	350
290	300	325	295
255	315	345	270

**Questions**

- (i) You are required to construct rose diagram to represent the palaeocurrent distribution and indicate these on Fig. 1
- (ii) Discuss the distribution of the palaeocurrent  
-----42 marks
2. During the same independent mapping in the Mbala Formation, Northern Province, you collected three hand specimens and made three corresponding thin sections. Your supervisor requires you to do the following:
- (a) To describe the three hand specimens (A – C) and thin sections (A – C) providing full mineralogy structures, features & provenance.....33 marks
- (b) Classify the rocks in 3(a) using appropriate classification procedures.....5 marks

- (c) Considering that hand specimen A came from the oldest unit with thickness of 30 cm, B from middle unit with thickness of 70 cm and C the youngest in a unit of 100 cm; draw a vertical profile indicating changes in facies.....12 marks
- (d) From the profile in 3(c) and your work in 3(a) & (b) comment and state the possible depositional environment for each rock and the overall sequence exhibited by the profile.....8 marks

GOOD LUCK

END OF EXAM

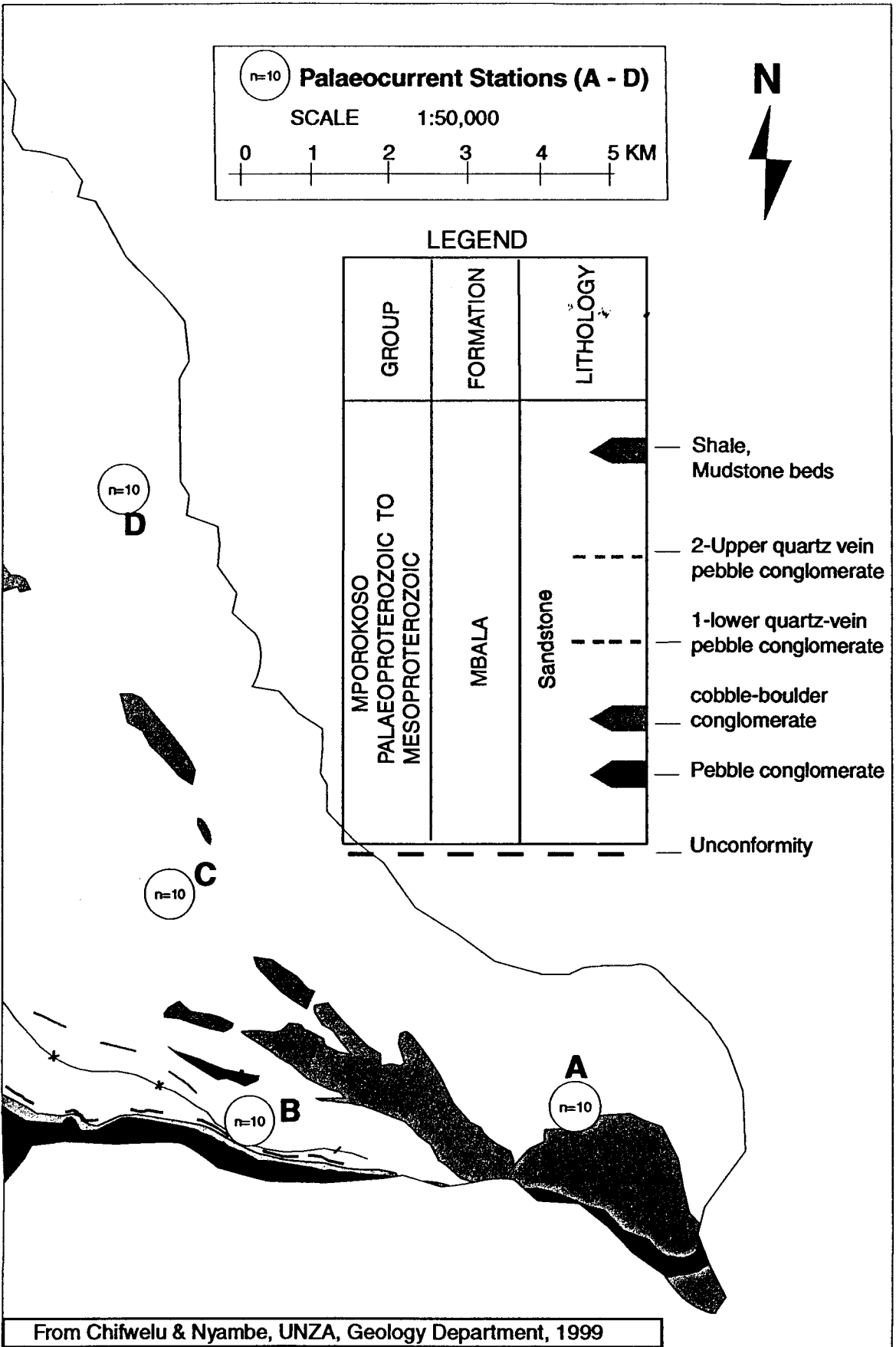

From Chifwelu & Nyambe, UNZA, Geology Department, 1999

**Figure 1**

THE UNIVERSITY OF ZAMBIA  
SCHOOL OF MINES

FIRST SEMESTER UNIVERSITY EXAMINATIONS – JUNE 2004 , 2<sup>3rd</sup>

GG 435 - STRUCTURAL GEOLOGY AND PLATE TECTONICS  
PAPER I - THEORY

---

**INSTRUCTIONS:** Answer any five questions. Give sketches wherever possible.

**TIME:** Three (3) Hours

---

Question 1 (20 Marks)

Define the following terms:

- (a) Sinistral transform fault
- (b) [0001] fabric
- (c) Island arc
- (d) 'Movement plane'
- (e) Foreland basin

Question 2 (20 Marks)

As a structural geologist, what do you understand by the term porphyroclast? Explain in detail how porphyroclasts can be used in the structural analyses of tectonites?

Question 3 (20 Marks)

Explain the structure of boudins and explain their formation in terms of rheology.

Question 4 (20 Marks)

Given that  $\tau_{xy}$ : 5.2kbars,  $\sigma_x$ : 11.05kbars, and  $\sigma_y$ : 5.03kbars do the following:

- (a) Calculate the principal stresses. (10 Marks)
- (b) Determine the angles between the principal stresses and the plane. (6 Marks)
- (c) Draw the Mohr circle. (4 Marks)

Question 5 (20 Marks)

- (a) What are the five (5) features that define L-tectonites? (10 Marks)
- (b) Describe the five (5) methods used in determining finite strain in deformed rock bodies. (10 Marks)

Question 6 (20 Marks)

Describe in detail how the extension of the Earth's crust can be accommodated in terms of plate tectonics.

*Good luck!*

**THE UNIVERSITY OF ZAMBIA  
SCHOOL OF MINES**

**FIRST SEMESTER UNIVERSITY EXAMINATIONS – JUNE 2004**

**GG471 – GEOCHEMISTRY**

---

**INSTRUCTIONS:** Answer any five questions illustrate your answers wherever possible. Questions carry equal marks.

**TIME:** Three (3) Hours

---

1.
  - (a) Describe the petrological and geochemical characteristics of the main meteorite types.
  - (b) On what basis are the different meteorite types classified?
  - (c) Discuss the significance of meteorites in relation to the origin of the solar system.
  
2.
  - (a) List the significant features of the solar abundances of the chemical elements
  - (b) What conclusion can you draw from these features?
  - (c) Give reasons why elements heavier than the Fe-group elements are not produced by nuclear fusion.
  - (d) With the help of diagrams, show how elements heavier than the Fe-group elements are produced.
  
3.
  - (a) Write down the equations for the velocities of the seismic body waves, explaining all the terms.
  - (b) Draw a cross-section of the structure of the earth and discuss the basis of using seismic body waves to determine the structure of the earth.
  - (c) How is the density distribution within the earth determined?
  - (d) Why are carbonaceous chondrites important in models of planetary accretion?
  
4.
  - (a) Discuss the factors that controlled the distribution of the elements during the formation of the earth's layered structure.
  - (b) Give the geochemical classification of the elements stating examples for each group.
  - (c) How is this classification related to the electronegativity of the elements and how does it relate to the periodic table?
  
5.
  - (a) Discuss how the composition of the upper mantle is obtained
  - (b) From your discussion above, write down the average composition of the upper mantle.
  
6.
  - (a) Discuss the main properties of silicate minerals.
  - (b) Write down the different structural types of silicates.

- (c) Why are silicates important in the study of magmatic processes?
  - (d) What do you understand by the term polymerization?
- 7.
- (a) When an atom of U-238 decays by emitting an alpha particle, what new isotope forms?
  - (b) When an atom of Th-234 decays by emitting a beta particle, what new isotope forms?
  - (c) Why is zircon the most commonly dated mineral when using the U-Pb system?
  - (d) Minerals from an igneous rock give the following values of Rb-87 and Sr-87 isotopes:

Mineral	$^{87}\text{Rb}/^{86}\text{Sr}$	$^{87}\text{Sr}/^{86}\text{Sr}$
Biotite	4.5	0.92
Muscovite	3.4	0.86
Microcline	2.1	0.79

-----Good Luck!!-----

**THE UNIVERSITY OF ZAMBIA  
SCHOOL OF MINES**

**FIRST SEMESTER EXAMINATIONS – JUNE 2004**

**GG551 – EXPLORATION, MINING GEOLOGY AND MANAGEMENT**

**INSTRUCTIONS:** Answer one question from each section and any other three.  
Illustrate your answers wherever possible.

**TIME:** Three (3) Hours

**SECTION A – EXPLORATION**

1. Suppose you were an exploration geologist hired by an international exploration organization which has decided to look for copper, lead, and zinc sulphide mineralization in a 60,000 km<sup>2</sup> area in eastern Zambia. In this area outcrops are very scanty. Describe with justifications the stages that you would propose to this organization to undertake for exploration in such an area cost effectively. Any methods suggested should be justified. (20 marks)
  
2. Earlier exploration undertaken by a certain firm over an area of 70,000 km<sup>2</sup> in Mbala District revealed anomalies of Cu, Zn, Ni and Au in stream sediments. Further preliminary investigations showed that there were fragments of pentlandite, pyrrhotite, uraninite, gold and chalcopyrite among the stream sediments pointing to the possibility of vein mineralisation in an area of 70 km<sup>2</sup>. This area was sold to another firm because it was considered too small. From the many ground methods you know and with reasons select five that would effectively be useful and describe them briefly. (20 marks)

**SECTION B – MINING GEOLOGY**

3. (a) Briefly explain what bias sampling is. (2 marks)  
(b) Briefly describe the following: (12 marks)
  - (i) Channel sampling
  - (ii) Grab sampling
  - (iii) Placer sampling
  - (iv) Bulk sampling
- (c) Discuss the advantages and disadvantages of drill core and drill cuttings sampling methods. (4 marks)
- (d) What is the importance of keeping sampling records? (2 marks)
4. (a) Define the terms grade and tonnage. (2 marks)  
(b) An orebody has been channel sampled and assay values determined as presented in the table below. Calculate the unweighted arithmetic average assay for both Cu and Co. If the orebody contains chalcopyrite (SG = 4.30), cobaltite (SG = 6.20),

and quartz (SG = 2.70), determine the modified average assay. Show clearly how you get to the values. (12 marks)

Channel Sample No.	Width (m)	Cu (%)	Co (%)
1	0.5	2.1	0.84
2	0.7	4.8	1.11
3	1.2	3.7	0.78
4	0.8	2.6	1.03
5	0.5	4.2	0.93
6	0.9	3.5	1.12
7	1.1	2.9	0.71
8	1.0	3.1	1.10
9	0.6	4.5	0.90
10	0.7	3.8	0.91

- (c) There are seven pieces of information required in the calculation of grade and tonnage. State six of these. (6 marks)

### SECTION C – ENVIRONMENT AND MANAGEMENT

5. Old mining operations frequently dumped wastes without concern for their physical or chemical stability or used milling and smelting techniques that released pollutants into the atmosphere or in public rivers and streams such as on the Zambian Copperbelt.
- In form of a Table show how such a mining economy was de-linked from the environment.
  - In a separate Table show how the old thinking in (a) above is currently being replaced by the new thinking (new economy).
6. Mining has been taking place on the Zambian Copperbelt for over 75 years now. Pollution of the environment has been blamed on this mining.
- Briefly outline the sources of anthropogenic contamination on the Copperbelt.
  - In Mufulira Mine area, cobalt concentration is high in surface soils but low or absent in the sub-surface soils. This phenomenon can be explained by surface versus sub-surface soil concept. Use this concept to explain the distribution of cobalt observed above in the soils of Mufulira.
  - Outline the recommendations you would give to the management of the mining companies on the Copperbelt so as to reduce the impact of mining on the environment.

-----Good Luck!!-----

**THE UNIVERSITY OF ZAMBIA  
SCHOOL OF MINES**

**FIRST SEMESTER UNIVERSITY EXAMINATIONS – JUNE 2004**

**GG 561 ENGINEERING GEOLOGY AND ROCK MECHANICS**

**ANSWER:** ANY FIVE QUESTIONS. ALL QUESTIONS CARRY EQUAL MARKS  
**TIME:** THREE HOURS

---

- 1 (a) What do you understand by the term "Groundwater Quality?"  
 (b) Describe any engineering and other human activities that are likely to degrade the quality of groundwater in Lusaka.  
 (c) Discuss the implications of repeated calls from Lusaka residents to transform the Blue Water Dam into a recreation Centre.  
 (d) Describe engineering geological parameters that should be considered in the siting of dumpsites in Lusaka
- 2 The residents of Handsworth Court have requested the Lusaka City Council to assist them build an underground car park to avert the rampant thieving of cars at night. A prospective site has been identified in front of the Vice Chancellor's Lodge. A 20 – metre borehole drilled at the site to ascertain ground conditions intersected nine metres of soil with the remainder being in rock. The portion that intersected rock gave the following drilled lengths in cms:

11.8	1.3	3.0	5.3	17.0	3.8	2.5	9.0	95.3	5.0	5.0	2.8	5.3
8.0	36.0	10.8	110	3.3	5.0	19.4	2.3	3.3	7.3	10.3	7.8	10.5
3.0	4.3	8.2	53.1	7.0	11.0	59.0	8.0	6.5	7.5	5.5	6.5	7.0
20.0	12.3	2.8	5.8	13.8	3.0	87.9	10.8	16.0	7.3	10.5	7.9	12.3

Determine for this drill hole:

- i) The core loss
- ii) The Rock Quality Designation (RQD)
- iii) Total Core Recovery (TCR)

How would you describe the quality of the rock intersected by the drill hole? Justify your answer.

- 3 (a) (i) Give the empirical formula of Coulumb's Law and describe all quantities involved.  
 (ii) Illustrate, with the aid of diagrams, the three main categories of geologic materials based on their shear strength parameters.
- (b) In the site mentioned in Question (2), two major discontinuities were mapped with the following attitudes:  
 Discontinuity set 1 – N 70° E, 30° NW  
 Discontinuity set 2 – N 10° E, 20° NW
- For the purposes of initial access to the working level, a slope trending N 40° E, 40° NW is to be cut. Using stereographic projection, determine:
- i) The **direction** and **plunge** of the line of intersection of the two discontinuities
  - ii) Whether or not the slope will be stable. Justify your answer.
- 4 (a) After construction of an underground parking space, it was discovered that ~~that~~ there was a discontinuity inclined at 30° underlying the parking platform. The total design vertical stress ( $\sigma_1$ ) on the platform was determined to be 680 kNm<sup>-2</sup>. If, as a result of this stress, a horizontal stress ( $\sigma_2$ ) of 310 kNm<sup>-2</sup> is induced on the discontinuity, determine the normal and shear stresses acting on the discontinuity as a result of the imposed stresses.
- (b) Shear box testing carried out on the discontinuity in 4 (a) gave the following results:

Normal stress, $\sigma_n$ (kNm <sup>-2</sup> )	50	100	200	300
Shear stress, $\sigma_\tau$ (kNm <sup>-2</sup> )	36	80	154	235

From the shear and normal stresses determined in 4 (a), would failure occur on the discontinuity plane? Explain your answer.

- 5 (a) (i) What role has refraction seismics in engineering geology?  
(ii) What is the aim of a site investigation?  
(iii) Describe in some detail, the various stages of such an investigation
- (b) In one section of the site, a seismic refraction survey was done to determine the average depth to rock head and gave the following results:

Geophone distance (m)	10	15	20	25	30	35	40	45	50	55
Arrival times (ms)	3	4.5	6	7	7.8	8.5	9	10	10.6	11.5

Assuming that the layers are horizontal, calculate:

- i) The wave velocities in each layer  
ii) The depth to rock-head.

- 6 a) Discuss the geologic / geotechnical data required in the design of a surface excavation.
- b) There is a plan to construct a new stadium at the Goma Fields. The stadium will involve excavating the ground to some depth. A shear zone is envisaged to 'daylight' into the excavation. The data for the slope and shear zone are given in ~~the~~ Figure 1. Write a short report stating, whether or not this scenario poses any cause for concern with regard to the stability of the slopes. Determine the amount of force in a rock-bolt installed horizontally that would be needed to raise the factor of safety of the slope to 3.
- 7 Given below is a list of engineering and natural processes that affect the behaviour of the ground:
- (a) Static loading  
(b) Dynamic loading  
(c) Withdrawal of support by surface excavations  
(d) Withdrawal of support by underground excavations  
(e) Changes in fluid pressure

For the stability of Findeco House along Cairo Road, rank the processes in order of the most probable to the least probable causes of instability. Discuss your ranking.

\_\_\_\_\_END OF EXAMINATION. GOOD LUCK! \_\_\_\_\_

Figure 1 for Question 6 (b)

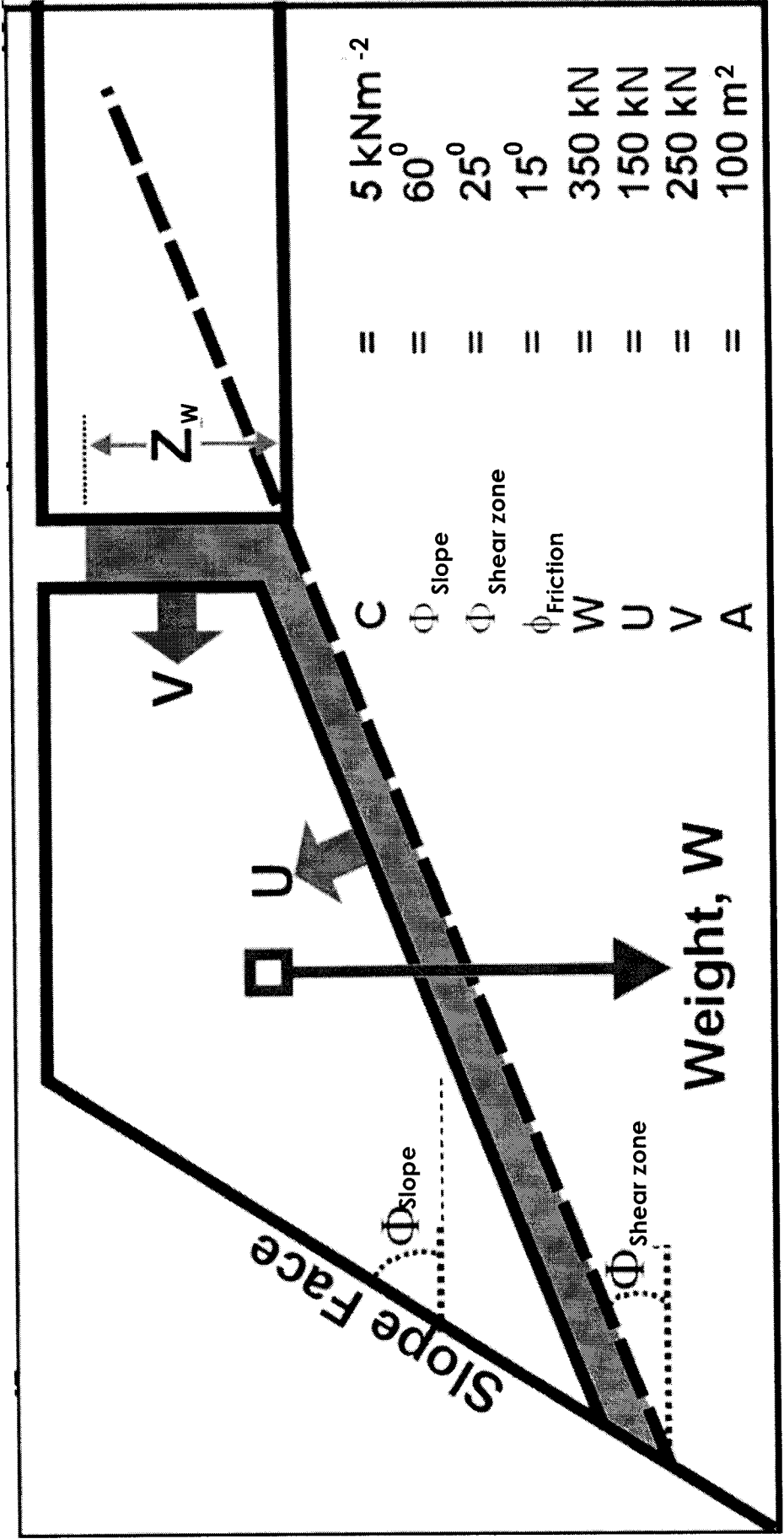

UNIVERSITY OF ZAMBIA

UNIVERSITY EXAMINATIONS – FIRST SEMESTER, JUNE 2004

MG319 II : COMPUTER TECHNIQUES

PRACTICAL

TIME: 3 Hrs

INSTRUCTIONS: Answer ALL questions. Use formulas where applicable

**Question 1: Microsoft Word**

Open the Microsoft Word document **Company Profile**, saved on your Computer in the Directory **C:\mg319pexam**. Edit and format it to look like the hard copy of the Microsoft Document as in **Preview\_Qn1** on the **floppy Disk**. If you have any difficulties in saving on to the floppy, Save on hard disk in the same directory as above but, ensure that you state this on your answer sheet.

[ 50 Marks ]

Execute the following actions:

Create space on top of page and Insert any company logo picture from the **clipart** group of pictures provided in Microsoft Word.

The Document contains Main Heading , sub-headings and text body and some valuable points at the end:

Apply font style of **Courier New**, or **Bookman Old Style** or **IMPACT**; choose which ever will be available and **NOT** all.

Format Main Heading to Font Size of 18 of Bold type, Centered

Font size of 14 to sub-headings

Change the font size of the rest of the text body to 11

Change intermarket Company name to **IBM International**

Apply the bullet style of your choice to the Company focus mission statement.

Carry out spell-check to the document.

## Question 2: Microsoft Excel Spread Sheets

Create the following Microsoft Excel Spread Sheet document called **personal.xls** from your floppy.

[ 50 Marks ]

<b>A</b>	<b>B</b>	<b>C</b>	<b>D</b>	<b>E</b>
<b>GUYS AND DOLLS CLOTHING</b>				
<b>GARMENT</b>	<b>METRES PER GARMENT</b>	<b>PRICE PER METRE</b>	<b>TOTAL COST</b>	
JEANS	40000			
WAISTCOATS	20000			
JACKETS	100000			
DUNGAREES	80000			
CHITENGE	70000			
RIBONS	60000			

Enter the following Spreadsheet and carry out the following:

1. Centre the Title across the columns and Column Headings within the cells.
2. **EMBOLDEN** the title to give it emphasis
3. **INCREASE** the size of the Title to 20
4. **FORMAT** columns B, C and D Currency with 2 Decimal places
5. **INCLUDE** a formula to add Totals at the bottom of the list.
6. Emphasise on the Sale of **Jackets** and add a narrative about these same Jackets.
7. Do a pie chart on the Total cost of all Garments.

**THE UNIVERSITY OF ZAMBIA  
SCHOOL OF MINES**

**2004 ACADEMIC YEAR FIRST SEMESTER  
FINAL EXAMINATIONS**

**MI 209 INTRODUCTION TO MINE DEVELOPMENT**

**TIME: 3 HOURS**

**FULL MARKS: 100**

***INSTRUCTIONS: ANSWER 5 QUESTIONS***

---

1. You have been informed by villagers and their geologist in Solwezi that there exists a hill of rich copper sulphide mineralisation, which also extends 1 km from the surface. It is tabular but the area is hilly and forested.
  - a) Advise on the exploration methods your organisation would use and why. Explain the scientific bases of your advice and how they are used. **[4 marks]**
  - b) How would you go about estimating reserves and resources of this deposit? **[4 marks]**
  - c) What classes of reserves would you finally come up with before mining the deposit? **[4 marks]**
  - d)
    - i) What mining methods would you advise that can be used to exploit this deposit? It is stated that the enclosing rocks are strong and have a dip steep. **[4 marks]**
    - ii) Under what conditions do these methods most fit? **[4 marks]**
2. Two basic unit operations in mining are drilling and blasting with explosives.
  - a) Briefly outline the theoretical approaches to drilling mechanisms and consequent bit attack approaches. **[6 marks]**
  - b) Briefly explain the theory of detonation and important properties of explosives. **[6 marks]**
  - c) Classify major mining explosives. List the major differences between high explosives and low explosives. **[8 marks]**

3. Shaft sinking is a major development operation.
- e) *How would you go about sinking a shaft in a swamp with a bed rock 50m from the surface?* **[8 marks]**
  - f) What drilling methods and cut designs would you use? **[6 marks]**
  - g) What types of explosives would you use and why not ANFO? **[6 marks]**
4. As a government agency, your geological survey has found rich deposits in game park.
- a) What alternative exploitation strategies would you consider and state reasons for each strategy? **[8 marks]**
  - b) How would you protect the environment as a regulatory agency in this area? **[12 marks]**
- 5.
- a) On what process basis are major material handling machines classified? **[4 marks]**
  - b) Based on (a) above list, list six categories of material handling machines and mention at least two types of machines under each category. **[8 marks]**
  - c) Write short notes on 11 factors which one should consider when estimating hauling capacity? **[8 marks]**
6. i) Method of support and stope face orientation are factors used to classify mining methods.
- a) List the major mining methods. **[6 marks]**
  - b) Write short notes on major stope support methods. **[8 marks]**
- ii) Elaborate on the two principles on which bolt support systems are based. **[6 marks]**

**END OF EXAMINATION**

**UNIVERSITY OF ZAMBIA**  
**SCHOOL OF MINES**  
**2004 FIRST SEMESTER FINAL EXAMINATIONS**  
**MI 431 – UNDERGROUND MINE DESIGN**

**TIME: THREE HOURS**

**FULL MARKS: 100**

**INSTRUCTIONS:** Answer any 5 questions

---

1. Mining methods can be classified based on rock response to mining which are explained by magnitudes of displacements in the country rock and constitutive behavior of host rock medium for mining. Using these two criteria, explain the difference between naturally supported and caving mining methods.

**[20 Marks]**
2. Explain briefly:
  - i) Factors influencing ore-flow/draw in sublevel caving under waste rocks;

**[ 10 Marks]**
  - ii) Janelid and Kvapil ellipsoid concept about gravity flow of ore.

**[ 10 Marks]**
3. Vertical crater retreat (VCR) Method is sometimes referred to as a modernized version of sublevel stopping. However, this method is characterized by certain distinguished features which make it a unique method.
  - a) Why is this method referred to as a modernized version of sublevel stopping?

**[5 Marks]**
  - b) Describe in detail the main characteristic features of VCR method.

**[15 Marks]**
  - c) Evaluate K.C. Livingstone's theory on critical depth of placement of spherical charges and use this to get his formula for calculating blasting parameters of the charge.

**[10 Marks]**

3. Classify and describe in detail ore-losses and state their negative effects on the operations of the mine. **[20 Marks]**
4. Describe briefly :
- i) Five major Factors affecting the choice of level interval; **[ 10 Marks]**
  - ii) How optimum level interval is calculated based on mining cost and show this on the graph. **[10 Marks]**
5. Breaking of ore in the stop is usually carried out by using short and long blast holes.
- i) With the help of clear diagrams suggest possible ways of locating blast holes in rock medium during stopping process; **[10 Marks]**
  - ii) What are the advantages and disadvantages of using parallel and fan holes. **[10 Marks]**
6. Block caving is a massive underground mining. Describe this mining method under the following headings:
- i) Main characteristic features **[ 5 Marks]**
  - ii) Suitable ore-body and country rock **[5 Marks]**
  - iii) Stope development **[5 Marks]**
  - iv) Stopping sequence **[5 Marks]**

**END OF EXAMINATION**

**THE UNIVERSITY OF ZAMBIA  
SCHOOL OF MINES  
2004 ACADEMIC YEAR FIRST SEMESTER  
FINAL EXAMINATIONS**

**MI 435: SURFACE MINE DESIGN**

**TIME: THREE HOURS**

**FULL MARKS: 100**

**INSTRUCTIONS: ANSWER ALL QUESTIONS IN SECTION A AND ANY TWO QUESTIONS IN SECTION B. Ensure that the filled out answer sheet for Question 1 is handed in at the end of the examination. You may use a non-programmable calculator and a transparent 45<sup>0</sup> or 60<sup>0</sup> set-square.**

---

**SECTION A**

1. (a) On the attached Fig 1 of Grasberg Pit in Indonesia, identify and label the nine arrowed geometrical features, and comment on what operation you think is in progress. **[10 marks]**
- (b) On the attached Fig 2:
- (i) Identify and label the arrowed equipment shown, and name three types of such equipment commonly used in open pits (separately); **[2.5 marks]**
- (ii) Identify and label the arrowed equipment, and explain its working mechanism; **[2.5 marks]**
- (iii) Identify and label the arrowed equipment, and explain the functional difference between it and a grader; and **[2.5 marks]**

- (iv) Identify and label the arrowed equipment, and explain the difference between it and a mast drill. **[2.5 marks]**
2. Name and discuss in detail the surface mining methods and equipment employed or projected to be used at the following mine sites on the Copperbelt of Zambia:
- (a) Nchanga Mine of Konkola Copper Mines plc at Chingola; **[10 marks]**
- (b) Ndola Lime Company at Ndola; and **[5 marks]**
- (c) Mufulira Mine of Mopani Copper Mines plc. **[5 marks]**
3. Determine and show, from the orebody net revenue per block data in the attached Table 1, the ultimate pit limit for the most profitable pit using the two dimensional Lerchs Grossman algorithm. Assume slope is 1:1 and that positive values coincide with ore. Show all intermediate tables in your computation. **(20 marks)**
4. (a) Identify and tabulate the major surface mining methods, as well as the orebody characteristics favourable for their selection. **[7 marks]**
- (b) Tabulate the main advantages and disadvantages of the major surface mining methods. **[6.66 marks]**

## SECTION B

5. (a) Define the term 'geotechnical template' as used in open pit mining, and illustrate the methodology employed in constructing geotechnical templates based on slope failure probabilistic risk. **(3 marks)**
- (b) A cobalt mine with a small deposit had a life of six years in which it stripped waste and mined payable ore from two cuts as tabulated in the attached Table 2:
- (i) What were the overall volumetric and tonnage stripping ratios for Cut 1, assuming the specific gravity for waste was 2.5 and that for payable ore was 2.25? **[5.66 marks]**
- (ii) What was the volumetric instantaneous stripping ratio for Cut 2 at the end of Year 3? **[2.5 marks]**
- (iii) What was the volumetric annual periodic stripping ratio for the mine for Year 4? **[2.5 marks]**
6. (a) Two young undergraduates were overhead arguing about the terms 'grade factor' and 'mining dilution', one argued that they were 'the same thing really' while the other insisted they were 'opposite'. Clarify the issues for the two undergraduates, including formulae. **[2 marks]**

(b) Illustrate the linkage of surface mining unit and functional processes, and show how their structural linkage can be employed to capture and profile mining costs. [2 marks]

(c) 9 000 tonnes of ore was actually received at mill from a bench, whose in situ bench grade was 3 %. The grade factor was 50 %, and the tonnage factor was 90 %. What was the mining recovery? [7.66 marks]

(d) Discuss four key concerns in an open pit drainage and dewatering system that have to be addressed, for safe and efficient management of water. [2 marks]

7. (a) Describe the use of the recently installed 'Ground Probe Radar' at Nchanga Open Pit, Chingola, and comment on the role it plays in steepening slopes and reducing stripping ratios. [6.66 marks]

(b) Explain the use of stripping curves in manual open pit design for the determination of ultimate pit limits. [7 marks]

**PLEASE TURN OVER**

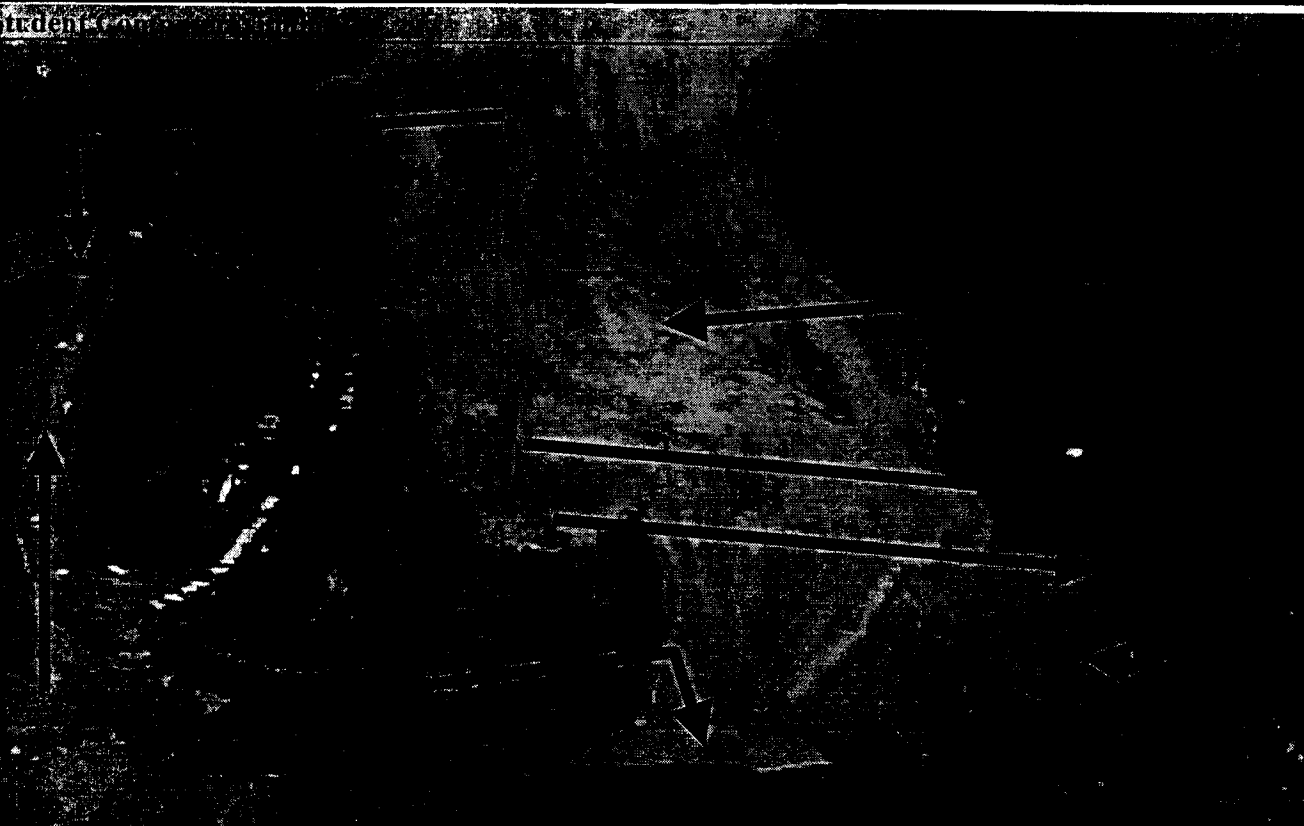

**Grasberg Pit Indonesia Collapse October 200**  
 Figure 1 for Question 1 (a) - Label the 9 arrows

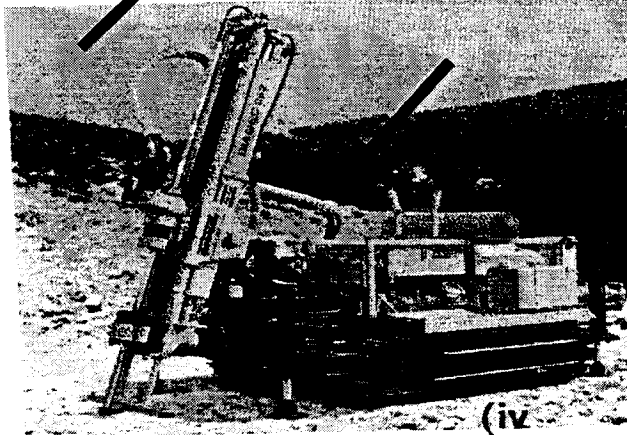
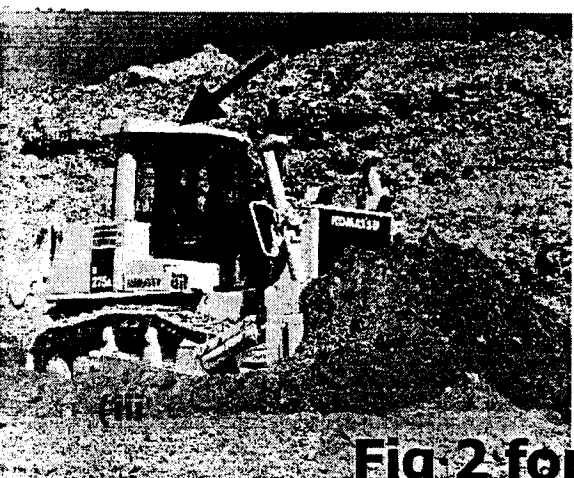
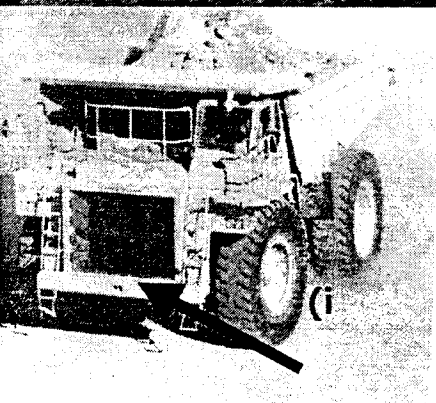

**Fig 2 for Question 1 (b)**

World Mining Equipment

Please turn over

**Table 1 for Question 3**

**Net Revenue Values per Block (also called net block values) Any Monetary Unit**

-10.00	-10.00	-10.00	10.00	50.00	-10.00	-10.00	-10.00	-10.00	-10.00	-10.00	-10.00
-10.00	-10.00	-10.00	10.00	-10.00	95.00	50.00	-10.00	-10.00	-10.00	-10.00	-10.00
-10.00	-10.00	-10.00	90.00	10.00	200.00	-10.00	-10.00	-10.00	-10.00	-10.00	-10.00
-10.00	-10.00	-10.00	100.00	-10.00	100.00	90.00	-10.00	-10.00	-10.00	-10.00	-10.00
-10.00	-10.00	-10.00	-10.00	-10.00	25.00	-10.00	-10.00	-10.00	-10.00	-10.00	-10.00
-10.00	-10.00	-10.00	-10.00	-10.00	-10.00	-10.00	-10.00	-10.00	-10.00	-10.00	-10.00
-10.00	-10.00	-10.00	-10.00	-10.00	-10.00	-10.00	-10.00	-10.00	-10.00	-10.00	-10.00

**Table 2 for question 5: Waste and Cobalt ore mining schedule**

	Year 1	Year 2	Year 3	Year 4	Year 5	Year 6
Cut 1						
Waste, bcm	0	4,500,000	4,500,000	5,000,000	8,000,000	0
Payable Ore, t	0	1,000,000	1,500,000	1,250,000	2,000,000	0
Cut 2						
Waste, bcm	0	10,000,000	7,500,000	4,500,000	0	0
Payable Ore, t	0	2,000,000	2,500,000	1,500,000	0	0

**END OF EXAMINATION, GOOD LUCK!**

**THE UNIVERSITY OF ZAMBIA  
SCHOOL OF MINES**

**2004 ACADEMIC YEAR, FIRST SEMESTER**

**FINAL EXAMINATIONS**

**MI 455: OPERATIONS RESEARCH**

**TIME: THREE (03) HOURS**

**FULL MARKS 100**

**INSTRUCTIONS: ANSWER QUESTION 1 AND ANY FOUR (04)**

---

**QUESTION 1 - COMPULSORY**

A local coal mining company operating an underground mine has eight production faces in operation. Data with respect to these faces are given in the table below;

Table: Data with respect to the faces

<b>Face</b>	<b>Coal Type</b>	<b>Maximum Production [t/d]</b>	<b>Sulphur Content [%]</b>	<b>Ash Content [%]</b>	<b>Fines [%]</b>	<b>Contribution [\$t]</b>
1	Power	1000	1.2	10	10	30
2	Power	1500	1.7	12	10	25
3	Power	1000	1.1	8	15	20
4	Coking	2000	1.8	6	15	10
5	Power	1500	1.5	2	10	25
6	Coking	1000	1.2	6	10	10
7	Coking	2000	1.3	10	20	10
8	Coking	1000	1.1	10	20	15

## Notes

- ◆ Faces 1, 2 and 3 supply coal to a common loading point which has a capacity of 3250 t/d (Three thousand two hundred and fifty).
  - ◆ The main hoisting shaft has a capacity of 10000 t/d (Ten thousand)
  - ◆ Maximum sulphur content in the ROM coking coal should be 1.4%.
  - ◆ Maximum ash content in the ROM coking coal should be 7.8%.
  - ◆ Maximum fines in the power coal should be 500 t/d (Five hundred).
- (a) Describe the steps one should follow in formulating a linear programming model. **[5 marks]**
- (b) Formulate an Optimization Model for a production plan to maximize the total daily contribution. Use  $X_1, X_2, \dots, X_8$  to represent the proposed coal tonnages to be produced from each of the eight production faces. **[15 marks]**

## QUESTION 2

The following are details for the times required for the maintenance of a mining shovel.

Activity	Description	Times [hours]		
		Most Optimistic	Most Likely	Most Pessimistic
A	Move shovel from face	4	6	8
B	Service electrical parts	8	12	16
C	Service mechanical parts	6	10	12
D	Perform test run	6	10	12
E	Prepare new face	3	5	6
F	Move shovel to new face	2	4	8

Assume that the maintenance of the mechanical and electrical parts can be performed simultaneously. Also assume that the preparation of the new face can only start when the servicing of the electrical parts has been completed, since the maintenance and installation of the power supply at the face is done by the same team of electricians.

- [a] Draw a PERT network for the maintenance work [4 marks]
- [b] Find the critical path. [3 marks]
- [c] What is the probability of completing the project within 35 hours? [8 marks]
- [d] If you had to estimate a time for project completion, and wanted to be 95% confident of completion by this time, what would be your estimate? [5 marks]

### QUESTION 3

The following is a Simplex tableau for a linear programming model.

$C_j$			6	20	12	0	0
	<b>Basic Variables</b>	<b>Quantity</b>	$X_1$	$X_2$	$X_3$	$S_1$	$S_2$
6	$X_1$	20	1	1	0	0	0
12	$X_3$	10	0	1/3	1	0	-1/6
0	$S_1$	10	0	1/3	0	1	-1/6
	$Z_j$	240	6	10	12	0	-2
	$Z_j - C_j$		0	-10	0	0	-2

- [a] Is this a maximisation or a minimisation problem? Why? [4 marks]
- [b] What is the solution given in this tableau? [2 marks]
- [c] Is the solution given in this tableau optimal? Why? [2 marks]
- [d] Write down the original objective function for the linear programming model using **only** decision variables. [2 marks]
- [e] How many constraints are in the linear programming model? [2 marks]
- [f] Were any of the constraints originally equations? Why? [4 marks]
- [g] What is the value of  $X_2$  in this tableau? [2 marks]
- [h] In the tableau above,  $S_1 = 10$ . What does this mean? [2 marks]

## QUESTION 4

(a) Discuss the following

- (i) Balanced and unbalanced transportation model **[3 marks]**
- (ii) Degeneracy in a transportation problem and how it is remedied **[3 marks]**
- (iii) How are multiple optimal solutions identified in a transportation problem?  
**[4 marks]**
- (iv) Penalty cost **[2 marks]**

(b) In an underground mine operations at Konkola Copper Mines Plc, four Jackhammers are to be used to drill four ends. The table below shows the four ends the must be driven and the Jackhammers that must be assigned to these ends. The matrix entries represent costs in dollars.

Table: Showing ends to be driven and the jackhammers to be assigned to these ends.

<b>Jackhammers</b> <b>Ends</b>	<b>1</b>	<b>2</b>	<b>3</b>	<b>4</b>
2310 Tip Cross-cut	6	5	7	4
2350 Drilling drive	5	8	3	8
2350 Vent Raise	6	3	4	7
2350 Haulage	10	8	7	4

If you are a Mine Captain of this area, what assignment would you adopt in order to ensure that all four ends are completed at minimum cost? What is the total cost of the assignment? **[8 marks]**

### QUESTION 5

An underground pump station has currently a single pump machine on which underground loaders come to refuel. Over the course of a working day, the loaders come to refuel at random times and arrive at the rate of one every ten minutes. The rate at which the pump can be used is randomly distributed but does approximate a Poisson distribution with a mean rate of eight per hour. A loader driver is paid at the rate of \$5 per hour. Determines;

- (i) The percentage of time that the pump is idle; **[4 marks]**
- (ii) The average length of the queue; **[4 marks]**
- (iii) The average time which a loader spends in the queue after arriving for service. **[4 marks]**
- (iv) The average time which a loader spends in the system after arriving for service; **[4 marks]**
- (v) The average cost per job as a result of the loader waiting in the queue. **[4 marks]**

### QUESTION 6

- (a) Discuss the simplifying assumptions of the Economic Order Quantity (EOQ) Model? **[4 marks]**
- (b) An Inventory system has an annual ordering cost of \$200 per order, an annual per unit carrying cost of \$0.75, and an annual demand of 5000 units (assuming a 365-day year), compute the following:
  - (i) Economic Order Quantity (EOQ) **[4 marks]**
  - (ii) Minimum total annual inventory cost **[4 marks]**
  - (iii) Optimal number of orders per year **[4 marks]**
  - (iv) Optimal time between orders **[4 marks]**

**QUESTION 7**

(a) How does the a stage differ from a state in a dynamic programming problem?  
**[5 marks]**

(a) Kansanshi Mines in North Western Province is just starting up its mining operations and has budgeted US\$4 million for capital improvements for the next financial year, to be allocated (in US\$1 million blocks) among three shafts i.e. Shaft A, Shaft B and Shaft C. Each shaft needs at least US\$1 million to undertake a project. The company has limited investments to US\$3 million per shaft. The expected return accruing from each investment is estimated as follows.

Allocation (US\$ millions)	Expected Return (US\$ Million)		
	Shaft A	Shaft B	Shaft C
1	2	4	3
2	5	8	10
3	6	7	9

If the company decides not to invest at a shaft, the return is zero. The company wants to invest the entire US\$4 million. Determine the investment decision at each shaft using Dynamic Programming.  
**[15 marks]**

**END OF EXAMINATION**

**THE UNIVERSITY OF ZAMBIA  
SCHOOL OF MINES  
2004 ACADEMIC YEAR FIRST SEMESTER  
FINAL EXAMINATIONS**

**MI 555: MINING GEOSTATISTICS**

**TIME: THREE HOURS**

**FULL MARKS: 100**

**INSTRUCTIONS: ANSWER ALL QUESTIONS IN SECTION A AND ANY FOUR QUESTIONS IN SECTION B. READ QUESTIONS CAREFULLY. You may use a non-programmable calculator.**

---

**SECTION A**

1. Use Fig 1 to:

- (a) Construct an appropriate Kriging coefficient matrix for determination of the unknown iron ore grade at point p from known value points 1, 2 and 3; **[2 marks]**
  
- (b) Solve for the Kriging coefficients and the La Grange multiplier for the determination of the unknown iron ore grade at point p; **[12 marks]**
  
- (c) Krig estimate the iron ore grade at point p if the grades at points 1, 2 and 3 are 10, 20 and 25, respectively; **[2 marks]**
  
- (d) Estimate the Kriging error associated with the Kriged iron ore grade at point p; and **[2 marks]**

(e) Compute the 95% confidence limits for the Kriged grade at point p.

**[2 marks]**

2. The Geo-statistician discovered that the nugget intercept value had not been plotted correctly on Fig 1, but should have been zero, with everything else staying the same. In the light of this, use Fig 1 to:

(a) Construct an appropriate Kriging coefficient matrix for determination of the unknown iron ore grade at point p from known value points 1, 2 and 3; **[2 marks]**

(b) Solve for the Kriging coefficients and the Lagrange multiplier for the determination of the unknown iron ore grade at point p; **[12 marks]**

(c) Krig estimate the iron ore grade at point p if the grades at points 1, 2 and 3 are 15, 20 and 17.5, respectively; **[2 marks]**

(d) Estimate the Kriging error associated with the Kriged grade at point p; and **[2 marks]**

(e) Compute the 95% confidence limits for the Kriged grade at point p. **[2 marks]**

## **SECTION B**

3. (a) Differentiate between ‘first order’ and ‘second order’ stationarity conditions as they apply to geostatistical semi variograms; **[2 marks]**
- (b) Describe the structure of three types of semi-variograms under second order stationarity conditions, including formulae for associated relationships; **[6 marks]**
- (c) Illustrate three types of unsilled semivariograms, including associated relationships; and **[5 marks]**
- (d) Illustrate ‘hole-effect’ semi variogram models with and without sills. **[2 marks]**
4. (a) Define the term ‘regionalised variable’ and describe the three main components of such a variable; **[5 marks]**
- (b) Define the following geostatistical terms:
- (i) ‘Deconvolution’ and ‘Data transform’; **[1 mark]**
  - (ii) ‘Pseudo-periodicity’; **[1 mark]**
  - (iii) ‘Parallelopiped’ and ‘Nested structures’; **[1 mark]**
  - (iv) ‘Pure nugget effect’; **[1 mark]**
  - (v) ‘Level or scale of observation’ and ‘Declustering’; **[1 mark]**
  - (vi) ‘Spatial independence’ and ‘Additivity of variances’; **[1 mark]**

- (vii) 'Permanency' and 'Geostatistics'; **[1 mark]**
  - (viii) 'Estimation variance' and 'Intrinsic hypothesis'; **[1 mark]**
  - (ix) 'Co-regionalisation' and 'cross-variogram'; and **[1 mark]**
  - (x) 'Support' and 'regularisation'. **[1 mark]**
5. (a) Define the terms 'ore blending' and 'grade control', and explain the compilation process of monthly and annual mine ore grade and tonnage sampling and reconciliation of 'Delivered to Mill' (DTM) and 'Received at Mill' (RAM) statistics. **[7 marks]**
- (b) Tabulate two empirical systems of key criteria for the selection of ore resource computational methodologies based on coefficient of variation of grade distributions of mineral deposits. **[8 marks]**
6. (a) Discuss two Kriging methods used for the estimation of global mineral resources for a large deposit, including an explanation of why one is preferred over the other for mineral resource estimations. **[5 marks]**
- (b) Identify and fully illustrate four sampling systems used in physically locating lineal samples. **[5 marks]**
- (c) Define the terms 'grab sampling' and 'channel sampling', with their advantages and disadvantages, and detail how they are physically conducted underground. **[5 marks]**

7. (a) The term 'BLUE' is associated with Kriging, explain the meaning of the term, and what are the critical advantages and disadvantages of Kriging over other data interpolation and extrapolation mechanisms. **[5 marks]**
- (b) Define the term 'structural analysis' as used in geostatistical analysis of a mineral deposit, and illustrate, in detail, key features of such analysis. **[10 marks]**

**Please turnover**

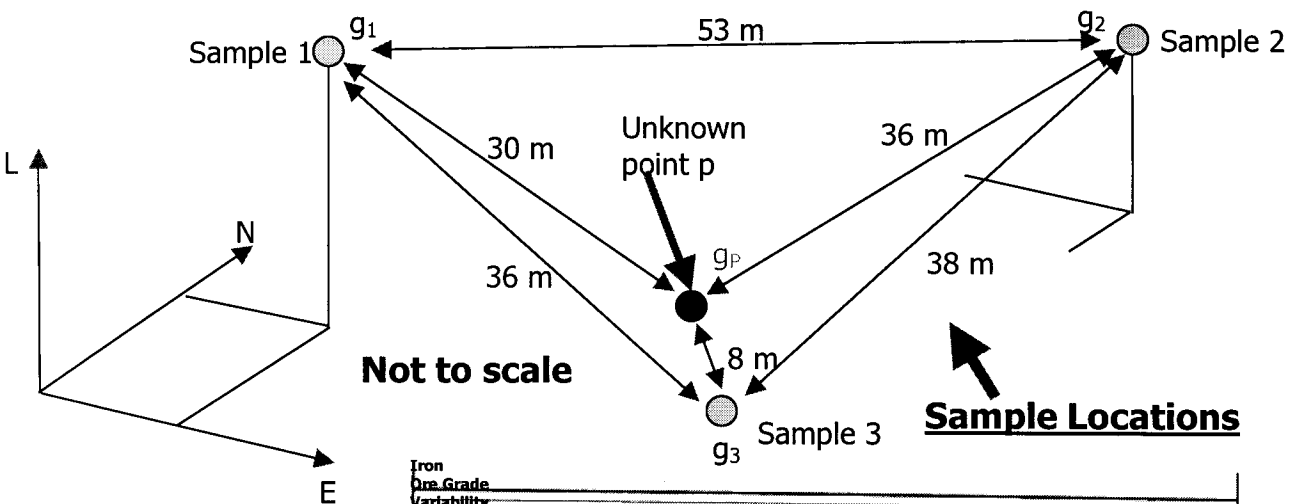

Use the semi variogram model of a hypothetical iron ore deposit with point to point sample distances and iron ore grade sample values to predict iron ore grades at a point located between the samples. (Drawing modified from Houlding, Geoscience Modelling)

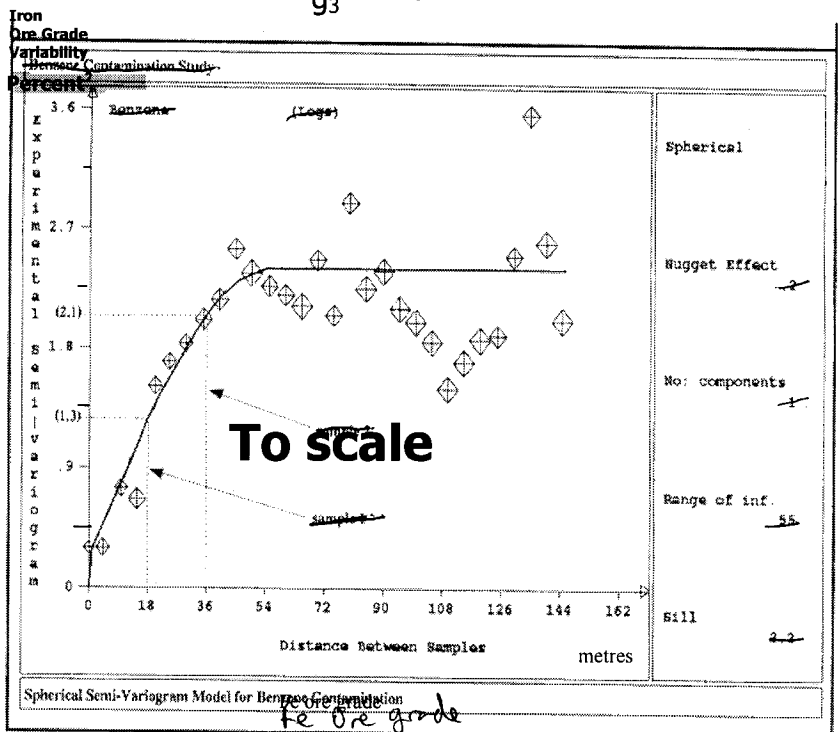

**Spherical semi-variogram model for Iron ore grades**

Fig 1 for both Questions 1 and 2

**END OF EXAMINATION, GOOD LUCK!**

**THE UNIVERSITY OF ZAMBIA**  
**SCHOOL OF MINES**  
**2004 ACADEMIC YEAR FIRST SEMESTER**  
**FINAL EXAMINATIONS**

**MI 585: MATERIALS HANDLING**

**TIME: THREE (03) HOURS**

**MARKS 100**

**INSTRUCTIONS: ANSWER QUESTION 1 AND 2 AND ANY OTHER THREE QUESTIONS**

---

**QUESTION 1**

Write notes on and explain the Fundamentals of Equipment Selection under the following sub-headlines:

- a) The eight (08) major factors that must be considered when selecting equipment for Materials Handling in mining; **[10 marks]**
- b) Supplementary five (05) factors that require consideration in the choice of equipment and machinery for Materials Handling; **[3 marks]**
- c) The role, importance and impacts of Circular Analysis during mine optimisation in relation to equipment selection. **[7 marks]**

**QUESTION 2**

State, and with the aid of corresponding machine types, describe the four (04) major areas of machine application and working environment in mining indicating specific and typical examples of machines deployable on each of the unit operations of Materials Handling. **[20 marks]**

**QUESTION 3**

There exists three basic methods of estimating the capacity of excavating equipment i.e. Design, Technical and Effective Capacity.

You are required to define, explain and state the applicability and limitations of each of the three capacity estimate types. **[20 marks]**

## QUESTION 4

- a) Write short notes on ripping as a materials handling method in surface mining laying special emphasis on:
- i Machine specifications like Machine weight and horse-power rating; **[4 marks]**
  - ii Ripper types and design parameters of the working tool of the ripper; **[4 marks]**
  - iii The two method of estimating production in ripping. **[4 marks]**
- b) Given the following data and information, you are required to determine the hourly production on ripping and the cost of ripping per BCM:
- Machine Type .....CAT D10-N with a D10-N Ripper
  - Average speed (inclusive of slippage and stalls)...1.85 km/hr
  - Rip spacing.....975 mm
  - Ripper penetration.....1 350 mm
  - Rip distance..... 225 m
  - Manoeuvre time.....0.5 min **[8 marks]**

### ASSUMPTIONS:

- i. 55-minute working-hour
- ii. O&O costs (inclusive of \$35/hr for operator) = \$ 350.00/Hr

## QUESTION 5

- a) Write notes on the application of Load Haul and Dump (LHD) units as materials handling machines in underground mining. **[4 marks]**
- b) The following data and information on the materials and the machines for possible deployment is available:
- Material Type:.....Overburden Mudstone
  - Specific Gravity (Loose).....2.00 Tonnes/LCM
  - Specific Gravity (Bank).....2.85 Tonnes/BCM
  - Target Annual Production.....7 500 000 BCM
  - Loader Type.....Marathon M-1100
  - Bucket Size.....16 cubic meters
  - Average Cycle Time.....30 seconds
  - Bucket Fill Factor.....95%
  - Minutes per Hour.....55
  - Availability.....90%
  - Utilization.....90%
  - Deployment...3x8-hour shifts per day and 260 days per annum
  - Truck Haulage

Truck Alternatives	Cat 777	Cat 785	Cat 789
Body Capacity	.51 cu.m	78 cu.m	105 cu.m
Payload	86 T	136 T	177 T
Spot Time at Loader (s)	20	20	20
Waiting Time at Loader (s)	10	10	10
Travel Distance (one-way)	3 500	3500	3500
Travel Speed Loaded	30km/hr	30km/hr	30km/hr
Travel Speed Empty	60km/hr	60km/hr	60km/hr
Spot and Dump Time (s)	25	25	25
Minutes per Hour	55		
Availability	95%		
Utilization	95%		

You are required to:

- i) Determine the loader hourly performance, and the number of loaders to fulfill the annual production requirement of 7 500 000 BCM **[4 marks]**
- ii) Determine the hourly performance and number of truck loads per hour for each of the three alternative truck sizes **[4 marks]**
- iii) Match and select the most suitable truck size to be deployed to the loader **[4 marks]**
- iv) Determine the total fleet size for loading and haulage machines for the target annual production **[4 marks]**

## QUESTION 6

Write short notes and with the aid of sketches where applicable describe:

- a) The composition, classification and types of hoisting systems **[6 marks]**
- b) Shaft types and tasks **[4 marks]**
- c) Construction types of winding towers **[3 marks]**
- d) Construction and operation of a Friction (Koepe) Hoist **[7 marks]**

## QUESTION 7

- a) State and with the aid of corresponding sketches, briefly explain the principles of bit penetration in percussive drilling paying special attention to chip/crater formation, role and influence of flushing medium and chip bailing/penetration rate. **[4 marks]**
- b) Write brief notes on the application and limitations of the following drilling methods as applied in mining:
  - Percussive Blasthole Drills **[4 marks]**

- Rotary Blasthole Drills [4 marks]
- Roto-Percussive Blasthole-Drills [4 marks]
- DTH-Drills [4 marks]

**END OF EXAMINATION AND GOOD LUCK!**

THE UNIVERSITY OF ZAMBIA

UNIVERSITY EXAMINATIONS – JUNE/JULY 2004

MM321  
PHYSICAL METALLURGY I

TIME: THREE HOURS

ANSWER: ALL THE QUESTIONS

---

What materials would you select for the following applications and why?

- a) Solder for electronic equipment
- b) Photographic equipment
- c) Fuse wire
- d) Filament of an incandescent light bulb
- e) Crank shaft

a) The general equation for the free energy change associated with nucleation is

$$\Delta G = v\Delta G_v' + A\gamma + v\Delta G_e$$

For a spherical nucleus, derive the expressions for the critical nucleus size and the energy barrier to nucleation under homogeneous nucleation conditions.

b) Why is homogeneous nucleation such a rare phenomenon?

c) How are the limitations to homogeneous nucleation overcome?

d) For a stable nucleus located at a grain boundary, illustrate with a sketch the mechanisms by which it acquires solute during growth.

a) What was the main reason that led to the proposal of dislocation theory?

b) Using the vectors  $\mathbf{b}$  and  $\boldsymbol{\xi}$ , distinguish between an edge and a screw dislocation.

c) Why is a jog on a stepped screw dislocation unable to move by glide?

d) The total line length of the dislocations visible in a 4 cm by 4 cm transmission electron microscope (TEM) photograph of a metal foil, taken at a magnification of 20,000X is measured as 400 cm. The foil specimen imaged by this picture had a thickness of 300 nm. Determine the dislocation density in the specimen.

a) Why is it important for structures to be operated at stress levels below their yield strength?

b) For a material that does not exhibit a pronounced yield point on its stress-strain curve, how would you determine its yield strength from such a curve?

- (c) During a tensile test on cold-worked brass, the following data was obtained for load and corresponding extension:

<u>Extension (mm)</u>	<u>Load (kN)</u>
0.1	23
0.2	46
0.3	69
0.4	82
0.5	89
0.6	94
0.8	102
1.0	110
1.5	123
2.0	131
2.5	136
3.0	139
4.0	132
4.3	118 Fracture

The diameter of the test piece was 16 mm and the gauge length used was 80 mm. Draw the load-extension curve and determine:

- Young's modulus of elasticity
- 0.2% yield strength
- Tensile strength
- Percentage elongation of the material

- (a) Distinguish between interstitial, and substitutional diffusion.

- (b) Fick's second law for the diffusion of species A can be expressed as

$$\frac{\partial C_A}{\partial t} = D_A \frac{\partial^2 C_A}{\partial x^2}$$

- Why is the change in concentration of species A with time,  $\delta C_A / \delta t$ , expressed as a partial derivative?
- Describe how you would use the solution to this equation to predict the time required for species A to penetrate into a material.

- (c) Metals A and B, whose atomic volumes are both  $10.3 \text{ cm}^3/\text{gm atom}$ , form ideal solutions ( $N=6.022 \times 10^{23} \text{ mol}^{-1}$ ).

- What is the concentration gradient  $\delta C_A / \delta x$  in a diffusion couple formed from these metals in a region where  $X_A$  changes from 0.30 to 0.65 within a distance of 0.1 mm?
- If the diffusion coefficient is  $10^{-10} \text{ cm}^2/\text{s}$  and the cross sectional area of the specimen is  $0.5 \text{ cm}^2$ , what is the flux of A atoms through a cross section within the region whose concentration gradient equals that found in part (i)?
- How many times per second would each atom jump? Assume a simple cubic crystal lattice and  $a = 3 \text{ \AA}$ ?
- What would be the mean time of stay of an atom at a simple cubic lattice site?

THE UNIVERSITY OF ZAMBIA

UNIVERSITY EXAMINATIONS – JUNE 2004

MM 331

CHEMICAL THERMODYNAMICS I

TIME: THREE HOURS

ANSWER: ANY FIVE QUESTIONS. ALL QUESTIONS CARRY EQUAL MARKS

---

1. One mole of an ideal gas is allowed to expand against a piston that supports 0.4 atm. pressure. The initial pressure is 10 atm. and the final pressure is 0.4 atm. The temperature is kept constant at 273 K.
  - (a) How much energy is transferred to the mechanical surroundings from the gas during the expansion?
  - (b) What is the change in internal energy and in the enthalpy of the gas?
  - (c) How much heat is absorbed from the thermal surroundings?
  
2.
  - (a) A chemical reaction in a gas mixture at 773 K decreases the number of moles of gas which can be assumed to behave ideally, by 0.347. If the internal energy change is -23, 800 J, what is the enthalpy change?
  - (b) What is the change in internal energy,  $U$ , and in enthalpy  $H$  suffered by 10 moles of  $\text{CO}_2$  if the temperature is raised from 373 K to 773 K, the pressure remaining constant at 0.1 atm? The heat capacity of  $\text{CO}_2$  is given by  $C_p = 44.2 + 8.79 \times 10^{-3} T - 8.62 \times 10^{-5} T^2 \text{ J}/(\text{mol})(\text{K})$
  
3. The initial state of one mole of an ideal gas is at  $P = 75 \text{ atm.}$  and  $T = 650 \text{ K.}$  Calculate the entropy change in the gas for;
  - (a) An isothermal decrease in the pressure to 25 atmospheres
  - (b) A reversible adiabatic decrease in the pressure to 25 atm.
  - (c) A constant volume decrease in the pressure to 25 atm.

4. Nitrogen gas is expanded reversibly and adiabatically from a volume of 1 litre at 273 K and 1 atm. until the volume is 2 litres. The heat capacities  $C_v$  and  $C_p$  can be taken to be constants at the values of 20.8 and 29.1 J/(mol)(K) respectively.

- (a) Assuming ideal gas behaviour, calculate the final temperature and pressure.  
 (b) Calculate  $q$ ,  $w$ ,  $\Delta U$ , and  $\Delta H$ .

5. For the oxidation reaction of a metal M  
 $M(s) + \frac{1}{2} O_2(g) \rightarrow MO(s)$  (i)

The accompanying standard enthalpy and entropy changes are  $\Delta H^\circ$  (i) and  $\Delta S^\circ$  (i).  $T_m$  is the melting temperature of the metal M at which the reaction below occurs;



whose enthalpy and entropy changes are  $\Delta H^\circ$  (ii) and  $\Delta S^\circ$  (ii).

- (a) Write the expression for the oxidation of the liquid metal.  
 (b) Sketch on the  $\Delta G^\circ$  versus T diagram the oxidation of the metal as it passes through a phase change. Explain why there is no discontinuity at  $T_m$ .

6. (a) In a copper converter, the following reaction is believed to occur in the latter stages

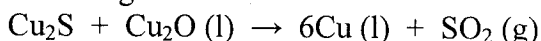

$$\Delta G^\circ = -364 - 21.46 T \text{ Joules}$$

Calculate the equilibrium partial pressure of  $SO_2$  at 1523 K. Assume that both  $Cu_2S$  and  $Cu_2O$  exist as pure melts.

- (b) Using the integrated form of the equation

$$\frac{d(\ln k)}{dT} = \frac{\Delta H}{RT^2}$$

Calculate the equilibrium constant at 800 K for the reaction

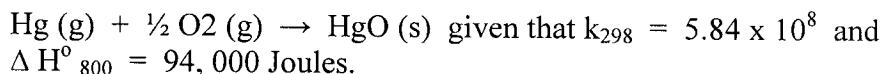

Relevant Information:

The gas constant  $R = 0.08206$  litre-atm/(mol)(K) or 8.314 J/(mol)(K)

1 litre-atm = 101.3 Joules

For ideal gases  $C_p = 2.5 R$  and  $C_v = 1.5 R$

**THE UNIVERSITY OF ZAMBIA**

**UNIVERSITY EXAMINATIONS – JUNE 2004**

**MM 411 - MINERAL PROCESSING I**

**TIME: 3 hours**

Answer questions 4 and any other four, but keep your answers brief and to the point.  
Relative weight of each question indicated in brackets.

**Question 1**

Consider a grinding circuit, consisting of a rod mill in open circuit and a ball mill in closed circuit with a hydrocyclone shown in Figure 1.

- (a) Imagine that, as part of a survey of the above circuit, samples were taken of the ball mill discharge and cyclone feed and of the cyclone underflow and overflow, and that sieve analyses of composite samples of these products gave the following results:

Fraction	Weight Percentages Retained			
	BMD	CF	CUF	COF
+ 212 $\mu$ m	24.4	27.1	34.9	3.6
+150 $\mu$ m	21.6	19.1	25.1	1.2
+106 $\mu$ m	25.0	20.2	22.5	13.3
+75 $\mu$ m	13.2	11.5	9.2	18.4
+53 $\mu$ m	10.4	9.7	3.9	26.9
-53 $\mu$ m	5.4	12.5	4.4	36.6

Calculate the circulating load over the ball mill / cyclone circuit as a percentage of new feed.

- (b) Calculate the recoveries to the cyclone underflow for the different size fractions and plot these against particle size on the graph paper.
- (c) What is the separating size in this cyclone operation, based upon these data?
- (d) What is the 'imperfection' in this cyclone operation, based upon these data?
- (e) If the discharge rate to the cyclone overflow is 95 tph (dry weight), what is the size distribution in the rod mill discharge?

**[20 %]**

**Question 2**

State briefly what you understand by the following terms, used in mineral processing:

- Percent suspension
- Bulk density
- Optimum mesh-of-grind
- Angle of nip
- Graded crushing
- Classification
- Porosity of a medium
- Separating size of a cyclone
- Specific surface (volume basis) of a group of particles
- Permeability of a medium

**[20%]**

**Question 3**

(a) Discuss the classification mechanism of a hydrocyclone with the aid of a clearly labelled diagram.

What are the main design variables and operating parameters of this cyclone?

(b) Hydrocyclones have replaced mechanical classifiers in most modern grinding plants. What are the advantages of hydrocyclones over mechanical classifiers?

(c) The most modern mechanical classifier is the rake classifier.

(i) Describe the operation of this classifier with the aid of a clearly labelled diagram, showing the various zones that can be distinguished.

(ii) What operation controls can be used on this type of classifier and state briefly how these controls influence the separation size in this classifier?

(iii) Describe what happens to the separating size when the feed to the classifier is diluted below and beyond the critical dilution.

[20%]

**Question 4**

The flowsheet shown in Figure 2 is that of a tin concentrator treating 30 dry tonnes per hour of ore.

The ore, containing 10 % moisture, is fed into a rod mill, which discharges a pulp containing 65 % solids by weight. The rod mill discharge is diluted to 30 % solids before being pumped to cyclones. The cyclone overflows, at 15 % solids, are pumped to the slimes treatment plant.

The cyclone underflow, at 40 % solids, and containing 0.9 % tin, are fed to a gravity concentration circuit, which produces a tin concentrate containing 45 % tin, and a tailing containing 0.2 % tin.

The tailing slurry, containing 30 % solids by weight, is dewatered to 65 % solids in a thickener, the overflow being routed to the mill header tank, which supplies water to the rod mill feed and rod mill discharge.

Calculate:

(i) The flowrate of make-up water required for the header tank.

(ii) The water addition needed to the rod mill feed.

(iii) The water addition needed to the rod mill discharge.

(iv) How much water is contained in the cyclone overflow per hour?

[20 %]

### **Question 5**

- (a) Describe the crushing action of a jaw crusher and a gyratory crusher with the aid of clearly labelled diagrams.

Describe the protection mechanisms of jaw crushers and gyratory crushers when an uncrushable material (e.g. tramp metal) enters the crushing cavity.

- (b) What are the essential differences between the grinding action of the rod mill and the ball mill? What is the effect of these differences in the grinding action on the size distribution in the respective mill products?
- (c) Describe the grinding action of a ball mill indicating the various zones that can be distinguished.
- (d) Give and discuss three factors that affect the grinding of ores.

[20 %]

### **Question 6**

- (a) What is understood by the 'fall diameter' of a particle and what is understood by its 'quartz diameter'?
- (b) What do you understand by the 'free settling ratio' of two minerals and what do you understand by their 'hindered settling ratio'?
- (c) Explain briefly, but clearly, why hindered settling ratios are larger than the corresponding free settling ratios.
- (d) The relationship of Richardson and Zaki is written as follows:

$$F_s = \frac{v_h}{v_t} = (1 - C_v)^n$$

- (i) What do the various symbols, used in this equation, represent?
- (ii) For what type of particles is this relationship valid?
- (e) When a mixture of fine quartz and baryte has been separated into fractions by beaker decantation, what would you observe if you studied the resulting size fractions under a microscope? S.G of quartz and baryte are 2.65 and 4.5 respectively.

[20%]

---

**END OF EXAMINATION IN MM 411**  
**GOOD LUCK!**

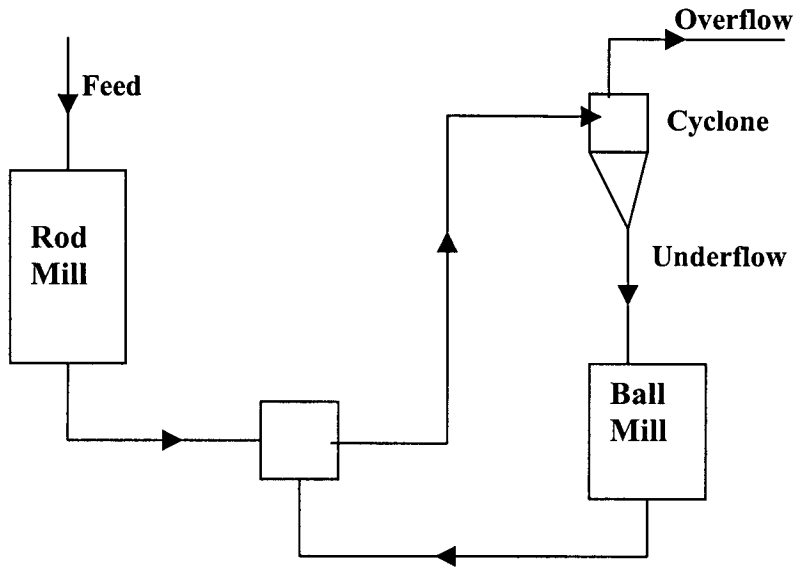

**Figure 1: Rod mill – Ball mill – Cyclone circuit**

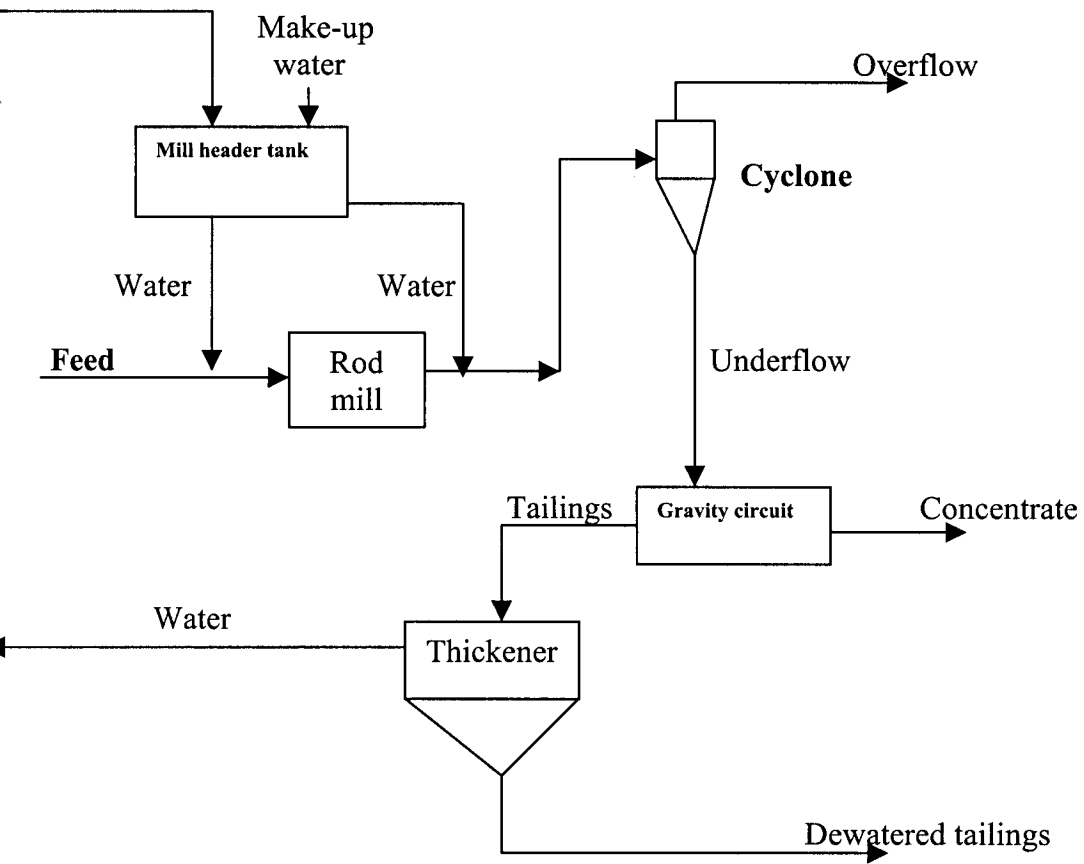

**Figure 2: Tin concentrator circuit**

THE UNIVERSITY OF ZAMBIA

UNIVERSITY EXAMINATIONS - JUNE, 2004

MM 441

PYROMETALLURGY

TIME: THREE HOURS

ANSWER: ALL QUESTIONS

THE CREDIT FOR A FULL ANSWER IS SHOWN IN BRACKETS BESIDE EACH QUESTION.

---

1(a) Given four unmarked samples of each of the agglomerates, sinter, pellets, briquets, and clinker, how would you identify each of the samples? (6%)

(b) A lead blast furnace produces 80 tonnes of lead per day which can be regarded as being 100% pure. In the same period, 15 tonnes of matte is also produced which has 9% Pb and 24% Cu. The slag leaving the furnace has 11% CaO. Assume that lead and copper do not enter the slag and that no solids are carried over into the gas.

The feed to the furnace comprises of a roasted lead concentrate, pyrite cinder, limestone, and coke. The coke is 90% carbon and 10% SiO<sub>2</sub> and the amount used is 18% of the roasted concentrate charged. The composition of the other feed materials is as follows:

Roasted concentrate: 47% PbO, 23% PbS, 30% SiO<sub>2</sub>.

Pyrite cinder: 86% Fe<sub>2</sub>O<sub>3</sub>, 6% Cu<sub>2</sub>S, 8% SiO<sub>2</sub>.

Limestone: 100% CaCO<sub>3</sub>.

Stating any assumptions you make about the matte and slag, calculate:

- (i) The weight of roasted concentrate smelted per day. (5%)  
(ii) The weight of pyrite cinder smelted per day. (7%)  
(iii) The composition of the slag produced. (7%)

Relative atomic weights: Pb = 207.2, Cu = 63.5, Fe = 55.8, S = 32.1, O = 16.0.

- 2(a) In a process to roast a pyrite concentrate to pyrite cinder, the calcine has some residual pyrite while the off-gas has 5% SO<sub>2</sub>.
- (i) How could the extent of pyrite roasting be increased? What would be the demerits of any measures you propose? (5%)
- (ii) How could the SO<sub>2</sub> content of the off-gas be improved? State the disadvantages of any measures you cite. (5%)
- (b) Use the data given below to construct two lines that would form part of the Co-S-O predominance area diagram at 700 °C. State any assumptions made in your calculations and label the drawn diagram. (10%)
- (c) A cobalt sulphide concentrate is roasted in a furnace in which the temperature has to be constant at 700 °C. The furnace atmosphere has an SO<sub>2</sub> partial pressure of 10<sup>0.5</sup> atm. and an O<sub>2</sub> partial pressure of 10<sup>-3.8</sup> atm. Using the partial predominance area diagram you have constructed, state assuming equilibrium is attained, what cobalt phase or phases would be present in the calcine. (5%)

Thermodynamic Data

$$R = 1.986 \text{ cal/deg/mol}$$

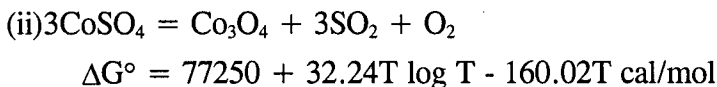
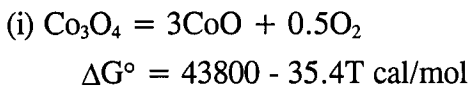

- 3(a) Name and give the chemical formulae of any four copper sulphide minerals and any three copper oxide minerals. (4%)
- (b) In the operation of a copper matte smelting reverberatory furnace, explain how the matte production rate can be maximized? (6%)

- (c) Two copper sulphide concentrates, named X and Y, destined for matte smelting in a reverberatory furnace are blended in a mass ratio of 2 parts X to 1 part of Y. If the concentrates analyze (gangue oxide composition only) as shown below, calculate how much limerock flux (with 54.0% CaO) needs to be added per tonne of the concentrate blend so that the normalized slag composition is: 59% SiO<sub>2</sub>, 31% CaO, and 10% Al<sub>2</sub>O<sub>3</sub>. State any assumptions made. (15%)

Concentrate	Gangue oxide composition			
	%Al <sub>2</sub> O <sub>3</sub>	%MgO	%SiO <sub>2</sub>	%CaO
X	4.43	1.96	17.5	1.05
Y	5.00	1.70	45.0	2.20

- 4(a) Concerning magnetite in copper converters, explain the following: (7%)
- its origin,
  - the problems its prevalence may cause to converter operations,
  - how its formation may be minimized.

- (b) During the copper blow of the Peirce-Smith converter, white metal at 1200 °C is blown to copper using air enriched with oxygen to 25% O<sub>2</sub>. The balance of the air can be taken as nitrogen. If the air blown into the converter enters at 25 °C, calculate the amount of copper scrap that has to be charged to the converter per tonne white metal in order for the converting temperature to remain constant at 1200 °C. Assume that the amount of air used is 30% in excess of stoichiometric requirements. Heat losses from the converter can be assumed to amount to 15.5% of the exothermic heat of reaction. (18%)

Thermochemical Data

Relative atomic weights: Cu = 63.5; S = 32.1

Heat capacities for copper:

$$\text{Cu}_{(s)}: C_p = 5.41 + 1.50 \times 10^{-3}T \quad \text{cal/deg/mol (range: 298 K - m.p.)}$$

$$\text{Cu}_{(l)}: C_p = 7.50 \text{ cal/deg/mol (range: m.p. - 1600 K)}$$

Latent heat of fusion of copper at 1083 °C,  $L_f = 3.12 \text{ kcal/mol}$ .

The enthalpy for the substances shown below is to be calculated using the formula:

$$H^\circ_T - H^\circ_{298} = aT + 0.5bT^2 + c/T + d \quad \text{cal/mol}$$

Substance	a	b x 10 <sup>3</sup>	c x 10 <sup>-5</sup>	d	H <sup>o</sup> <sub>298</sub>
Cu <sub>2</sub> S	24.10	-	-	-7152	-19000
O <sub>2</sub>	7.16	1.00	-0.40	-2044	-
N <sub>2</sub>	6.66	1.02	-	-2030	-
Cu	7.50	-	-	-2235	-
SO <sub>2</sub>	10.38	1.54	-1.42	-2729	-70940

---

END OF EXAMINATION

**UNIVERSITY OF ZAMBIA**

**SCHOOL OF MINES**

**UNIVERSITY EXAMINATION - JUNE 2004**

**MM 451**

**TRANSPORT PHENOMENA**

**TIME : THREE HOURS**

**ANSWER: FIVE QUESTIONS**

**ALL QUESTIONS CARRY EQUAL MARKS.**

**ADDITIONAL INFORMATION IS ATTACHED.**

---

- 1 (a) The mass,  $m$ , of drops formed by a liquid discharging by gravity from a vertical tube is a function of tube diameter,  $D$ , liquid density,  $\rho$ , surface tension,  $\sigma$ , and the acceleration due to gravity,  $g$ . Determine the independent dimensionless groups that would allow the surface tension effect to be analysed. Neglect any effects of viscosity. Use the following additional information:

<i>Variable</i>	<i>Dimension</i>
$m$	<b>M</b>
$D$	<b>L</b>
$\rho$	<b>ML<sup>-3</sup></b>
$\sigma$	<b>MT<sup>-2</sup></b>
$g$	<b>LT<sup>-2</sup></b>

- (b) The power,  $P$ , required to run a compressor varies with the compressor diameter,  $D$ , angular velocity,  $\omega$ , volumetric flow rate,  $Q$ , fluid density,  $\rho$ , and the fluid viscosity,  $\mu$ . Develop the pertinent dimensionless groups, where fluid viscosity and angular velocity each appear in only one dimensionless group. The dimensions of  $\omega$  and  $\mu$  are  $T^{-1}$  and  $ML^{-1}T^{-1}$ .

2. (a) The pressure distribution in a fluid is given as

$$P = xy + (x + z^2) + 10 \quad \text{kPa.}$$

What is  $\bar{\nabla} P$  at the point (10, 3, 4)? Find the component of  $\bar{\nabla} P$  in the direction  $\bar{e} = 0.4\bar{e}_x + 0.3\bar{e}_y$ .

- (b) A sea laboratory 5.0 m high is to be designed to withstand submersion to 100 m, measured from the sea level to the top of the sea laboratory. Calculate the gauge pressure in  $\text{kN/m}^2$  on top of the sea laboratory and also the variation of the gauge pressure on the side of the container measured as the distance  $y$  m from the top of the sea laboratory downward. The density of seawater is  $1020 \text{ kg/m}^3$ . Take  $g = 9.807 \text{ m/s}^2$ .

(c) An iceberg has a density of  $920 \text{ kg/m}^3$  in ocean water, which has a density of  $1020 \text{ kg/m}^3$ . If we observe a volume of  $2.8 \times 10^3 \text{ m}^3$  of the iceberg protruding above the free surface, what is the volume of the iceberg below the free surface of the ocean?

3. A storage vessel is well stirred and contains 500 kg of total solution with a concentration of 5 wt % salt. A constant flow rate of 900 kg/h of salt solution containing 16.67 wt % salt is suddenly introduced into the tank and a constant withdrawal rate of 600 kg/h is also started. These two flows remain constant thereafter. Derive the implicit equation relating the outlet withdrawal concentration as a function of time. *Also calculate the outlet concentration after 1.0 h and 2.0 h respectively.*

4. (a) A horizontal jet of water issues from a nozzle at a speed of 6 m/s and strikes a stationary flat plate oriented normal to the jet. The exit area of the nozzle is  $645 \text{ mm}^2$ . What is the total horizontal force (in Newtons) on the plate from the fluids in contact with it? Take the density of the water as  $10^3 \text{ kg/m}^3$ .

(b) A fluid of constant density is flowing in laminar flow at steady state in the horizontal x direction between two flat and parallel plates. The distance between the two plates in the vertical y direction is  $2y_0$ . Using the Navier-Stokes equations, taking  $y = 0$  midway between the plates and assuming the length of plates in the x direction is L m

(i) derive the equation for the velocity profile as

$$v_x = \frac{(P_0 - P_L)y_0^2}{2\mu L} \left[ 1 - \left( \frac{y}{y_0} \right)^2 \right]$$

Assume the width of each plate is W m

(ii) Derive the relationship between  $v_{x\text{max}}$  and  $v_{x\text{avg}}$ .

5. (a) An incompressible fluid is in steady fully developed laminar flow through a horizontal circular pipe in the z direction. Simplify the Navier-Stokes equations in conjunction with the equation of continuity to derive the differential equation for the velocity. Do not solve the equation but include all the necessary postulates.

(b) An oil having a density of  $830 \text{ kg/m}^3$  and a viscosity of  $3.3 \times 10^{-3} \text{ Pa}\cdot\text{s}$  is pumped from an open tank to a pressurised tank held at 345 kPa gauge. The oil is pumped from an inlet at the side of the open tank through a line of commercial steel pipe having an inside diameter of 0.08 m, ( $\epsilon/D = 6 \times 10^{-4}$ ), at the rate of  $3.5 \times 10^{-3} \text{ m}^3/\text{s}$ . The length of straight pipe is 122 m and the pipe contains two  $90^\circ$  elbows and a half open gate valve. The level of the liquid in the open tank is 20 m above the liquid level in the pressurised tank. The pump efficiency is 65 %. **Calculate** the kW power of the pump. Neglect the changes in kinetic energy.

$$\begin{aligned}
L_e/D \text{ for each } 90^\circ \text{ elbow} &= 35 \\
L_e/D \text{ for the half open gate valve} &= 225 \\
g &= 9.807 \text{ m}^2/\text{s} \\
h_L &= 2 f_f \frac{L}{D} \frac{v^2}{g}
\end{aligned}$$

6. (a) A furnace is constructed with 225 mm of firebrick, 120 mm of insulating brick and 225 mm of building brick. The inside temperature of the firebrick is 1200 K and the outside temperature of the building brick is 330 K. If the thermal conductivities are 1.4, 0.2 and 0.7 W/(m)(K) respectively, find the heat loss per unit area and the temperature at each junction of the bricks.
- (b) A 150 mm internal diameter steam pipe, carrying steam at 444 K, is lagged with 50 mm of 85 % magnesia ( $k = 0.073 \text{ W}/(\text{m})(\text{K})$ ). The heat transfer coefficient on the outside surface of the lagging is  $10 \text{ W}/(\text{m})(\text{K})$ . What will be the heat loss per metre to the air at 294 K? **Calculate** the surface temperature of the lagging. Neglect the resistance of the steam and the pipe wall. The thickness of the pipe wall is 0.009 m.
7. (a) Ammonia gas is diffusing at a constant rate through a layer of stagnant air 1 mm thick. Conditions are fixed so that the gas contains 50 % by volume at one boundary of the stagnant layer. The ammonia diffusing to the other boundary is quickly absorbed and the concentration is negligible at that plane. The temperature is 295 K and the pressure atmospheric. Under these conditions the diffusivity of ammonia in air is  $0.18 \text{ cm}^2/\text{s}$ . Calculate the rate of diffusion of ammonia through the layer in  $\text{kmol}/(\text{m}^2)(\text{s})$ .
- (b) Suppose the total pressure is increased to 2 atmospheres. Determine by what percentage the rate of diffusion would be increased or decreased. The diffusivity of ammonia can be assumed to be inversely proportional to the absolute pressure. The other information remains the same.

$$\begin{aligned}
\text{The gas constant } R &= 82.057 \text{ (m}^3\text{)(atm)/(kmol)(K)} \\
1 \text{ atmosphere pressure} &= 101.3 \text{ kPa}
\end{aligned}$$

---

END OF EXAMINATION IN MM451

# APPENDIX E

## THE NAVIER-STOKES EQUATIONS FOR CONSTANT $\rho$ AND $\mu$ IN CARTESIAN, CYLINDRICAL, AND SPHERICAL COORDINATES

---

### CARTESIAN COORDINATES

---

*x direction*

$$\rho \left( \frac{\partial v_x}{\partial t} + v_x \frac{\partial v_x}{\partial x} + v_y \frac{\partial v_x}{\partial y} + v_z \frac{\partial v_x}{\partial z} \right) = -\frac{\partial P}{\partial x} + \rho g_x + \mu \left( \frac{\partial^2 v_x}{\partial x^2} + \frac{\partial^2 v_x}{\partial y^2} + \frac{\partial^2 v_x}{\partial z^2} \right) \quad (\text{E-1})$$

*y direction*

$$\rho \left( \frac{\partial v_y}{\partial t} + v_x \frac{\partial v_y}{\partial x} + v_y \frac{\partial v_y}{\partial y} + v_z \frac{\partial v_y}{\partial z} \right) = -\frac{\partial P}{\partial y} + \rho g_y + \mu \left( \frac{\partial^2 v_y}{\partial x^2} + \frac{\partial^2 v_y}{\partial y^2} + \frac{\partial^2 v_y}{\partial z^2} \right) \quad (\text{E-2})$$

*z direction*

$$\rho \left( \frac{\partial v_z}{\partial t} + v_x \frac{\partial v_z}{\partial x} + v_y \frac{\partial v_z}{\partial y} + v_z \frac{\partial v_z}{\partial z} \right) = -\frac{\partial P}{\partial z} + \rho g_z + \mu \left( \frac{\partial^2 v_z}{\partial x^2} + \frac{\partial^2 v_z}{\partial y^2} + \frac{\partial^2 v_z}{\partial z^2} \right) \quad (\text{E-3})$$

---

### CYLINDRICAL COORDINATES

---

*r direction*

$$\begin{aligned} \rho \left( \frac{\partial v_r}{\partial t} + v_r \frac{\partial v_r}{\partial r} + \frac{v_\theta}{r} \frac{\partial v_r}{\partial \theta} - \frac{v_\theta^2}{r} + v_z \frac{\partial v_r}{\partial z} \right) \\ = -\frac{\partial P}{\partial r} + \rho g_r + \mu \left[ \frac{\partial}{\partial r} \left( \frac{1}{r} \frac{\partial}{\partial r} (r v_r) \right) + \frac{1}{r^2} \frac{\partial^2 v_r}{\partial \theta^2} - \frac{2}{r^2} \frac{\partial v_\theta}{\partial \theta} + \frac{\partial^2 v_r}{\partial z^2} \right] \end{aligned} \quad (\text{E-4})$$

$\theta$  direction

$$\begin{aligned} & \rho \left( \frac{\partial v_\theta}{\partial t} + v_r \frac{\partial v_\theta}{\partial r} + \frac{v_\theta}{r} \frac{\partial v_\theta}{\partial \theta} + \frac{v_r v_\theta}{r} + v_z \frac{\partial v_\theta}{\partial z} \right) \\ & = -\frac{1}{r} \frac{\partial P}{\partial \theta} + \rho g_\theta + \mu \left[ \frac{\partial}{\partial r} \left( \frac{1}{r} \frac{\partial}{\partial r} (r v_\theta) \right) + \frac{1}{r^2} \frac{\partial^2 v_\theta}{\partial \theta^2} + \frac{2}{r^2} \frac{\partial v_r}{\partial \theta} + \frac{\partial^2 v_\theta}{\partial z^2} \right] \end{aligned} \quad (\text{E-5})$$

$z$  direction

$$\begin{aligned} & \rho \left( \frac{\partial v_z}{\partial t} + v_r \frac{\partial v_z}{\partial r} + \frac{v_\theta}{r} \frac{\partial v_z}{\partial \theta} + v_z \frac{\partial v_z}{\partial z} \right) \\ & = -\frac{\partial P}{\partial z} + \rho g_z + \mu \left[ \frac{1}{r} \frac{\partial}{\partial r} \left( r \frac{\partial v_z}{\partial r} \right) + \frac{1}{r^2} \frac{\partial^2 v_z}{\partial \theta^2} + \frac{\partial^2 v_z}{\partial z^2} \right] \end{aligned} \quad (\text{E-6})$$

#### §B.4 THE EQUATION OF CONTINUITY<sup>a</sup>

$$[\partial \rho / \partial t + (\nabla \cdot \rho \mathbf{v}) = 0]$$

Cartesian coordinates ( $x, y, z$ ):

$$\frac{\partial \rho}{\partial t} + \frac{\partial}{\partial x} (\rho v_x) + \frac{\partial}{\partial y} (\rho v_y) + \frac{\partial}{\partial z} (\rho v_z) = 0 \quad (\text{B.4-1})$$

Cylindrical coordinates ( $r, \theta, z$ ):

$$\frac{\partial \rho}{\partial t} + \frac{1}{r} \frac{\partial}{\partial r} (\rho r v_r) + \frac{1}{r} \frac{\partial}{\partial \theta} (\rho v_\theta) + \frac{\partial}{\partial z} (\rho v_z) = 0 \quad (\text{B.4-2})$$

Spherical coordinates ( $r, \theta, \phi$ ):

$$\frac{\partial \rho}{\partial t} + \frac{1}{r^2} \frac{\partial}{\partial r} (\rho r^2 v_r) + \frac{1}{r \sin \theta} \frac{\partial}{\partial \theta} (\rho v_\theta \sin \theta) + \frac{1}{r \sin \theta} \frac{\partial}{\partial \phi} (\rho v_\phi) = 0 \quad (\text{B.4-3})$$

<sup>a</sup> When the fluid is assumed to have constant mass density  $\rho$ , the equation simplifies to  $(\nabla \cdot \mathbf{v}) = 0$ .

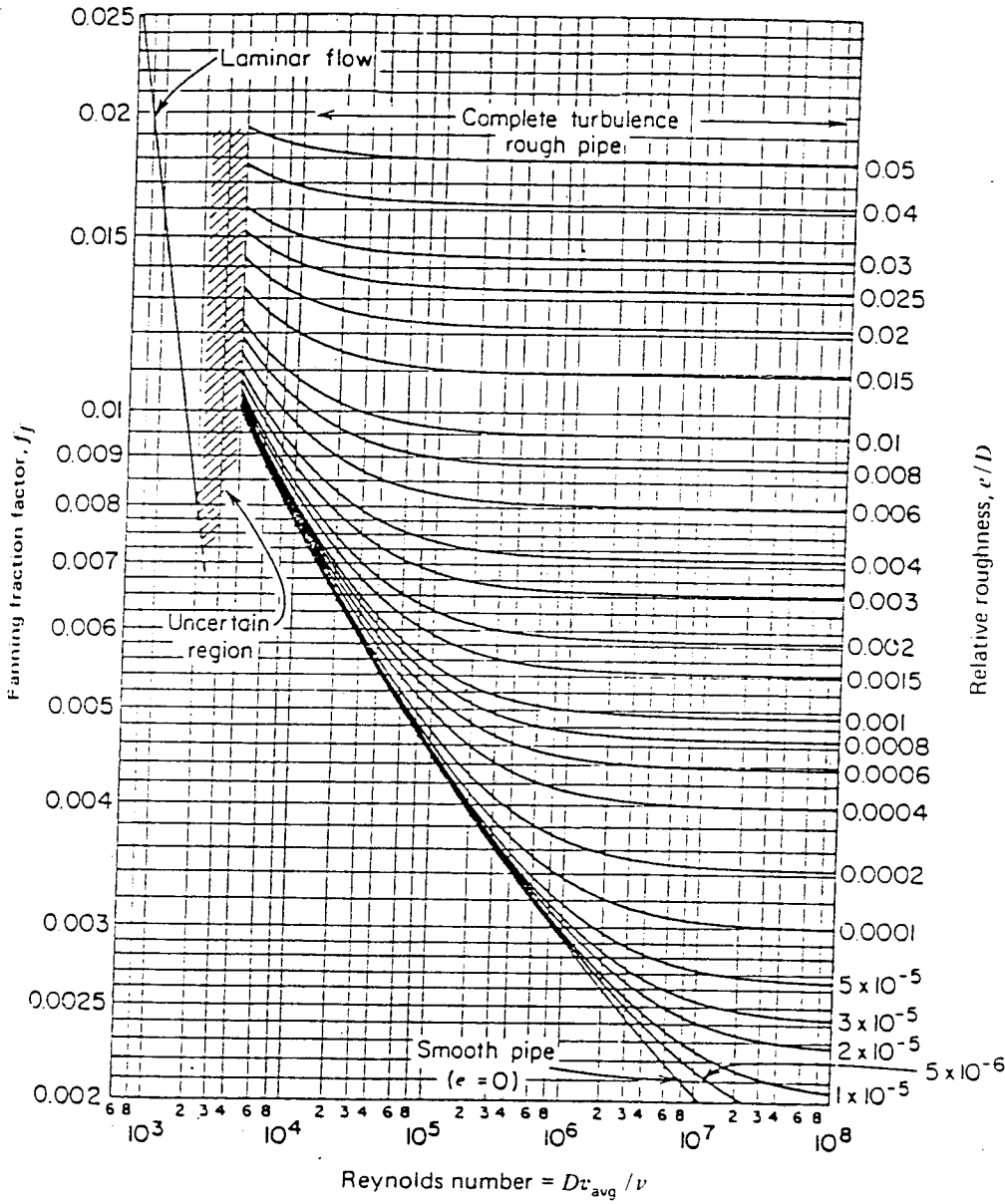

Figure 14.1 The Fanning friction factor as a function of  $Re$  and  $D/e$ .

**THE UNIVERSITY OF ZAMBIA**

**UNIVERSITY EXAMINATIONS – JUNE/JULY 2004**

**MM 481:**

**FERROUS METALLURGY**

**TIME:** THREE HOURS

**ANSWER:** ALL QUESTIONS (FIVE)

---

**QUESTION ONE**

- (a) Describe the coking process during the production of metallurgical coke. [5%]
- (b) Outline six required properties for metallurgical coke. [3%]
- (c) What are the other three fuels that are used in the Blast Furnace? [1.5%]
- (d) With the aid of a diagram describe five main operating parts of the Blast Furnace [5%]
- (e) Reactions in the Blast Furnace can take place using the following routes:
- (i) Gaseous reduction [2%]
  - (ii) Reduction by solid carbon [1%]
  - (iii) High temperature reactions [2.5%]

Describe the reactions that take place in the above routes.

**QUESTION TWO**

- (a) Write the formula for calculating the productivity of a sintering machine, describe the symbols and their units [4%]
- (b) In an Iron and steelmaking plant, where you have been taken on as a Trainee Metallurgist, the sintering section consisting of 5 sintering strands each of 175 m<sup>2</sup> surface area has only 4 strands in operation at a time. The sintering operates for 20 hours per working day. If the productivity of one sintering machine is 195 t/hour, and that 10% of sinter delivered to the Blast Furnace is returned back after sieving.

Calculate:

- (i) the vertical velocity of a sintering machine in this plant [5%]
- (ii) the length of sintering strand used in this plant [5%]
- (iii) the amount of pig iron produced by the Blast Furnace per working day, if it consumes 1.75 tonnes sinter per tonne of pig iron produced. [6%]

Productivity factor = 60%

Bulk density of sinter =  $1.6 \text{ t/m}^3$

Height of sinter layer (H) = 400 mm

Speed of strand (speed) = 2 m/min

### QUESTION THREE

- (a) Give three general requirements of steel for continuous casting [3%]
- (b) With the aid of a sketch describe the progress of solidification in the mould during continuous casting [5%]
- (c) Describe the requirements that cause the interposition of a tundish between the ladle and casting mould. [3%]
- (d) Why is it necessary to protect steel from reoxidation during casting? [1%]
- (e) With the aid of a diagram show three potential areas where re-oxidation of steel can take place during continuous casting. [3%]
- (f) Give four objectives for lubricating the mould top in Open Stream casting. [5%]

### QUESTION FOUR

- (a) Carbon in steelmaking is described as 'the Chief Controller' of steel properties. Describe FIVE types of steel with carbon contents ranging from 0.05 to 0.65%. [5%]
- (b) What is the effect of hydrogen in steel and how can it be reduced? [2%]
- (c) Describe five benefits of vacuum degassing. [5%]
- (d) For ingot moulds, why is it possible to use cast iron with a melting point much lower than that of steel. [2%]
- (e) Describe the formation of open Top in killed steel ingots and how they can be controlled. [6%]

### **QUESTION FIVE**

- (a) Outline five most important reasons for cleaning gases from metallurgical processing. [5%]
- (b) Dust collecting is done by a variety of methods, with the method chosen taking into account various factors. Name five of these factors. [3%]
- (d) Describe the operation of the following dust collectors (i) Settling Chamber (ii) Electrostatic precipitator (iii) Spray Tower [9%]
- (e) Gases from metallurgical processes are dissipated through tall stacks. Describe three conditions that may result in gas dissipation through tall stacks. [3%]
- 

**END OF EXAMINATION IN MM 481**

**UNIVERSITY OF ZAMBIA**

**UNIVERSITY EXAMINATIONS – JUNE/JULY 2004**

**MM 515**

**SPECIAL TOPICS IN MINERAL PROCESSING.**

**TIME:** THREE hours

**ANSWER:** FIVE questions  
All questions carry equal marks

---

**QUESTION ONE**

A quantity of ore containing chalcopyrite ( $\text{CuFeS}_2$ ) is going to be used in preliminary flotation studied. The total amount of material available is 20 kg. To determine the assay of the ore 200g is carefully removed and reduced to 100% passing 75  $\mu\text{m}$  before extracting 2g sub-sample on which chemical analysis is to be done. The ore is found to contain 3.14% Cu. Determine at 95% confidence level the combined error limits on the head assay assuming the analytical error to be zero. The largest piece in the ore is 6.35mm and the richest piece is visually estimated to be 75% chalcopyrite. Densities of the mineral and the gangue are 4.2 and 2.7 respectively. Take the shape factor and size factor as 0.5 and 0.25 respectively.

**QUESTION TWO**

- (a) What are the main advantages of using particle size distribution functions as compared to other methods of presenting sizing data?
- (b) Give the general equation of particle size distribution function and outline the significance of the various parameters with reference to the Guadin-Schulmann and Rosin–Rammler functions. Show how these two functions are related.
- (c) A particle size distribution of the ore is known to follow the G.S. function with 90% and 50% of the particle being less than 1mm and 0.5mm respectively. What is the weight percent between 10  $\mu\text{m}$  and 20  $\mu\text{m}$ ?

### QUESTION THREE

- (a) Explain how an electrical double layer may be formed when minerals are put in a solution:
- (b) What do you understand by the following terms?
- Electrophoresis
  - Streaming potential
  - Electro osmosis
  - Sedimentation Potential

How can you measure the first two and give detailed explanation of how Electrophoresis will lead to establishing the zeta potentials and explain how this may be use in the separation of different minerals.

### QUESTION FOUR

What is the purpose of particle size reduction in mineral processing?

- (i) Give the various definitions of “Reduction Ratio” and identify the most important definitions.
- (ii) In Energy-Size reduction relationships as used in the design of comminution equipment, empirical “laws” are normally used. Name these laws and explain on which basis each one is used. Using a generalised equation derive each on of them.
- (iii) What do you understand by the term “Bond index”?

### QUESTION FIVE

- (a) “Only regular geometrical shapes can have their sizes conveniently qualified”. Discuss the implications of this statement with regards to:
- (i) The various definition of “size”
  - (ii) Applications of these definitions size.
- (b) Discuss the principle involved in incremental methods and show how the data obtained may be useful.
- (c) Describe the Andreassen pipette and the interpretation/calculation of results. What are the main disadvantages of this apparatus?

### QUESTION SIX

The following data refer to the adsorption of n-butane at 273 K by a sample of tungsten powder which has a specific surface area (as determined from nitrogen adsorption measurements at 77 K) of  $6.5 \text{ m}^2\text{g}^{-1}$ :

Relative pressure ( $p/p_0$ )	0.04	0.10	0.16	0.25	0.30	0.37
Volume of gas adsorbed/ $\text{cm}^3$ (s.t.p.) $\text{g}^{-1}$	0.33	0.46	0.54	0.64	0.70	0.77

Use the BET equation to calculate a molecular area for the adsorbed butane at monolayer coverage and compare it with the value of  $32.1 \times 10^{-20} \text{ m}^2$  estimated from the density of liquid butane. Explain the reasons for having two different values.

BET Equation can be written as

$$\frac{p}{n(p_0 - p)} = \frac{1}{n_m C} + \frac{(C-1)}{n_m C} \left( \frac{p}{p_0} \right)$$

---

**END OF EXAMINATION IN MM 515**

# Appendix B Statistical tables

Table 1 Areas under the normal curve

	.00	.01	.02	.03	.04	.05	.06	.07	.08	.09
0.0	.5000	.5040	.5080	.5120	.5160	.5199	.5239	.5279	.5319	.5359
.1	.5398	.5438	.5478	.5517	.5557	.5596	.5636	.5675	.5714	.5753
.2	.5793	.5832	.5871	.5910	.5948	.5987	.6026	.6064	.6103	.6141
.3	.6179	.6217	.6255	.6293	.6331	.6368	.6406	.6443	.6480	.6517
.4	.6554	.6591	.6628	.6664	.6700	.6736	.6772	.6808	.6844	.6879
.5	.6915	.6950	.6985	.7019	.7054	.7088	.7123	.7157	.7190	.7224
.6	.7257	.7291	.7324	.7357	.7389	.7422	.7454	.7486	.7517	.7549
.7	.7580	.7611	.7642	.7673	.7703	.7734	.7764	.7793	.7823	.7852
.8	.7881	.7910	.7939	.7967	.7995	.8023	.8051	.8078	.8106	.8133
.9	.8159	.8186	.8212	.8238	.8264	.8289	.8315	.8340	.8365	.8389
1.0	.8413	.8438	.8461	.8485	.8508	.8531	.8554	.8577	.8599	.8621
1.1	.8643	.8665	.8686	.8708	.8729	.8749	.8770	.8790	.8810	.8830
1.2	.8849	.8869	.8888	.8906	.8925	.8943	.8962	.8980	.8997	.9015
1.3	.9032	.9049	.9066	.9082	.9099	.9115	.9131	.9147	.9162	.9177
1.4	.9192	.9207	.9222	.9236	.9251	.9265	.9279	.9292	.9306	.9319
1.5	.9332	.9345	.9357	.9370	.9382	.9394	.9406	.9418	.9429	.9441
1.6	.9452	.9463	.9474	.9484	.9495	.9505	.9515	.9525	.9535	.9545
1.7	.9554	.9564	.9573	.9582	.9591	.9599	.9608	.9616	.9625	.9633
1.8	.9641	.9648	.9656	.9664	.9671	.9678	.9686	.9693	.9699	.9706
1.9	.9713	.9719	.9726	.9732	.9738	.9744	.9750	.9756	.9761	.9767
2.0	.9772	.9778	.9783	.9788	.9793	.9798	.9803	.9808	.9812	.9817
2.1	.9821	.9826	.9830	.9834	.9838	.9842	.9846	.9850	.9854	.9857
2.2	.9861	.9864	.9868	.9871	.9875	.9878	.9881	.9884	.9887	.9890
2.3	.9893	.9896	.9898	.9901	.9904	.9906	.9909	.9911	.9913	.9916
2.4	.9918	.9920	.9922	.9924	.9927	.9929	.9930	.9932	.9934	.9936
2.5	.9938	.9940	.9941	.9943	.9945	.9948	.9948	.9949	.9951	.9952
2.6	.9953	.9955	.9956	.9957	.9959	.9960	.9961	.9962	.9963	.9964
2.7	.9965	.9966	.9967	.9968	.9969	.9970	.9971	.9972	.9973	.9974
2.8	.9974	.9975	.9976	.9977	.9977	.9978	.9979	.9979	.9980	.9981
2.9	.9981	.9982	.9982	.9983	.9984	.9984	.9985	.9985	.9986	.9986
3.0	.9986	.9987	.9987	.9988	.9988	.9989	.9989	.9989	.9990	.9990
3.1	.9990	.9991	.9991	.9991	.9992	.9992	.9992	.9992	.9993	.9993
3.2	.9993	.9993	.9994	.9994	.9994	.9994	.9994	.9995	.9995	.9995
3.3	.9995	.9995	.9995	.9996	.9996	.9996	.9996	.9996	.9996	.9996
3.4	.9997	.9997	.9997	.9997	.9997	.9997	.9997	.9997	.9997	.9998
3.5	.9998	.9998	.9998	.9998	.9998	.9998	.9998	.9998	.9998	.9998
3.6	.9998	.9998	.9998	.9999	.9999	.9999	.9999	.9999	.9999	.9999

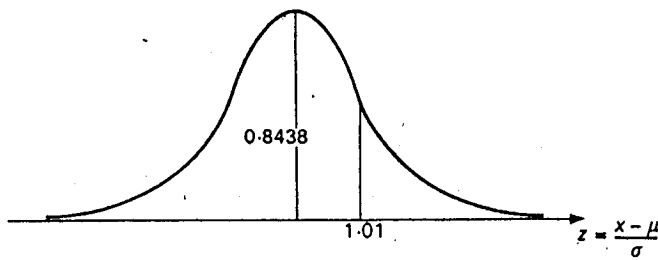

**THE UNIVERSITY OF ZAMBIA**  
**UNIVERSITY EXAMINATIONS – JUNE 2004**  
**SELECTED TOPICS IN EXTRACTIVE METALLURGY**

**MM545**

**TIME:** Three Hours

**Answer:** Five Questions, Question Six is compulsory

---

**Question 1**

- a) What is scrap? What is the importance of metal recycling?  
Name and describe the various types of scrap used in steelmaking.  
What are tramp elements? What effect do they have on the quality of Steel? Name each element.
- b) Describe the methods of recycling of the following metals:  
Copper, Zinc and Gold.

**Question 2**

- a) Construct a Stability or Predominance equilibrium diagram for the roasting of Chalcopyrite –  $\text{CuFeS}_2$  at 1000K. Discuss the sequence of reactions from point A to D through B and C. Name the equilibrium phases that form during the roasting operation.
- b) Draw and discuss the ternary phase diagram for the system  $\text{FeO} - \text{FeS} - \text{SiO}_2$  at 1300 degrees Celsius and 1 atmosphere pressure.

**Question 3**

- a) Discuss briefly but clearly the INCO and the Kennecott solid matte oxygen converting (SMOC) processes for the production of copper. What are the fundamental differences between the two processes?
- b) Give a definition of the Process Fuel Equivalent (PFE) according to Kellogg and Henderson
- c) Discuss the effect of oxygen enrichment and matte grade on the fuel ratio for all the autonomous smelting processes.

**Question 4**

- a) Describe the kinetics of solvent extraction (SX) in the recovery of Uranium and Copper from their ores.
- b) Discuss in detail the cementation of copper by iron and the type of Equipment used.

**Question 5**

- a) Describe the production of sulphuric acid (H<sub>2</sub>SO<sub>4</sub>) and elemental sulphur from smelter flue gases. What reasons dictate the recovery of SO<sub>2</sub> from such gases.
- b) Governments the world over have passed laws limiting the SO<sub>2</sub> emissions into the atmosphere, indicate what limits these are.
- c) How do the following gas cleaning equipment operate:
  - i) Electrostatic precipitators, and
  - ii) Filters

**Question 6**

- (a) From the table given below, calculate the values of the parameters given as model variables and also their corresponding quantities as inputs to the blast furnace. What is the top gas composition?

Table of Cementation

Item	Specification	Quantity	Quantity	Model variables (kg moles/kg mole product Fe)
		Kg per tonne Fe	Kg moles per tonne Fe	
Fe	-	2000 / 1000	17.9	
Iron oxide	Fe <sub>2</sub> O <sub>3</sub>	?	?	$\left(\frac{O}{Fe}\right)^x = ?$
Pig iron	5%C	?	?	$\left(\frac{C}{Fe}\right)^m = ?$
Coke (only Carbon source)	90%C	500	?	$n_c^i = ?$
Active Carbon	?	?	?	$n_c^A = ?$
Oxygen from blast.		350	?	$n_o^B = ?$

Top gas composition:

$$N_2 = (\%)$$

$$CO_2 = (\%)$$

$$CO = (\%)$$

- (b) Convert the following parameters into numerical values for their equivalent blast furnace model variables.

Operating parameters	Model variable
(i) Ore charge: hematite, $Fe_2Oe_3$	$\left(\frac{O}{Fe}\right)^x$
(ii) Blast: $1200 \text{ Nm}^3$ dry air per tonne of product Fe	$n_O^B$
(iii) Pig iron: 5 % C	$\left(\frac{C}{Fe}\right)^m$
(iv) Total carbon in charge: 460 kg dry coke (90 % C) and 50 kg oil (85 % C) per tonne of Fe.	$n_c^i = n_c^o$
(v) Active carbon from (iii) and (iv)	$n_C^A$
(vi) Carbon in top gas from (v)	$n_C^g$
(vii) Top gas composition: 23.9 Vol. % CO, 20.5 % $CO_2$ , 55.6 % $N_2$	$\left(\frac{O}{C}\right)^g$
(viii) Quantity of CO and $CO_2$ in top gas from (vi) and (vii)	$n_{CO}^g, n_{CO_2}^g$

**END OF EXAMINATION IN MM545**  
**GOOD LUCK!**



5. Write short notes on the following issues.

- i) Management by objectives. **[4 marks]**
- ii) Marslow's hieracy of needs theory **[4 marks]**
- iii) Japanese "Theory Z". **[4 marks]**
- iv) The managerial grid. **[4 marks]**
- v) Managerial effectiveness **[4 marks]**

**SECTION B**

**ANSWER 2 QUESTIONS ONLY**

1. a) What factors affect the supply demand for mineral commodities? **[10 marks]**
- b) Define income elasticity of demand. **[5 marks]**
- c) Suppose that the demand function for commodity X is given by the equation:

$$Q_x = 34 - 0.8P_x^2 + 0.3P_y + 0.04I$$

Determine the price elasticity of demand for X when  $P_x = \$10$ ,  $P_y = \$20$ , and  $I = \$5,000$ . **[5 marks]**

2. The balance sheet for LOM Inc. has the following entries:

Current assets	\$6,200
Fixed assets (book value)	4,100
Other assets	300
Current liabilities	3,150
Long-term liabilities	1,150
Retained earnings	3,300

- a) What is LOM's working capital? **[5 marks]**
- b) Indicate whether the following entries belong to the Balance sheet or the Income (Profit and Loss) statement. If the entry belongs to the Balance sheet, indicate whether it is an asset (A), a liability (L), or part of owner's equity (E). **[15 marks]**

	Balance Sheet		Income Statement
	X	A	
<b>Accounts receivable</b>	<b>X</b>	<b>A</b>	
<b>Labour expenses</b>			<b>X</b>
Marketing expenses			
Depreciation			
Inventory			
Net loss			
Equipment at cost			
Taxes payable			
Mortgage bonds			
Common stock			
Accumulated depreciation			
Earned surplus			
Interest paid			
Cost of goods sold			
Marketable securities			
Prepaid expenses			
Investments in subsidiaries			

3. Consider two projects having the following cash flows:

Year	A	B
0	-30,000	-30,000
1	17,000	9,000
2	13,000	10,000
3	8,000	12,000
4	6,000	17,000

Minimum acceptable rate of return is 10%

- Calculate the net present value of each project and which is the preferred alternative? **[6 marks]**
- Find each project's internal rate of return (IRR). What is the best alternative using the IRR criterion? **[8 marks]**
- Determine the equivalent annual value of project A. **[6 marks]**

**THE END OF EXAMINATIONS**