

**UNIVERSITY OF ZAMBIA**  
**TABLE OF CONTENTS**  
**SCHOOL OF ENGINEERING**

1. AEN 4311: Farm Power
2. CEF 3222: Theory of Structures
3. CEE 3311: Fluid Mechanics
4. CEE 3711: Soil Science & Hydrology
5. CEE 4211: Design in Unreinforced Masonery
6. CEE 4311: Hydrology
7. CEE 4412: Environmental Engineering 1
8. CEE 4612: Highway and Traffic Engineering
9. EEE 3112: Electrical Engineering Praticce
10. EEE 3352: Electromachanics and Electrical Machines
11. EEE 3571: Eletronic Engineering I
12. EEE 4021: Engineering Electromagnetics
13. EEE 4135: Microcontroller Technology and Embedded Systems
14. EEE 4221: Digital Signal Processing
15. EEE 4571: Electronic Engineering II
16. EEE 4682: Communication Principles
17. GEE 4812: Principles of Geomatics
18. GGY 3051: Engineering Geology
19. MEC 2009: Engineering Drawing I
20. MEC 2309: Properties of Engineering Materials I
21. MEC 3102: Production Engineering I, Electricity & Electronic II
22. MEC 3352: Strength of Materials II
23. MEC 3401: Thermodynamics
24. MEC 4055: Machine Design I
25. MEC 4055: Machine Design I- Paper II
26. MEC 4105: Production Technology I
27. MEC 4601: Fluid Mechanics II

**THE UNIVERSITY OF ZAMBIA**  
**SCHOOL OF ENGINEERING**  
**DEPARTMENT OF AGRICULTURAL ENGINEERING**  
**UNIVERSITY EXAMINATIONS**  
**NOVEMBER 2021**  
**AEN 4311 (FARM POWER)**

**TIME ALLOWED: THREE HOURS**

**INSTRUCTIONS:**

1. READ ALL THE QUESTIONS CAREFULLY
2. THIS EXAMINATION PAPER HAS **TWO** SECTIONS, **SECTION A**, AND **SECTION B**.
3. **SECTION A** HAS **TWENTY** MULTIPLE CHOICE QUESTIONS. ATTEMPT **ALL** QUESTIONS IN THIS SECTION. EACH QUESTION HAS **TWO MARKS**.
4. **SECTION B** HAS **SIX** QUESTIONS. ATTEMPT **THREE** QUESTIONS ONLY. EACH QUESTION CARRIES **20 MARKS**.
5. MARKS ALLOCATED FOR EACH SUB-QUESTION IN SECTION B ARE INDICATED IN BRACKETS.
6. START EACH QUESTION IN **SECTION B** ON A NEW PAGE.
7. CLEARLY INDICATE THE SECTIONS IN THE ANSWER BOOKLET AND NUMBER THE ANSWERS CORRECTLY ACCORDING TO THE NUMBERING SYSTEM USED IN THIS QUESTION PAPER.
8. SHOW ALL CALCULATIONS AND UNITS. ROUND OFF FINAL ANSWERS TO TWO DECIMAL PLACES.
9. WRITE NEATLY AND LEGIBLY.
10. WRITTEN MATERIALS, CELL PHONES AND PROGRAMMABLE CALCULATORS ARE **NOT ALLOWED** IN THE EXAMINATION ROOM.

**DO NOT TURN THE PAGE UNTIL YOU ARE TOLD TO DO SO!**

**SECTION A (20 MARKS): ATTEMPT ALL QUESTIONS IN THIS SECTION**

**For each of the following questions, choose the BEST answer and write in the answer booklet, in capital letters, the letter corresponding to your answer.**

1. The generic term for muscles responsible for bending a joint is ...
  - a) extensor muscles
  - b) flexor muscles
  - c) biceps
  - d) triceps.
  
2. Glucose is converted to \_\_\_\_\_ for short-term storage and \_\_\_\_\_ for long-term storage.
  - a) pyruvic acid, fat
  - b) glycogen, fat
  - c) protein, glycogen
  - d) fat, pyruvic acid
  
3. Given these phases of aerobic respiration:
  1. acetyl-coenzyme A formation
  2. citric acid cycle
  3. electron-transport chain
  4. glycolysisList the phases in the order they occur, as a molecule of glucose is broken down during energy metabolism in the body.
  - a) 1,4,2,3
  - b) 4,1,2,3
  - c) 2,1,4,3
  - d) 3,2,4,1
  
4. Anaerobic energy metabolism refers to the generation of ATP ...
  - a) without the use of glycogen
  - b) without the use of oxygen
  - c) in the absence of oxygen
  - d) by the conversion of pyruvate to lactic acid
  
5. Chemical reactions that break down complex molecules into simpler ones are called ....
  - a) Anabolic reactions
  - b) Catabolic reactions
  - c) Metabolic reactions
  - d) Oxidation reactions
  
6. Creatine Phosphate is a high-energy phosphate compound that is used in the cell .....
  - a) to transport ATP to the mitochondria.
  - b) to resynthesize ATP from ADP.
  - c) as a direct source of energy for the cell.
  - d) as a rate-limiting enzyme in the metabolism of fat and carbohydrate.

7. What is not true about a six cylinder in-line four stroke cycle engine?
- the cycle is completed in two revolutions of crankshaft rotation.
  - cylinder No. 2 and Cylinder No. 4 are at Top Dead Centre at the same time.
  - adjacent power strokes overlap by  $60^\circ$
  - the firing interval is  $120^\circ$
8. What event is characterised by closed intake and exhaust valves and the movement of the piston from BDC to TDC in a four stroke cycle engine?
- Induction stroke
  - Compression stroke
  - Exhaust stroke
  - Power stroke
9. An engine has a cylinder displacement to clearance volume ratio of 14.5. The engine compression ratio is ...
- 13.5
  - 15.5
  - 14.5
  - impossible to determine
10. The break power of an engine is always ..... the indicated power
- Equal to
  - Less than
  - Greater than
  - None of the above
11. The operation of forcing additional air under pressure in the engine cylinder is known as
- Supercharging
  - Scavenging
  - Turbulence
  - Pre-ignition
12. The ignition quality of petrol is expressed by
- Octane number
  - Cetane number
  - Calorific value
  - All of the above
13. The mean effective pressure obtained from engine indicator diagram indicates the ...
- average pressure during the cycle
  - maximum pressure during the cycle
  - minimum pressure during the cycle
  - instantaneous pressure at any instant during the cycle

14. Figure Q14 below shows the firing order diagram for a four cylinder four stroke cycle engine.

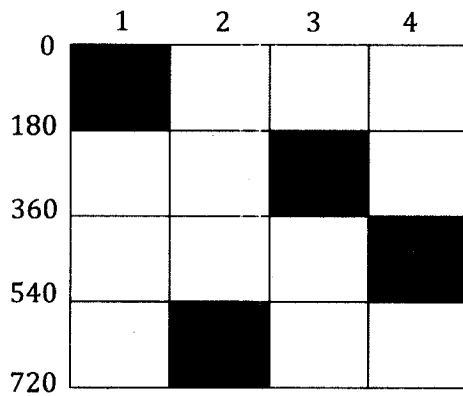

Figure Q14 Firing order diagram for a four cylinder four stroke cycle engine.

When cylinder 1 is on compression stroke, what event is taking place simultaneously in cylinder 4?

- Exhaust stroke
  - Power stroke
  - Compression stroke
  - Induction stroke
15. In a four cylinder two stroke cycle engine there is one power stroke every \_\_\_\_\_ of crankshaft rotation.
- 90°
  - 120°
  - 180°
  - 360°
16. The process of breaking up of higher hydrocarbon molecules into lower hydrocarbons having lower boiling temperatures is known as
- Cracking
  - Polymerization
  - Hydrogeneration
  - Isomerization
17. A mixture of theoretical air and fuel for complete combustion of fuel is called
- Stoichiometric mixture
  - Rich mixture
  - Lean mixture
  - Air-fuel mixture
18. If a four cylinder four stroke cycle petrol engine is running at 2000 rpm, the speed of the camshaft would be ...
- 500 rpm
  - 1000 rpm
  - 2000 rpm
  - 4000 rpm

19. In which one of the following thermodynamic process, is there no heat exchange with the surroundings?
- a) Isobaric
  - b) Isochoric
  - c) Isothermal
  - d) Adiabatic
20. A four cylinder four stroke cycle diesel engine has 3000 power strokes per minute; its speed is ...
- a) 750 rpm
  - b) 1500 rpm
  - c) 3000 rpm
  - d) 6000 rpm

**SECTION B: (60 MARKS) THIS SECTION HAS SIX QUESTIONS. ATTEMPT THREE QUESTIONS ONLY. EACH QUESTION HAS 20 MARKS.**

**QUESTION 1**

- a) Briefly explain why oxen are preferred to bulls for providing draft power for field work. [2 marks]
- b) A pair of oxen, each weighing 500 kg is used to plough a field. The plough cuts furrow slices that are 20cm wide by 12.5cm deep. The specific soil resistance is  $5\text{N/cm}^2$  and the oxen have a working speed of 4.32 km/h. The oxen work for 6 hours per day and they are fed on Sudan grass which has a gross energy of 17.0 MJ/kg of dry matter and DE/GE ratio of 0.65. Given the following additional information:
- Maintenance Energy =  $8.3 + (0.091W)$  MJ/day, Where W is the mass of the draft animal
  - Appetite Limit =  $0.025W$  kg of dry matter
  - Metabolisable Energy (ME) = 0.8 of Digestible Energy (DE)
  - Energy Conversion Efficiency of Draft Animals = 20%
- i) Calculate the power, P, required to pull the plough. [1 marks]
- ii) Calculate the amount of energy, E, (in MJ) needed to plough the field per day. [2 marks]
- iii) Calculate the maintenance energy,  $ME_{MR}$ , for a pair of oxen. [2 marks]
- iv) Calculate the amount of metabolisable energy,  $ME_{WD}$ , needed to plough the field per day. [2 marks]
- v) Calculate the total daily metabolisable energy,  $ME_{Tot}$ , requirement (for maintenance and work) for a pair of oxen. [2 marks]
- vi) Calculate the quantity of Sudan grass (in kg) needed to meet the total daily energy requirement for a pair of oxen. [2 marks]
- vii) Calculate the appetite limit for a pair of oxen. [1 marks]
- viii) Show that the oxen need supplementary feed. [2 marks]
- ix) State two important characteristics of feed that must be taken into account in selecting the supplementary feed. [2 marks]
- x) Calculate the quantity of groundnut cake supplement that would be required per ox per day to meet the total daily energy requirement during the time that the oxen are used to plough the field? Groundnut cake has gross energy of 20.7 MJ/kg of dry matter and DE/GE ratio of 0.85 [2 marks]

## **QUESTION 2**

- a) State **three** physical differences between a two stroke cycle petrol engine and a two stroke cycle diesel engine. **[6 marks]**
- b) A four-cylinder Perkins engine has a 127.0 mm stroke and 107.9 mm bore. According to the engine specifications, the compression ratio for the engine is 16:1. While overhauling the engine, a mechanic unintentionally installed a cylinder head gasket that is 1.25 mm thicker than the recommended gasket.
- i) What is the function of a cylinder head gasket on an engine? **[2 marks]**
- ii) Calculate the cylinder displacement,  $V_d$ , the clearance volume,  $V_c$ , and the maximum cylinder volume,  $V_t$ . **[6 marks]**
- iii) Calculate the compression ratio of the engine with the thicker cylinder head gasket installed. **[3 marks]**
- c) Would the mistake made by the mechanic likely to affect the operation of the engine? Briefly explain your answer. **[3 marks]**

## **QUESTION 3**

- a) Briefly explain the following terms:
- i) Stoichiometric air to fuel ratio
- ii) Excess air factor ( $\lambda$ ) **[4 marks]**
- b) Write balanced equations for complete combustion of the following fuels and calculate their respective stoichiometric air to fuel ratios:
- i) Petrol ( $C_8H_{18}$ )
- ii) Ethanol ( $C_2H_5OH$ ) **[8 marks]**
- c) Briefly explain the adjustment required to an engine that currently uses petrol fuel, if it has to switch to ethanol as engine fuel. **[3 marks]**
- d) What is the difference between an engine that is used in determining the Octane Number of petrol fuels from an ordinary petrol engine? **[2 marks]**
- e) Name the reference fuels used in determining the Octane Number of petrol fuel and state their corresponding Octane Numbers. **[3 marks]**

#### QUESTION 4

- a) State **two** major functions of each of the following components of the power train:
- transmission (gearbox)
  - differential

[4 marks]

- b) Figure Q4 below shows the tractor power train.

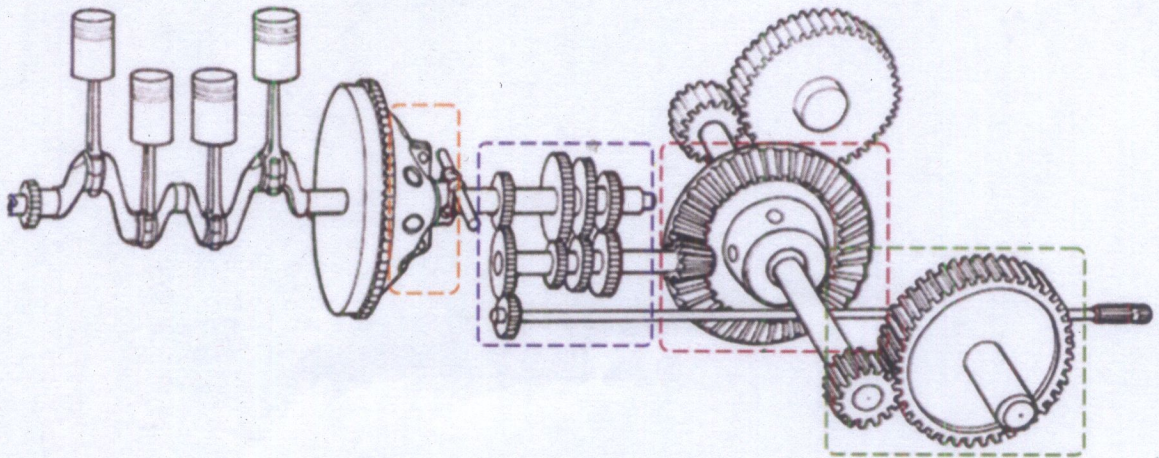

**Figure Q4. Tractor power train**

#### Differential specification

Number of gear teeth on the differential bevel pinion gear = 16

Number of gear teeth on the differential ring gear = 128

#### Final Drive specification

Number of gear teeth on the final drive pinion gear = 18

Number of gear teeth on the final drive spur gear = 90

- What type of sliding gear transmission is used in the power train in Figure Q4  
[2 marks]
  - Calculate the gear ratio at the differential,  $i_D$  and at the final drive,  $i_{FD}$   
[2 marks]
  - When ploughing in Gear 1 it is observed that while the engine is running at 2400 rpm, the drive wheels are rotating at 12 rpm. Calculate the transmission gear ratio in Gear 1.  
[2 marks]
  - If the tractor drive wheels have a diameter of 1.5m, calculate the tractor forward travel speed in Gear 1.  
[2 marks]
  - If the engine torque during ploughing in Gear 1 is 350 Nm and overall power train efficiency is 95%, calculate the torque at the wheels.  
[2 marks]
- c) Why is the final drive of a tractor located at the end of the power train?  
[3 marks]
- d) Briefly explain the function of a differential lock on a tractor and state two situations which may necessitate engaging the differential lock when performing field operations.  
[3 marks]

### **QUESTION 5**

- a) State the **four** conditions essential for efficient operation of a four stroke cycle internal combustion engine and briefly explain the significance of each condition. **[4 marks]**
- b) With the help of a well-labeled indicator (p-v) diagram, outline the operation of a theoretical diesel cycle engine. **[4 marks]**
- c) Give **two** reasons why the actual engine efficiency is lower than the theoretical engine efficiency. **[4 marks]**
- d) A farmer in Choma is intending to invest in a naturally aspirated diesel-engine-powered water pump for irrigation. Table Q5 shows the average monthly minimum temperature for Choma. The auto ignition temperature of diesel fuel is 387°C. The compression ratio of the engine is 17.5:1 and the polytropic constant,  $n = 1.30$ .

Table Q5: Average minimum monthly temperature for Choma.

Month	Jan	Feb	Mar	Apr	May	Jun	Jul	Aug	Sep	Oct	Nov	Dec
Avg Min. Temp (°C)	16.7	16.4	15.2	12.1	7.8	4.7	4.3	6.2	10.7	14.3	16.2	16.6

- i) During which month(s) is the farmer expected to experience hard start due to air not reaching the self-ignition temperature of the diesel fuel during compression? **[4 marks]**
- ii) State two modifications that can be made to a naturally aspirated diesel engine to reduce the chances of cold starting. **[4 marks]**

### **QUESTION 6**

- a) A John Deere 5225 tractor has a 5 cylinder, in-line, turbo-charged four stroke cycle diesel engine. The engine has an engine displacement of 3.05 litres, an 86 mm bore, 105 mm stroke and a compression ratio of 18.2:1.
- i) What is the function of a turbo-charger on an engine? **[2 marks]**
- ii) Calculate the cylinder clearance volume **[2 marks]**
- iii) Calculate the firing interval and the crank throw angle of the crankshaft between any two consecutive cylinders. **[4 marks]**

- iv) Determine the firing order and draw the firing order diagram for the engine, clearly indicating the crankshaft angle at which the power stroke begins and ends in each cylinder. **[6 marks]**
- v) Determine the overlap between any two successive power strokes. **[2 marks]**
- b) When slashing grass, the engine in (a) runs at an average speed of 2400 rpm and has a fuel consumption of 12 litres per hour.
- i) Calculate the average number of power strokes per hour. **[2 marks]**
- ii) Calculate the average volume of each fuel injection (in  $\text{mm}^3$ ). **[2 marks]**

**END OF EXAMINATION**



**UNIVERSITY OF ZAMBIA**  
**SCHOOL OF ENGINEERING**  
DEPARTMENT OF CIVIL & ENVIRONMENTAL ENGINEERING

**CEE 3222: THEORY OF STRUCTURES**

**FINAL EXAMINATION**

**DATE: 23-11-2021;**

**TIME: 09:00-12:00;**

**DURATION: 3:00 HOURS**

**INSTRUCTIONS**

1. There are a total of SEVEN (7) questions in this Exam, answer FIVE (5) questions only.
2. Section A has TWO (2) questions which are compulsory,
3. Section B has FIVE (5) questions, ANSWER ANY THREE (3).
4. Show all your working.
5. Write the computer number on the answer sheet.
6. No Extra material, the exam is not open book.
7. Marks are indicated in the square brackets at the end of each question.

**All the best, You've got this!!**

USEFUL INFORMATION

$$v = \int \int \frac{M}{EI} dx dx \quad t_{A/B} = \bar{x} \int_A^B \frac{M}{EI} dx \quad U = \frac{P^2 L}{2AE} \quad U = \frac{T^2 L}{2GJ}$$

$$U = \int_0^L \frac{M^2}{2EI} dx \quad 1 \cdot \Delta = \sum \frac{nNL}{AE} \quad 1 \cdot \Delta = \sum n\alpha \Delta T L \quad 1 \cdot \Delta = \sum n \Delta L$$

$$1 \cdot \Delta = \int_0^L \frac{mM}{EI} dx \quad DF = \frac{K}{\sum K} \quad 1 \cdot \theta = \int_0^L \frac{m_\theta M}{EI} dx \quad U_s = \int_0^L K \left( \frac{vV}{GA} \right) dx$$

$$U_{temp} = \int_0^L \frac{m\alpha \Delta T_m dx}{c} \quad \Delta = \sum N \left( \frac{\partial N}{\partial P} \right) \frac{L}{AE} \quad \Delta = \int_0^L M \left( \frac{\partial M}{\partial P} \right) \frac{dx}{EI}$$

$$\theta = \int_0^L M \left( \frac{\partial M}{\partial M'} \right) \frac{dx}{EI} \quad 0 = \theta_A + M_A \alpha_{AA} \quad 0 = -\Delta_B + B_y f_{BB}$$

$$M_N = 2Ek(2\theta_N + \theta_F - 3\psi) + (FEM)_N \quad M_N = 3Ek(\theta_N - \psi) + (FEM)_N$$

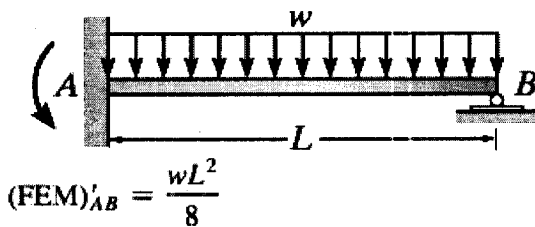
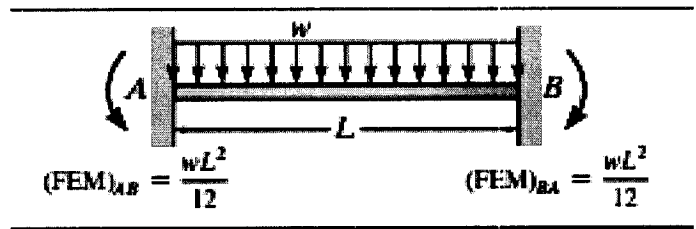
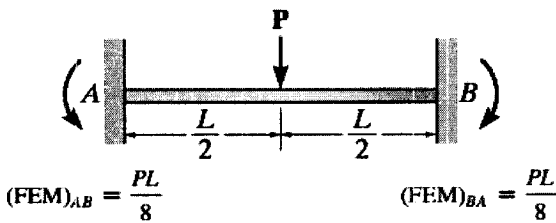

Loading	$v + \uparrow$	$\theta + \curvearrowright$
	$v_{max} = -\frac{PL^3}{3EI}$ at $x = L$	$\theta_{max} = \frac{PL^2}{2EI}$ at $x = L$

QUESTION 7:

- a. State Maxwell's Theorem of Reciprocal Displacements? [3]
- b. With the aid of the force method, determine the support reactions of the beam shown in the figure by making  $B_y$  the redundant force and draw the bending moment diagram. Note;  $EI$  is constant and that  $\Delta_B = \Delta_c + \theta_c \times l_{CB}$ . [17]

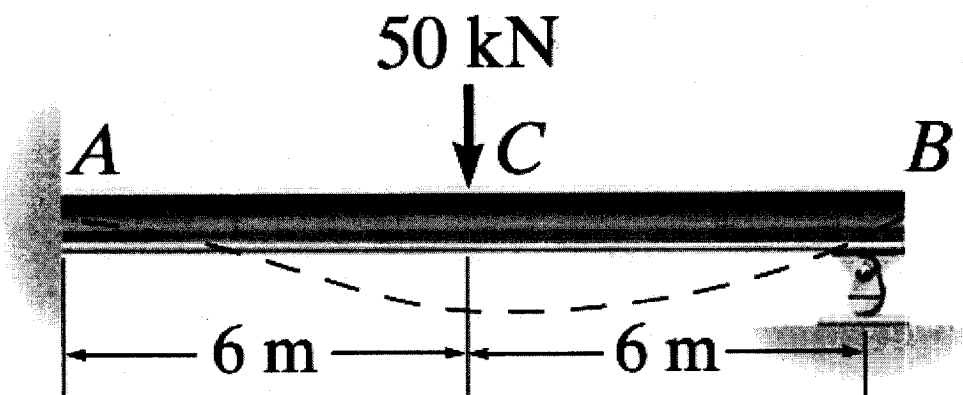

QUESTION 5:

The beam system is shown in the figure below. Using the slope deflection method, determine the moments at A, B, and C and plot the bending moment diagram. The moment of inertia of each span is indicated in the figure. Assume the support at B is a roller and A and C are fixed.  $E = 200$  GPa. [14][6]

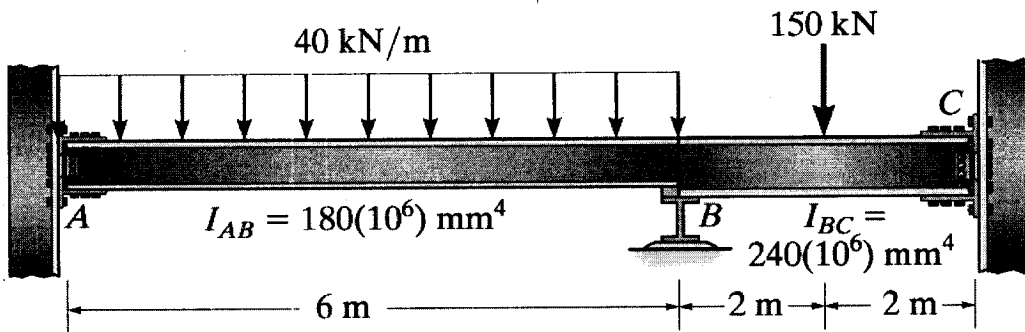

QUESTION 6:

- What is strain energy? [3]
- State Castigliano's second theorem and also state the other name it is called by? [3]
- Using any of the energy methods, find the vertical displacement of point C of the steel beam shown below.  $E_{st} = 200$  GPa and  $I = 1.25 \times 10^{-6} \text{ m}^4$  (hint, 2 Coordinates will be needed). [14]

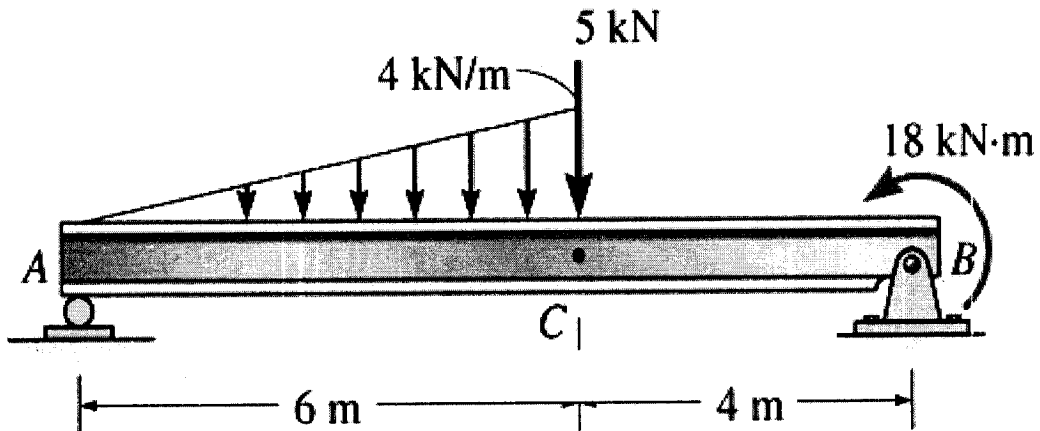

$$2 \frac{1}{3} (180 \times 10^6) \theta_B + 120$$

**SECTION B (Answer 3 questions only)**

**QUESTION 3:**

For the beam system below, draw the influence line for the following:

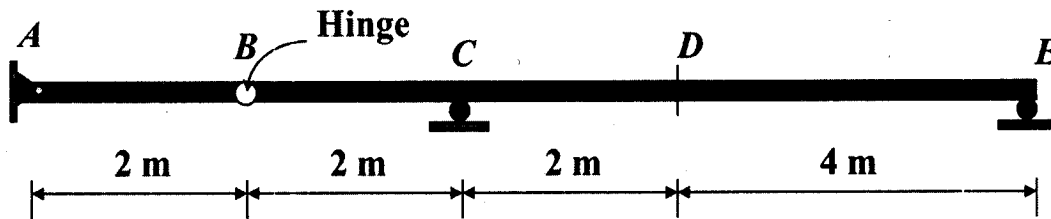

- The reaction at A and E. [5]
- The shear at D. [4]
- The moment at D. [4]
- The maximum moment that can be developed at point D on the beam as a result of: [7]
  - a single concentrate live load of 8550 N
  - a uniform live load of 2750 N/m
  - a beam weight (dead load) of 1220 N/m

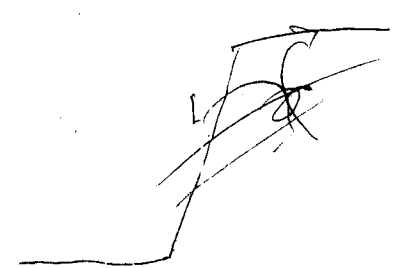

**QUESTION 4:**

The truss below is loaded at the bottom cord.

- Draw the influence line for the force in member BC and member CH. [6] [6]
- For member BC, determine the maximum force that can develop due to a live load of 18KN. [5]

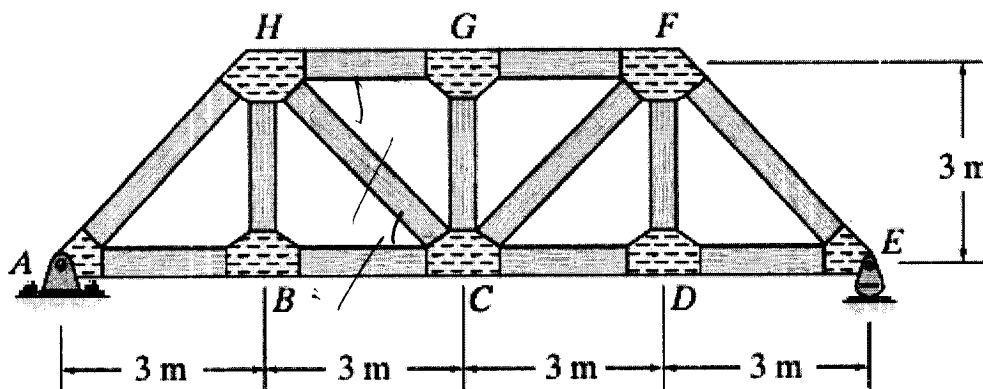

- What is/are the major difference/s between influence lines and bending moment diagrams? [3]

**SECTION A (Compulsory)**

**QUESTION 1:**

- a. The beams shown are used to support a 50 mm thick plywood floor of a residential dwelling. If the dead weight of plywood is  $5.7 \text{ KN/m}^3$  and the live load is  $1.92 \text{ KN/m}^2$ , sketch and label the loading that acts along member BG.  $a = 2.7 \text{ m}$  and  $b = 3.5 \text{ m}$  [8]

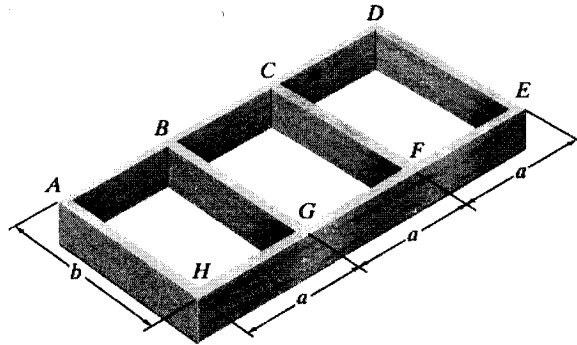

- b. Determine the absolute maximum moment in the beam bridge due to the loading of the truck as shown. [12]

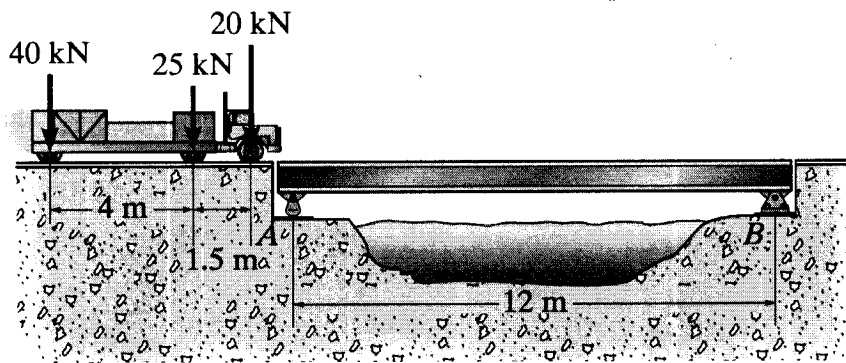

**QUESTION 2**

- a. Define what 'Carry over factor' is in Moment Distribution method? [4]  
 b. Using the moment distribution method, determine the moments at A, B, and C, then draw the moment diagram. EI is constant. (Perform 3 full iterations and then give the answers) [16]

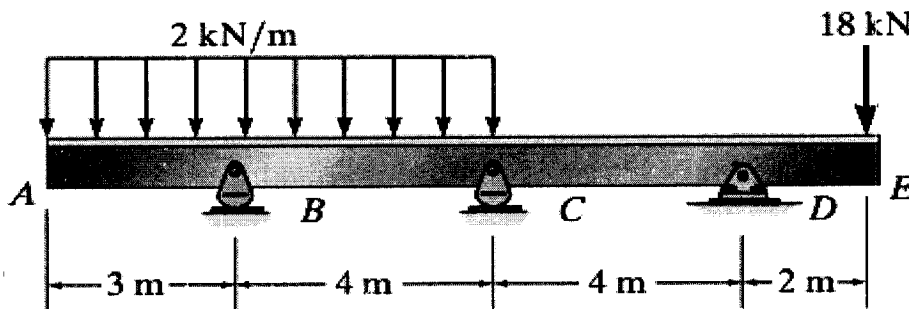

**THE UNIVERSITY OF ZAMBIA**  
**SCHOOL OF ENGINEERING**  
**DEPARTMENT OF CIVIL AND ENVIRONMENTAL ENGINEERING**  
**2021 ACADEMIC YEAR**  
**FINAL EXAMINATIONS**  
**CEE 3311 – FLUID MECHANICS**

**INSTRUCTIONS**

1. Attempt any FIVE questions.
2. All questions carry equal marks (20%). Marks for sub-questions are indicated at the end of each sub-question.
3. If you fail to answer part of a question, assume a value and use it in the subsequent calculations.
4. Make sure the computer number is clearly indicated on all the booklets together with the questions attempted.

**TIME: THREE (3) HOURS**

**CLOSED BOOK EXAM**

**Question 1**

- a) Mention the undesirable effect (s) of cavitation. **(2 marks)**
- b) What is flow work? **(2 marks)**
- c) Mention the two components of drag force on a submerged body. **(2 marks)**
- d) Using the specific energy diagram (Figure 1), indicate the head loss due to a hydraulic jump. **(4 marks)**

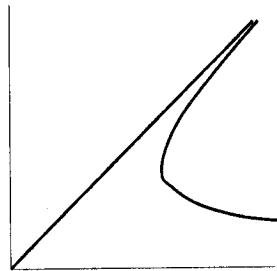
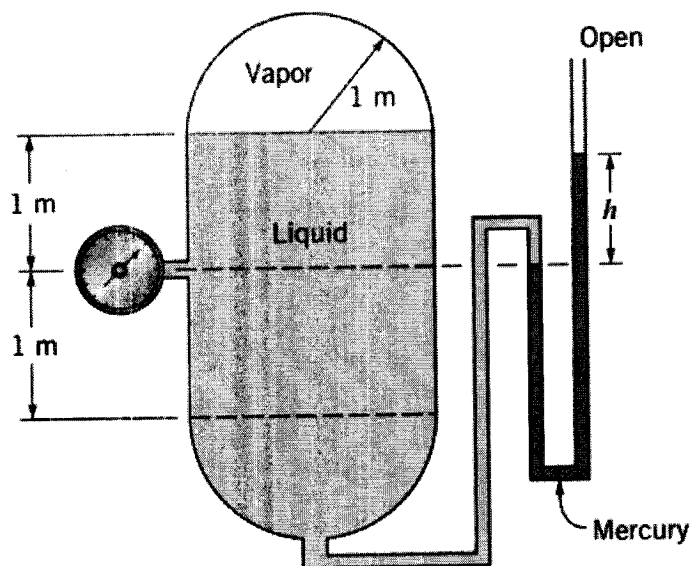

**Figure 1**

- e) A rectangular pontoon has a width of 5m, length of 12m and a draught of 3m in fresh water. Calculate
  - i. weight of pontoon **(2 marks)**
  - ii. its draught in seawater of density  $1100 \text{ kg/m}^3$  **(3 marks)**
  - iii. the load that can be supported by the pontoon in fresh water if the maximum draught permissible is 3.3m. **(5 marks)**

**Question 2**

- a) Briefly explain the behavior of a fluid when subjected to shear stress. (2 marks)
- b) What is the difference (s) between the system and control volume approaches? (3 marks)
- c) Using the equations below, prove that the streamlines and equipotential lines are everywhere perpendicular to each other.  
 $d\phi = -vdx + udy$   
 $d\phi = -udx - vdy$  (5 marks)
- d) Give the definition of uniform flow. (2 marks)
- e) The cylindrical tank with hemispherical ends shown in the figure below contains a volatile liquid and its vapour. The liquid density is  $880 \text{ kg/m}^3$ , and its vapour density is negligible. The pressure in the vapour is  $122 \text{ kPa (abs)}$ , the atmospheric pressure  $110 \text{ kPa (abs)}$  and density of mercury  $13,600 \text{ kg/m}^3$ . Determine
- the gauge pressure reading on the pressure gauge (4 marks)
  - the height  $h$  of the mercury manometer. (4 marks)



**Figure 2**

### Question 3

A plane area of 1m x 1m acts as a window on a submersible in Lake Kariba as shown in Figure 3. If it is on a 40° angle with the horizontal, what force applied at the bottom edge is needed to just open the window, if it is hinged at the top edge when the top edge is 12m below the water surface? The pressure inside the submersible is assumed to be atmospheric. **(20 marks)**

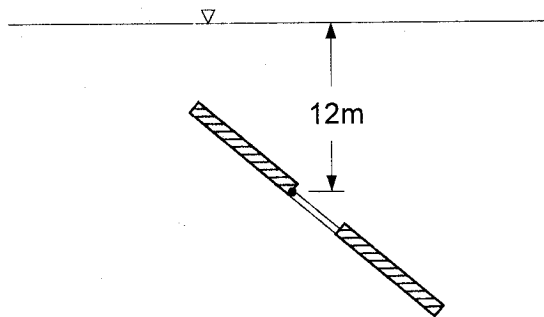

Figure 3

### Question 4

- Distinguish between Lagrangian and Eulerian description of motion. **(4 marks)**
- Briefly explain how the completely turbulent regime is identified in the Moody diagram. **(3 marks)**
- What is fluid mechanics? **(2 marks)**
- Give the Principle of Archimedes **(2 marks)**
- Distinguish between established and unestablished flow in pipes. **(4 marks)**
- A rectangular sign, 10m x 2m, is attached to the top of a 20m-high pole that is 30cm in diameter. The density of air is 1.2kg/m<sup>3</sup>. Compute the maximum force acting on the sign. **(5 marks)**

### Question 5

- What is the use of the momentum equation? **(2 marks)**
- Give areas where the pitot tube is widely used. **(2 marks)**
- Determine whether this flow is rotational or irrotational:  $u = 0, v = 3xy$ . **(3 marks)**

- d) The flow in any pipe network, however complicated, must satisfy 3 equations. Give them. (3 marks)
- e) A rectangular channel 9m wide carries  $8.6\text{m}^3/\text{s}$  when flowing 1m deep. (5 marks)
- i. What is the specific energy? (5 marks)
  - ii. Is the flow subcritical or supercritical? (5 marks)

**Question 6**

- a) The expression  $p - p_1 = -\gamma(z - z_1)$  is generally applicable to liquids, since they are only slightly compressible. Give one example where compressibility of the liquid has to be considered. (2 marks)
- b) What is a hydraulic jump? (2 marks)
- c) Draw and label the energy and hydraulic grade lines and the velocity head for Figure 4. (4 marks)

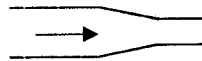

**Figure 4**

- d) Draw a free body diagram of a falling sphere and indicate the forces involved. (2 marks)
- e) The 60mm diameter siphon is drawing oil (specific gravity = 0.85) from the oil reservoir as shown in the figure below. The head loss from point 1 to point 2 is 1.6m and from point 2 to point 3 is 2.5m. Calculate the (5 marks)
- i. Discharge of oil from the siphon (5 marks)
  - ii. The oil pressure at point 2 (5 marks)

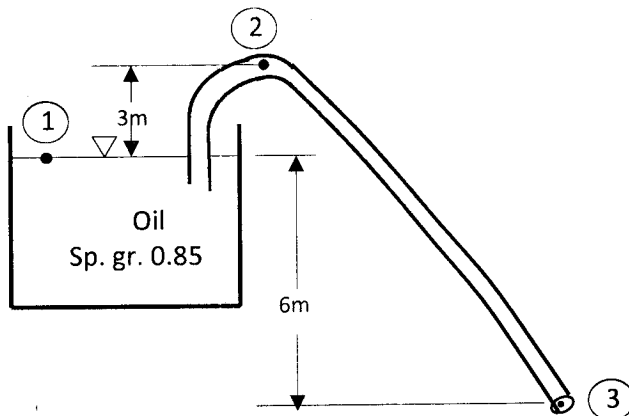

**Figure 5**

### Question 7

Water flows through a horizontal pipe bend and exits into the atmosphere. The bend reduces diameter from 10cm to 5cm. The flow rate is  $0.02\text{m}^3/\text{s}$ . Calculate the force in each of the rods holding the pipe bend in position. Neglect body forces and viscous effects. (20 marks)

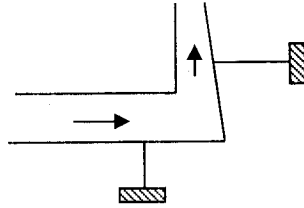

Figure 6

### Question 8

- a) What are streamlines useful indicators of? (2 marks)
- b) Although the Darcy Weisbach Equation is for turbulent flow, it can still be used for laminar flow. Briefly explain. (4 marks)
- c) Oil flows through 3 pipes connected in parallel between points X and Y. Write an expression for the head loss between points X and Y which includes the individual head losses in each pipe. (2 marks)
- d) Briefly describe the flow after the boundary layer separates from the flow. (3 marks)
- e) Points C and D, at the same elevation, are 160m apart in a 200-mm pipe and are connected to a differential gauge by means of small tubing. When the flow of water is  $0.18\text{m}^3/\text{s}$ , the deflection of the mercury in the gauge is 1.96m. Determine the friction factor. (9 marks)

---

END OF EXAMINATION

### USEFUL HINTS

$$Re = \frac{vD}{\nu}$$

$$F_p = C_p \rho \frac{V^2}{2} A$$

$$\text{volume of sphere} = \frac{\pi D^3}{6}$$

$$F \propto \frac{AU}{Y}$$

$$F = 3\pi\mu VD$$

$$\frac{dN_{\text{sys}}}{dt} = \frac{d}{dt} \int_{\text{CV}} \eta \rho dV + \int_{\text{CS}} \eta \rho (\vec{v} \cdot d\vec{A})$$





$$\bar{y} = \frac{1}{A} \int_A y dA$$

$$I_x = \int_A y^2 dA$$

$$I_x = \bar{I} + A\bar{y}^2$$

$$\tau_0 = C_f \rho \frac{v_0^2}{2} = \frac{f}{4} \rho \frac{v^2}{2}$$

Table 1: Drag coefficients for various blunt objects

Object	L/w	Re	C <sub>D</sub>
Square cylinder 	∞	> 10 <sup>4</sup>	2.0
Rectangular plates 	∞	> 10 <sup>3</sup>	2.0
	20	> 10 <sup>3</sup>	1.5
	5	> 10 <sup>3</sup>	1.2
	1	> 10 <sup>3</sup>	1.1
Circular cylinder 	0	> 10 <sup>3</sup>	1.10
	4	> 10 <sup>3</sup>	0.90
	7	> 10 <sup>3</sup>	1.0
	2.0	> 10 <sup>4</sup>	2.0
Equilateral cylinders 	1	> 10 <sup>4</sup>	1.4
	1	> 10 <sup>4</sup>	1.4
Cone 		> 10 <sup>4</sup>	0.8
Parachute		> 10 <sup>7</sup>	1.4
Automobile			
1920	—	> 10 <sup>5</sup>	0.8
Modern	—	> 10 <sup>5</sup>	0.30
Van	—	> 10 <sup>6</sup>	0.42
Bicycle, upright rider			1.1
Semitruck			0.96
Semitruck with streamlined deflector			0.76

THE UNIVERSITY OF ZAMBIA



SCHOOL OF ENGINEERING

DEPARTMENT OF CIVIL & ENVIRONMENTAL ENGINEERING

CEE 3711: SOIL SCIENCE & HYDROLOGY

**FINAL EXAM**

NOVEMBER, 2021

**CLOSED BOOK EXAMINATION**

**TIME ALLOWED: 3 HOURS**

**INSTRUCTIONS TO CANDIDATES**

1. CANDIDATES MUST ENSURE THAT THEIR COMPUTER NUMBERS ARE CORRECTLY WRITTEN ON EACH ANSWER SHEET
2. CANDIDATES MUST ANSWER ANY TWO QUESTIONS FROM SECTION A AND ANY THREE QUESTIONS FROM SECTION B.
3. ALL QUESTIONS CARRY EQUAL MARKS (20%).

## SECTION A

### Question 1

- (a) Illustrate the hydrological cycle
- (b) Lake Kariba has an average surface area of 5 580 km<sup>2</sup> and had a surface elevation of 485.000 m above datum at the beginning of January, 2021. In that month the lake received an average inflow of 6 m<sup>3</sup>/s from surface runoff sources. In the same period the outflow from the lake had an average value of 6.5 m<sup>3</sup>/s. Further, in that month, the lake received a rainfall of 145 mm and the evaporation from the surface was estimated as 6.1 cm. Assume that there is no contribution to or from the groundwater storage. Calculate the change in storage volume of the lake.

[8+ 12 Marks]

### Question 2

The following table shows rainfall amounts at three adjacent stations A, B, C and D.

Rain Gauge Station	Area (km)	Annual Precipitation (mm)	Rainfall for Month of April (mm)
A	20	654	60
B	23	756	67
C	25	674	75
D	27	755	???

- (a) Determine the average annual precipitation using the Thiessen Polygon Method
- (b) Rain gauge D was not operational in the month of April, estimate the amount of rainfall for this gauge using the Arithmetic Mean method for the month it was not operational

[10+10 Marks]

### Question 3

- (a) Describe the water balance/budget equation
- (b) Explain the difference between evaporation, evapotranspiration and transpiration
- (c) Describe FOUR key factors that affect the rate of evaporation

[6+6+8 Marks]

## USEFUL DATA

$$P_x = \frac{N_x}{M} \left[ \frac{P_1}{N_1} + \frac{P_2}{N_2} + \dots + \frac{P_m}{N_m} \right]$$

$$\bar{P} = \frac{P_1 + P_2 + \dots + P_i + \dots + P_n}{N} = \frac{1}{N} \sum_{i=1}^N P_i$$

$$\sum_1^n P_i \frac{A}{A}$$

$$\rho = \frac{M}{V}$$

$$\rho_d = \rho / (1 + w)$$

## SECTION B

You are a novice materials engineer for Njaluka Consult on a project that involves the upgrade of selected roads in Kafue District to bituminous standards. During your field investigations you identified some of the road sections characteristic of clayey materials. The following questions are based on this scenario.

### Question 4

- (a) Recommend the most suitable binder for these road sections and justify your proposal.
- (b) Write the equation that relates void ratio to specific gravity and detail the variables.

[15+5 Marks]

### Question 5

- (a) Detail how you would determine percent compaction from field compaction testing. Write the relevant equation and detail the variables.
- (b) You are given a soil sample that has 20% gravel, 30% sand, and 50% silt/clay size particles (i.e., particles passing the No. 200 sieve). The plastic limit is 10%, the liquid limit 60%. What would be the first letter of the USCS symbol for this soil? Justify your answer.

[15+5 Marks]

### Question 6

- (a) Describe the importance of shrink swell potential and bulk density for any soil material imported to this site
- (b) You are given the following results of an ASTM D4318 (i.e., Atterberg Limits) soils test: plasticity index = 40, plastic limit = 10. Is this a low or high plasticity fine grained soil?

[15+5 Marks]

### Question 7

- (a) Describe the plastic limit of a soil in your own words. What does "plastic" mean?
- (b) Describe the plasticity of the clayey materials identified during your road investigations
- (c) What is the significance of soil compaction during road construction?
- (d) Describe the effects that decreased compaction effort has on maximum dry density and optimum moisture content.

[5+5+5+5 Marks]

Major Divisions		Group Symbols	Typical Names	Laboratory Classification Criteria		
Coarse-grained soils (More than half of material is larger than No. 200 sieve size)	Gravels (More than half of coarse fraction is larger than No. 4 sieve size)	GW	Well-graded gravels, gravel-sand mixtures, little or no fines	$C_u = \frac{D_{60}}{D_{10}}$ greater than 4; $C_c = \frac{(D_{30})^2}{D_{10} \times D_{60}}$ between 1 and 3 Not meeting all gradation requirements for GW		
		GP	Poorly graded gravels, gravel-sand mixtures, little or no fines			
		GM <sup>a</sup>	d	Silty gravels, gravel-sand-silt mixtures	Atterberg limits below "A" line or P.I. less than 4 Above "A" line with P.I. between 4 and 7 are <i>borderline</i> cases requiring use of dual symbols	
			u	Clayey gravels, gravel-sand-clay mixtures		
	Sands (More than half of coarse fraction is smaller than No. 4 sieve size)	Clean sands (Little or no fines)	SW	Well-graded sands, gravelly sands, little or no fines	$C_u = \frac{D_{60}}{D_{10}}$ greater than 6; $C_c = \frac{(D_{30})^2}{D_{10} \times D_{60}}$ between 1 and 3 Not meeting all gradation requirements for SW	
			SP	Poorly graded sands, gravelly sands, little or no fines		
		Sands with fines (Appreciable amount of fines)	SM <sup>a</sup>	d	Silty sands, sand-silt mixtures	Atterberg limits above "A" line or P.I. less than 4 Limits plotting in hatched zone with P.I. between 4 and 7 are <i>borderline</i> cases requiring use of dual symbols
			u	Clayey sands, sand-clay mixtures		
		Fine-grained soils (More than half material is smaller than No. 200 sieve)	Silt and clays (Liquid limit less than 50)	ML	Inorganic silts and very fine sands, rock flour, silty or clayey fine sands, or clayey silts with slight plasticity	
				CL	Inorganic clays of low to medium plasticity, gravelly clays, sandy clays, silty clays, lean clays	
OL	Organic silts and organic silty clays of low plasticity					
Silt and clays (Liquid limit greater than 50)	MH		Inorganic silts, micaceous or diatomaceous fine sandy or silty soils, elastic silts			
	CH		Inorganic clays of high plasticity, fat clays			
	OH		Organic clays of medium to high plasticity, organic silts			
Highly organic soils	Pt		Peat and other highly organic soils			

Determine percentages of sand and gravel from grain-size curve. Depending on percentage of fines (fraction smaller than No. 200 sieve size), coarse-grained soils are classified as follows:  
 Less than 5 per cent  
 More than 12 per cent  
 5 to 12 per cent

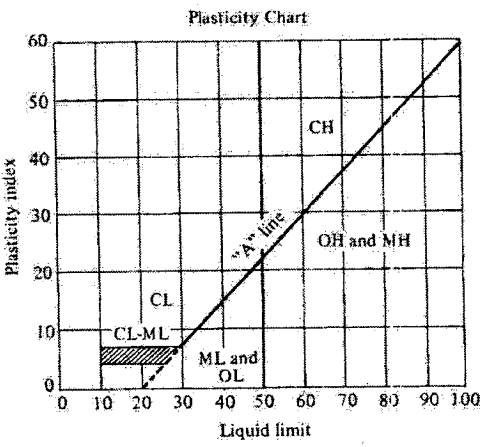

<sup>a</sup> Division of GM and SM groups into subdivisions of d and u are for roads and airfields only. Subdivision is based on Atterberg limits; suffix d used when L.L. is 28 or less and the P.I. is 6 or less; the suffix u used when L.L. is greater than 28.  
<sup>b</sup> Borderline classifications, used for soils possessing characteristics of two groups, are designated by combinations of group symbols. For example: GW-GC, well-graded gravel-sand mixture with clay binder.

Table 8.1 AASHTO soil classification system

General classification	Granular materials (35% or less passing 0.075 mm)		Silt-clay materials (more than 35% passing 0.075 mm)				
Group classification	A-1	A-3	A-2	A-4	A-5	A-6	A-7
	A-1-a	A-1-b	A-2-4	A-2-5	A-2-6	A-2-7	A-7-5, A-7-6
Sieve analysis, percent passing							
2.00 mm (No. 10)	50 max.	—	—	—	—	—	—
0.425 mm (No. 40)	30 max.	51 min.	—	—	—	—	—
0.075 mm (No. 200)	15 max.	25 max.	35 max.	35 max.	35 max.	35 max.	36 min. 36 min. 36 min.
Characteristics of fraction passing 0.425 mm (No. 40)							
Liquid limit	—	—	40 max.	41 min.	40 max.	41 min.	40 max. 41 min.
Plasticity index	6 max.	N.P.	10 max.	10 max.	11 min.	11 min.	10 max. 11 min. 11 min. <sup>a</sup>
Usual types of significant constituent materials	Stone fragments, gravel and sand	Fine sand	Silty or clayey gravel and sand	Silty soils	Silty soils	Clayey soils	Clayey soils
General ratings as subgrade sand	Excellent to Good						Fair to poor

Source: AASHTO (2002).

Note

<sup>a</sup> Plasticity index of A-7-5 subgroup is equal to or less than LL minus 30. Plasticity index of A-7-6 subgroup is greater than LL minus 30.

THE UNIVERSITY OF ZAMBIA

SCHOOL OF ENGINEERING

CIVIL AND ENVIRONMENTAL ENGINEERING DEPARTMENT

2021 ACADEMIC YEAR FINAL EXAMINATION

CEE 4211 DESIGN IN UNREINFORCED MASONRY

TIME: <sup>3</sup> TWO HOURS

INSTRUCTIONS TO CANDIDATE

- (a) Candidates must ensure that their ID numbers are clearly written on each answer booklet used and that the number of answered questions is entered in the space provided on the front of the booklet.
- (b) Answer ALL questions.
- (c) Mathematical gadgets and drawing instruments are allowed.

MAXIMUM SUM OF MARKS: 100

(OPEN BOOK)

QUESTION ONE

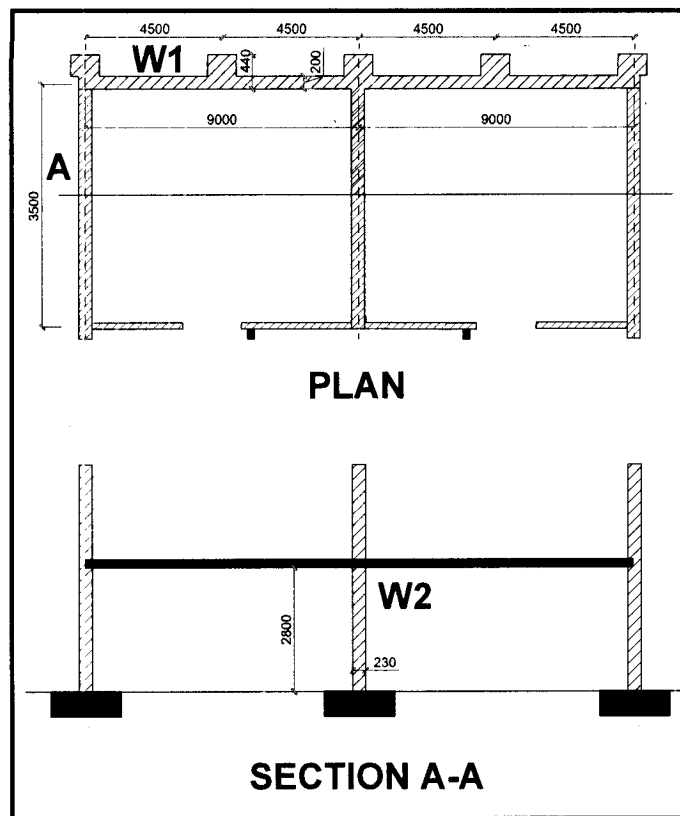

Wall W1 shown above is constructed from concrete block having a compressive strength of  $12\text{N/mm}^2$  laid in 1:1/2:4 mortar. Calculate the ultimate load-bearing capacity of the wall assuming the partial safety factor for materials is 3.5 and the resistance to lateral loading is simple. (25 marks)

### QUESTION TWO

Design wall W2 in Question 1 using mortar designation (II) and standard common bricks. Assume the masonry conform to Category I and the control category is normal. The imposed load is  $1.5\text{kN/m}^2$ , the first floor height is  $2.5\text{m}$ , the brick and the concrete densities are  $55\text{kg/m}^3$  and  $2400\text{kg/m}^3$  respectively. The slab thickness is  $120\text{mm}$ . (25 marks)

### QUESTION THREE

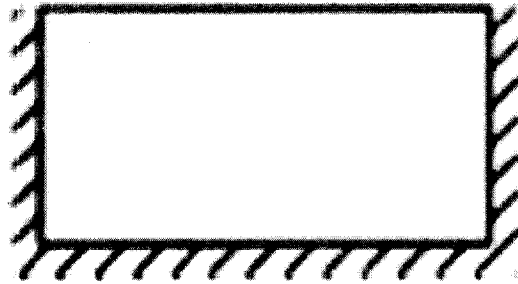

The panel  $3\text{m} \times 4\text{m}$ , shown above is constructed in clay bricks having a water absorption greater than  $12\%$  and mortar designation (II). The clay bricks are Category II and the execution control is Class 1. Calculate the characteristic wind pressure, the wall can withstand assuming the wall is simply supported on three edges as shown, use EC6. (25 marks)

### QUESTION FOUR

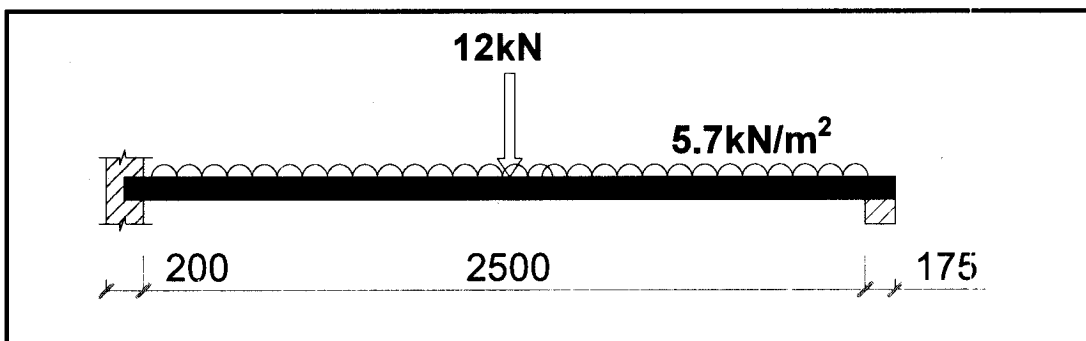

The Figure above shows a timber beam with the given loads. Determine a suitable section for the beam using timber strength class C18 under Class 1 service. Assume that the ends of the beams are held in position and the compression edge is held in line (BS 5268). (25 marks)

**THE UNIVERSITY OF ZAMBIA  
SCHOOL OF ENGINEERING  
DEPARTMENT OF CIVIL AND ENVIRONMENTAL ENGINEERING  
2021 ACADEMIC YEAR FIRST HALF  
FINAL EXAMINATIONS  
CEE 4311 – HYDROLOGY**

**INSTRUCTIONS**

Attempt Five Questions.

All questions carry equal marks (20%). Marks for sub-questions are indicated at the end of each question.

Make sure the computer number is clearly indicated on all the booklets together with the questions attempted

**TIME: THREE (3) HOURS**

**CLOSED BOOK EXAM**

**QUESTION ONE**

- a) What are the benefits of the hydrological science in practical life?
- b) Briefly explain the importance of each of the hydrological cycle components listed below:
- (i) Surface runoff
  - (ii) Groundwater flow
  - (iii) Evaporation
- (b) A small catchment of area 150ha received a rainfall of 10.5cm in 90 minutes due to a storm. At the outlet of the catchment, the stream draining the catchment was dry before the storm and experienced a runoff lasting 10hrs with an average discharge value of  $2.0\text{m}^3/\text{s}$ . The stream was again dry after the runoff event.
- (i.) What is the amount of water which was not available to runoff due to combined effect of infiltration, evaporation and transpiration?
  - (ii.) What is the ratio of runoff to precipitation?

***[5+5+10= 20 Marks]***

## **QUESTION TWO**

- (a) Give three methods to estimate areal precipitation and comment on the accuracy.
- (b) Outline sources of error when recording readings and record-keeping by precipitation gauge.
- (c) The precipitation on a catchment in Lukulu of area 95 km<sup>2</sup> is sampled in Table (1). Determine the precipitation recorded by station number (7) if the mean precipitation, as computed by Thiessen method, amounts to 98mm.

**Table: 1**

Rain gauge	Recorded rainfall (mm)	Thiessen polygon area (km <sup>2</sup> )
1	84	4.0
2	90	4.0
3	120	10.0
4	86	5.1
5	87	15.1
6	76	30.6
7	X	6.2
8	131	20.0

**[5+5+10= 20 Marks]**

## **QUESTION THREE**

- (a) You are working as a hydrologist in a city with high water demand. List three measures that may be used to help minimise evaporation.
- (b) List the various data needed to use Penman equation for estimating the potential evapotranspiration from a given area.
- (c) What are the main differences between evaporation and transpiration?
- (d) A class A pan was set up adjacent to a lake. The depth of water in the pan at the beginning of a certain week was 195mm. In that week there was a rainfall of 45mm and 15mm of water was removed from the pan to keep the water level within the specified depth range. If the depth of the water in the pan at the end of the week was 190 mm,
  - (i) Calculate the pan evaporation.
  - (ii) Using a suitable pan coefficient estimate the lake evaporation in that week.

**[4+4+4+ 8= 20 Marks]**

#### **QUESTION FOUR**

- (a) Explain the following hydrological terms
- (i) catchment
  - (ii) watershed
  - (iii) drainage basin
  - (iv) divide
- (b) Distinguish between Infiltration capacity and infiltration rate
- (c) Describe the commonly used procedures for determining the infiltration characteristics of a given plot of land. Explain clearly the relative advantages and disadvantages of the enumerated method.
- (d) The infiltration capacity of a catchment is represented by Horton equation as shown below where  $F_p$  is in cm/h and  $t$  is in hours. Assuming the infiltration takes place at capacity rates during a storm of 4 hours' duration, estimate the average rate of infiltration for the duration of the storm.

$$f_p = 0.5 + 1.2e^{-0.5t}$$

*[4+4+4+ 8= 20 Marks]*

#### **QUESTION FIVE**

- (a) Explain how a weir may be used to measure the flow rate in a stream.
- (b) What factors should be considered in selecting a site for a stream gauging station?
- (c) The Zambezi River gauging in Livingstone gives  $Q = 3020 \text{ m}^3 / \text{s}$ . The gauging took 2 hours during which the gauge rose from 50.40 to 50.52 m. The slope of the river surface at the gauging site at the time was 5 cm in 400 m, and the cross-section of the river at the site was 300 m wide by 3 m deep.
- (i) What adjusted value of discharge would you use?
  - (ii) What is Manning's  $n$  for this river at this time?

*[6+4+10 =20 Marks]*

#### **QUESTION SIX**

- (a) What is flood frequency analysis?
- (b) Provide brief definitions for the following:
- (i) Return period

(ii) Exceedance probability

(c) Consider the annual maximum discharge  $Q$ , (in cumecs), of a river for 45 years. Using the data given in Table 6 (c)

(i) What is the probability that the annual maximum discharge in the river will exceed or equal 1500 cumecs for the data given in Table 6 (c)?

(ii) Obtain the probability that the annual maximum discharge in the river will equal or exceed 1500 cumecs at least once in the next five years

**Table 6 (c)**

Year	Q	Year	Q	Year	Q	Year	Q
1950	804	1961	507	1972	1651	1983	1254
1951	1090	1962	1303	1973	716	1984	430
1952	1580	1963	197	1974	286	1985	260
1953	487	1964	583	1975	671	1986	276
1954	719	1965	377	1976	3069	1987	1657
1955	140	1966	348	1977	306	1988	937
1956	1583	1967	804	1978	116	1989	714
1957	1642	1968	328	1979	162	1990	855
1958	1586	1969	245	1980	425	1991	399
1959	218	1970	140	1981	1982	1992	1543
1960	623	1971	49	1982	277	1993	360
						1994	348

[2+4+7+7= 20 Marks]

**QUESTION SEVEN**

(a) In your opinion, what is the most significant source of groundwater pollution in Lusaka?

(b) What are the factors affecting groundwater flow within a basin?

(c) The static level of water table in an unconfined aquifer was 30 m above the underlying impermeable stratum. A 150 mm diameter well, penetrating the aquifer to its full depth, was pumped at the rate of 20 liters per second. After several weeks of pumping, the drawdown in observation wells 20 m and 50 m from the well were 3.5 m and 2 m respectively, and the

observed drawdowns were increasing very slowly. Assuming equilibrium conditions, estimate the

(i) hydraulic conductivity

(ii) transmissivity of the aquifer

*[5+ 5+10= 20 Marks]*

***END OF EXAMINATION***

## USEFUL EQUATIONS

$$f(t) = f_c + (f_0 - f_c)e^{-kt}$$

$$P_x = \frac{N_x}{M} \left[ \frac{P_1}{N_1} + \frac{P_2}{N_2} + \dots + \frac{P_m}{N_m} \right]$$

$$\bar{P} = \frac{P_1 + P_2 + \dots + P_i + \dots + P_n}{N} = \frac{1}{N} \sum_{i=1}^N P_i$$

$$E = P + I \pm U - O \pm S$$

$$E_a = 0.35 (e_o - e_a)(0.5 + 0.54 u_2)$$

$$Q = KA \frac{\partial h}{\partial x}$$

Depth < 0.6m       $\bar{V} = V_{0.6d}$ ; 0.6 water depth from the water surface

0.6m ≤ Depth ≤ 2m       $\bar{V} = \frac{V_{0.2d} + V_{0.8d}}{2}$

Depth ≥ 2m       $\bar{V} = \frac{V_{0.2d} + 2V_{0.6d} + V_{0.8d}}{4}$

$$v = \frac{1}{n} R^{2/3} S^{1/2}$$

$$P = \left(1 - \left(1 - \frac{1}{T}\right)^N\right)$$

---



**THE UNIVERSITY OF ZAMBIA  
SCHOOL OF ENGINEERING  
DEPARTMENT OF CIVIL AND ENVIRONMENTAL ENGINEERING  
2021 ACADEMIC YEAR  
CEE 4412 – ENVIRONMENTAL ENGINEERING I  
UNIVERSITY END OF YEAR EXAMINATIONS**

**TIME: THREE (3) HOURS**

**CLOSED BOOK**

---

---

**INSTRUCTIONS TO CANDIDATES**

- 1. THE PAPER CONTAINS SEVEN (07) QUESTIONS.**
  - 2. ATTEMPT QUESTION ONE, WHICH IS COMPULSORY AND ANY OTHER FOUR QUESTIONS.**
  - 3. THE COMPULSORY QUESTION (QUESTION ONE) CARRIES 28 MARKS WHILST ALL THE OTHER QUESTIONS CARRY 18 MARKS EACH.**
  - 4. ALL SOLUTIONS SHOULD BE CLEARLY NUMBERED.**
  - 5. WHERE INFORMATION IS NOT GIVEN, MAKE AND CLEARLY STATE YOUR ASSUMPTIONS.**
  - 6. MARKS WILL BE LOST FOR UNTIDY AND UNORGANISED PRESENTATION.**
  - 7. A GLOSSARY OF SOME SELECTED EQUATIONS AND INFORMATION IS PRESENTED IN THE ANNEX.**
- 
-

### **QUESTION ONE - COMPULSORY**

- a) List any four functions of an anaerobic pond in a wastewater stabilization pond system.
- b) Explain how the following treatment mechanisms for the removal of microorganisms are achieved in maturation ponds:
- Starvation induced mortality of microorganisms.
  - Predation.
- c) The newly commissioned conventional wastewater treatment plant for Pemba District has the following units in place:
- All the units in the preliminary treatment stage;
  - Four primary sedimentation tanks; and
  - Eight trickling filters.

All these units have been adequately designed. However, analysis of process parameters indicates that the concentration of organic matter in the effluent is still very high despite the units being adequately designed and functioning properly. State one possible reason for this situation and give a solution to this problem.

- d) A newly developed estate generates  $10,000 \text{ m}^3$  of wastewater per day. This wastewater has an average organic matter concentration of  $500 \text{ mg BOD/L}$  and a Faecal Coliform count of  $1,000,000 \text{ CFU/100mL}$ . Given that the minimum and maximum mean ambient monthly temperatures in the area are  $15^\circ\text{C}$  and  $25^\circ\text{C}$  experienced in July and October, respectively;
- Compute the required area of the anaerobic pond for the treatment of this wastewater.
  - What would be the BOD concentration in the effluent from this pond?

[ 4 + 6 + 6 + 12 ]

### **QUESTION TWO**

- a) Explain the purpose of water treatment
- b) A water treatment plant employs four (04) rectangular sedimentation tanks which feed eight (08) circular slow sand filters. Each sedimentation tank has a surface area of  $300 \text{ m}^2$  and an effective depth of  $3.5 \text{ m}$ . Given that the sedimentation tanks are operated at a surface loading rate of  $0.5 \text{ m/h}$ ,
- Compute the daily water production from the treatment plant.
  - If the filters are operated at a surface loading rate of  $2 \text{ m}^3/\text{m}^2 \cdot \text{day}$ , calculate the required diameter of each slow sand filter.
- c) Nkamba District has 5,200 inhabitants. 70 percent of this population resides in medium cost areas where the daily per capita water consumption is 150 liters. The remaining population is in low-cost areas where the per capita water consumption is 100 liters. The district's population grows linearly at an annual growth rate of 2 percent. A wastewater treatment plant has been proposed

for the district with a 20-year design period. Leakages and losses in the system are anticipated at 25 percent.

- i) Compute the average quantity of water that should be treated to meet the needs of the district.
- ii) Given that 80 percent of the water used is generated as wastewater, compute the required volume of an anaerobic pond if it will be designed with a retention time of five (5) days.

[ 3 + 7 + 8 ]

### QUESTION THREE

- a) List the general components of a water supply system.
- b) Iolanda water treatment plant treats water at a rate of  $1.16\text{m}^3/\text{s}$ . Disinfection is through the use of gaseous chlorine. Laboratory results for a chlorine demand test have revealed that the water has a chlorine demand of  $5\text{mg/L}$ . If it is desired to have a residual chlorine of  $4\text{mg/L}$  after treatment, compute how much chlorine should be dosed on a daily basis.
- c) Figure 1 below illustrates results of the Jar Test performed on raw water from the Kaseba Water Treatment Plant in Kafue.

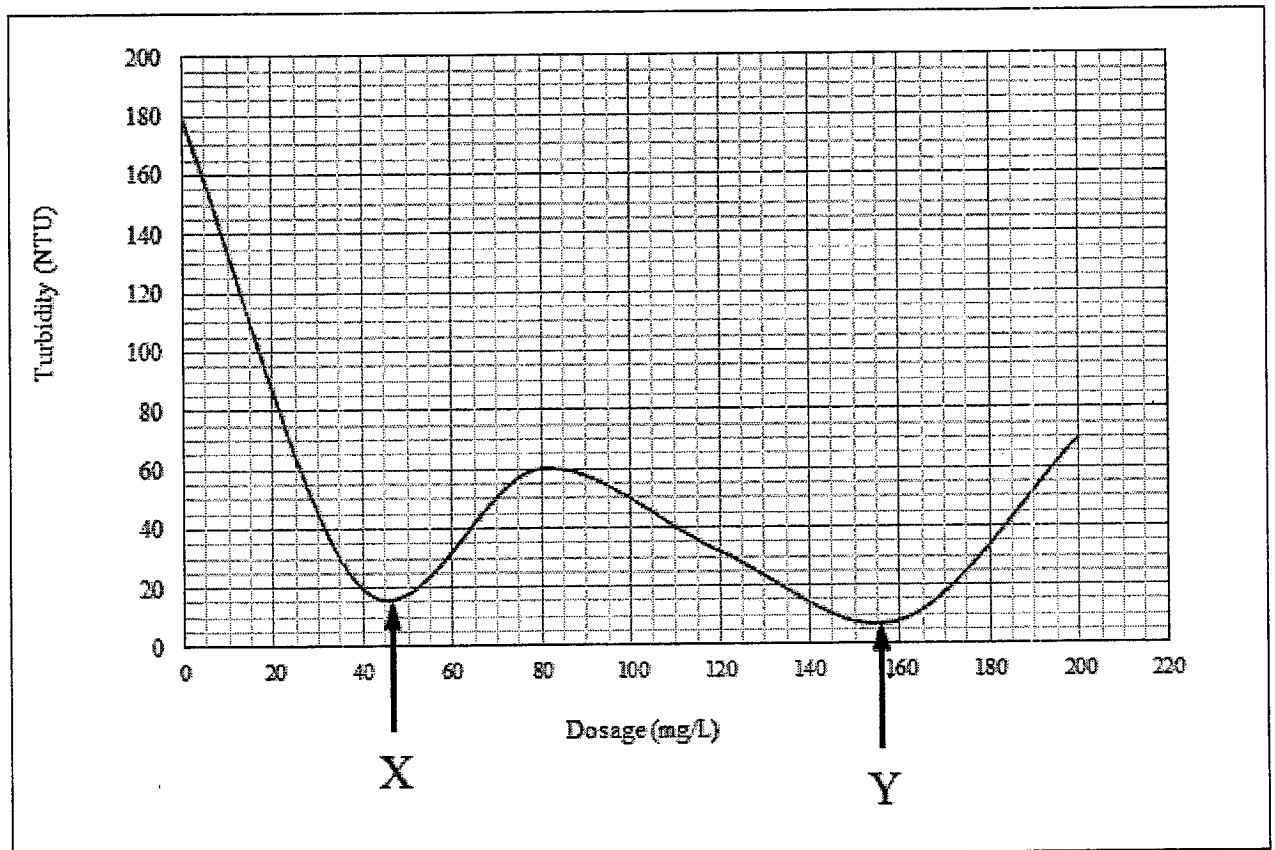

Figure 1: Jar Test results for the Kaseba Water Treatment Plant raw water

It was observed that the engineer in charge of water treatment adopted the dosage at 'X' as the dosage for the plant despite the dosing at point Y giving the best results in terms of turbidity reduction.

- i) Give one reason to justify the engineer's decision.
- ii) If the treatment plant treats water at a rate of 50L/s, compute how much coagulant is required on a daily basis at the adopted dosing rate (i.e., at point X).

[ 3 + 7 + 8 ]

#### QUESTION FOUR

- a) Discuss one impact of a non-functional grit removal system in a wastewater treatment plant.
- b) Give a justification for the requirement to have a maximum of 80 colony forming units on a membrane during the enumeration of faecal and total coliforms in the examination of the microbiological quality of water utilization the membrane filtration method.
- a) A conventional wastewater treatment plant receives wastewater at a rate of  $4.0\text{m}^3/\text{s}$ . The organic matter concentration (BOD) in the wastewater is  $500\text{mg/L}$ . Primary treatment, provided through the use of four circular sedimentation tanks with a diameter of 30m and a depth of 3.5m, removes 20 percent of the organic matter. The settled wastewater is then treated by six (06) trickling filters, each with a radius of 14 m and a depth of 1.5 m;
  - i) Compute the Organic Surface Loading Rate for each of the trickling filters.
  - ii) Compute the Hydraulic Loading Rate for each filter.

[ 4 + 5 + 9 ]

#### QUESTION FIVE

- a) Give and explain two reasons why the primary treatment stage is important in a conventional wastewater treatment plant utilizing trickling filters.
- b) Mr. Tsolidama has just been employed as a Wastewater Treatment Plant Operator in charge of the Bulangililo Wastewater Treatment Plant in Kitwe District. This plant employs anaerobic sludge treatment mechanisms for sludge stabilization. It was observed that, when operating the anaerobic treatment unit, Mr. Tsolidama would allow the sludge to accumulate in the thickening tank and would then load all the sludge to the digesters at 17:00 hrs every day. With this type of operation, it was noticed that the sludge treatment efficiency dropped.
  - i) Explain one possible reason for the observed reduced treatment efficiency.
  - ii) Give one remedial measure you would put in place to address the situation and explain the reason why.
- c) An aeration tank for treatment of wastewater in an activated sludge treatment plant is designed to operate with a solids content of between  $2\text{ kg/m}^3$  to  $8\text{ kg/m}^3$ . In a laboratory analysis of the

Mixed Liquor Suspended Solids (MLSS) collected from this aeration tank, it was found that in a 150 mL sample of the MLSS, the dry solids matter content was 2.5 g.

- i) Explain one problem that you would expect in this treatment plant.
- ii) State and explain the measure(s) you would employ to correct the situation (in case there is a problem).

[ 4 + 6 + 8 ]

#### QUESTION SIX

- a) Give any two factors that would motivate you as a sanitary engineer to advocate for an onsite sanitation system as a means of sanitation service provision in a newly developed district.
- b) For pit latrines that are supposed to be buried at the end of their service life, explain why the burying should be done before they are completely full (i.e., at most, they should be buried when they are only 75 percent full).
- c) A septic tank is designed to service a block of flats in Chalala where the daily average per capita water consumption is 150 liters. From the water supplied, 80 percent of the water ends up as wastewater. The Sludge Accumulation Rate (SAR) is estimated at 40 liters per capita per year.
  - i) Given that the total population accommodated in the flats is 40 people, determine the required volume of the septic tank for the treatment of this wastewater if the retention time at the time of inception will be 4 days.
  - ii) If desludging of this septic tank should be when the solids take up 50 percent of the tank volume, compute how many years it will take before the tank is desludged.

[ 5 + 4 + 9 ]

#### QUESTION SEVEN

- a) Solid Waste Management is defined as a systematic control of the generation, collection, storage, transport, source separation, processing, treatment, recovery, and disposal of solid waste. As a Sanitary Engineer tasked with management of solid waste, explain any two measures you can institute at the point of generation to enhance management of the solid waste.
- b) Briefly discuss one reason why knowing the density of solid waste is an important prerequisite for the effective implementation of a solid waste management system.
- c) Discuss one way in which composition of the solid waste affects the design of measures for a sound solid waste management system.
- d) Discuss any two distinctions between the operations of a sanitary landfill versus a dumpsite.

[ 5+4 + 4 + 5 ]

**END OF EXAMINATION**

**JMT /EXAM/CEE 4412/2021**

---

**ANNEX: GLOSSARY OF EQUATIONS**

i)  $Q_a = dACq$                       ii)  $Q_a = ACq_a$                       iii)  $Q_a = A \sum_{i=1}^n d_i q_i p_i C_i$

iv)  $Q_a = A \sum_{i=1}^n q_a p_i C_i$                       v)  $Q_{i+n} = Q_i * (1 + n * \frac{a}{100})$                       vi)  $Q_{i+n} = Q_i * (1 + \frac{a}{100})^n$

vii)  $Q_d = (Q_a * pf_0) / (1 - L/100)$

viii) *Design volumetric organic loading rates for anaerobic ponds as a function of the monthly average ambient temperature.*

Minimum monthly ambient temperature (°C)	Volumetric organic loading rate $\lambda_v$ (in g BOD <sub>5</sub> /m <sup>3</sup> .d)	BOD <sub>5</sub> removal (%)
< 10	100	40
10 – 20	20T – 100	2T + 20
> 20	300	60

*Where T is the monthly average ambient temperature*

ix) Equation for determination of anaerobic pond area

$$A = \frac{S_i Q}{\lambda_v D}$$

where

- Q = hydraulic loading (m<sup>3</sup>/d)
- S<sub>i</sub> = influent BOD<sub>5</sub> concentration (mg/l)
- $\lambda_v$  = Volumetric organic loading rate (g BOD<sub>5</sub>/m<sup>3</sup>.d)
- D = Average pond depth (m)
- A = Surface area of anaerobic pond (m<sup>2</sup>)

The organic surface loading rate  $\lambda_s$

$$\lambda_s = \frac{LO(g/m^3 * m^3/d)}{A(m^2)} = BOD(g/m^2.d)$$

Where

- L = BOD influent (mg/l)
- Q = Sewage flow (m<sup>3</sup>/day)
- A = Pond area (m<sup>2</sup>)

Also  $\lambda_s = 2T - 12$  ( $\text{g/m}^2 \cdot \text{day}$ ) where T is the mean monthly ambient temperature of the coldest month in  $^{\circ}\text{C}$ .

Equation for the design of maturation ponds

$$\frac{N_e}{N_i} = \frac{1}{\left[1 + K_b \frac{\tau}{n}\right]^n}$$

Where  $N_i$  and  $N_e$  = number of faecal coliforms in the effluent and influent respectively

$\tau$  = hydraulic retention time

$K_b$  = the die off rate coefficient (in  $\text{day}^{-1}$ ) which is temperature dependent and is given

by

$$K_b = 2.6(1.19)^{(T-20)} \quad \text{Where T is temperature in } ^{\circ}\text{C}.$$

**THE UNIVERSITY OF ZAMBIA**  
**SCHOOL OF ENGINEERING**  
**DEPARTMENT OF CIVIL AND ENVIRONMENTAL ENGINEERING**  
**CEE 4612 – HIGHWAY AND TRAFFIC ENGINEERING**

**EXAM REFERENCE MATERIAL**

**INSTRUCTIONS TO CANDIDATES**

1. THIS BOOKLET CONTAINS REFERNCE MATERIAL IN FORM OF FORMULAS, TABLES, GRAPHS, ETC
2. NOT ALL INFORMATION PROVIDED IN THIS BOOKLET IS USEFUL FOR THIS EXAM. THUS, YOU ARE REQUIRED TO READ AND UNDERSTAND EACH QUESTION AND IDENTIFY THE NECESSARY FORMULAS, TABLES, AND/OR GRAPHS TO USE

## Stopping Sight Distance (SSD)

1.

SSD = PR Distance + Braking Distance

$$SSD = 0.278 PV + \frac{v^2}{254(f \pm G)}$$

$P$  = PIEV time (s)

$V$  = design speed (km/h)

$f$  = coefficient of longitudinal friction

$G$  = longitudinal grade (decimal fraction)

(-ve → downhill & +ve → uphill)

2.

$$SSD = 0.278 P V + \frac{v^2}{254 \left( \frac{a}{g} \pm G \right)}$$

## TRAFFIC ENGINEERING STUDIES

Expansion of Traffic Volume	
1	Total Volume for 24 Hrs = Hourly Expansion Factor * Volume of Particular Hour
2	Total Volume for 7 Days = Daily Expansion Factor * Volume of Particular Day
3	Average Daily Traffic = (Total Volume for 7 Days)/7 = (Daily Expansion Factor * Volume of Particular Day)/7
4	Average Annual Daily Traffic = Monthly Expansion Factor * Volume (ADT) of Particular Month

Figure 1: Equations for Expansion of Traffic Volume

## ROAD SAFETY

1. Rate per Million of Entering Vehicles (RMEVs):

$$RMEV = \frac{A \times 1,000,000}{V}$$

where

$RMEV$  = crash rate per million entering vehicles

$A$  = number of crashes, total or by type occurring in a single year at the location

$V$  = average daily traffic (ADT) × 365

This rate is often used as a measure of crash rates at intersections.

## 2. Rate per 100 Million Vehicle Kilometers (Miles) (RMVM):

$$RMVM = \frac{A \times 100,000,000}{VMT}$$

where

$A$  = number of crashes, total or by type at the study location, during a given period

$VMT$  = vehicle miles of travel during the given period

=  $ADT \times (\text{number of days in study period}) \times (\text{length of road})$

This rate is often used as a measure of crash rates on a stretch of highway with similar traffic and geometric characteristics.

## 3. Crash Severity Ratio (CSR):

$$CSR = \frac{w_f \times F + w_i \times I + PDO}{F + I + PDO}$$

Where:

$F$  = Fatal Crashes

$I$  = Injury Crashes

$PDO$  = Property Damage Only

$w_f$  = weight for fatal crashes

$w_i$  = weight for injury crashes

## HIGHWAY LOCATION, GEOMETRICS, & DRAINAGE

### 1. Vertical Curve Staking

#### i. Y-Offset

$$Y = \frac{Ax^2}{200L}$$

#### ii. Curve Elevations

$$Elev = Elev(BVC) \pm \frac{g_1 x}{100} + Y$$

#### iii. Highest or Lowest Point

$$x_{HP \text{ or } LP} = \frac{g_1 L}{A}$$

## 2. K-Values for Vertical Curves

Table 1: Design Controls for Crest Curves

Design speed (km/h)	Stopping sight distance (m)	Metric	
		Rate of vertical curvature, $K^a$	
		Calculated	Design
20	20	0.6	1
30	35	1.9	2
40	50	3.8	4
50	65	6.4	7
60	85	11.0	11
70	105	16.8	17
80	130	25.7	26
90	160	38.9	39
100	185	52.0	52
110	220	73.6	74
120	250	95.0	95
130	285	123.4	124

Table 2: Design Controls for Sag Curves

Design speed (km/h)	Stopping sight distance (m)	Metric	
		Rate of vertical curvature, $K^a$	
		Calculated	Design
20	20	2.1	3
30	35	5.1	6
40	50	8.5	9
50	65	12.2	13
60	85	17.3	18
70	105	22.6	23
80	130	29.4	30
90	160	37.6	38
100	185	44.6	45
110	220	54.4	55
120	250	62.8	63
130	285	72.7	73

## 3. Minimum Horizontal Curve Radius

$$R = \frac{V^2}{127(f_s + e)}$$

– Where:

$R$  = Radius (m)

$V$  = Speed (km/h)

$f_s$  = Coefficient of side friction

$e$  = superelevation rate (decimal fraction)

Table 3: Lateral Friction Values

Design Speed (km/h)	Maximum Lateral Friction for Rural and High Speed Urban Design
40	0.17
50	0.16
60	0.15
70	0.15
80	0.14
90	0.13
100	0.12
110	0.10
120	0.09
130	0.08

4. Horizontal Curve Geometry (Simple Curve)

- $T = R \times \tan\left(\frac{\Delta}{2}\right)$
- Station of PC = Station of PI - T
- $L_c = R \times \Delta \times \frac{\pi}{180}$
- Station of PT = Station of PC +  $L_c$
- Station of PT  $\neq$  Station of PI + T

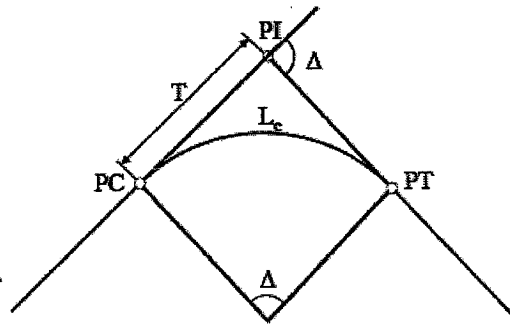

1. Superelevation Runoff

- $L_r = \frac{(w n_1) e_d}{\Delta} (b_w)$ 
  - »  $L_r$  = minimum length of superelevation runoff
  - »  $\Delta$  = maximum relative slope
  - »  $n_1$  = number of lanes rotated = one half of all lanes for rotation around centerline
  - »  $b_w$  = adjustment factor for number of lanes rotated
  - »  $w$  = width of one traffic lane
  - »  $e_d$  = design superelevation rate

Table 4: Maximum Relative Slope between Outer Edge of Pavement and Centreline

Design Speed (km/h)	Relative Slope (%)
40	0.70
50	0.65
60	0.60
70	0.55
80	0.51
90	0.47
100	0.44
110	0.41
120	0.38
130	0.36

Table 5: Lane Adjustment Factors for number of lanes rotated

Number of Lanes Rotated, $n_1$	Adjustment factor, <sup>*</sup> $b_w$	Length Increase Relative to One Lane Rotated, ( $= n_1 b_w$ )
1	1.00	1.0
1.5	0.83	1.25
2	0.75	1.5
2.5	0.70	1.75
3	0.67	2.0
3.5	0.64	2.25

### Tangent Runout

$$- L_t = \frac{e_{NC}}{e_d} L_r$$

- $L_t$  = minimum length of tangent runout
- $e_{NC}$  = normal cross slope rate
- $e_d$  = design superelevation rate
- $L_r$  = minimum length of superelevation runoff

## STRUCTURAL DESIGN OF PAVEMENTS

### 1. ESAL

$$ESAL_i = f_d \times G_{rn} \times AADT_i \times 365 \times N_i \times F_{Ei}$$

where

ESAL<sub>*i*</sub> = equivalent accumulated 18,000-lb (80 kN) single-axle load for the axle category *i*

*f<sub>d</sub>* = design lane factor

*G<sub>rn</sub>* = growth factor for a given growth rate *r* and design period *n*

AADT<sub>*i*</sub> = first year annual average daily traffic for axle category *i*

*N<sub>i</sub>* = number of axles on each vehicle in category *i*

*F<sub>Ei</sub>* = load equivalency factor for axle category *i*

$$G_{rn} = [(1 + r)^n - 1]/r$$

where

$r = \frac{i}{100}$  and is not zero. If annual growth is zero, growth factor = design period

*i* = growth rate

*n* = design life, yrs

## HIGHWAY MATERIALS

$$GI = \overbrace{(F-35)}^{0-40} [0.2 + 0.005 \overbrace{(LL-40)}^{0-20}] + 0.01 \overbrace{(F-15)}^{0-40} \overbrace{(PI-10)}^{0-20}$$

1. - F = percentage passing #200

## 2. ASSHTO CLASSIFICATION OF SOILS AND SOIL AGGREGATE MIXTURES

General Classification	Granular Materials (35% or Less Passing No. 200)						Silt-Clay Materials (More than 35% Passing No. 200)							
Group Classification	A-1		A-2				A-3		A-4				A-7	
Sieve analysis	A-1-a	A-1-b	A-2-1	A-2-2	A-2-3	A-2-4	A-2-5	A-2-6	A-2-7	A-3	A-4	A-5	A-6	A-7-5, A-7-6
Percent passing														
No. 10	-50 max.	-	-	-	-	-	-	-	-	-	-	-	-	-
No. 40	30 max.	50 max.	51 min.	-	-	-	-	-	-	-	-	-	-	-
No. 200	15 max.	25 max.	10 max.	35 max.	35 max.	35 max.	35 max.	35 max.	35 max.	36 min.	36 min.	36 min.	36 min.	36 min.
Characteristics of fraction passing No. 40:														
Liquid limit	-	-	-	-	-	-	-	-	-	-	-	-	-	-
Plasticity index	6 max.	-	N.P.	40 max.	41 min.	40 max.	41 min.	40 max.	41 min.	40 max.	41 min.	40 max.	41 min.	41 min.
Usual types of significant constituent materials	Stone fragments, gravel and sand		Fine sand				Silty or clayey gravel and sand				Silty soils		Clayey soils	
General rating as subgrade	Excellent to good													Fair to poor

\* Plasticity index of A-7-5 subgroup = LL - 30. Plasticity index of A-7-6 subgroup = LL - 30.  
 SOURCE: Adapted from *Standard Specifications for Transportation Materials and Methods of Sampling and Testing*, 27th ed., Washington, D.C., The American Association of State Highway and Transportation Officials, copyright 2007. Used with permission.

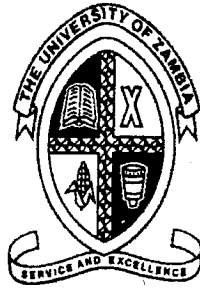

# THE UNIVERSITY OF ZAMBIA

## SCHOOL OF ENGINEERING

### DEPARTMENT OF ELECTRICAL AND ELECTRONIC ENGINEERING

#### UNIVERSITY EXAMINATIONS

FINAL EXAM – November / December 2021

## **EEE 3112**

### **ELECTRICAL ENGINEERING PRACTICE**

---

<b>TIME</b>	: Three (3) hours
<b>INSTRUCTIONS</b>	: Answer any Four Questions in section A and Any One (1) question (compulsory) in section B. .
<b>ADDITIONAL INFORMATION</b>	: Submit SECTION A and SECTION B in Separate Answer Booklets.

---



## QUESTION TWO

- a) State and briefly describe the four types of diagrams commonly used in electrical and electronics drawing. **[4 Marks]**
- b) Design a solar based multipurpose charger circuit diagram. A 12 V, 5W solar panel is used as the source of current. The circuit diagram should be able to charge a 3.7V Mobile phone batteries, 6V NiCd batteries, and 12V lead acid batteries. The following components should be used in the circuit diagram
- IC1 7812 to give 12V output
  - IC2 7806 to give 6V output, with resistor  $R3=47\Omega$  to restrict the charging current.
  - IC3 7805 to give 5V output, with resistor  $R2=47\Omega$  to restrict charging current to a safer level
  - High value capacitors C1 and C2 4700 $\mu$ F, 16V to act as current buffers so that a short duration interruption in current flow from the panel will not affect the charging process.
  - Red LED 2V, 30mA, to indicate the charging process
  - Diode D1 1N6204 to protect battery current to flow back to solar panel

Calculate the resistance of the resistor to connect in series with a Red LED to restrict the current flow through LED? **[6 Marks]**

- c) Design a 230VAC main supply based multipurpose mobile and laptop charger. A 230VAC main supply is used as source of current. The circuit diagram should be able to charger a 3.7V, 600mA mobile phone battery and 19V, 3.42A laptop battery. The following components should be used in the circuit diagram
- IC1 KIA7820API to give 20V output
  - Use a Zener Diode as regulator to give 3.7V output, with resistor R2 to restrict charging current to a safer level and restrict current through Zener diode
  - High value capacitors C1 and C2 4700 $\mu$ F, 25V to act as current smoother and buffers so that a short duration interruption in current flow from the panel will not affect the charging process.
  - Red LED 2V, 30mA, to indicate the charging process
  - Diode D1 1N6204 to protect battery current to flow back to solar panel
  - Diode D2-D5 1N6204 for converting AC to DC
  - A step down transformer 240/19V 7000mA **[6Marks]**

- a) Calculate the resistance of the resistor to connect in series with a Red LED to restrict the current flow through LED. **[1 Mark]**
- b) Calculate the resistance of the resistor to limit the current through the Zener diode and the resistor power rating. **[2 Mark]**
- c) Calculate the Zener power rating. **[1 Mark]**

**Total [20Marks]**

## QUESTION THREE

- a) Explain briefly how you would test the following components using a digital multimeter. **[8Marks]**
- i) Diode

- ii) NPN transistor
  - iii) Resistor
  - iv) Capacitor
- b) Outline series of logical steps you would use to speed up the troubleshooting process in fault finding of any instrument. **[5Marks]**
- c) The circuit in figure Q1 works on the principle that when the switch S is closed the LED is turned on. But the LED does not turn on even if S is closed, describe the troubleshooting process you would use to rectify the fault. **[7Marks]**

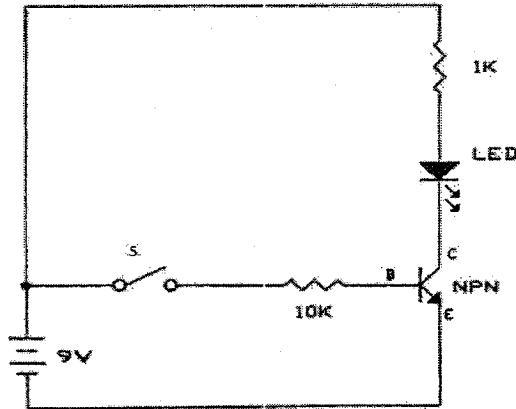

Figure Q3.

**Total [20Marks]**

**QUESTION FOUR**

- a) A 1mA meter movement with an internal resistance of  $100\Omega$  is to be converted into an ammeter with ranges of 10 mA 50 mA and 100 mA. With the help of a diagram calculate the value of shunt resistances required for the ranges. **[8Marks]**
- b) Figure Q4.b for Wheatstone bridge is shown below with resistances  $R_1 = 220\Omega$ ,  $R_2 = 550\Omega$  and  $R_4 = 1000\Omega$ . Calculate the resistance  $R_3$ . **[5Marks]**

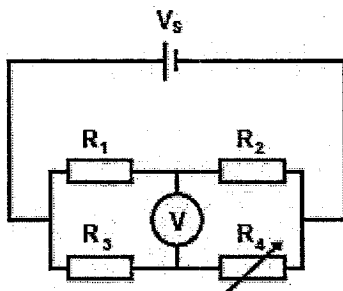

Figure Q4.b

- c) A  $50\ \mu\text{A}$  meter movement with an internal resistance of  $200\Omega$  is to be converted into an ammeter with ranges of 10 V and 20 V. With the help of a diagram calculate the value of multiplier resistances required for the ranges. **[3Marks]**

- d) Figure Q4.d shows an ac voltmeter using full wave bridge rectifier. If the ac voltage to the input terminals is 10V rms find the reading of the galvanometer in volts. [4Marks]

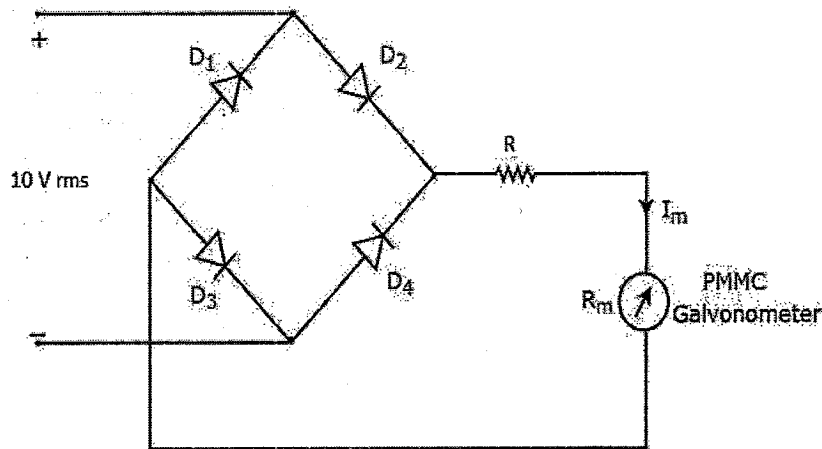

Figure Q4.d AC Voltmeter

Total [20Marks]

**SECTION B: YOU MUST ANSWER ONE (1) QUESTION FROM THIS SECTION**

**QUESTION FIVE**

A beam, which is supported through pin joints at its ends, is acted upon by a couple  $M$  in a plane containing the axis of the beam, applied at a point three quarters of the span from one end.

Find expressions for the:

- (a) slope of the beam at both ends
- (b) maximum deflection.

[10 Marks]

[10 Marks]

Total [20Marks]

**QUESTION SIX**

You have been commissioned to design the suspension for a new sports utility vehicle (SUV). The net weight of the SUV is 3500kg, distributed 45% on the rear axle and 55% on the front axle. When fully loaded an additional 1000kg is added to the SUV, distributed 60% on the rear axle and 40% on the front axle. You are using, on the front axle 2 identical helical close coiled springs in parallel, and on the rear axle 2 identical leaf springs in parallel. Your design constraint is, completely unloaded to fully loaded, the maximum static deflection on either axle should not exceed 20 cm. given for:

Helical spring:

- Mean coiled diameter = 30cm
- Modulus of rigidity = 83.5 GN/m<sup>2</sup>
- Wire diameter = 35mm

Leaf spring:

Length	=	1 m
Number of leaves	=	8
Width to thickness ratio	=	8:1
Elastic modulus	=	125 GN/m <sup>2</sup>

Find:

- (a) The number of complete coils required in the helical springs [5Marks]
- (b) The width of the leaf springs [5Marks]
- (c) The deflection at both axles when acted upon the net weight of the pickup only. [5Marks]

If the distance between the rear and front axle is 4 m what is the magnitude and direction of the shift in the centre gravity of the pickup when loaded with the additional 1000kg. [5Marks]

**Total [20Marks]**

### QUESTION SEVEN

You are designing the spring damper system for a 2050 kg luxury motor vehicle. The test road is sinusoidal in undulation with a maximum displacement of 30cm. If the maximum allowable displacement of the vehicle relative to the road is 34cm, determine:

- (a) the damping ratio and state whether it is over, critically or under damped [5Marks]

If the length of one undulation is 5m, and the damping coefficient is 12000kg/s, determine:

- (b) the stiffness of the suspension [4Marks]
- (c) the speed in km/h of the vehicle at maximum displacement [5Marks]
- (d) the maximum displacement of the vehicle if the and the vehicle is moving a 210km/h [6 Marks]

**Total [20Marks]**

**END OF EEE3112 – EXAM**

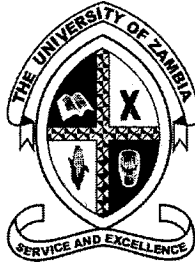

# THE UNIVERSITY OF ZAMBIA

## SCHOOL OF ENGINEERING

### DEPARTMENT OF ELECTRICAL AND ELECTRONIC ENGINEERING

#### UNIVERSITY EXAMINATIONS

NOVEMBER 2021

### **EEE 3352**

### **ELECTROMACHANICS AND ELECTRICAL MACHINES**

---

**TIME** : Three (3) hours

**INSTRUCTIONS** : Answer any five (5) questions

**ADDITIONAL INFORMATION** : *permeability of free space*  $\mu_0 = 4\pi \times 10^{-7}$  H/m  
*permittivity of free space*  $\epsilon_0 = 8.85 \times 10^{-12}$  F/m

---

**Question 1. [20 marks]**

(a) Derive from basic principles the expression for force per unit area due to an electric field.

[8 marks]

(b) Two identical copper plates measuring 15 cm and 10 cm acting as electrodes tightly enclose a slab of mica of thickness 5 mm and relative permittivity of 2.5. Find the

(i) capacitance of the arrangement from the point of view of the electrodes;

[4 marks]

(ii) force on the plates, if 600 V dc is applied between the electrodes;

[4 marks]

(iii) steady-state value of the current through the mica, if 600 V ac at 50 Hz is applied between the electrodes.

[4 marks]

**Question 2. [20 marks]**

(a) Derive the expression of the reluctance  $S$  of a uniform magnetic circuit of constant cross-sectional area  $A$ , relative permeability  $\mu_r$ , length  $l$ . Hence derive the expression for inductance  $L$ , if the coil round the magnetic circuit has  $N$  turns.

[8 marks]

(b) A magnetic core, in the form of a closed circular iron ring, has a mean length of 30 cm and a cross-sectional area of  $1 \text{ cm}^2$ . The relative permeability of iron is 3000.

(i) What dc current is needed in the coil of 2000 turns wound around the ring to create a flux of 0.20 mWb in iron?

[6 marks]

(ii) If two gaps of 1 mm and 0.5 mm, respectively, are cut through the core perpendicular to the direction of the flux and positioned at diametric ends, what current is needed to have the same flux in the air gap as in the iron found in (i)?

[6 marks]

**Question 3. [20 marks]**

(a) Explain the causes of voltage variations at the output of a power transformer on load.

[8 marks]

(b) The results in Table Q3 were obtained for a 20 kVA, 50-Hz, 2200/220-V transformer.

Table Q3

	Side	Voltage (V)	Current (A)	Power (W)
Open circuit test	Low voltage	220	4.2	148
Short circuit test	High voltage	86	10.5	360

What is the regulation of the transformer, when delivering full load at 0.8 power factor lagging and rated primary voltage?

[12 marks]

#### Question 4.

(a) Explain the advantages of having a three-phase system compared to a single-phase system in a power network.

[6 marks]

(b) A star-connected balanced load is supplied from a three-phase supply with a line voltage of 416 V at a frequency of 50 Hz. Each phase of the load consists of a resistance and a capacitor connected in series and the two wattmeters connected to measure load power supplied read 782 W and 1980 W, both positive. For this circuit, what is the

(i) power factor;

[5 marks]

(ii) line current;

[5 marks]

(iii) capacitance of each capacitor?

[4 marks]

#### Question 5.

(a) From " $v = Blu$ ", where  $l$  is the length of a conductor, cutting a magnetic field of density  $B$  at constant speed  $u$ , and experiences an induced voltage  $v$ , derive the expression for the brush terminal voltage for a commutator machine.

[8 marks]

(b) A separately-excited generator has the magnetisation characteristic which gives a no-load voltage of 131 V when driven at 6000 rpm with field excitation of 2000 ampere-turns. The total armature circuit resistance is 0.08  $\Omega$ . If the generator supplies a load current of 120 A, determine the

(i) terminal voltage;

[3 marks]

(ii) power output;

[3 marks]

(iii) the electromagnetic power;

[3 marks]

(iv) electromagnetic torque input.

[3 marks]

#### Question 6.

(a) Three phase ac machines operate on the principle of a "rotating" magnetic flux. Describe the principal features which establish the ac machine as either an induction machine or a synchronous machine.

[4 marks]

(b) A 3-phase, 6-pole induction motor operates on a 50-Hz supply. The frequency of the rotor-induced current is 4 Hz. What is the

(i) slip;

[2 marks]

(ii) speed of the rotor;

[2 marks]

(iii) speed of the rotor mmf with respect to the rotor and with respect to the stator?

[2 marks]

(c) With the help of mmf, voltage and current phasor diagrams explain the operation of an ideal synchronous machine in generating mode.

[10 marks]

**Question 7.**

(a) With the help of equivalent circuits, predict the torque-speed characteristic of the DC Shunt motor.

[6 marks]

(b) Describe the problem of starting d.c. machines and explain, with a suitable sketch, how it is overcome in practice.

[4 marks]

(c) The no-load armature current of a 230-V d.c. shunt motor is 2 A at a speed of 1200 r/min. If the full-load armature current is 40 A, find the full-load speed and the torque developed. Assume that the armature resistance is  $0.25 \Omega$  and the field flux remains unchanged.

[10 marks]

**Question 8.**

(a) Deduce the expression for the relation between the illumination  $E$  and any point on a plane surface due to a light source of luminous intensity  $I$ , suspended at height  $h$  from the surface.

[6 marks]

(b) Two lamps with a rating of 500 W each, with a lamp efficacy of 25 lm/W, are mounted on two lamp posts 10 m apart. The posts have heights of 3 m and 5 m, respectively. Calculate the illuminance at a point mid-way between the lamp posts.

[8 marks]

(c) It is required to provide an illuminance of 100 lx in a factory hall of area 30 m x 12 m. Assume that the maintenance factor is 0.8 and the utilisation factor is 0.4 and the efficacy of the proposed 100-W lamps is 14 lm/W. Calculate the number of lamps.

[6 marks]

---

END OF EEE 3352 EXAMINATION

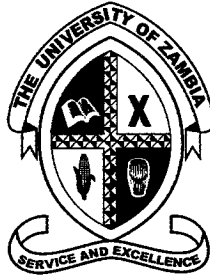

THE UNIVERSITY OF ZAMBIA

SCHOOL OF ENGINEERING

DEPARTMENT OF ELECTRICAL AND ELECTRONIC ENGINEERING

UNIVERSITY EXAMINATIONS DECEMBER 2021

**EEE 3571**

**ELECTRONIC ENGINEERING I**

---

<b>TIME</b>	:	Three (3) hours
<b>INSTRUCTIONS</b>	:	Answer any Five (5) questions
<b>ADDITIONAL INFORMATION</b>	:	<ul style="list-style-type: none"><li>➤ Where not specified take the diode and transistor to be of Silicon.</li><li>➤ A list of some constants and formulas is provided on the last page.</li></ul>

---

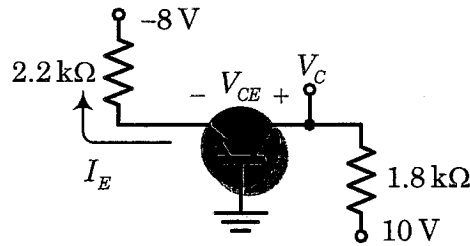

Figure Q2 (c)

**QUESTION 3**

- (a) Name the three common transistor equivalent models that are used in small signal analysis, when determining the gains and impedances of a BJT transistor circuit. [6 Marks]
- (b) For the Emitter Follower network of Figure Q3(b).
  - (i) Calculate  $I_B, I_C$ . [4 Marks]
  - (ii) Determine  $r_e$ . [2 Marks]
  - (iii) Determine  $Z_i$  and  $Z_o$ . [6 Marks]
  - (iv) Calculate  $A_v$ . [2 Marks]

[Total 20 Marks]

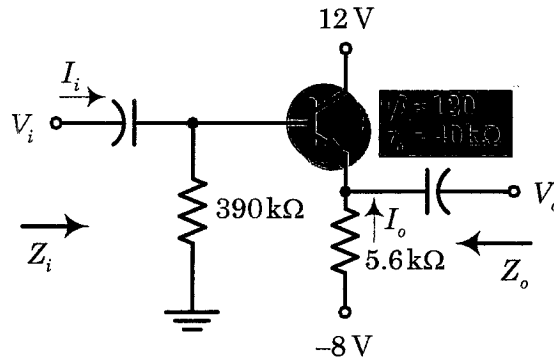

Figure Q3 (b)

**QUESTION 4**

- (a) Consider the active filter network shown in Figure Q4 (a).
  - (i) Derive an expression for the voltage gain as a function of frequency  $\omega$ . [4 Marks]
  - (ii) Hence, sketch the frequency characteristics and describe state what type of filter it is. [6 Marks]

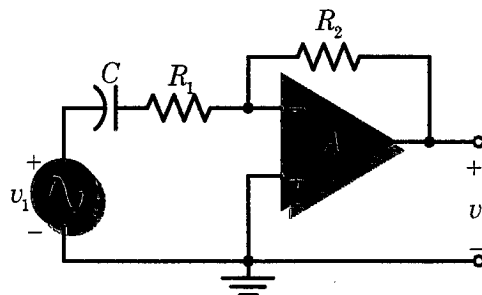

Figure Q4 (a)

**QUESTION 1**

- (a)
  - (i) Determine the thermal voltage for a diode at a temperature of  $T = 100^\circ\text{C}$ . [3 Marks]
  - (ii) For the same diode of part (i), find the diode current if  $I_s = 5\mu\text{A}$ ,  $n = 2$  (low value of  $V_D$ ), and the applied bias voltage is  $0.5\text{V}$ . [3 Marks]
- (b) Figure Q1 (b) shows the Darlington amplifier. Determine:
  - (i) The level of  $\beta_D$ . [2 Marks]
  - (ii) The base current of each transistor. [6 Marks]
  - (iii) The collector current of each transistor. [2 Marks]
  - (iv) The voltages  $V_{C_1}$ ,  $V_{C_2}$ ,  $V_{E_1}$  and  $V_{E_2}$ . [4 Marks]

[Total 20 Marks]

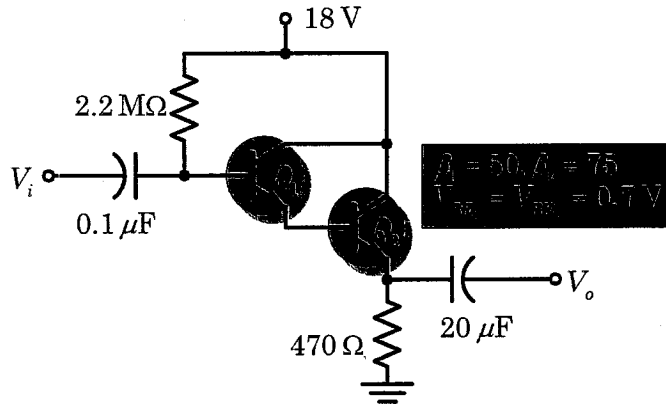

Figure Q1 (b)

**QUESTION 2**

- (a) Name the two types of bipolar junction transistors. [2 Marks]
- (b) The Zener network of Figure Q2 (b) has a fixed load  $R_L$  and variable input voltage  $V_i$ . Determine the range of values of  $V_i$  that will maintain the Zener diode in the ON state. [8 Marks]

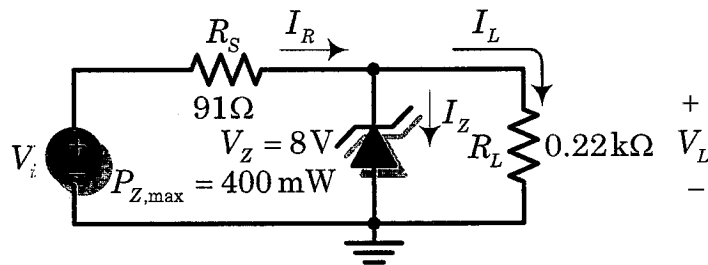

Figure Q2 (b)

- (c) Consider the common-base network of Figure Q2 (c). Determine:
  - (i)  $I_E$ . [4 Marks]
  - (ii)  $V_C$ . [3 Marks]
  - (iii)  $V_{CE}$ . [3 Marks]

[Total 20 Marks]

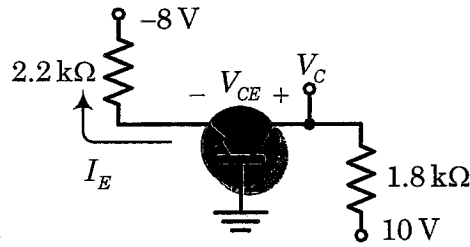

Figure Q2 (c)

**QUESTION 3**

- (a) Name the three common transistor equivalent models that are used in small signal analysis, when determining the gains and impedances of a BJT transistor circuit. [6 Marks]
- (b) For the Emitter Follower network of Figure Q3(b).
  - (i) Calculate  $I_B, I_C$ . [4 Marks]
  - (ii) Determine  $r_e$ . [2 Marks]
  - (iii) Determine  $Z_i$  and  $Z_o$ . [6 Marks]
  - (iv) Calculate  $A_v$ . [2 Marks]

[Total 20 Marks]

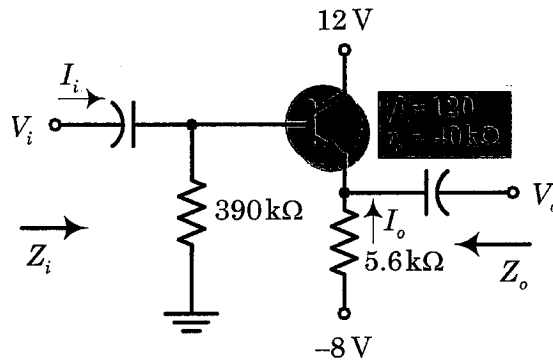

Figure Q3 (b)

**QUESTION 4**

- (a) Consider the active filter network shown in Figure Q4 (a).
  - (i) Derive an expression for the voltage gain as a function of frequency  $\omega$ . [4 Marks]
  - (ii) Hence, sketch the frequency characteristics and describe state what type of filter it is. [6 Marks]

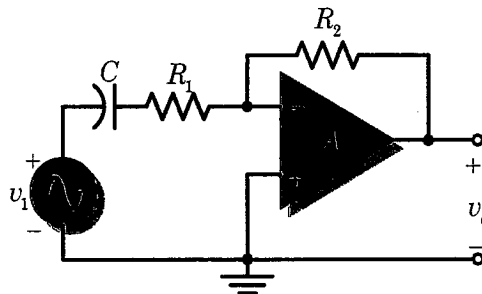

Figure Q4 (a)

(b) For the signals in Figure Q4 (b) (I):

(i) Define  $v_o(t)$  in terms of  $v_{in}(t)$  in words and mathematically. [4 Marks]

(ii) Design a circuit by specifying X and Y in Figure Q4 (b) (II), so that  $v_o(t)$  is obtained from  $v_{in}(t)$ . [6 Marks]

[Total 20 Marks]

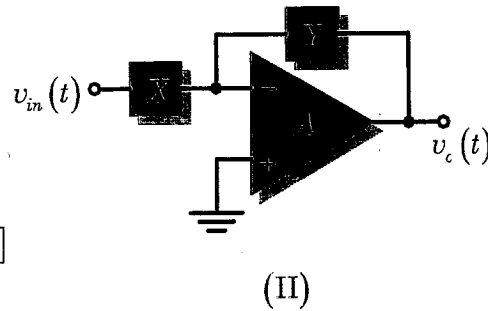
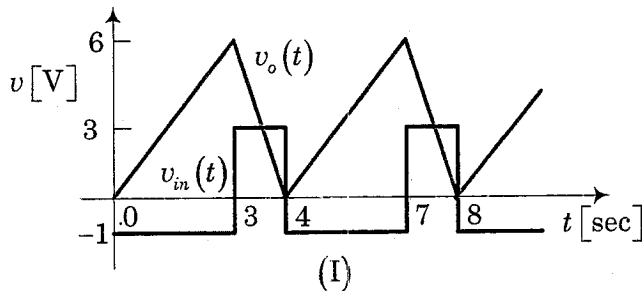

Figure Q4 (b)

**QUESTION 5**

(a) Design an op-amp based **R-2R ladder** digital to analog converter (DAC) to convert the binary number stored in a **4-bit register** into decimal equivalent voltage. Assume the resistor provides input at precisely 0 V and +2 V. [10 Marks]

(b) Consider the network given in Figure Q5 (b)

(i) Derive an expression for the output  $V_o$  in terms of the input voltages  $V_1$  and  $V_2$ . [8 Marks]

(ii) Hence determine the output voltage if  $V_1 = 1V$  and  $V_2 = 0.5V$ . [2 Marks]

[Total 20 Marks]

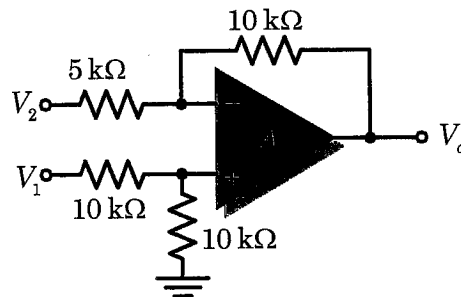

Figure Q5 (b)

**QUESTION 6**

(a) A parallel-comparator Analog-to-Digital Converter (ADC) includes a sample and hold circuit, voltage follower, a 3-comparator stack across  $V_R = 4V$  and ROM code converter.

(i) Draw a labeled schematic diagram and truth table. [4 Marks]

(ii) Determine the digital output of the ROM code converter if the voltage follower output is  $V_i = 1.5V$  and if  $V_i = 3.5V$ . [4 Marks]

(b) For the cascaded system of Figure Q6 (b), determine:

(i) The loaded voltage gain of each stage. [4 Marks]

(ii) The total gain of the system,  $A_{v_L}$  and  $A_{v_S}$ . [4 Marks]

(iii) The total current gain of the system. [2 Marks]

(iv) The total gain for the system if the emitter-follower stage were removed. [2 Marks]

[Total 20 Marks]

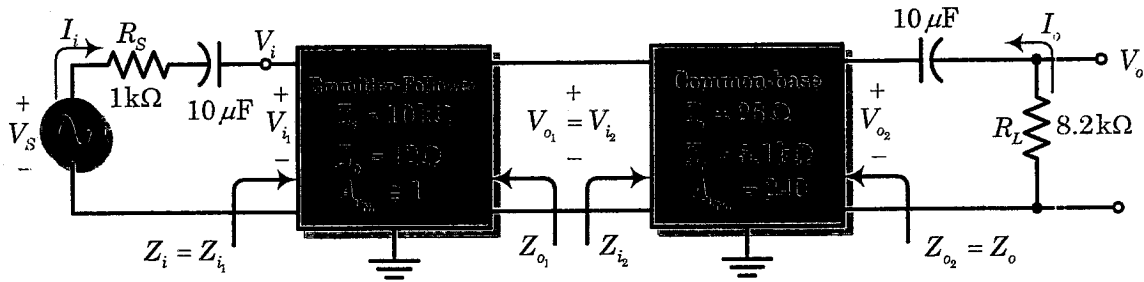

Figure Q6 (b)

**QUESTION 7**

(a) Shown in Figure Q7 (a) is a positive logic gate having two inputs  $V_1$  and  $V_2$ . The input voltages can take up two possible levels 0V and 10V corresponding to logic 0 and logic 1 respectively.

(i) Determine the output level  $V_o$  for all possible input combinations and draw the truth table.

[8 Marks]

(ii) State what type of logic gate it is.

[2 Marks]

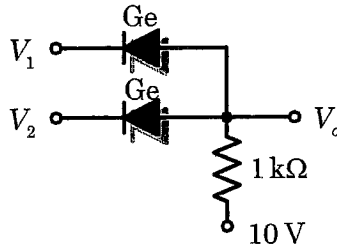

Figure Q7 (a)

(b) Figure Q7 (b) shows a square-wave generator constructed with one op amp operated as a comparator.

(i) Explain how the circuit works assuming  $V_Z = 10V$  and  $R_2 = R_3$ . [6 Marks]

(ii) With the assumption made in part (i) sketch on the same axes the input voltage  $V_1$  and output voltage  $V_o$ . Label all the relevant dimensions. [4 Marks]

[Total 20 Marks]

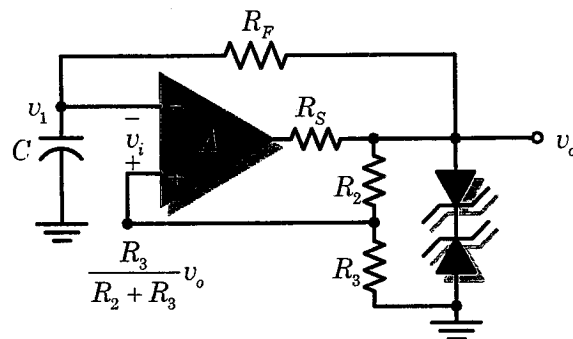
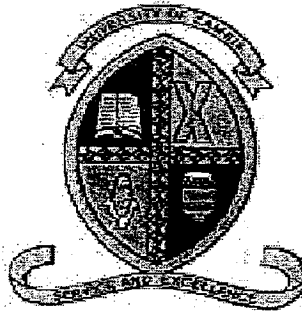

Figure Q7 (b)

**LIST OF FORMULAS AND CONSTANTS**

SN	Formula/Constant	SN	Formula/Constant
1.	$I_D = I_s (e^{V_D/nV_T} - 1)$	5.	Absolute temperature in kelvins, $T_K = 273 + T(^{\circ}\text{C})$
2.	$V_T = \frac{kT_K}{q}$	6.	Germanium (Ge), $V_K = 0.3 \text{ V}$
3.	Boltzmann's constant, $k = 1.38 \times 10^{-23} \text{ J/K}$	7.	Silicon (Si), $V_K = 0.7 \text{ V}$
4.	Electronic charge, $q = 1.602 \times 10^{-19} \text{ C}$	8.	Gallium Arsenide (GaAs), $V_K = 1.2 \text{ V}$

**END OF EEE 3571 EXAM**



**THE UNIVERSITY OF ZAMBIA**

**SCHOOL OF ENGINEERING**

**DEPARTMENT OF ELECTRICAL AND ELECTRONIC ENGINEERING**

**UNIVERSITY EXAMINATION, NOVEMBER 2021**

**EEE 4021**

**ENGINEERING ELECTROMAGNETICS**

---

**TIME** : *Three (3) hours*

**ANSWER** : *Any Four (4) Questions*

**EACH QUESTION CARRIES EQUAL MARKS [25 MARKS]**

**Physical Constant:**  $\epsilon_0 = 8.854 \times 10^{-12}$  (F/m);  $\mu_0 = 4\pi \times 10^{-7}$  (H/m); and  $1Np = 8.686$  dB

---

### Question 1

- (a). Visible light, gamma rays, X-rays, infrared waves and radio waves all belong to the electromagnetic spectrum. Explain why, generically all of them, are called electromagnetic waves [ 3 marks]
- (b). What is the difference between a phasor and a vector? Discuss the advantages of using phasors in electromagnetics. [ 6 marks]
- (c). An electromagnetic wave is propagating in the z-direction in a lossy medium with attenuation constant  $\alpha=0.5 \text{ Np/m}$ . If the wave's electric-field amplitude is  $100 \text{ V/m}$  at  $z = 0$ , how far can the wave travel before its amplitude will have been reduced to  $1 \mu\text{V/m}$ . [ 3 marks]
- (d). In phasor form, the electric field intensity of a uniform plane wave in free space is expressed as
- $$\tilde{\mathbf{E}}(\mathbf{z}) = (40 - j30)e^{-j20z} \hat{\mathbf{x}} \quad \text{V/m}$$
- (i) Is this a standing wave or a traveling wave? Explain why. [6 marks]
- (ii) What is its wave number? Is it dependent on frequency? [3 marks]
- (iii) What is its angular velocity? Is it dependent on frequency? [2 marks]
- (iv) What is the period of this wave? What is its wavelength? [2 marks]

### Question 2

- (a). For which minimum value of the ratio  $\ell/\lambda$  ( $\ell$  and  $\lambda$  being the length of the transmission line and the wavelength down the line respectively), the transmission-line effects may not be ignored. Name and explain in details the negative effects occurring beyond that value. [ 6 marks]
- (b). Show that for a distortionless line,
- $$\alpha = R' \sqrt{\frac{C'}{L'}} = \sqrt{R'G'}, \quad \beta = \omega \sqrt{L'C'}, \quad u_p = \frac{1}{\sqrt{L'C'}} \quad [ 7 \text{ marks}]$$
- (c). Show that the input impedance of a quarter-wavelength long lossless line terminated in a short circuit appears as an open circuit. [ 6 marks]
- (d). Show that at the position where the magnitude of the voltage on the line is a maximum the input impedance is purely real. [ 6 marks]

### Question 3

- (a). Why is the electric field  $\mathbf{E}$  immediately outside of a perfect conductor perpendicular to the conductor surface? [ 3 marks]
- Why is the magnetic field  $\mathbf{H}$  immediately outside of a perfect conductor tangential to the conductor surface? [ 3 marks]
- (b). Overhead transmission lines generate an electric field everywhere in space. The electric field intensity must be kept low enough for safety reasons. Consider a very long (infinite) line, located at a distance  $d = 10 \text{ m}$  above ground and charged with a uniform, line charge density  $\rho_l = 10^{-7} \text{ C/m}$  as shown in FigQ3-1. Neglect the ground's influence:

- (i) Calculate the electric field intensity everywhere in space. [ 4 marks]  
 (ii) What is the magnitude of the electric field intensity at ground level, directly below the line?. [ 5 marks]

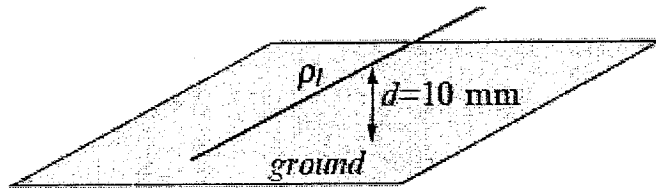

FigQ3-1

- (b). An interface between two dielectrics coincides with the  $z = 0$  plane as shown in Fig.Q3-2. The electric field intensity in medium (1) is

$$\mathbf{E}_1 = \hat{x} 100 + \hat{y} 300 - \hat{z} 50 \text{ V/m.}$$

A surface charge density  $\rho_s = 5 \times 10^{-10} \text{ C/m}^2$  exists on the interface. Calculate:

- (i). The electric field intensity in medium (2). [ 6 marks]  
 (ii) The electric flux density in medium (2). [ 4 marks]

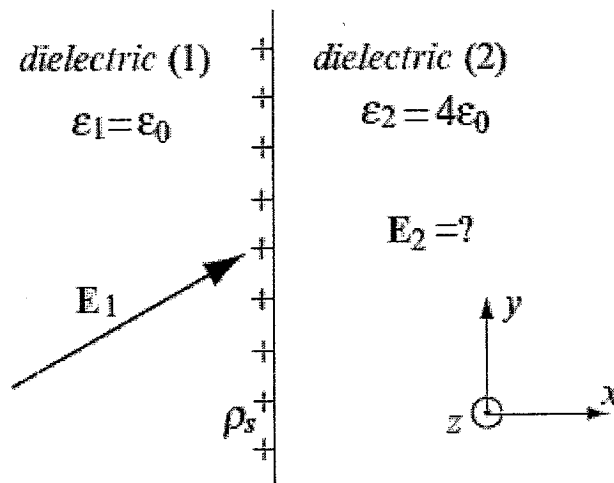

Fig.Q3-2

#### Question 4

(a). Obtain expressions for the conductance, capacitance and inductance per meter respectively for a coaxial cable of length  $l$  and inner and outer radii  $a$  and  $b$ . The current flowing through the cable is  $I$  and its insulation material has linear properties of permittivity  $\epsilon$ , conductivity  $\sigma$  and permeability  $\mu$ . Hence, derive then the expression of electrostatic potential energy and magnetic energy stored in the coaxial cable. [ 4x5 marks]

(b) The current flowing through the cable is  $I$  and its insulation material has linear properties of permittivity  $\epsilon$ , and permeability  $\mu$ . Hence, derive then the magnetic energy stored in the coaxial cable. [ 5 marks]

### Question 5

- (a). The magnetic field intensity in a cylindrical conductor of radius  $a$  is given as

$$\mathbf{H} = \hat{\phi} 5r$$

where  $r$  is the distance from the center of the conductor ( $r < a$ ) and the axis of the cylinder is along the  $z$  axis. The conductivity equals  $10^7 \text{ S/m}$ . Calculate the electric field intensity in the conductor using the Ampere's Law in magnetostatic field. [ 12 marks]

(b). Two very thin conducting sheets(plates) in  $x$ - $y$  plane carry current surface densities  $J_s$  in  $x$ -direction as shown in the figure Fig.Q5. The upper sheet carries a current density  $J_{1s}$  [A/m] flowing into the page. The lower sheet carries a current density  $J_{2s}$  [A/m], flowing out of the page. A thin insulating layer is placed between the two sheets. Assuming the sheets to be very large (essentially infinite) and the current density to be uniform, calculate:

- (i). The magnetic field intensity outside the 2 sheets (above and below the two plates). [ 7 marks]
- (ii). The magnetic field intensity in the insulating between the two sheets. [ 6 marks]

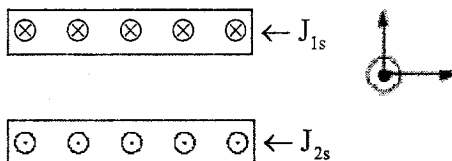

Fig.Q5

### Question 6

(a). Write the differential form and integral form of Maxwell's equations respectively, and identify them with known (proper experimental) Laws. [ 4x1.5 marks]

(b). A DC generator can be built as shown in Fig. Q6-1. The sliding bar, load, and rails form a closed circuit. The two rails are separated a distance  $d = 1.5 \text{ m}$  and the load resistance is  $R = 10 \Omega$ . Assume the rails and bar are perfectly conducting and the bar moves to the right at a constant velocity  $v = 10 \text{ m/s}$ . The magnetic flux density is constant, directed out of the page, and equal to  $B = 0.1 \text{ T}$ . Calculate:

- (i) The electromotive force produced by this DC generator. [ 4 marks]
- (ii) The mechanical force  $F_a$  required to counteract the magnetic force  $F_m$  which the magnetic field exerts on the current-carrying metal bar. [ 4 marks]
- (iii) The mechanical power required to move the bar at constant velocity for generation and giving the power of the applied force  $F_a$ . [ 3 marks]
- (iv) Show that this mechanical power is equal to the power dissipated through Joule's losses which in the resistance  $R$ , using the current  $I$ . [ 2 marks]

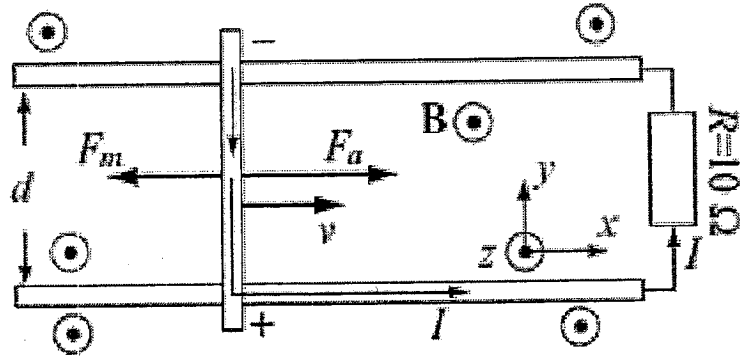

Fig. Q6-1

(d). The operation of an AC generator may be explained in more details using the coordinate systems shown in Fig. Q6-2. The magnetic field is given by  $\mathbf{B} = \hat{z} B_0$  and the axis of rotation of the conducting loop is along the x-axis. Segments 1-2 and 3-4 of the loop are of length  $l$  each, and both cross the magnetic flux lines as the loop rotates. The other two segments are each of width  $w$ , and neither crosses the magnetic the  $\mathbf{B}$  lines when the loop rotates; its angular velocity being  $\omega$  about its own axis. The segment 1-2 moves with a linear velocity  $\mathbf{u}$ . Derive the expression of the expression of the motional electromotive force  $V_{emf}^m$ .

[ 6 marks]

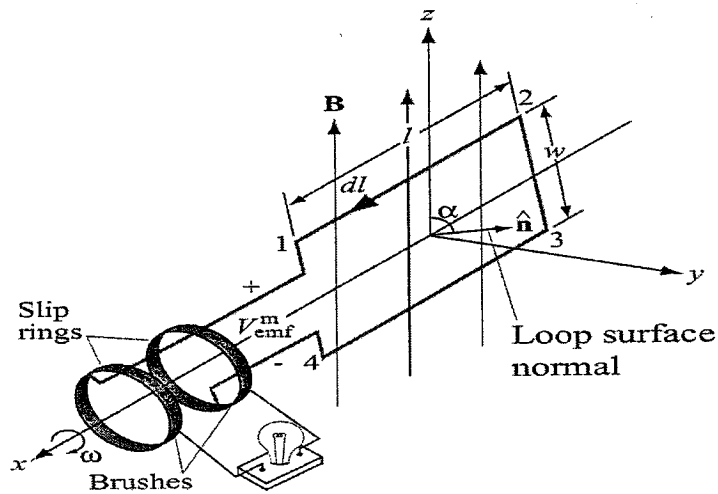
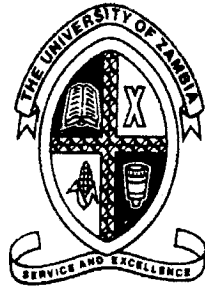

Fig. Q6-2.

**END OF EXAMINATION.**



# THE UNIVERSITY OF ZAMBIA

SCHOOL OF ENGINEERING

Department of Electrical and Electronic Engineering

## **EEE 4135: Microcontroller Technology and Embedded Systems**

TERM I EXAM – NOVEMBER 2021

---

<b>TIME</b>	: Three (3) hours
<b>INSTRUCTIONS</b>	: Answer any five (5) questions
<b>ADDITIONAL INFORMATION</b>	: <i>All Questions Carry Equal Marks, some questions require the use of information provided in the appendix.</i>

---

## Question 1

- a. List four (4) number systems and their radices (i.e. number bases). [1/2+1/2+1/2+1/2]
- b. Give two (2) advantages of Embedded C over Assembly Language. [1+1]
- c. Give two (2) IC Package configurations of typical AVR microcontrollers. [1+1]
- d. The processor lies at the core of embedded hardware. List three (3) types that can be found in a typical embedded system. [3]
- e. Why is the hexadecimal system usually used to represent EBCDIC code? [1]
- f. List two (2) common coding systems in use in computing systems. [2]
- g. Represent the letter 'F' into EBCDIC code. (*Note; for upper case we put a 10 in the first two characters of the zone*).

Code	Range
00	A to I
01	J to R
10	S to Z
11	numbers

- [2]
- h. Give two (2) reasons why it is important to know the architecture of a microcontroller. [2]
- i. Calculate the digital value (ADC value) of an LM35 temperature transducer if we have a 50-degree temperature, given scale factor = 20.0 mV/°C. Use  $V_{max} = 10V$ , and the formula;
- $$\frac{e}{V_{max}} = \frac{d}{2^n - 1}$$
- [1+1]
- j. In the MC1408 (DAC0808), the digital inputs are converted to current ( $I_{out}$ ). The total current provided by the  $I_{out}$  pin is a function of the binary numbers at the DO – D7

inputs of the DAC0808 and the reference current ( $I_{ref}$ ). Given  $I_{ref} = 10A$ , calculate  $I_{out}$  for binary inputs 0b10100000 and 0b11110001.

[2]

### Question 2

- a. Why is the **OUT** instruction preferred to the **STS** for storing values in an IO register? [1]
- b. What is the maximum allowable size of code written for ATmega328P? [1]
- c. What is the maximum size of RAM in AVR microcontrollers? [1]
- d. AVR microcontrollers use RISC architecture. What is RISC and why is it the architecture of choice for AVR? [2+2]
- e. Describe the principle of operation of the ultra-sonic sensor. [3]
- f. Write an AVR assembly code for the Atmega328P that will loop **2,500,000** times by using the DEC and BRNE. Within the loop, let the output on port B be 0b10101010 on the first pass and then its complement (COM) on the second pass and then alternating in that fashion during each pass (2,500,000 times).

[10]

### Question 3

- a. What is the STACK and STACK POINTER? [2]
- b. Write instructions to initialize the stack. Use `low(RAMEND)/high(RAMEND)`. [4]
- c. What is the combined instructions used to manipulate data in RAM referred to? [1]
- d. What is the content of D7 (I) of SREG register upon reset, and what does it mean? [1]
- e. PORTC is initialized to 0x00. Write an expression to set PORTC to 0b01101011. [1]
- f. Write an expression to clear the third (3) bit in PORTC. [1]
- g. When are the *carry* and *overflow* flags set in the status register? [1+1]
- h. Name the two categories of datatypes used to represent real numbers. [1+1]
- i. A program sends values 0x00 to 0xFF to Port B, a new value after one second. What datatype would be suitable for such values? [1]
- j. In embedded systems programming, the “Hello World” Equivalent is “Blink” i.e. having a blinking LED on one of the output pins. Complete the code below to blink an LED every 5 seconds at output PORTB.

```
#define F_CPU 8000000UL
```

```

#include<avr/io.h>
#include<util/delay.h>
int main()
{
    //initialize PORTB
    while(1)
    {
        // toggle PORTB with _delay_ms()
    }
}

```

[5]

#### Question 4

a. What is the purpose of the Interrupt Service Routine (ISR)?

[1+1]

b. Write instructions to load R5 with decimal 37 (0x25)

[1+1]

c. What is the process through which the processor controls the execution of instructions? List the three continuous steps of this process.

[1+3]

d. What steps need to be taken to enable an interrupt?

[1+1]

e. What are the results of performing the following operations;

a = 00000001<<1

b = 00001111<<3

c = 0x01<<2

[3]

f. What happens if an interrupt is activated while the CPU is serving another interrupt?

[1+1]

- g. In embedded systems programming, the “Hello World” Equivalent is “Blink” i.e. having a blinking LED on one of the output pins. Complete the instructions below to toggle an LED every time the delay function completes execution at output PORTB (write statements that go in the commented lines).

```
.INCLUDE "m328pdef.inc"
```

```
LDI R16, 0x55 ;load R16 with 0x55
```

```
BACK:
```

```
;ones complement of contents of R16
```

```
;send the contents of R16 to port B register (actual pins)
```

```
;call a function called DELAY
```

```
;relative jump to BACK i.e. keep doing this indefinitely
```

```
DELAY:
```

```
LDI R20, 32 ;number of decrements for outer loop
```

```
L1: LDI R21, 200 ;number of decrements for middle loop
```

```
L2: LDI R22, 250 ;number of decrements for innermost loop
```

```
L3: NOP
```

```
NOP
```

```
DEC R22
```

```
BRNE L3
```

```
DEC R21
```

```
BRNE L2
```

```
DEC R20
```

```
BRNE L1
```

```
RET
```

[5]

### Question 5

a. Give two (2) uses of AVR Timers/Counters.

[1+1]

b. For a timer on the Atmega328P (running on internal 8MHz oscillator), calculate the timer resolution.

[1]

c. List the four (4) fields that consist of an Assembly Language statement

[4]

d. Define the following Timer/counter parameters;

- Bit Resolution
- Ticks
- Counter Bottom
- Counter Top

[1+1+1+1]

e. For AVR, there are a number of programmers in use. The programmers can be 10 pin or 6 pin. List the common types of programmers.

[3]

f. Complete the following code to read the ADC value.

```
uint16_t adc_read (uint8_t ch )
{
// select the corresponding channel 0~7
// start single conversion
// wait for conversion to complete, ADSC becomes '0' again
return (ADC)
}
```

[6]

### Question 6

- a. List all five components of the task structure of a typical Embedded System; give a brief description, and give an example for each task.

[1+1+1+1+1]

- b. List three (3) common microcontrollers used in Embedded Systems.

[1+1+1]

- c. What is the difference between primary and secondary datatypes?

[1+1]

- d. Explain why for two microcontrollers to communicate serially they should have the same baud rate?

[1]

- e. Initialise AVR ADC with  $A_{ref} = V_{cc}$  and a prescalar of 128. Use the appendix for register description (use embedded C statements).

[5]

- f. Complete the following code by writing statements in the commented lines. The code toggles the D7 pin of PORTB every millisecond. Calculate the target timer count assuming a clock frequency of 16 MHz and prescalar of 64. Refer to the appendix for register description.

```
#include<avr/io.h>

int main()
{
    DDRB |= (1<<0);
    //configure Timer/Counter0 with prescalar 64
    while(1)
    {
```

```

if (//Timer/Counter >= target timer count)
{
    //toggle pin 7 of PORTB
    //reset Timer/Counter
}
}
}

```

[4]

### Question 7

a. Name four (4) features of a microcontroller.

[1+1+1+1]

b. What are actuators?

[1]

c. For a 16-bit counter, determine the pulse number that will reset the counter, and the clock cycles that it takes to get from bottom to the top.

[1+1]

d. When a particular data set is in the microcontroller, it is in *parallel* form. Briefly explain how microcontrollers communicate *serially* given the data set is in parallel form in the microcontroller.

[1+1]

e. What advantage does synchronous transmission have over asynchronous transmission?

[1+1]

f. Since microcontrollers cannot provide the power needed to run the DC motors, what is required to provide the power needed to run the DC motors?

[1]

- g. Write a function to initialize UART in C to receive and transmit bytes of data. Set the baud rate at 9600bps, 8-bit data and 1 stop bit. Assume oscillating frequency of 8MHz. Use the appendix for register description.

[8]

THE END

# Appendix

## A1: Timers and Counters

### Timer/Counter Interrupt Mask Register - TIMSK;

Bit 7 - OCIE2: Timer/Counter2 Output Compare Match Interrupt Enable

Bit 6 - TOIE2: Timer/Counter2 Overflow Interrupt Enable

Bit 5 - TICIE1: Timer/Counter1 Input Capture Interrupt Enable

Bit 4 - OCIE1A: Timer/Counter1 Output Compare A Match Interrupt Enable

Bit 3 - OCIE1B: Timer/Counter1 Output Compare B Match Interrupt Enable

Bit 2 - TOIE1: Timer/Counter1 Overflow Interrupt Enable

Bit 1 - OCIE0: Timer/Counter0 Output Compare Match Interrupt Enable

Bit 0 - TOIE0: Timer/Counter0 Overflow Interrupt Enable

### TCCR0B: Timer/Counter0 Control Register B;

Bit	7	6	5	4	3	2	1	0	
0x25 (0x45)	FOC0A	FOC0B	-	-	WGM02	CS02	CS01	CS00	TCCR0B
Read/Write	W	W	R	R	R/W	R/W	R/W	R/W	
Initial Value	0	0	0	0	0	0	0	0	

CS02	CS01	CS00	Description
0	0	0	No clock source (Timer/Counter stopped)
0	0	1	$clk_{IO}/1$ (No prescaling)
0	1	0	$clk_{IO}/8$ (From prescaler)
0	1	1	$clk_{IO}/64$ (From prescaler)
1	0	0	$clk_{IO}/256$ (From prescaler)
1	0	1	$clk_{IO}/1024$ (From prescaler)
1	1	0	External clock source on T0 pin. Clock on falling edge.
1	1	1	External clock source on T0 pin. Clock on rising edge.

## TCCR1A and TCCR1B: Timer/Counter1 Control Register A (and B);

Bit	7	6	5	4	3	2	1	0	
(0x80)	<b>COM1A1 COM1A0 COM1B1 COM1B0 - - WGM11 WGM10</b>								<b>TCCR1A</b>
Read/Write	R/W	R/W	R/W	R/W	R	R	R/W	R/W	
Initial Value	0	0	0	0	0	0	0	0	
Bit	7	6	5	4	3	2	1	0	
(0x81)	<b>ICNC1 ICES1 - WGM13 WGM12 CS12 CS11 CS10</b>								<b>TCCR1B</b>
Read/Write	R/W	R/W	R	R/W	R/W	R/W	R/W	R/W	
Initial Value	0	0	0	0	0	0	0	0	

Mode	WGM13	WGM12 (CTC1)	WGM11 (PWM11)	WGM10 (PWM10)	Timer/Counter Mode of Operation	TOP	Update of OCR1x	TOV1 Flag Set on
0	0	0	0	0	Normal	0xFFFF	Immediate	MAX
1	0	0	0	1	PWM, Phase Correct, 8-bit	0x00FF	TOP	BOTTOM
2	0	0	1	0	PWM, Phase Correct, 9-bit	0x01FF	TOP	BOTTOM
3	0	0	1	1	PWM, Phase Correct, 10-bit	0x03FF	TOP	BOTTOM
4	0	1	0	0	CTC	OCR1A	Immediate	MAX
5	0	1	0	1	Fast PWM, 8-bit	0x00FF	TOP	TOP
6	0	1	1	0	Fast PWM, 9-bit	0x01FF	TOP	TOP
7	0	1	1	1	Fast PWM, 10-bit	0x03FF	TOP	TOP
8	1	0	0	0	PWM, Phase and Frequency Correct	ICR1	BOTTOM	BOTTOM
9	1	0	0	1	PWM, Phase and Frequency Correct	OCR1A	BOTTOM	BOTTOM
10	1	0	1	0	PWM, Phase Correct	ICR1	TOP	BOTTOM
11	1	0	1	1	PWM, Phase Correct	OCR1A	TOP	BOTTOM
12	1	1	0	0	CTC	ICR1	Immediate	MAX
13	1	1	0	1	Reserved	-	-	-
14	1	1	1	0	Fast PWM	ICR1	TOP	TOP
15	1	1	1	1	Fast PWM	OCR1A	TOP	TOP

## A2: The ADC of AVR

### ADMUX – ADC Multiplexer Selection Register;

Bit	7	6	5	4	3	2	1	0	
	<b>REFS1 REFS0 ADLAR MUX4 MUX3 MUX2 MUX1 MUX0</b>								<b>ADMUX</b>
Read/Write	R/W	R/W	R/W	R/W	R/W	R/W	R/W	R/W	
Initial Value	0	0	0	0	0	0	0	0	

REFS1	REFS0	Voltage Reference Selection
0	0	AREF, Internal Vref turned off
0	1	AVCC with external capacitor at AREF pin
1	0	Reserved
1	1	Internal 2.56V Voltage Reference with external capacitor at AREF pin

### ADCSRA – ADC Control & Status Register A;

Bit	7	6	5	4	3	2	1	0	
	<b>ADEN</b>	<b>ADSC</b>	<b>ADATE</b>	<b>ADIF</b>	<b>ADIE</b>	<b>ADPS2</b>	<b>ADPS1</b>	<b>ADPS0</b>	<b>ADCSRA</b>
Read/Write	R/W	R/W	R/W	R/W	R/W	R/W	R/W	R/W	
Initial Value	0	0	0	0	0	0	0	0	

Bit 7 – ADEN – ADC Enable

Bit 6 – ADSC – ADC Start Conversion

Bit 4 – ADIF – ADC Interrupt Flag

Bits 2:0 – ADPS2:0 – ADC Prescaler Select Bits

ADPS2	ADPS1	ADPS0	Division Factor
0	0	0	2
0	0	1	2
0	1	0	4
0	1	1	8
1	0	0	16
1	0	1	32
1	1	0	64
1	1	1	128

### A3: Serial Communication

The table below shows the equations for calculating baud rate and UBRR value:

Operating Mode	Equation for Calculating Baud Rate <sup>(1)</sup>	Equation for Calculating UBRR Value
Asynchronous Normal mode (U2X = 0)	$BAUD = \frac{f_{osc}}{16(UBRR + 1)}$	$UBRR = \frac{f_{osc}}{16BAUD} - 1$
Asynchronous Double Speed Mode (U2X = 1)	$BAUD = \frac{f_{osc}}{8(UBRR + 1)}$	$UBRR = \frac{f_{osc}}{8BAUD} - 1$
Synchronous Master Mode	$BAUD = \frac{f_{osc}}{2(UBRR + 1)}$	$UBRR = \frac{f_{osc}}{2BAUD} - 1$

**UCSRB: USART Control and Status Register B (8-bit);**

Bit	7	6	5	4	3	2	1	0	
	RXCIE	TXCIE	UDRIE	RXEN	TXEN	UCSZ2	RXB8	TXB8	UCSRB
Read/Write	R/W	R/W	R/W	R/W	R/W	R/W	R	R/W	
Initial Value	0	0	0	0	0	0	0	0	

Bit 7: RXCIE – RX Complete Interrupt Enable

Bit 6: TXCIE – TX Complete Interrupt Enable

Bit 5: UDRIE – USART Data Register Empty Interrupt Enable

Bit 4: RXEN – Receiver Enable

Bit 3: TXEN – Transmitter Enable

Bit 2: UCSZ2 – Character Size

Bit 1: RXB8 – Receive Data Bit 8

Bit 0: TXB8 – Transmit Data Bit 8

**UCSRC: USART Control and Status Register C (8-bit);**

Bit	7	6	5	4	3	2	1	0	
	URSEL	UMSEL	UPM1	UPM0	USBS	UCSZ1	UCSZ0	UCPOL	UCSRC
Read/Write	R/W	R/W	R/W	R/W	R/W	R/W	R/W	R/W	
Initial Value	1	0	0	0	0	1	1	0	

Bit 7: URSEL – USART Register Select: This bit selects between accessing the UCSRC or the UBRRH Register. It is read as one when reading UCSRC. The URSEL must be one when writing the UCSRC.

Bit 6: UMSEL – USART Mode Select: This bit selects between Asynchronous and Synchronous mode of operation. Refer to the table below;

UMSEL	Mode
0	Asynchronous Operation
1	Synchronous Operation

**THE UNIVERSITY OF ZAMBIA**  
**SCHOOL OF ENGINEERING**  
**DEPARTMENT OF ELECTRICAL & ELECTRONIC ENGINEERING**  
**UNIVERSITY TERM II EXAMINATIONS NOVEMBER 2021**

EEE 4221  
Digital Signal Processing

**Time: Three hours**

**Answer five questions.**

### Question One

A digital communication link carries binary-coded words representing samples of an input signal given by equation 1.1. The ADC in the transmitter has a sampling frequency,  $f_s$  of 1000 kHz and produces a word length of 10bits.

$$x_a(t) = \sin 600\pi t + 2 \cos 1800\pi t \quad 1.1$$

- Is this sampling frequency sufficient for  $x_a(t)$ , if it is to be sampled without any distortion being introduced? Show your working. **[5 Marks]**
- Once sampling is carried out what are the frequencies in the resulting discrete-time signal  $x[n]$ . **[6 Marks]**
- Assuming that the desired component in  $x_a(t)$  is the one with the lower frequency, an antialiasing filter can be used to ensure that only this frequency is digitised. State what type of filter can be used for this purpose and give an example of the cutoff frequency/frequencies which can be used in Hz. **[4 Marks]**
- Assuming that the ADC has an input voltage range of 0 to 5V what is its resolution? **[5 Marks]**

### Question Two

The impulse response of a system is given by equation 2.1 whilst the excitation to the system is given by equation 2.2.

$$h[n] = 2\sin\left(\frac{n\pi}{2}\right) (u[n+3] - u[n-4]) \quad 2.1$$

$$x[n] = 0.5n (u[n] - u[n-6]) \quad 2.2$$

- Draw the sequences  $x[n]$  and  $h[n]$  for  $-5 < n < 9$ . **[10 Marks]**
- Calculate the response of the system (You are free to use ANY technique that applies to LTI systems). **[10 Marks]**

### Question Three

- With regards to implementing a Fourier transform algorithm on hardware what are the two main problems with the Discrete Time Fourier transform (DTFT) that the Discrete Fourier Transform (DFT) helps to solve. **[2 Marks]**
- Determine the DTFT of  $x[n] = \{1, 1, \underline{1}, 1, 1\}$  ( $n=0$  sample is underlined). **[6 Marks]**
- Compute the 4 point DFT of the signal  $x[n] = \{0, 1, 2, 3\}$  using a method of your choice. **[10 Marks]**
- Explain what zero padding is and why it is used with the DFT. **[2 Marks]**

#### Question Four

An FIR filter is described by the difference equation

$$y[n] = x[n] + x[n - 10]$$

- Determine the filter's frequency response; provide both the amplitude and phase characteristics. [5 Marks]
- Sketch the amplitude response by using the points for  $\omega=0, 0.2, 0.3$  and  $0.5$ , make sure to appropriately label the  $x$  and  $y$ -axis. [5 Marks]
- Determine the filters response to the following input:

$$x[n] = 10 + \cos \frac{\pi}{10}n + 3 \sin \left( \frac{\pi}{3}n + \frac{\pi}{10} \right)$$

[8 Marks]

- Are any components of the input signal suppressed by the filter, if so indicate which components have been suppressed. [2 Marks]

#### Question Five

The difference equation of a causal IIR filter is given by the equation

$$y[n] = \frac{3}{4}y[n - 1] - \frac{1}{8}y[n - 2] + x[n]$$

- Determine the impulse response of this system. [7 Marks]
- Plot the pole-zero pattern. [4 Marks]
- Is the system BIBO stable? Give reasons for your answer based on the pole-zero plot. [3 Marks]
- Determine the step response of the system [6 Marks]

#### Question Six

We want to design a causal discrete LTI system with the property that if the input is

$$x[n] = \left(\frac{1}{2}\right)^n u[n] - \frac{1}{4} \left(\frac{1}{2}\right)^{n-1} u[n - 1]$$

then the output is

$$y[n] = \left(\frac{1}{3}\right)^n u[n]$$

- Determine the impulse response  $h[n]$  and the system function  $H(z)$ . [10 Marks]
- Find the difference equation that characterizes this system. [6 Marks]
- Is the system stable? When implementing the system practically why is system stability important? [4 Marks]

**Question Seven**

- a) What are the two main differences between analogue and digital signal processing with regards to the amplitude and time characteristics. **[2 Marks]**
  
- b) What is the minimum sampling frequency required in order to correctly sample any signal (use a mathematical expression to help explain)? **[4 Marks]**
  
- c) Figure 7.1 shows the spectral plot of a signal that is composed of two sinusoids; the first at 10 Hz and the other at 300 Hz. In order to process this signal using DSP it is proposed that it should be sampled with sampling frequency  $f_s$  of 500 Hz. As the design engineer you have been tasked to confirm if this sampling frequency will be adequate to ensure sampling does not introduce any signal distortion. State if distortion will or will not be introduced and justify your answer by plotting another spectral plot similar to that given in the figure. This figure should show the resulting spectrum if sampled with the proposed frequency. **[5 Marks]**

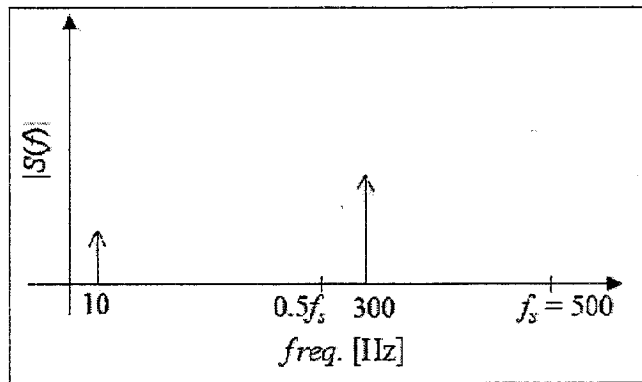
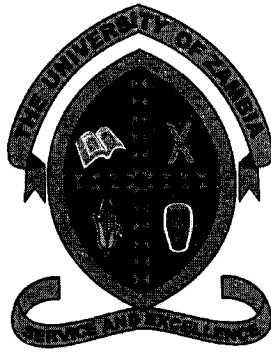

Figure 7.1: Signal amplitude spectral plot

- d) The filter kernel of a 3 point moving average is given by  $h[n] = \{1/3, \underline{1/3}, 1/3\}$  determine the difference equation for this system (note the underlined coefficient refers to  $n=0$ ). **[4 Marks]**
  
- e) Plot the pole-zero diagram for  $x[n]=0.5^n u[n]$  clearly showing the ROC. **[5 Marks]**

	Sequence	Fourier Transform
1.	$\delta[n]$	1
2.	$\delta[n - n_0]$	$e^{-j\omega n_0}$
3.	1 $(-\infty < n < \infty)$	$\sum_{k=-\infty}^{\infty} 2\pi\delta(\omega + 2\pi k)$
4.	$a^n u[n]$ ( $ a  < 1$ )	$\frac{1}{1 - ae^{-j\omega}}$
5.	$a^{n-1} u[n-1]$ ( $ a  < 1$ )	$\frac{e^{-j\omega}}{1 - ae^{-j\omega}}$
6.	$u[n]$	$\frac{1}{1 - e^{j\omega}} + \sum_{k=-\infty}^{\infty} \pi\delta(\omega + 2\pi k)$

	Sequence, $x[n]$	z-Transform, $X[z]$	ROC
1.	$\delta[n]$	1	All $z$
2.	$u[n]$	$\frac{1}{1 - z^{-1}}$	$ z  > 1$
3.	$-u[-n-1]$	$\frac{1}{1 - z^{-1}}$	$ z  < 1$
4.	$a^n u[n]$	$\frac{1}{1 - az^{-1}}$	$ z  >  a $
5.	$-a^n u[-n-1]$	$\frac{1}{1 - az^{-1}}$	$ z  <  a $
6.	$a^{n-1} u[n-1]$	$\frac{z^{-1}}{1 - az^{-1}}$	$ z  >  a $
7.	$na^n u[n]$	$\frac{az^{-1}}{(1 - az^{-1})^2}$	$ z  >  a $
8.	$-na^n u[-n-1]$	$\frac{az^{-1}}{(1 - az^{-1})^2}$	$ z  <  a $
9.	$(\cos \omega_0 n) u[n]$	$\frac{1 - z^{-1} \cos \omega_0}{1 - 2z^{-1} \cos \omega_0 + z^{-2}}$	$ z  > 1$
10.	$(\sin \omega_0 n) u[n]$	$\frac{z^{-1} \sin \omega_0}{1 - 2z^{-1} \cos \omega_0 + z^{-2}}$	$ z  > 1$
11.	$(a^n \cos \omega_0 n) u[n]$	$\frac{1 - az^{-1} \cos \omega_0}{1 - 2az^{-1} \cos \omega_0 + a^2 z^{-2}}$	$ z  >  a $
12.	$(a^n \sin \omega_0 n) u[n]$	$\frac{az^{-1} \sin \omega_0}{1 - 2az^{-1} \cos \omega_0 + a^2 z^{-2}}$	$ z  >  a $



# THE UNIVERSITY OF ZAMBIA

SCHOOL OF ENGINEERING

DEPARTMENT OF ELECTRICAL AND ELECTRONIC ENGINEERING

UNIVERSITY EXAMINATIONS

EXAMINATIONS FOR 2021 ACADEMIC YEAR  
TUESDAY 7<sup>TH</sup> DECEMBER 2021

TIME: 14.00 - 17.00 HRS

## EEE 4571 - ELECTRONIC ENGINEERING II

---

DURATION	: THREE (3) HOURS
INSTRUCTIONS	: ANSWER FIVE (5) QUESTIONS
ADDITIONAL INFORMATION	: Useful constants and variables are listed at the end of this question paper

---

### Question 1.

When doping a semiconductor material, both acceptor and donor impurities may be added until the desired doping composition in a semiconductor is obtained.

- a. Since both types of charge carriers are present in the same semiconductor material, calculate the charge concentrations per cubic metre in a silicon semiconductor doped with the following impurities stating the type of semiconductor obtained (Assume room temperature and that all impurity atoms are ionised. Also note that  $N_d$  and  $N_a$  denote donor and acceptor impurity atoms concentrations respectively):
  - (i)  $N_d = 10^{20} \text{ cm}^{-3}$  and  $N_a = 10 \text{ cm}^{-3}$ . (4 marks)
  - (ii)  $N_d = 10 \text{ cm}^{-3}$  and  $N_a = 10^{10} \text{ cm}^{-3}$ . (4 marks)
  - (iii)  $N_d = 0$  and  $N_a = 0$ . (4 marks)
- b. Using a specific donor or acceptor atom, demonstrate how intrinsic:
  - (i) Germanium semiconductor is doped n-type. (1 marks)
  - (ii) Gallium arsenide semiconductor is doped n-type. (3 marks)
  - (iii) Germanium semiconductor is doped p-type. (1 marks)
  - (iv) Gallium arsenide semiconductor is doped p-type. (3 marks)

### Question 2.

- a. The fabrication of modern bipolar junction transistors (BJTs) employs the planar epitaxial process in which a BJT device layers are formed through growth of single-crystal films on the surface of a silicon wafer resulting in a structure shown figure 1. Contacts for connecting the BJT to the external circuit are then fused onto the active region through metallisation.

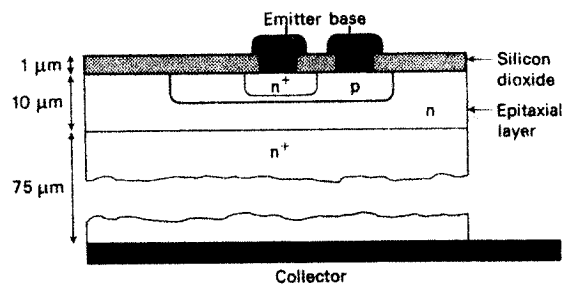

Figure 1. A sectional view of an  $n^+$ -p-n BJT

- i. Describe the functions of the  $n^+$  region on the emitter side,  $n^+$  region on the collector side, and that of the silicon dioxide layer. (3 marks)
  - ii. If the metal used for emitter, base and collector contacts is aluminium, use appropriate diagrams to describe the different types of contacts formed between aluminium and doped. (6 marks)
  - iii. Explain why the emitter region is always doped more heavily than the collector region. (3 marks)
- b. An ideal common emitter  $n^+$ -p-n BJT with a current gain of 95 is operated on a base current of  $20 \mu\text{A}$ . If the recombination time of charge carriers in the base is  $1 \mu\text{s}$ :
    - i. Calculate the emitter current. (3 marks)
    - ii. Determine the time taken by minority carriers to cross the base region. (3 marks)
    - iii. Find the volume of excess minority charge in the base. (2 marks)

### Question 3.

- a. When a moderate external electric field is applied to a semiconductor crystal, its electrons experience a force in the direction of the positive terminal. Alternatively, if there is a spatial difference in electron density, electrons in the semiconductor crystal move in an effort to evenly distribute themselves.
- (i) Name the type of electron current arising from the application of an external electric field to a semiconductor and thus derive an expression for the velocity and mobility of the moving electrons as a function of the applied electric field, clearly stating the unit(s) of measurement. **(4 marks)**
  - (ii) Name the type of electron current arising from the difference in the spatial electron density and state the expression (or law) for the electron flux as a function of electron spatial concentration gradient, clearly stating the unit(s) of measurement. **(4 marks)**
  - (iii) State the mathematical expression (or equation) that relates the electron current derived in (i) to the electron current derived in (ii), clearly defining all the terms in the expression. **(3 marks)**
- b. If an external electric field of 1000 V/m is applied to an n-type silicon semiconductor at room temperature, it produces a majority carrier drift velocity of  $2.0 \times 10^4$  cm/s:
- (i) Calculate the mobility of majority charge carriers. **(3 marks)**
  - (ii) Compute the diffusivity of the majority charge carriers. **(3 marks)**
  - (iii) Name any three factors that affect the mobility of charge carriers and to considered during the doping process/operation of the resulting power electronics device. **(3 marks)**

### Question 4.

- a. Junction-gate field effect transistors (JFET's) are a special class of transistors in power engineering electronics:
- (i) Using appropriate diagram(s) sketch the construction of an n-channel JFET. **(5 marks)**
  - (ii) Explain the operation of the JFET sketched in (i) and hence derive the general current-voltage output characteristics. **(5 marks)**
  - (iii) Derive expressions for the channel width, drain current and applied gate voltage for a JFET. **(5 marks)**
- b. A JFET is fabricated by diffusing two p+ gate regions against a  $0.02 \Omega\text{m}$  n-type silicon region channel whose doping density is  $2 \times 10^{21} \text{m}^{-3}$ . If the gate is  $50 \mu\text{m}$  long and  $40 \mu\text{m}$  wide and the zero bias channel width of the n-type silicon region is  $5 \mu\text{m}$ , calculate the bias voltage to be applied to the gate so as to obtain a channel resistance of  $10 \Omega$ . **(5 marks)**

### Question 5.

- a. In a semiconductor material, electrons may exist either as Fermi-Dirac electrons or Maxwell Boltzmann electrons and thus being in a state of either taking part or not taking part in electrical/electronic conduction process:
- State any two conditions upon which to distinguish a Fermi-Dirac electron from Maxwell Boltzmann electron. *(4 marks)*
  - Using appropriate condition(s), diagram(s) and equation(s), describe the properties for an electron that obeys Fermi-Dirac statistics. *(4 marks)*
  - Using appropriate condition(s), diagram(s) and equation(s), describe the properties for an electron that obeys Maxwell-Boltzmann statistics. *(4 marks)*
- b. For a pure silicon semiconductor crystal at room temperature:
- Determine the chance of an electron being in the conduction band. *(4 marks)*
  - Calculate the chance of a hole appearing in the valence band. *(4 marks)*

### Question 6.

- a. Germanium is semiconductor that is used in fabricating distinct photodiodes and infrared detectors.
- Define the quantum numbers that completely describe the electronic structure of a germanium atom. *(4 marks)*
  - Using appropriate diagram(s), describe the formation of energy bands in a germanium crystal composed of X number of atoms. *(9 marks)*
  - Using your energy bands formation concept developed in (ii) above, classify the energy bands for copper, silicon and silicon dioxide at room temperature. *(3 marks)*
- b. Determine the wavelength and frequency of a photon that is able to just excite an electron from the valence band to the conduction band in a germanium semiconductor:
- At room temperature. *(2 marks)*
  - At absolute temperature. *(2 marks)*

### Question 7.

- a. The process of adding of impurity atoms into a lattice of a pure semiconductor is called doping.
- Describe any two methods for doping a semiconductor, clearly illustrating the concentration of impurity atoms as a function of semiconductor material depth. *(6 marks)*
  - Using suitable diagrams discuss any two mechanisms through which dopant atoms occupy sites in the lattice of a host semiconductor material. *(5 marks)*
- b. Boron decomposed from the gas diborane ( $B_2H_3$ ) is a common dopant for doping silicon. To enable the boron atoms to diffuse into the silicon semiconductor lattice the temperature in a doping chamber is maintained at 1000 °C, the concentration of  $B_2H_3$  gas on the silicon wafer surface is  $10^{20} \text{ cm}^{-3}$  and the time for completing the doping process is 60 minutes. Given that a mathematical expression for the total number of dopant atoms per unit area  $Q(t)$  in the doped silicon semiconductor wafer is  $Q(t) = 1.13C_s\sqrt{Dt}$ , where  $C_s$  is the concentration of dopant atoms at the surface of the silicon wafer, D is the impurity

diffusion coefficient and  $t$  the exposure time of silicon semiconductor in the doping chamber in seconds:

- i. Deduce the type of doping attained and type of majority charge carriers in the final doped silicon semiconductor. (3 marks)
- ii. Calculate the diffusion length of boron atoms in the silicon semiconductor. (3 marks)
- iii. Find the total number of boron atoms per unit area in the doped silicon semiconductor. (3 marks)

**LIST OF SOME USEFUL CONSTANTS AND VARIABLES**

1. Boltzmann constant  $= 1.38 \times 10^{-23} \text{ JK}^{-1}$
2. Electronic charge  $= 1.602 \times 10^{-19} \text{ C}$
3. Mass of electron  $= 9.109 \times 10^{-31} \text{ kg}$
4. 1 electron volt  $= 1.602 \times 10^{-19} \text{ J}$
5. Room temperature  $= 27^\circ \text{ C}$
6. Silicon intrinsic carrier concentration  $= 1.5 \times 10^{16} \text{ m}^{-3}$  at room temperature
7. Germanium intrinsic carrier concentration  $= 2.0 \times 10^{19} \text{ m}^{-3}$  at room temperature
8. Silicon band gap  $= 1.12 \text{ eV}$  at room temperature &  $1.17 \text{ eV}$  at 0K
9. Germanium band gap  $= 0.67 \text{ eV}$  at room temperature &  $0.75 \text{ eV}$  at 0K
10. Gallium arsenide band gap  $= 1.43 \text{ eV}$  at room temperature &  $1.52 \text{ eV}$  at 0K
11. Absolute temperature  $= -273^\circ \text{ C}$
12. Planck's constant  $= 6.63 \times 10^{-34} \text{ J.s}$
13. Germanium atom atomic number  $= 32$
14. Silicon atomic number  $= 14$
15. Speed of light  $= 3.0 \times 10^8 \text{ m/s}$
16. Boron diffusion coefficient at  $1000^\circ \text{ C} = 2 \times 10^{-14} \text{ cm}^2 / \text{s}$
17. Electron mobility in silicon  $= 1300 \text{ cm}^2 / \text{V.s}$
18. Hole mobility in silicon  $= 500 \text{ cm}^2 / \text{V.s}$
19. Assume room temperature if not specified

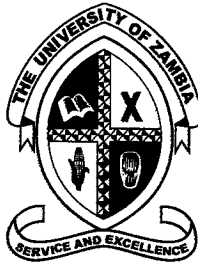

# THE UNIVERSITY OF ZAMBIA

## SCHOOL OF ENGINEERING

### UNIVERSITY EXAMINATIONS

## Communication Principles-EEE 4682

<b>TIME</b>	: Three (3) hours
<b>INSTRUCTIONS</b>	: 1. Question one in Section A is compulsory 2. Answer any other <b>Four (4)</b> questions from section B.
<b>ADDITIONAL INFORMATION</b>	: 3. Scientific calculators are allowed

---

## Section A

---

### Question One

- a) Explain how standing waves are generated in a transmission line. *[2 Marks]*
- b) As an engineer working for a public telephone land line network company. Your task involves among others supervising a total of six technicians. Your chief technician has informed you that the load impedance at the customer's premises is 65 ohms, fifteen ohms more than the characteristic impedance of the line. Ascertain the values of :
- i. Voltage reflection coefficient. *[3 Marks]*
  - ii. The voltage standing wave ratio. *[2 Marks]*
  - iii. The minimum impedance of the line. *[3 Marks]*
  - iv. The return power loss in decibels. *[2 Marks]*
  - v. The value of the resistance needed to avert standing waves. *[2 Marks]*
- c) With the aid of a diagram, state how you would mitigate the effects of standing waves in a transmission line. *[2 Marks]*
- d) A particular cable has a capacitance of 40pF per meter and a characteristic impedance of 70 ohms.
- i. What is the inductance per meter of this cable? *[2 Marks]*
  - ii. Determine the impedance of an infinity long section of such a cable. *[2 Marks]*
- 

## Section B

---

### Question Two

- a) With the aid suitable illustrations, explain how sky wave propagation is achieved stating the role of ionosphere layers. *[4 Marks]*
- b) A signal is launched at an angle of 60 degree from the earth into the ionosphere; from Mwembeshi satellite to the receiving satellite in Pretoria. If the distance between the two earth satellites is 10000 km and the angle of incidence is equal to the angle of reflection in the F-Layer. Determine:
- i. The angle of reflection. *[2 Marks]*
  - ii. The maximum height that the signal has been propagated before returning to earth. *[3 Marks]*
  - iii. The maximum usable frequency if the critical frequency is 50MHz. *[3 Marks]*
- c) Imagine you are a transmission engineer for ZTM Ltd, one of the largest telecommunication company, headquartered in the Republic of Makalanguzu. The company provides landline and mobile telecommunication services to its clients. Due to growing demands for its services, it has become necessary to erect another microwave receiving tower 60km on the northern part of Makalanguzu. If the height of the transmission antenna at the headquarters is 25m, calculate the appropriate height of the antenna at the receiver, assuming negligible path losses and fading margin. *[4 Marks]*

- d) Calculate the path loss using the Hata model, in an urban environment, given that the transmit frequency is 900MHz, if the distance between the transmitter and receiver is 30km. The height of the transmitter antenna is 30m while that of the mobile receiver is 1.5m. *[4 Marks]*

**Question Three**

- a) Contrast between Narrowband and wide band FM. *[4 Marks]*  
b) Explain why a pre-emphasis circuit is added in FM transmitters. *[2 Marks]*  
c) Contrast between FM and AM transmission. *[4 Marks]*  
d) A 4 kHz audio tone is used to modulate a 50MHz carrier causing a frequency deviation of 20 kHz. If the significant number of side bands are 4, determine:  
i. The carrier swing. *[2 Marks]*  
ii. The modulation index. *[4 Marks]*  
iii. The bandwidth of the FM signal. *[4 Marks]*

**Question Four**

- a) Explain why modulation is needed in communications systems. *[2 Marks]*  
b) With the aid of a block diagram explain how Amplitude Modulation (AM) transmission is achieved. *[4 Marks]*  
c) Show that AM signal consists of carrier and two sidebands. *[4 Marks]*  
d) A SSB transmission contains 10,000 watts. This transmission is to be replaced by a standard amplitude modulated signal with the same power content. For the percentage modulation of 70%, determine:  
i. The power content of the carrier. *[3 Marks]*  
ii. The power content of and each of the sidebands. *[4 Marks]*  
iii. Calculate the power saving if one sideband and carrier are suppressed. *[3 Marks]*

**Question Five**

- a) Explain the terms 'simplex', 'half duplex' and 'full duplex' as applied to communications systems. *[3 Marks]*  
b) Briefly explain three factors that determine thermal noise levels in communication systems. *[3 Marks]*  
c) Given a receiver with an effective noise temperature of 30 degrees Celsius and a 12MHz bandwidth. If the effective resistance of the receiver is 200 ohms, calculate:  
i. The noise power. *[3 Marks]*  
ii. The noise voltage. *[3 Marks]*  
d) A noise free channel has a bandwidth of 6GHz.  
i. If the voltage levels are 15, calculate the channel capacity. *[4 Marks]*  
ii. Suppose the channel capacity and bandwidth remains the same but the channel experiences some noise. Calculate the signal to noise ratio in decibels. *[4 Marks]*

**Question Six**

- a) State one advantage of QPSK and one disadvantage over analogue phase modulation.

- [2 marks]*
- b) With the aid of suitable diagrams, describe how the following modulation techniques are achieved:
- i. Pulse amplitude modulation. *[4 marks]*
  - ii. Pulse width modulation. *[4 marks]*
- c) A 75MHz carrier having amplitude of 50V is Amplitude modulated by a 3 kHz audio having amplitude of 15V.
- i. Sketch the audio signal. *[1.5 Marks]*
  - ii. Sketch the carrier signal. *[1.5 Marks]*
  - iii. Construct the modulated wave. *[1.5 Marks]*
  - iv. Determine the modulation factor and percentage modulation. *[1.5 Marks]*
  - v. What frequencies would show up in the spectrum analysis of the modulated wave? *[2 Marks]*
  - vi. Write the trigonometric equations for the carrier and modulating waves. *[2 Marks]*

### Question Seven

- a) With the aid of a suitable diagram, explain how FSK is achieved. *[4 Marks]*
- b) State one major advantage and disadvantage of FSK over ASK. *[2 Marks]*
- c) Sketch the equivalent circuits of a both the lossy and lossless transmission lines. *[4 Marks]*
- d) Mwanamubotu Communication Ltd has just been contracted to install satellite dishes for all Multichoice Zambia ltd customers. A bunch of coaxial cables are to be connected between the LNB located at the centre of the dishes and the decoders inside the houses. If the inside diameter of the outer conductor is 3.2mm and the outside diameter of inner conductor is 0.50mm; and if the relative permittivity of insulation between the two conductors is 2.3, Calculate:
  - i. The characteristic impedance of the cable. *[5 Marks]*
  - ii. The velocity factor. *[5 Marks]*

*End*

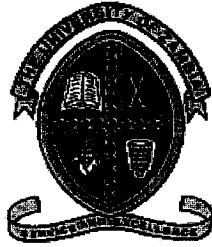

**THE UNIVERSITY OF ZAMBIA**

**SCHOOL OF ENGINEERING**

**DEPARTMENT OF GEOMATIC ENGINEERING**

**2020/2021 ACADEMIC YEAR**

**Final Examination**

**COURSE NAME: Principles of Geomatics**

**COURSE CODE: GEE 4812**

**TIME: Three (3) HOURS**

**TOTAL MARKS: 100**

**DATE: 18<sup>th</sup> November, 2021.**

**INSTRUCTIONS:**

- 
- 1. Answer all Five (5) questions**
  - 2. This Exam is Closed Book**
  - 3. Calculators are permitted**
  - 4. No communication between candidates**
  - 5. Show YOUR work leading to the solution**
  - 6. Marks are shown in brackets**

**NB: There are Four (4) pages in this paper.**

**QUESTION ONE [9+4+4+3] Marks**

- a) Being a newly employed graduate Engineer working for a Mining firm, you were tasked to advise the company on the appropriate equipment to employ in carrying out a volumetric analysis of a mine damp site. Between a Differential GPS and a Drone, which one would you recommend? Briefly explain. **[9 marks]**
- b) State the major difference between a Total Station and a Theodolite **[4 marks]**
- c) Define **[4 marks]**
  - i. Geographic Information System (GIS)
  - ii. Geomatic Engineering
- d) What is Map projection? **[3 marks]**

**QUESTION TWO [10+10] Marks**

- a) Given the data in the table below, calculate the *simple mean* and *reduced mean* values for the horizontal angles. **[10 marks]**

Stn	Obj	Face left			Face Right			Simple mean			Reduced mean		
		°	'	"	°	'	"	°	'	"	°	'	"
X	P	0	20		180	20							
	Z	62	38		242	38							
	R	109	52		289	52							
	T	268	14		88	15							
	P	0	21		180	20							

- b) A 30-m steel tape was standardised at a temperature of 20°C and under a pull of 10kg. The tape was used in catenary to fix a distance of 28m between two points at 40°C and under a pull of 5kg. Given that the cross-sectional area of the tape =  $0.02\text{cm}^2$ , total weight 470g, Young’s modulus of steel =  $2.1 \times 10^6 \frac{\text{kg}}{\text{cm}^2}$ , and coefficient of linear expansion =  $11 \times 10^{-6}\text{per } ^\circ\text{C}$ .

Find the correct distance between the two points

**[10 marks]**

### QUESTION THREE [4+12+4] Marks

- c) State the difference between *static* and *real time kinematics* mode of surveying with a Differential GPS. [4 marks]
- d) Agriculture Engineering students were tasked with the laying out of a water line from the Goma lakes to their new green house structure. They then decided to collaborate with the rest of the 4<sup>th</sup> year B.Eng. students and share ideas on how best they could execute this task. They finally carried out a precise levelling with a digital level machine to determine the elevations of the proposed route for the subsequent slope design. The following readings were obtained at intervals of 20m.
- 2.375, 1.730, 0.615, 3.450, 2.835, 2.070, 1.835, 0.985, 0.435, 1.630, 2.255 and 3.630 m. Meanwhile the instrument was shifted after the 4<sup>th</sup> (fourth) and 8<sup>th</sup> (eighth) readings. The last reading taken on a BM of RL 110.200m. Find the RLs of all points. [12 marks]
- e) Remote Sensing and GIS usually leads to geoprocessing tasks such as georeferencing. What do you understand by the term Georeferencing? [4 marks]

### QUESTION FOUR [10+10] Marks

- a) During an industrial attachment, a fourth year Civil Engineering student in the absence of a Geomatic Engineer was tasked to determine the following:
- i. The distance between the newly established control points LP1 and LP2. [2 marks]
  - ii. The bearing of point LP2 from point LP1 [3 marks]
  - iii. The coordinates of point TLP3 located 50m from point LP1 at a bearing of 65 degrees [3 marks]

#### Data

Point ID	Eastings (m)	Northings (m)
LP1	642965.329	8297842.982
LP2	642961.260	8297872.011

- iv. Name the exercise in (i & ii) and (iii) above [2 marks]
- b) Name the five (5) fields or disciplines of Geomatic Engineering and briefly discuss each of them? [10 marks]

**QUESTION FIVE [3+8+5+4] Marks**

- a) Name three (3) major elements of a GIS system [3 marks]
- b) What do you understand by the following terms
  - i. Spatial data [4 marks]
  - ii. Precision [4 marks]
- c) Calculate the side widths ( $W_i$ ) and cross-sectional area of an embankment in the figure below having the following dimensions: [5 marks]

Road width = 20m  
 Side Slopes = 1 in 2  
 Existing ground slope = 1 in 10  
 Centre height = 10 m

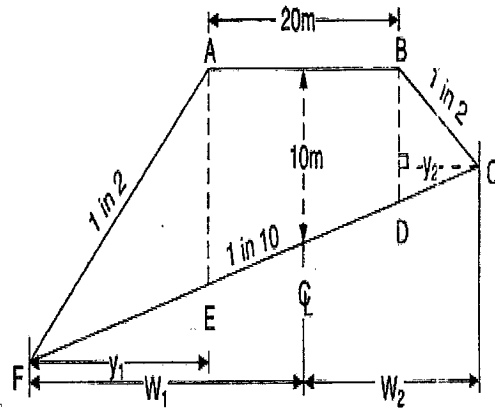

- d) List the three (3) feature classes found in GIS [3 marks]

*End of the Exam, good luck!*

## Useful equations

$$C_t = \alpha (T_m - T_0)L$$

$$C_s = \Delta H_{AB}^2 / 2l_m$$

$$C_p = \frac{(P_m - P_o)L}{AE}$$

$$C_{std} = \frac{l_m(l - l_n)}{l_n}$$

$$C_s = \frac{L(W)^2}{24P_m^2}$$

**THE UNIVERSITY OF ZAMBIA**  
**SCHOOL OF ENGINEERING**  
**DEPARTMENT OF MECHANICAL ENGINEERING**

**2021 ACADEMIC YEAR**

**END OF YEAR EXAMINATION**

**MEC 2009 – ENGINEERING DRAWING I**

**TIME ALLOWED:** FOUR (4) HOURS

**CLOSED BOOK EXAMINATION:** TEXT BOOKS AND MARKED TUTORIAL SHEETS  
ARE NOT ALLOWED

**INSTRUCTIONS**

---

1. Answer a total of **FOUR (4)** questions.
  - a. SECTION A: Question **ONE (1)** is compulsory.
  - b. SECTION B: Answer any **TWO (2)** questions from this section.
  - c. SECTION C: Answer any **ONE (1)** question from this section.
2. **ONLY** question **ONE (1)** should be drawn on the drawing paper face which will bear the **Title Block**. **SECTION B** should be answered **ON THE REVERSE SIDE** of the same drawing sheet.
3. **SECTION C** should be answered on a **SEPARATE DRAWING ANSWER SHEET**. Indicate **ONLY** your **Computer Number** on this drawing sheet.
4. Clearly label answered questions.
5. Indicate only your computer number in the title block and on all other drawing sheets used. **DO NOT INDICATE YOUR NAME ON ANY ANSWER SHEET.**
6. Construction lines should not be erased and should be clearly visible.
7. Do not dimension your work unless otherwise stated.
8. Marks will be awarded for: correct Solution, Neatness, Layout and Good Line Work.
9. All dimensions in millimeters.



**SECTION B**

Answer ANY TWO (2) Questions

Total Marks [30 Marks]

- Q2. Figure Q2 shows the profile of a Gearbox Cover Plate. Using geometrical constructions, construct the given profile to a scale of 1:2. DO NOT DIMENSION. [15 Marks]

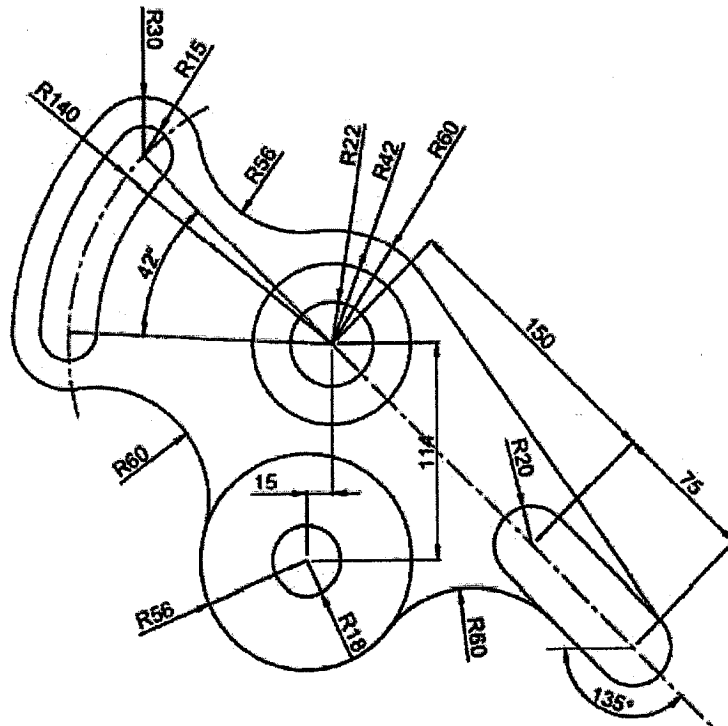

Figure Q2

- Q3. In the mechanism shown in Figure Q3, the 40mm diameter rotating disk drives the connecting link AB which in turn is connected at B to link CD which itself is hinged at C. End D is further joined to a connecting rod DE which is hinged to the piston pump at E. Trace the locus of point P located at a distance in the current position as shown in the figure. Show also in one selected position, the linkage representing this mechanism using standard graphical components.

(Note that in the initial position of the mechanism, point P along AB will coincide with the horizontal axis of the centre of the rotating disk and the connecting rod DE will be in its horizontal position.) [15 Marks]

## SECTION C – ELECTRICAL COMPONENT

Total Marks: 30 Marks

### INSTRUCTIONS

1. Answer any **ONE (1) Question from this section.**
  2. Make sure you draw correct component symbols while following the **DIMENSIONS.**
  3. Full marks will be awarded to **CORRECTLY** drawn **WORKING** circuits.
  4. **NO TITLE BLOCK REQUIRED** (NEATLY indicate only your **COMPUTER NUMBER** at the bottom right corner of the drawing paper).
  5. **FOR ADDITIONAL INFORMATION:** Use Appendix A.
- 

### Question 5

Mathematically, sinusoidal waveforms can be sketched based on these three respective expressions  $A_{R(t)} = A_m \sin(\omega t + 0^\circ)$ ,  $A_{Y(t)} = A_m \sin(\omega t - 120^\circ)$ , and  $A_{B(t)} = A_m \sin(\omega t - 240^\circ)$  by bearing in mind their magnitude and various phase shifts. These actually happen to be the waveforms in the **RED**, **YELLOW** and **BLUE** phases respectively as pictured in the three-phase transmission of electrical power by ZESCO. Now, use your drawing instruments to draw these waveforms on the same axes for two revolutions.

**Hint:** Use a circle of a rotating phasor (diameter = 50 mm) as a reference guide and 10 mm to represent  $30^\circ$  on the x-axis of your graph.

[30 Marks]

### Question 6

Zambia Sugar Company intends to install an Induction motor for heavy-duty centrifugal water pump to pump water from the Kafue River for irrigation as well as other uses. As the Engineer who has been sub-contracted to do the job, you are required to **Design** and **draw** the power and control circuits to fulfil the required operating conditions using only appropriate materials from the list below:

#### **Operating conditions;**

- i. Pressing the start push button should cause the motor (M) to start running.
- ii. Tripping the overload relay (O/L) or pressing the stop push button ( $S_1$ ) should bring the whole operation to a halt instantaneously.

#### **Materials;**

- i. 1 x Overload relays
- ii. 1 x Start push button
- iii. 1 x Stop push button
- iv. 1 x 6600 V, 50 Hz, 3-phase squirrel cage Induction motor
- v. 1 x On delay timer, with a NO (normally open) contact
- vi. 1 x 6600 V, 50 Hz contactor with 2 NO contacts each

[30 Marks]

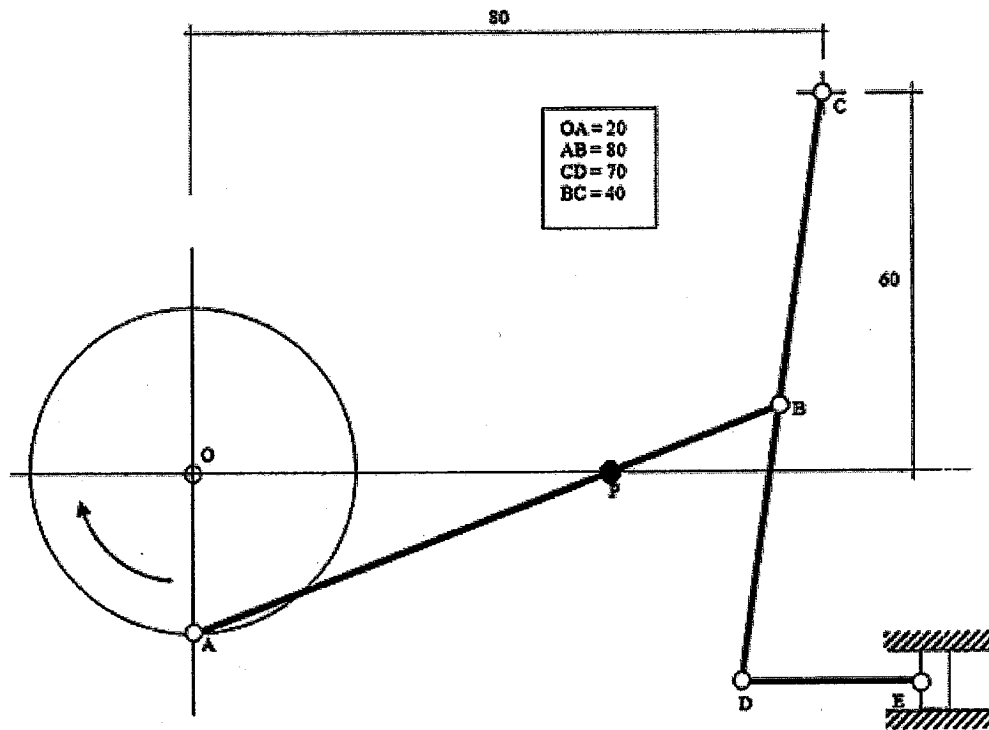

Figure Q3

Q4 A solid hexagonal pyramid, base 90mm across flats with 100mm vertical height. It is cut as shown in Figure Q4, with base lying at an angle of  $45^\circ$  to the horizontal plane.

Draw in 1<sup>st</sup> angle of projection, scale 1:1, the following:

- The **FRONT ELEVATION**,
- Project a **PLAN**
- Project a **LEFT END** view showing all hidden details.

[15 Marks]

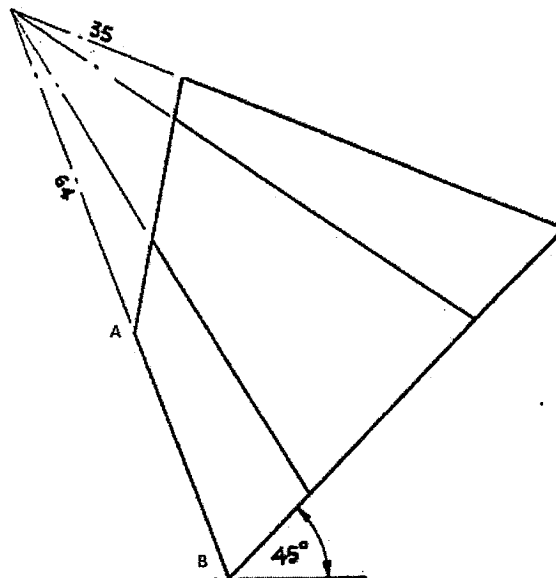
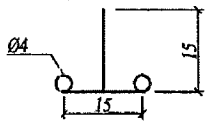

Figure Q4

## APPENDIX A: Dimensions for Commonly Used Symbols



PRESSURE SWITCH  
NORMALLY CLOSED  
PRESS TO BREAK



DC MOTOR

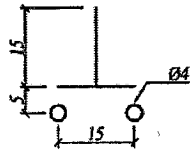

PRESSURE SWITCH  
NORMALLY OPEN  
PRESS TO MAKE

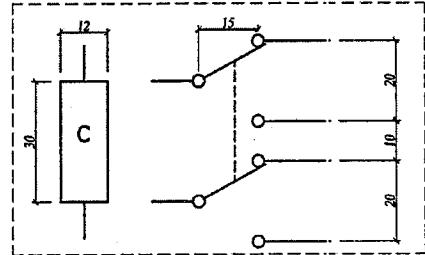

RELAY WITH 2-POLE CHANGE OVER SWITCH

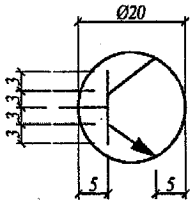

TRANSISTOR

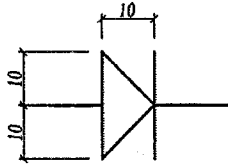

DIODE

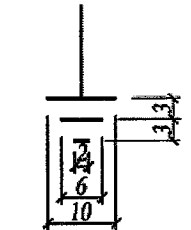

GROUND OR  
EARTH

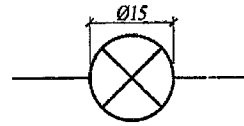

INDICATOR  
LAMP

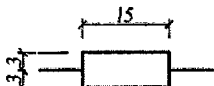

RESISTOR

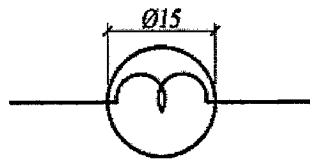

LIGHT LAMP

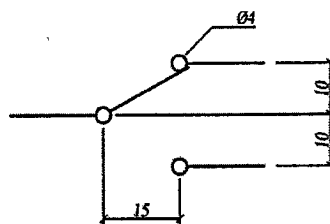

SWITCH 2



BATTERY

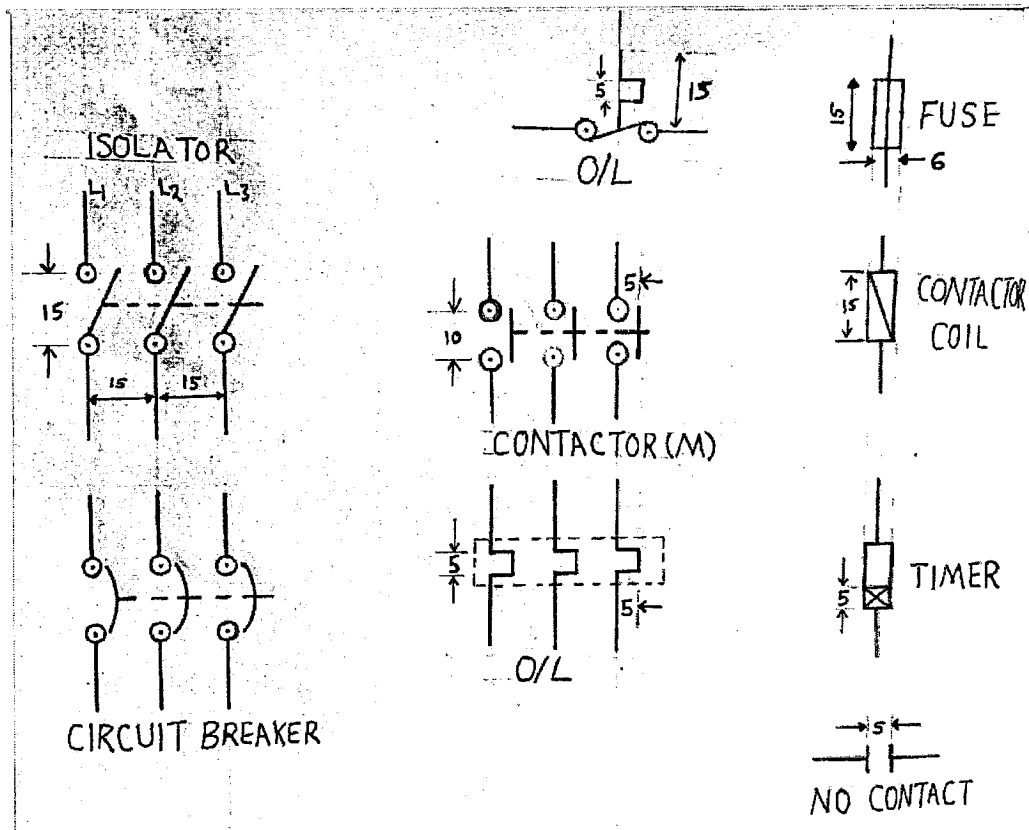



THE UNIVERSITY OF ZAMBIA  
SCHOOL OF ENGINEERING  
DEPARTMENT OF MECHANICAL ENGINEERING

UNIVERSITY EXAMINATIONS  
END OF YEAR EXAMINATIONS, 2020

MEC 2309 – PROPERTIES OF ENGINEERING MATERIALS I  
QUESTION PAPER

Read the following instructions carefully before you start writing:

- 
1. *This Examination is Closed Book.*
  2. *Time Allowed: Three (3) Hours.*
  3. *Answer a total of four (4) questions: Question 1 is compulsory and one other question from Section A and any two questions from Section B.*
  4. *Question 1 carries 40 marks. Other questions carry 20 marks each.*
- 

[DO NOT TURN THE PAGE OVER UNTIL YOU ARE TOLD TO DO SO]

## SECTION A: ANSWER QUESTION 1 AND ONE OTHER QUESTION

### Question One

#### This question is compulsory and carries 40 marks

Two hypothetical metals *C* and *D* are dissolved in each other and the following information is available from the experiment:

- The melting temperatures of *C* and *D* are 700 °C and 900°C, respectively.
  - The metals form a eutectic at a composition of 55% *D* at 400 °C
  - The maximum solubilities possible are found to be 20% of *D* in *C* and 25% of *C* in *D*.
  - At room temperature, maximum solubility of *D* in *C* is 5% and *C* in *D* is 10%
- a) Draw the phase diagram to scale and label the main features. All lines may be assumed to be straight. [20 marks]
- b) Describe the changes which would occur when a 60% *C* / 40% *D* alloy composition is allowed to cool slowly from the liquid state to room temperature. Mention the temperatures where the changes occur. [05 marks]
- c) For the 60% *C* / 40% *D* alloy, give the phases present, their relative proportions and their compositions at 500°C. [15 marks]

### Question Two

Assuming that metal atoms can be considered as hard spheres in contact, determine the coordination numbers and packing fractions for the following crystal structures:

- a) Body-centred cubic [06 marks]  
b) Face-centred cubic [07 marks]  
c) Hexagonal close-packed. [07 marks]

[Hints: Packing fraction = (volume of atoms in unit cell)/ (volume of unit cell) and the volume of a sphere is  $4\pi R^3/3$ .]

### Question Three

- a) Use the data in Table Q3 to determine which is denser between molybdenum and copper. [10 marks]
- b) Use a sketch to show that for the face-centred cubic (fcc) crystal structure the coordination number is 12. [05 marks]

- c). With a sketch, show that all atoms in the fcc crystal structure are lattice points. [05 marks]

Table Q3: Useful data for copper, iron and molybdenum

Element	Symbol	Structure	Atomic mass, $m_a$ (kg)	Lattice constant, $a$ (nm)
Copper	Cu	fcc	$1.05359 \times 10^{-25}$	0.36147
Iron	Fe	bcc	$9.26028 \times 10^{-26}$	0.28664
Molybdenum	Mg	bcc	$4.03720 \times 10^{-26}$	0.32094

#### Question Four

- a) Polymers are neither as strong or as stiff as metals, however they find wide use in engineering applications. Explain with suitable examples, four advantages of polymers in engineering applications. [08 marks]
- b) Name the three types of intermetallic compounds. Discuss how they are formed and mention some of their important properties. [12 marks]

### SECTION B: ANSWER A MINIMUM OF TWO QUESTIONS IN THIS SECTION

#### Question Five

Briefly discuss the following:

- a) Annealing [05 marks]  
b) Hardening [05 marks]  
c) Cyaniding [05 marks]  
d) Normalising [05 marks]

#### Question Six

- a)
- i) How is power lost in an electricity transmission line and how can this be minimised? [05 marks]
- ii) Discuss, with a specific example in each case, the cases where power loss in a conductor is desired and where it is not desired. [05 marks]

- b) Given a copper conductor 0.3mm diameter and 1.6m long, calculate the number of charge carriers. Assume that copper has a density of copper is  $8.93 \text{ Mg/m}^3$  and a valence of 1. The molecular mass of copper is 63.54 and Avogadro's Constant  $N = 6.023 \times 10^{23} [\text{mol}^{-1}]$
- [05 marks]**
- c) What would be the drift velocity in the wire under an applied voltage of 24 V? Take the conductivity of copper as  $\sigma = 5.98 \times 10^7 \text{ } \Omega^{-1} \text{m}^{-1}$  and the charge of an electron to be  $1.602 \times 10^{-19} \text{ C}$ .
- [05 marks]**

### **Question Seven**

- a) Using a well labelled stress-strain curve diagram, discuss the behaviour of ductile metallic materials when statically loaded in tension to the point of fracture.
- [10 marks]**
- b) During a tensile test, a specimen having a diameter of 13 mm was loaded up to a load of 80 kN and its diameter was measured as 11.8 mm. By showing your calculations, compare the true stress and strain with engineering stress and strain.
- [10 marks]**

---

**END OF MEC 2309 EXAMINATION  
G M MUNAKAAMPE /F K CHITALU  
DECEMBER 2021**

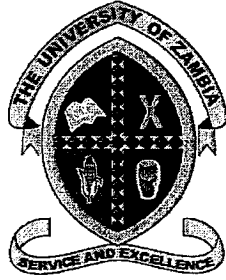

**THE UNIVERSITY OF ZAMBIA**  
**SCHOOL OF ENGINEERING**

**MEC3102 PRODUCTION ENGINEERING I, ELECTRICITY &  
ELECTRONICS II**

**2020/2021 ACADEMIC YEAR, TERM II**

**DECEMBER 2021**

**TERM EXAM**

**TIME: THREE HOURS.**

**CLOSED BOOK**

---

**INSTRUCTIONS**

1. Answer a total of **FIVE (5)** Questions.
  2. **Answer** not more than **Three (3)** Questions from **SECTION A** or **B**.
  3. All Questions carry **Equal Marks**, that is, **20 Marks** per Question.
  4. This Exam has **Eight (8)** pages including this cover.
  5. No external Materials are Allowed in the Exam.
  6. The Answer scripts should be bound/stapled separately, i.e., **SECTION A** and **SECTION B** separately.
-

## SECTION A

### QUESTION ONE

- (a) The orthogonal model can be used to approximate turning and certain other single-point machining operations so long as the feed in these operations is small relative to depth of cut. Thus, most of the cutting will take place in the direction of the feed, and cutting on the point of the tool will be negligible. Figure Q1 indicates the conversion from one cutting geometry to the other. The interpretation, however, of cutting conditions is different in the two cases. Identify the cutting conditions in each case and complete Table Q1 below.

[10 Marks]

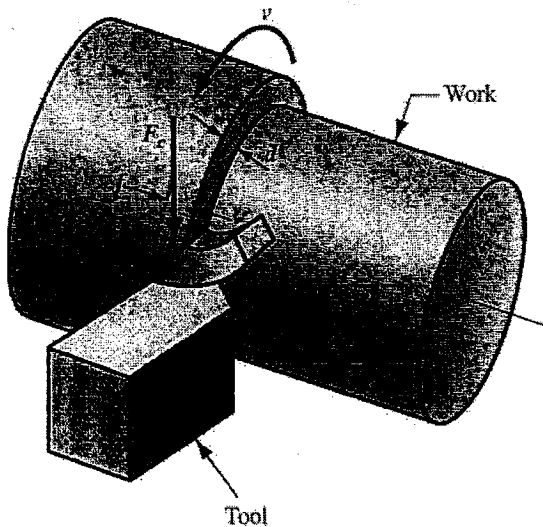

Figure Q1(a) Turning

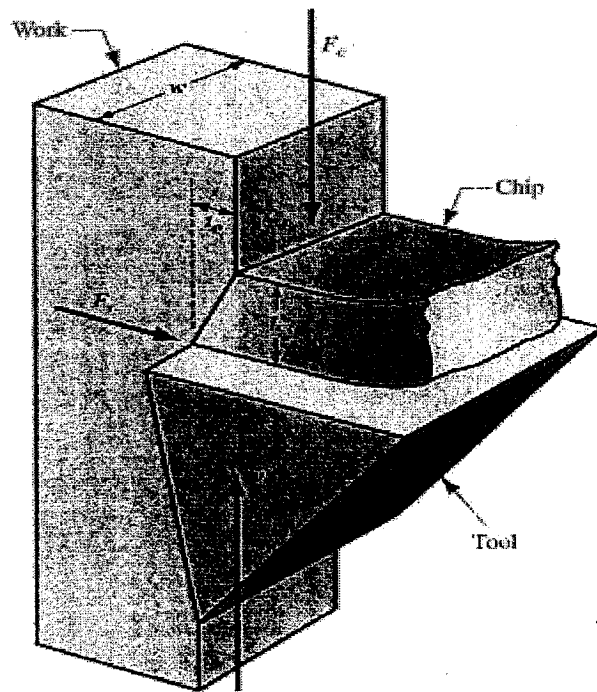

Figure Q1(b) Orthogonal Cutting Model

Table Q1: Conversion key: Turning operation vs. orthogonal cutting.

Turning operation	Orthogonal Cutting Model
$f =$	$t_0 =$
$d =$	$w =$
$v =$	$v =$
$F_c =$	$F_c =$
$F_f =$	$F_t =$

(b) Turning is performed on a work material with shear strength of 250 MPa. The following conditions are used:  $v = 3.0$  m/s,  $f = 0.20$  mm/rev,  $d = 3.0$  mm, and rake angle  $= 7^\circ$  in the direction of chip flow. The resulting chip ratio  $= 0.5$ . Using the orthogonal model as an approximation of turning, determine:

(i) The shear plane angle. [3 Marks]

(ii) The shear force. [3 Marks]

(iii) Cutting force and feed force. [4 Marks]

### QUESTION TWO

(a) Describe in words what the Merchant equation tells us [4 Marks]

(b) Determine Merchant's constant  $C$  for aluminium from the following information:

$\gamma = 35^\circ$ ,  $F_c = 200$  N;  $F_a = 90$  N;  $t_1 = 0.125$  mm;  $t_2 = 0.25$  mm; cutting speed  $= 30$  m/min;

width of cut  $= 2.5$  mm. [10 Marks]

(c) What amount of work per minute is done against friction at the chip-tool interface?

[6 Marks]

### QUESTION THREE

(a) A drilling operation is to be performed with a 12.7 mm diameter twist drill in a steel workpart. The hole is a blind hole at a depth of 60 mm and the point angle is  $118^\circ$ . The cutting speed is 25 m/min and the feed is 0.30 mm/rev. Determine

(i) The cutting time to complete the drilling operation, [5 Marks]

(ii) Metal removal rate during the operation, after the drill bit reaches full diameter.

[5 marks]

(b) A peripheral milling operation is performed on the top surface of a rectangular workpart, which is 300 mm, long by 100 mm wide. The milling cutter, which is 75 mm in diameter and has four teeth, overhangs the width of the part on both sides. Cutting conditions are:  $v = 80$  m/min,  $f = 0.2$  mm/tooth, and  $d = 7.0$  mm. Determine:

(i) The time to make one pass across the surface, [5 Marks]

(ii) The material removal rate during the cut.

[5 Marks]

**QUESTION FOUR**

(a) Name the three modes of tool failure in machining.

[3 Marks]

(b) What is meant by the parameter  $C$  in the Taylor tool life equation?

[3 Marks]

(c) Tool life tests in turning yield the following data: (1)  $v = 100$  m/min,  $T = 10$  min; (2)  $v = 75$  m/min,  $T = 30$  min.

(i) Determine the  $n$  and  $C$  values in the Taylor tool life equation.

[5 Marks]

(ii) Based on your equation; compute the tool life for a speed of 90 m/min,

[5 Marks]

(iii) The speed corresponding to a tool life of 20 min.

[4 Marks]



- (c) In the magnetic circuit detailed in Figure 6(a) with all dimensions in mm, calculate the required current to be passed in the coil having 200 turns in order to establish a flux of 1.28 mWb in the air gap and air gap length of 0.1 mm. Neglect fringing effect and leakage flux. The B-H curve of the material is given in Figure 6(b). Permeability of air may be taken as,  $\mu_0 = 4\pi \times 10^{-7}$  H/m. [10 Marks]

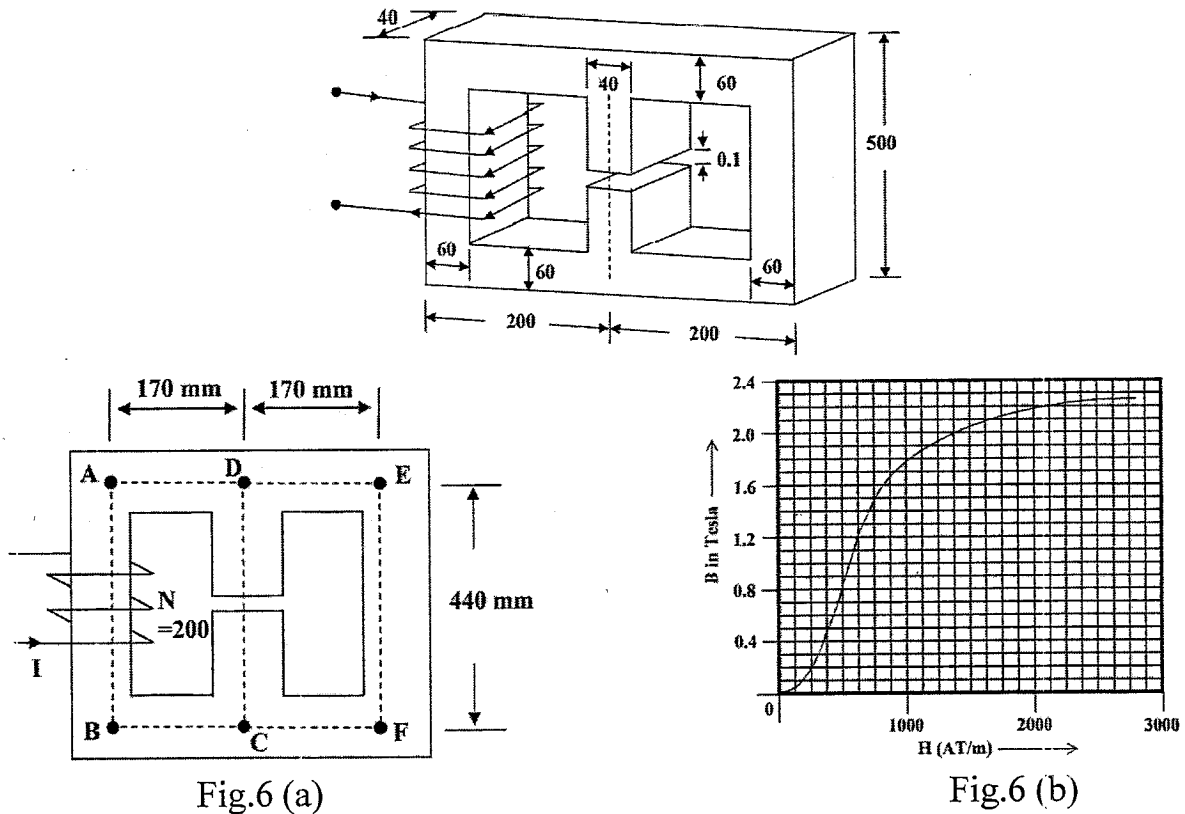

Fig.6 (a)

Fig.6 (b)

**Total Marks [20]**

**QUESTION SEVEN**

- (a) A three-phase delta-connected load, each phase of which has an inductive reactance of 40  $\Omega$  and a resistance of 25  $\Omega$ , is fed from the secondary of a three-phase star-connected transformer, which has a phase voltage of 230 V.

- i. Draw the circuit diagram of the system [1 Mark]

Calculate:

- ii. The current in each phase of the load; [2 Marks]  
 iii. The p.d. across each phase of the load; [2 Marks]  
 iv. The current in the transformer secondary windings; [2 Marks]  
 v. The total active power taken from the supply and its power factor. [2 Marks]

- (b) The following resistance values of a platinum resistance thermometer were measured at a range of temperatures. Determine the measurement sensitivity of the instrument in ohms/ $^{\circ}$ C.

[4 Marks]

Resistance ( $\Omega$ )	Temperature ( $^{\circ}\text{C}$ )
307	200
314	230
321	260
328	290

(c) For the circuit shown in figure 7.1(c)

- i. Determine the relationship between the output  $Z$  and the three inputs  $A$ ,  $B$  and  $C$ .

[3 Marks]

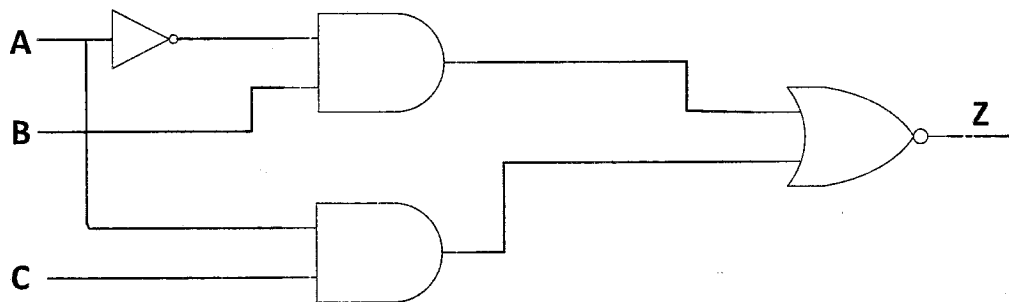

- ii. Construct a truth table for the function.

[4 Marks]

Total marks [20]

### QUESTION EIGHT

- (a) Using the Karnaugh map shown in figure 8.1(a), obtain a simplified min-term logic expression.

[6 Marks]

AB \ CD				
	1	0	1	0
	0	0	1	1
	0	0	0	0
	1	1	1	0

Fig. 8.1(a)

- (b) The gate network shown in figure 8.2(b) has three inputs:  $A$ ,  $B$  and  $C$ .

Determine the expression for the output  $Z$  and simplify the expression.

[6 Marks]

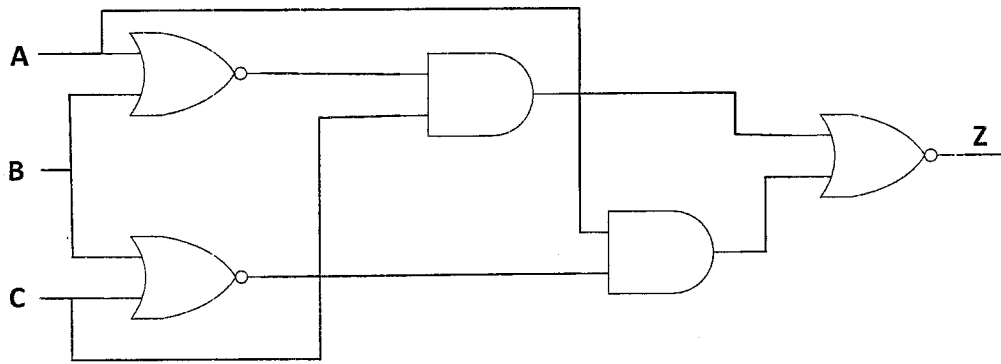

Fig. 8.2(b)

(c) The load taken by a three-phase induction motor is measured by the two-wattmeter method, and the readings are 860 W and 240 W. Determine:

- i. The total active power taken by the motor. [2 Marks]
- ii. The power factor at which the motor is working at. [2 Marks]

(d) For the moving coil instrument shown in figure 8.1(d), derive the deflection torque equation and comment on the shape of the scale. [4 Marks]

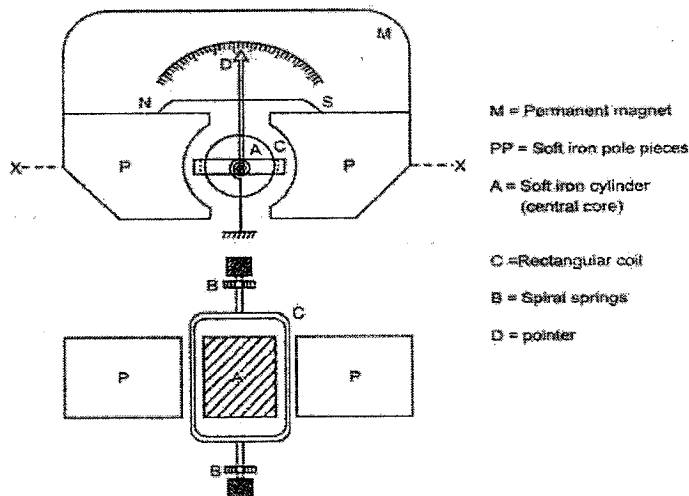
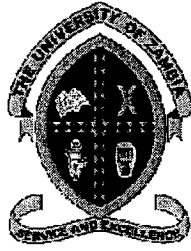

Fig. 8.3(c)

Total marks [20]

-----

**END OF EXAMINATION**



THE UNIVERSITY OF ZAMBIA  
SCHOOL OF ENGINEERING  
DEPARTMENT OF MECHANICAL ENGINEERING

UNIVERSITY EXAMINATIONS

FINAL EXAMINATIONS, 2020/2021

NOVEMBER/DECEMBER 2021

MEC 3352 – STRENGTH OF MATERIALS II

**QUESTION PAPER**

Read the following instructions carefully before you start writing:

---

1. *This examination is 'Closed Book'.*
  2. *Time allowed is three (3) hours.*
  3. *Answer any five (5) Questions*
  4. *All questions carry 20 marks each.*
  5. *This question paper has three (4) printed pages including this cover page.*
- 

[DO NOT TURN THE PAGE OVER UNTIL YOU ARE TOLD TO DO SO.]

Q1.

- (a) From first principles, derive the relationships for hoop and radial stresses at any radius  $r$  for a thick spherical shell of inner and outer radii  $r_1$  and  $r_2$ , respectively, under internal pressure  $p_1$  and external pressure  $p_2$ . Young's modulus and Poisson's ratio are  $E$  and  $\nu$ , respectively. [15 marks]
- (b) A thick spherical shell of 180 mm internal diameter is subjected to an internal fluid pressure of 24 MPa. If the permissible tensile stress is 120 MPa, find the thickness of the shell. [10 marks]

Q2.

- (a) For a uniform of strength disc, that is,  $\sigma_1 = \sigma_2 = \sigma$ , rotating at an angular velocity of  $\omega$ , show that the thickness at any radius  $r$  is given by the expression

$$t = t_0 e^{-\frac{\rho r^2 \omega^2}{2\sigma}}$$

where  $t_0$  is the thickness at  $r = 0$ . The density of the disc may be taken as  $\rho$ . [10 marks]

- (b) A turbine rotor disc is 0.6 m diameter at the blade ring, and is keyed to a 50 mm diameter shaft. If the minimum thickness of the disc is 9.5 mm, what should be the thickness at the shaft for a uniform stress of 200 MPa at 10,000 rpm? Density = 7,700 kg/m<sup>3</sup>. [10 marks]

Q3.

A torque of 70 Nm is to be transmitted over a length of 1 metre in a piece of machinery. Two sections, both made of carbon steel, are being considered for the shaft design – a solid shaft of 25 mm × 25 mm square section and a hollow shaft of 25 mm × 25 mm square outside with a thickness of 1 mm.

- (a) Determine the maximum stress induced in each section. [10 marks]
- (b) Calculate the angle of twist for each section. [10 marks]
- (c) Calculate the torsional spring rate for each section. [Hint: The spring rate is defined as torque divided by the angle of twist.] [03 marks]
- (d) Which section would you recommend for use? Explain your choice. [02 marks]

Q4.

The solid circular shaft of diameter 100 mm is loaded as shown in Figure Q4 has a proportional limit of 450 MPa and a Poisson's ratio of 0.30.

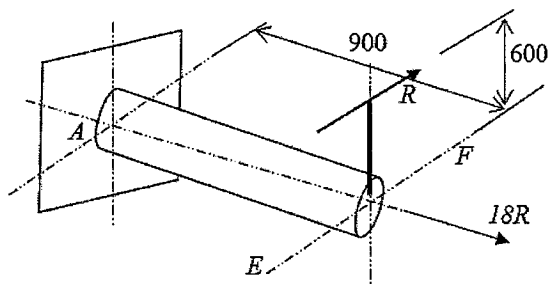

Figure Q4: Solid circular shaft (All dimensions are in mm)

Determine the value of the load  $R$  for failure as predicted by each of the given theories of failure. Assume that point  $A$  is the most severely stressed point.

- (a) Maximum principal stress theory [12 marks]
- (b) Maximum shear stress theory [03 marks]
- (c) Shear strain energy theory [05 marks]

Q5.

- (a) Lamé's equations are given below for radial and hoop stresses at any radius  $r$  for a thick cylinder of inner and outer radii  $r_i$  and  $r_o$  and under internal and external pressures  $p_i$  and  $p_o$ , respectively.

$$\sigma_r = \frac{p_i r_i^2 - p_o r_o^2}{(r_o^2 - r_i^2)} - \frac{(p_i - p_o) r_i^2 r_o^2}{(r_o^2 - r_i^2) r^2}$$

and

$$\sigma_\theta = \frac{p_i r_i^2 - p_o r_o^2}{(r_o^2 - r_i^2)} + \frac{(p_i - p_o) r_i^2 r_o^2}{(r_o^2 - r_i^2) r^2}$$

From these equations or otherwise, find the expressions for  $\sigma_r$  and  $\sigma_\theta$  for a thick cylinder under internal pressure only. [08 marks]

- (b) A thick cylinder of inner radius 10 cm and outer radius 15 cm is subjected to an internal pressure of 12 MPa. Determine the radial and hoop stresses in the cylinder at the inner and outer surfaces. [12 marks]

Q6.

- (a) The framework shown in Figure Q6 is pin-jointed to the ground at  $A$  and  $D$  and is loaded along  $AB$  with a distributed load  $w$ . If the flexural rigidity  $EI$  is constant throughout, obtain expressions for the reactions at  $A$  and  $D$  using the strain energy approach. [10 marks]

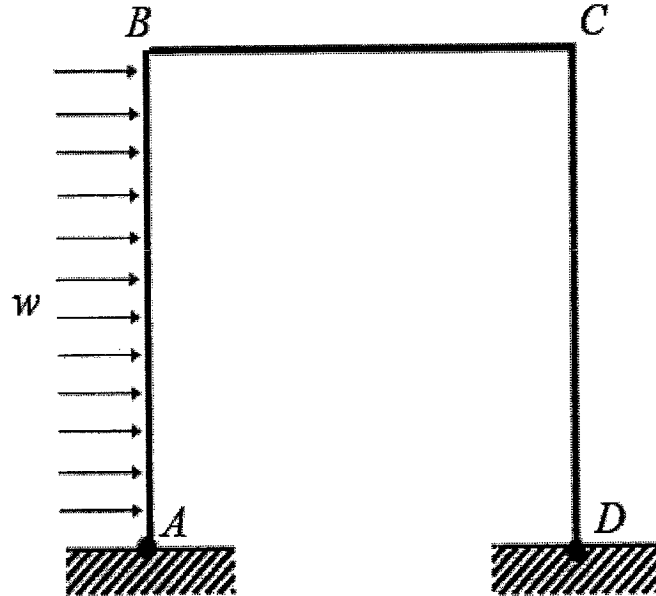

Figure Q6: Portal frame

- (b) If in Figure Q6  $EI$  is constant for the frame, and the dimensions of the frame are  $AB = CD = 4$  m and  $BC$  is  $\frac{1}{2}AB$ , calculate the horizontal and vertical reactions at  $A$  and  $D$  for  $w = 1,000$  kN/m. [10 marks]

Q7.

- (a) For an infinite beam on elastic foundations carrying a load  $W$  as shown in Figure Q7, the deflection solution is given by the expression

$$y = e^{\alpha x}(A \sin \alpha x + B \cos \alpha x) + e^{-\alpha x}(C \sin \alpha x + D \cos \alpha x)$$

where  $\alpha^4 = \frac{k}{4EI}$

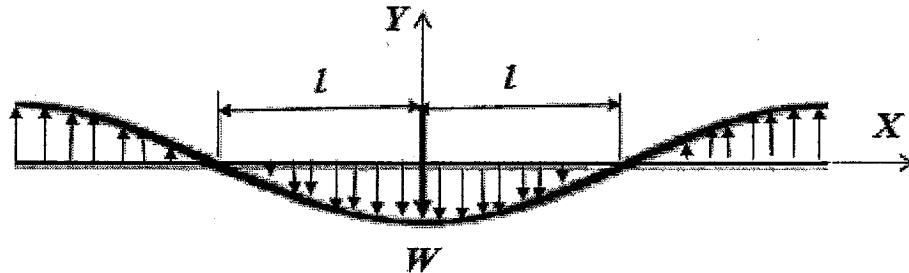

Figure Q7: Infinite beam on elastic foundation

Assuming that the support can exert pressure either upwards or downwards and taking the  $Y$  axis through the load  $W$  and the  $X$  axis at the un-deformed level, as shown, prove that the maximum deflection will be

$$\hat{y} = -\frac{W\alpha}{2k} \quad [10 \text{ marks}]$$

- (b) A steel railway track is supported on timber sleepers which exert an equivalent load of 2800 N/m length of rail per mm deflection from its unloaded position. For each rail  $I = 12 \times 10^6 \text{ mm}^4$ ,  $Z = 16 \times 10^4 \text{ mm}^3$  and  $E = 205,000 \text{ N/mm}^2$ . If a point load of 100 kN acts on each rail, find
- (i) the length of rail over which the sleepers are depressed [05 marks]
  - (ii) the maximum bending stress in the rail. [05 marks]

**END OF MEC 3352 EXAMINATION**  
**G M Munakaampe**

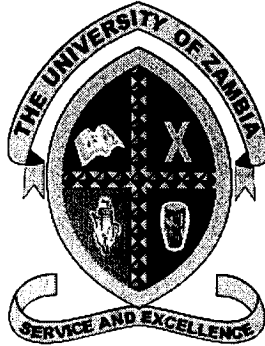

UNIVERSITY OF ZAMBIA  
SCHOOL OF ENGINEERING  
DEPARTMENT OF MECHANICAL ENGINEERING

## FINAL EXAMINATIONS FOR THE 2020 ACADEMIC YEAR

### MEC 3401: THERMODYNAMICS

TIME ALLOWED: THREE (3) HOURS

CLOSED BOOK

---

#### INSTRUCTIONS

1. Clearly indicate your **Computer Number** on the cover page of your answer booklet.
  2. Clearly indicate the **Name of the School, Department and Program** for which you are registered for on the cover page of your answer booklet.
  3. Answer a **TOTAL OF FIVE (5)** questions.
  4. Answer:  
  
**TWO (2) Questions from Section A.**  
  
**THREE (3) Questions from Section B.**
  5. If any of **Questions 3, and 7** is / are attempted, it / they should be tied together and submitted as a **separate booklet**.
  6. If any of **Questions 1, 2, 4, 5 and 6**, is / are attempted, it / they should be tied together and submitted as a **separate booklet**.
  7. ALL Questions carry **20 Marks**
  8. **THERMODYNAMIC STEAM TABLES ARE ALLOWED.**
  9. Draw neat sketches and graphs where necessary and clearly state any assumptions made.
-

## SECTION A: Answer Any Two Questions from this Section

---

### Question One

- (a) Derive the expression for *work done* for a *polytropic process*.
- (b) Describe the following with suitable examples:
- One-way* open system
  - Two Way* Open system
- (c) The inlet area of a gas turbine system is  $0.05\text{m}^2$ . Air enters the gas turbine system with a velocity of  $105\text{m/s}$  and has a specific volume of  $0.8\text{m}^3/\text{kg}$ . At exit, the air has a velocity of  $135\text{m/s}$  and has a specific volume of  $1.5\text{m}^3/\text{kg}$ . In its passage through the turbine system, the specific enthalpy of the air is reduced by  $145\text{kJ/kg}$  and the air also has a heat transfer loss of  $27\text{kJ/kg}$ . Determine:
- The mass flow rate of the air through the turbine system in  $\text{kg/s}$ .
  - The exit diameter of the turbine system in  $\text{m}^2$ .
  - The power developed by the turbine system in  $\text{kW}$ .

[6+4+10 = 20 Marks]

### Question Two

- (a) Due to energy shortage from Hydro power, the Government of Zambia is considering the use of power from nuclear power reactors. Describe in detail using a sketch how steam can be generated using *nuclear* reaction.
- (b) What is a *feed water heater*?
- (c) Describe the following with the help of neat labelled sketches:
- Closed* type feed water heater
  - Open* type feed water heater

[10+2+8 = 20Marks]

### Question Three

- (a) Define "*combustion*".
- (b) Describe with help of diagrams *design features* of Heat Engines.
- (c) Discuss classification of *fuels* suitable for use in Heat Engines.

[2+8+10 = 20 Marks]

**SECTION B: Answer Any Three Questions from this Section**

**Question Four**

- (a) Briefly explain giving reasons, which of the two engine types has a higher efficiency – *Petrol or Diesel?*
- (b) What do you mean by “*cut off ratio*” in a diesel engine?
- (d) A certain engine is based on the *diesel cycle*. At the beginning of compression, the pressure and temperature of gas is found to be  $100\text{kN/m}^2$  and  $45^\circ\text{C}$  and respectively. If the volume ratio of the compression is  $16:1$  and the materials used to build the engine can withstand a maximum temperature of  $1600^\circ\text{C}$ . Give a sketch of the cycle and determine the following:
- The pressure and temperature at each of the cycle process change points (*Tabulate your results*)
  - The work done / kg of gas
  - The thermal efficiency
  - The work ratio
  - The mean effective pressure
  - The Carnot efficiency within the temperature limits

Take  $\gamma = 1.4$ ;  $C_p = 1.004\text{kJ/kgK}$ ;  $C_v = 0.716\text{kJ/kgK}$ ;  $R = 0.287\text{kJ/kgK}$

[2+2+16 = 20 Marks]

**Question Five**

The following readings were recorded at 10 - minute intervals during a session to assess the efficiency of a *Fulton boiler*.

Interval (10mins)	1	2	3	4	5	6
Feed Water Flow Rate ( $\text{cm}^3/\text{s}$ )	31.37	31.38	31.38	31.38	31.38	31.37
Feed Water Temperature ( $^\circ\text{C}$ )	25.0	25.0	25.0	25.0	25.0	25.0
Steam Gauge Pressure (Bar)	0	1.38	7.24	6.62	6.90	6.90
Fuel flow by volume (cm)	7.5	7.0	6.5	6.2	6.0	6.0
Fuel Temperature ( $^\circ\text{C}$ )	24.0	25.0	25.0	25.0	25.0	24.0
Steam Temperature ( $^\circ\text{C}$ )	25	25	90	124	134	138
Exhaust Flue Gas Temperature ( $^\circ\text{C}$ )	25	288	245	185	194	215

- Room temperature and humidity before taking readings =  $26.5^\circ\text{C}$ ; 36%
- Room temperature and humidity after taking readings =  $27.0^\circ\text{C}$ ; 36%
- Atmospheric pressure =  $657.7\text{mmHg}$
- Density of mercury =  $13,600\text{kg/m}^3$
- Fuel gauge conversion (cm to  $\text{cm}^3$ ) =  $\text{cm} \times 5360 = \text{cm}^3$
- Density of the fuel used =  $810\text{kg/m}^3$
- Calorific Value of the fuel used =  $46\text{MJ/kg}$

- (a) Determine the efficiency of the boiler and comment on the value obtained.
- (b) Why was it necessary to take readings for the exhaust flue gas temperature?

[18+2 = 20 Marks]

### Question Six

- (a) Explain with the help of line diagrams, the difference between a “refrigerator” and “heat pump”.
- (b) Briefly explain why is it important for the refrigerant entering the compressor of a refrigeration plant to be “dry saturated”.
- (c) A simple heat pump is used to heat up a certain room. It consists of an evaporator, compressor, condenser, and a throttle regulator. The heat pump works between pressure limits of  $0.567 \text{ MN/m}^2$  and  $1.084 \text{ MN/m}^2$ . At the beginning of compression, the freon-12 is assumed dry saturated, and after compression, it has a temperature of  $60^\circ\text{C}$ . At the end of the condensation process, the refrigerant is liquid but not undercooled. If the heat transfer required from the condenser unit is  $90 \text{ MJ/h}$ , assuming the specific heat capacity of superheated vapour to be constant, determine:
- (i) Mass flow rate of the *Freon-12* in  $\text{kg/h}$  assuming no energy loss.
  - (ii) Dryness fraction of *Freon-12* at entry to the evaporator.
  - (iii) The power of the driving motor assuming that only 73% of the power of the driving motor is available in the *Freon-12*.
  - (iv) The ratio of the heat transferred from the condenser to the power required to drive the motor in the same time.

Take Specific Heat Capacity of water =  $4.187 \text{ kJ/kgK}$

[4+2+14 = 20 Marks]

### Question Seven

- (a) Derive the *stoichiometric equation* for estimating the amount of air required for complete combustion of gaseous fuels.
- (b) Determine *theoretical air* required for the purpose of stoichiometric combustion of the gaseous fuels “Methane and Propane” used to produce heat in a boiler.
- (c) Determine the amount of *actual air* required for combustion for the same methane and propane if the boiler is operated at an air coefficient of 0.8.

[6+7+7 = 20 Marks]

---

End of MEC 3401 – 2020 Academic Year Thermodynamics Final Examination,  
November 2021.

Prepared By:  
Prof. F.D. Yamba and Mr. S.S. Virdy

TABLE 7. SATURATED WATER AND STEAM  
TEMPERATURES FROM THE TRIPLE POINT TO 100 °C

[100 kN/m<sup>2</sup> = 1 bar ≈ 14.5 lbf/in<sup>2</sup>]

Celsius temp., °C	t	Pressure kN/m <sup>2</sup>	Specific volume m <sup>3</sup> /kg		Specific internal energy kJ/kg		Specific enthalpy kJ/kg			Specific entropy kJ/kg K		Celsius temp., °C	t												
			Water v <sub>f</sub>	Steam v <sub>g</sub>	Water u <sub>f</sub>	Steam u <sub>g</sub>	Water h <sub>f</sub>	Evaporation h <sub>fg</sub>	Steam h <sub>g</sub>	Water s <sub>f</sub>	Steam s <sub>g</sub>														
														0.01	2	4	6	8	10	12	14	16	18	20	22
0.01	0.01	0.611	0.001000	206.2	zero	2375.6	+0.0	2501.6	2501.6	9.157	9.157	0.01	0.01												
2	2	0.705	0.001000	179.9	8.4	2378.3	8.4	2496.8	2505.2	0.031	9.105	2	2												
4	4	0.813	0.001000	157.3	16.8	2381.1	16.8	2492.1	2508.9	0.061	9.053	4	4												
6	6	0.935	0.001000	137.8	25.2	2383.8	25.2	2487.4	2512.6	0.091	9.001	6	6												
8	8	1.072	0.001000	121.0	33.6	2386.6	33.6	2482.6	2516.2	0.121	8.951	8	8												
10	10	1.227	0.001000	106.4	42.0	2389.3	42.0	2477.9	2519.9	0.151	8.902	10	10												
12	12	1.401	0.001000	93.8	50.4	2392.1	50.4	2473.2	2523.6	0.180	8.854	12	12												
14	14	1.597	0.001001	82.9	58.8	2394.8	58.8	2468.5	2527.2	0.210	8.806	14	14												
16	16	1.817	0.001001	73.4	67.1	2397.6	67.1	2463.8	2530.9	0.239	8.759	16	16												
18	18	2.062	0.001001	65.1	75.5	2400.3	75.5	2459.0	2534.5	0.268	8.713	18	18												
20	20	2.34	0.001002	57.8	83.9	2403.0	83.9	2454.3	2538.2	0.296	8.668	20	20												
22	22	2.64	0.001002	51.5	92.2	2405.8	92.2	2449.6	2541.8	0.325	8.624	22	22												
24	24	2.98	0.001003	45.9	100.6	2408.5	100.6	2444.9	2545.5	0.353	8.581	24	24												
25	25	3.17	0.001003	43.4	104.8	2409.9	104.8	2442.5	2547.3	0.367	8.559	25	25												
26	26	3.36	0.001003	41.0	108.9	2411.2	108.9	2440.2	2549.1	0.381	8.538	26	26												
28	28	3.78	0.001004	36.7	117.3	2414.0	117.3	2435.4	2552.7	0.409	8.496	28	28												
30	30	4.24	0.001004	32.9	125.7	2416.7	125.7	2430.7	2556.4	0.437	8.455	30	30												
32	32	4.75	0.001005	29.6	134.0	2419.4	134.0	2425.9	2560.0	0.464	8.414	32	32												
34	34	5.32	0.001006	26.6	142.4	2422.1	142.4	2421.2	2563.6	0.491	8.374	34	34												
36	36	5.94	0.001006	24.0	150.7	2424.8	150.7	2416.4	2567.2	0.518	8.335	36	36												
38	38	6.62	0.001007	21.6	159.1	2427.5	159.1	2411.7	2570.8	0.545	8.296	38	38												
40	40	7.38	0.001008	19.55	167.4	2430.2	167.4	2406.9	2574.4	0.572	8.258	40	40												
42	42	8.20	0.001009	17.69	175.8	2432.9	175.8	2402.1	2577.9	0.599	8.221	42	42												
44	44	9.10	0.001009	16.04	184.2	2435.6	184.2	2397.3	2581.5	0.625	8.184	44	44												
46	46	10.09	0.001010	14.56	192.5	2438.3	192.5	2392.5	2585.1	0.651	8.148	46	46												
48	48	11.16	0.001011	13.23	200.9	2440.9	200.9	2387.7	2588.6	0.678	8.113	48	48												

TABLE 8. SATURATED WATER AND STEAM

PRESSURES FROM THE TRIPLE POINT UP TO 100 kN/m<sup>2</sup> (1 BAR)

[100 kN/m<sup>2</sup> = 1 bar ≈ 14.5 lbf/in<sup>2</sup>]

Pressure kN/m <sup>2</sup> <i>p</i>	Celsius temp., °C <i>t</i>	Specific volume m <sup>3</sup> /kg		Specific internal energy kJ/kg		Specific enthalpy kJ/kg			Specific entropy kJ/kg K		Pressure kN/m <sup>2</sup> <i>p</i>
		Water <i>v<sub>f</sub></i>	Steam <i>v<sub>g</sub></i>	Water <i>u<sub>f</sub></i>	Steam <i>u<sub>g</sub></i>	Water <i>h<sub>f</sub></i>	Evaporation <i>h<sub>fg</sub></i>	Steam <i>h<sub>g</sub></i>	Water <i>s<sub>f</sub></i>	Steam <i>s<sub>g</sub></i>	
0.611	0.01	0.001000	206.2	zero	2375.6	+0.0	2501.6	2501.6	zero	9.157	0.611
0.8	3.8	0.001000	159.7	15.8	2380.7	15.8	2492.6	2508.5	0.058	9.058	0.8
1.0	7.0	0.001000	129.2	29.3	2385.2	29.3	2485.0	2514.4	0.106	8.977	1.0
1.2	9.7	0.001000	108.7	40.6	2388.9	40.6	2478.7	2519.3	0.146	8.910	1.2
1.4	12.0	0.001000	93.9	50.3	2392.0	50.3	2473.2	2523.5	0.180	8.854	1.4
1.6	14.0	0.001001	82.8	58.9	2394.8	58.9	2468.4	2527.3	0.210	8.805	1.6
1.8	15.9	0.001001	74.0	66.5	2397.4	66.5	2464.1	2530.6	0.237	8.763	1.8
2.0	17.5	0.001001	67.0	73.5	2399.6	73.5	2460.2	2533.6	0.261	8.725	2.0
2.2	19.0	0.001002	61.2	79.8	2401.7	79.8	2456.6	2536.4	0.282	8.690	2.2
2.4	20.4	0.001002	56.4	85.7	2403.6	85.7	2453.3	2539.0	0.302	8.659	2.4
2.6	21.7	0.001002	52.3	91.1	2405.4	91.1	2450.2	2541.3	0.321	8.630	2.6
2.8	23.0	0.001002	48.7	96.2	2407.1	96.2	2447.3	2543.6	0.338	8.603	2.8
3.0	24.1	0.001003	45.7	101.0	2408.6	101.0	2444.6	2545.6	0.354	8.578	3.0
3.5	26.7	0.001003	39.5	111.8	2412.2	111.8	2438.5	2550.4	0.391	8.523	3.5
4.0	29.0	0.001004	34.8	121.4	2415.3	121.4	2433.1	2554.5	0.422	8.475	4.0
4.5	31.0	0.001005	31.1	130.0	2418.1	130.0	2428.2	2558.2	0.451	8.433	4.5
5.0	32.9	0.001005	28.2	137.8	2420.6	137.8	2423.8	2561.6	0.476	8.396	5.0
6	36.2	0.001006	23.74	151.5	2425.1	151.5	2416.0	2567.5	0.521	8.331	6
7	39.0	0.001007	20.53	163.4	2428.9	163.4	2409.2	2572.6	0.559	8.277	7
8	41.5	0.001008	18.10	173.9	2432.3	173.9	2403.2	2577.1	0.593	8.230	8
9	43.8	0.001009	16.20	183.3	2435.3	183.3	2397.9	2581.1	0.622	8.188	9
10	45.8	0.001010	14.67	191.8	2438.0	191.8	2392.9	2584.8	0.649	8.151	10
11	47.7	0.001011	13.42	199.7	2440.5	199.7	2388.4	2588.1	0.674	8.118	11
12	49.4	0.001012	12.36	206.9	2442.8	206.9	2384.3	2591.2	0.696	8.087	12
13	51.1	0.001013	11.47	213.7	2445.0	213.7	2380.4	2594.0	0.717	8.059	13
14	52.6	0.001013	10.69	220.0	2447.0	220.0	2376.7	2596.7	0.737	8.033	14
15	54.0	0.001014	10.02	226.0	2448.0	226.0	2373.2	2599.2	0.755	8.009	15

Pressure in kN/B<sup>2</sup>

TABLE 8 (cont.). SATURATED WATER AND STEAM  
 PRESSURES FROM 0.1 TO 3.0 MN/m<sup>2</sup> (1 TO 30 BAR)

[0.1 MN/m<sup>2</sup> = 1 bar ≈ 14.5 lbf/in<sup>2</sup>]

Pressure MN/m <sup>2</sup> <i>p</i>	Celsius temp., °C <i>t</i>	Specific volume m <sup>3</sup> /kg		Specific internal energy kJ/kg		Specific enthalpy kJ/kg			Specific entropy kJ/kg K		Pressure MN/m <sup>2</sup> <i>p</i>
		m <sup>3</sup> /kg		kJ/kg		kJ/kg			kJ/kg K		
		Water <i>v<sub>f</sub></i>	Steam <i>v<sub>g</sub></i>	Water <i>u<sub>f</sub></i>	Steam <i>u<sub>g</sub></i>	Water <i>h<sub>f</sub></i>	Evaporation <i>h<sub>fg</sub></i>	Steam <i>h<sub>g</sub></i>	Water <i>s<sub>f</sub></i>	Steam <i>s<sub>g</sub></i>	
0.10	99.6	0.001043	1.694	417.4	2506.1	417.5	2257.9	2675.4	1.303	7.360	0.10
0.11	102.3	0.001046	1.549	428.7	2509.2	428.8	2250.8	2679.6	1.333	7.328	0.11
0.12	104.8	0.001048	1.428	439.2	2512.1	439.4	2244.1	2683.4	1.361	7.298	0.12
0.13	107.1	0.001049	1.325	449.1	2514.7	449.2	2237.8	2687.0	1.387	7.271	0.13
0.14	109.3	0.001051	1.236	458.3	2517.2	458.4	2231.9	2690.3	1.411	7.247	0.14
0.15	111.4	0.001053	1.159	467.0	2519.5	467.1	2226.2	2693.4	1.434	7.223	0.15
0.16	113.3	0.001055	1.091	475.2	2521.7	475.4	2220.9	2696.2	1.455	7.202	0.16
0.17	115.2	0.001056	1.031	483.0	2523.7	483.2	2215.7	2699.0	1.475	7.181	0.17
0.18	116.9	0.001058	0.977	490.5	2525.6	490.7	2210.8	2701.5	1.494	7.162	0.18
0.19	118.6	0.001059	0.929	497.6	2527.5	497.8	2206.1	2704.0	1.513	7.144	0.19
0.20	120.2	0.001061	0.885	504.5	2529.2	504.7	2201.6	2706.3	1.530	7.127	0.20
0.22	123.3	0.001064	0.810	517.4	2532.4	517.6	2193.0	2710.6	1.563	7.095	0.22
0.24	126.1	0.001066	0.746	529.4	2535.4	529.6	2184.9	2714.5	1.593	7.066	0.24
0.26	128.7	0.001069	0.693	540.6	2538.1	540.9	2177.3	2718.2	1.621	7.039	0.26
0.28	131.2	0.001071	0.646	551.1	2540.6	551.4	2170.1	2721.5	1.647	7.014	0.28
0.30	133.5	0.001074	0.606	561.1	2543.0	561.4	2163.2	2724.7	1.672	6.991	0.30
0.32	135.8	0.001076	0.570	570.6	2545.2	570.9	2156.7	2727.6	1.695	6.969	0.32
0.34	137.9	0.001078	0.538	579.6	2547.2	579.9	2150.4	2730.3	1.717	6.949	0.34
0.36	139.9	0.001080	0.510	588.1	2549.2	588.5	2144.4	2732.9	1.738	6.930	0.36
0.38	141.8	0.001082	0.485	596.4	2551.0	596.8	2138.6	2735.3	1.757	6.912	0.38
0.40	143.6	0.001084	0.462	604.2	2552.7	604.7	2133.0	2737.6	1.776	6.894	0.40
0.42	145.4	0.001086	0.442	611.8	2554.4	612.3	2127.5	2739.8	1.795	6.878	0.42
0.44	147.1	0.001088	0.423	619.1	2555.9	619.6	2122.3	2741.9	1.812	6.862	0.44
0.46	148.7	0.001089	0.405	626.2	2557.4	626.7	2117.2	2743.9	1.829	6.847	0.46
0.48	150.3	0.001091	0.389	633.0	2558.8	633.5	2112.2	2745.7	1.845	6.833	0.48
0.50	151.8	0.001093	0.375	639.6	2560.2	640.1	2107.4	2747.5	1.860	6.819	0.50
0.55	155.5	0.001097	0.342	655.2	2563.3	655.8	2095.9	2751.7	1.897	6.787	0.55
0.60	158.8	0.001101	0.315	669.8	2566.2	670.4	2085.0	2755.5	1.931	6.758	0.60
0.65	162.0	0.001105	0.292	683.4	2568.7	684.1	2074.7	2758.9	1.962	6.730	0.65
0.70	165.0	0.001108	0.273	696.3	2571.1	697.1	2064.9	2762.0	1.992	6.705	0.70

Pressure in MN/m<sup>2</sup>

$p$	$t$	$v_f$	$v_g$	$u_f$	$u_g$	$h_f$	$h_{fg}$	$h_g$	$s_f$	$s_g$	$p$
0.75	167.8	0.001112	0.2554	708.5	2573.3	709.3	2055.5	2764.8	2.020	6.682	0.75
0.80	170.4	0.001115	0.2403	720.0	2575.3	720.9	2046.5	2767.5	2.046	6.660	0.80
0.85	172.9	0.001118	0.2268	731.1	2577.1	732.0	2037.9	2769.9	2.071	6.639	0.85
0.90	175.4	0.001121	0.2148	741.6	2578.8	742.6	2029.5	2772.1	2.094	6.619	0.90
0.95	177.7	0.001124	0.2040	751.8	2580.4	752.8	2021.4	2774.2	2.117	6.601	0.95
1.00	179.9	0.001127	0.1943	761.5	2581.9	762.6	2013.6	2776.2	2.138	6.583	1.00
1.05	182.0	0.001130	0.1855	770.8	2583.3	772.0	2005.9	2778.0	2.159	6.566	1.05
1.10	184.1	0.001133	0.1774	779.9	2584.5	781.1	1998.5	2779.7	2.179	6.550	1.10
1.15	186.0	0.001136	0.1700	788.6	2585.8	789.9	1991.3	2781.3	2.198	6.534	1.15
1.20	188.0	0.001139	0.1632	797.1	2586.9	798.4	1984.3	2782.7	2.216	6.519	1.20
1.25	189.8	0.001141	0.1569	805.3	2588.0	806.7	1977.4	2784.1	2.234	6.505	1.25
1.30	191.6	0.001144	0.1511	813.2	2589.0	814.7	1970.7	2785.4	2.251	6.491	1.30
1.4	195.0	0.001149	0.1407	828.5	2590.8	830.1	1957.7	2787.8	2.284	6.465	1.4
1.5	198.3	0.001154	0.1317	842.9	2592.4	844.7	1945.2	2789.9	2.314	6.441	1.5
1.6	201.4	0.001159	0.1237	856.7	2593.8	858.6	1933.2	2791.7	2.344	6.418	1.6
1.7	204.3	0.001163	0.1166	869.9	2595.1	871.8	1921.5	2793.4	2.371	6.396	1.7
1.8	207.1	0.001168	0.1103	882.5	2596.3	884.6	1910.3	2794.8	2.398	6.375	1.8
1.9	209.8	0.001172	0.1047	894.6	2597.3	896.8	1899.3	2796.1	2.423	6.355	1.9
2.0	212.4	0.001177	0.0995	906.2	2598.2	908.6	1888.6	2797.2	2.447	6.337	2.0
2.1	214.9	0.001181	0.0949	917.5	2598.9	920.0	1878.2	2798.2	2.470	6.319	2.1
2.2	217.2	0.001185	0.0907	928.3	2599.6	931.0	1868.1	2799.1	2.492	6.301	2.2
2.3	219.6	0.001189	0.0868	938.9	2600.2	941.6	1858.2	2799.8	2.514	6.285	2.3
2.4	221.8	0.001193	0.0832	949.1	2600.7	951.9	1848.5	2800.4	2.534	6.269	2.4
2.5	223.9	0.001197	0.0799	959.0	2601.2	962.0	1839.0	2800.9	2.554	6.254	2.5
2.6	226.0	0.001201	0.0769	968.6	2601.5	971.7	1829.6	2801.4	2.574	6.239	2.6
2.7	228.1	0.001205	0.0740	978.0	2601.8	981.2	1820.5	2801.7	2.592	6.224	2.7
2.8	230.0	0.001209	0.0714	987.1	2602.1	990.5	1811.5	2802.0	2.611	6.210	2.8
2.9	232.0	0.001213	0.0689	996.0	2602.3	999.5	1802.6	2802.2	2.628	6.197	2.9
3.0	233.8	0.001216	0.0666	1004.7	2602.4	1008.4	1793.9	2802.3	2.646	6.184	3.0

Pressure in MN/m<sup>2</sup>

TABLE 9. SPECIFIC ENTHALPY OF WATER AND STEAM

[0.1 MN/m<sup>2</sup> = 1 bar ≈ 14.5 lbf/in<sup>2</sup>]

Pressure/(MN/m <sup>2</sup> ) Pressure/bar	Sat. Celsius temp., °C	Specific enthalpy/(kJ/kg)																Celsius temp., °C			
		0	0.1	1	10	2	4	6	8	10	15	20	22.12	25	30	40	50		1000		
0	0.01	0.0	0.0	0.1	0.5	1.0	2.0	4.0	6.1	8.1	10.1	15.1	20.1	22.2	25.1	30.0	39.7	49.3	95.9		
25	0.1	104.8	104.8	104.9	105.2	105.7	106.6	108.5	110.3	112.1	114.0	118.6	123.1	125.1	127.7	132.2	141.2	150.2	193.9		
50	1.0	2595	2593	209.3	209.7	210.1	211.0	212.7	214.4	216.1	217.8	222.1	226.4	228.2	230.7	235.0	243.5	251.9	293.9		
75	10	2642	2640	313.9	314.0	314.3	314.7	315.5	317.1	318.7	320.3	322.0	326.0	330.0	331.7	334.0	338.1	346.1	354.2	394.3	
100	100	2689	2688	2683	2676	419.4	419.7	420.5	422.0	423.5	425.0	426.5	430.3	434.0	435.7	437.8	441.6	449.2	456.8	495.1	
125	1000	2736	2735	2731	2726	525.2	525.5	526.2	527.6	529.0	530.4	531.8	535.3	538.8	540.2	542.3	545.8	552.9	560.1	596.3	
150	10000	2784	2783	2780	2776	632.2	632.5	633.1	634.3	635.6	636.8	638.1	641.3	644.5	645.8	647.7	650.9	657.4	664.1	698.0	
175	100000	2832	2831	2829	2826	741.1	741.1	741.7	742.7	743.8	744.9	746.0	748.7	751.5	752.7	754.4	757.2	763.1	769.1	800.4	
200	1000000	2880	2880	2878	2875	852.6	852.6	853.4	854.2	855.1	855.9	858.1	860.4	861.4	862.8	865.2	870.2	875.4	901.5	200	
225	10000000	2929	2928	2927	2925	967.2	967.2	967.7	968.2	968.8	970.3	971.8	972.5	973.5	975.3	979.2	983.4	1007.7	225		
250	100000000	2978	2977	2976	2975	1085.8	1085.8	1085.8	1085.8	1085.8	1086.2	1086.7	1087.0	1087.5	1088.4	1090.8	1093.6	1113.0	250		
275	1000000000	3027	3027	3026	3024	1210.8	1210.8	1210.8	1209.2	1207.7	1206.6	1206.3	1205.9	1205.9	1205.7	1206.7	1219.9	275			
300	10000000000	3077	3077	3076	3074	1343.4	1343.4	1338.3	1334.3	1332.8	1331.1	1328.7	1325.4	1323.7	1323.7	1328.7	300				
325	100000000000	3127	3127	3126	3125	1486.0	1486.0	1475.5	1471.8	1467.4	1461.1	1452.0	1446.0	1439.1	1439.1	325					
350	1000000000000	3177	3177	3177	3176	1647.1	1647.1	1636.5	1625.0	1609.9	1589.6	1576.3	1550.5	1550.5	350						
375	10000000000000	3228	3228	3228	3227	2604	2604	2319	1849	1791	1742	1716	1671	1671	375						
400	100000000000000	3280	3280	3279	3278	3264	3249	3216	3180	3142	3100	2979	2820	2733	2582	2162	1934	1878	1798	400	
425	1000000000000000	3331	3331	3331	3330	3325	3317	3303	3274	3243	3209	3174	3075	2957	2899	2810	2619	2208	2068	1924	425
450	10000000000000000	3384	3384	3383	3382	3377	3371	3358	3331	3303	3274	3244	3160	3064	3020	2954	2826	2516	2293	2051	450
475	100000000000000000	3436	3436	3436	3435	3430	3424	3412	3388	3363	3337	3310	3237	3157	3120	3068	2969	2743	2522	2181	475
500	1000000000000000000	3489	3489	3489	3488	3484	3478	3457	3445	3422	3399	3375	3311	3241	3210	3166	3085	2907	2723	2316	500
550	10000000000000000000	3597	3596	3596	3596	3592	3587	3578	3559	3539	3520	3500	3448	3394	3370	3337	3277	3152	3021	2594	550
600	100000000000000000000	3706	3706	3705	3705	3702	3697	3689	3673	3656	3640	3623	3580	3536	3516	3490	3443	3346	3248	2857	600
650	1000000000000000000000	3816	3816	3816	3816	3813	3809	3802	3788	3774	3759	3745	3708	3671	3655	3633	3595	3517	3439	3105	650
700	10000000000000000000000	3929	3929	3929	3928	3926	3923	3916	3904	3892	3879	3867	3835	3804	3790	3772	3740	3675	3610	3324	700
750	100000000000000000000000	4043	4043	4043	4042	4040	4038	4032	4021	4011	4000	3989	3962	3935	3923	3908	3880	3825	3771	3526	750
800	1000000000000000000000000	4159	4159	4159	4158	4156	4154	4149	4140	4131	4121	4112	4089	4065	4055	4042	4018	3972	3925	3714	800

TABLE 13. PROPERTIES OF REFRIGERANT-12, CCl<sub>2</sub>F<sub>2</sub>

[0.1 MN/m<sup>2</sup> = 1 bar ≈ 14.5 lbf/in<sup>2</sup>]

Saturation Celsius temp., °C <i>t</i>	Pressure MN/m <sup>2</sup> <i>p</i>	Saturated										Superheated					
		Specific volume m <sup>3</sup> /kg		Specific enthalpy kJ/kg				Specific entropy kJ/kg K				By 20 K		By 40 K			
		Liquid <i>v<sub>l</sub></i>	Vapour <i>v<sub>g</sub></i>	Liquid <i>h<sub>l</sub></i>	Vapour <i>h<sub>g</sub></i>	Liquid <i>s<sub>l</sub></i>	Vapour <i>s<sub>g</sub></i>	Liquid <i>s<sub>l</sub></i>	Vapour <i>s<sub>g</sub></i>	<i>h</i>	<i>s</i>	<i>h</i>	<i>s</i>	<i>h</i>	<i>s</i>		
-40	0.0641	0.00066	0.2421	zero	169.6	zero	0.7274	zero	0.7274	180.8	0.7737	192.4	0.8178				
-35	0.0806	0.00067	0.1955	4.4	171.9	0.0187	0.7220	0.0187	0.7220	183.3	0.7681	195.1	0.8120				
-30	0.1003	0.00067	0.1595	8.9	174.2	0.0371	0.7171	0.0371	0.7171	185.8	0.7631	197.8	0.8068				
-25	0.1236	0.00068	0.1313	13.3	176.5	0.0552	0.7127	0.0552	0.7127	188.3	0.7586	200.4	0.8021				
-20	0.1508	0.00069	0.1089	17.8	178.7	0.0731	0.7088	0.0731	0.7088	190.8	0.7546	203.1	0.7979				
-15	0.1825	0.00069	0.0911	22.3	181.0	0.0906	0.7052	0.0906	0.7052	193.2	0.7510	205.7	0.7942				
-10	0.219	0.00070	0.0767	26.9	183.2	0.1080	0.7020	0.1080	0.7020	195.7	0.7477	208.3	0.7909				
-5	0.261	0.00071	0.0650	31.4	185.4	0.1251	0.6991	0.1251	0.6991	198.1	0.7449	210.9	0.7879				
0	0.308	0.00072	0.0554	36.1	187.5	0.1420	0.6966	0.1420	0.6966	200.5	0.7423	213.5	0.7853				
5	0.362	0.00072	0.0475	40.7	189.7	0.1587	0.6942	0.1587	0.6942	202.9	0.7401	216.1	0.7830				
10	0.423	0.00073	0.0409	45.4	191.7	0.1752	0.6921	0.1752	0.6921	205.2	0.7381	218.6	0.7810				
15	0.491	0.00074	0.0354	50.1	193.8	0.1915	0.6902	0.1915	0.6902	207.5	0.7363	221.2	0.7792				
20	0.567	0.00075	0.0308	54.9	195.8	0.2078	0.6885	0.2078	0.6885	209.8	0.7348	223.7	0.7777				
25	0.651	0.00076	0.0269	59.7	197.7	0.2239	0.6869	0.2239	0.6869	212.1	0.7334	226.1	0.7763				
30	0.745	0.00077	0.0235	64.6	199.6	0.2399	0.6854	0.2399	0.6854	214.3	0.7321	228.6	0.7751				
35	0.847	0.00079	0.0206	69.5	201.5	0.2559	0.6839	0.2559	0.6839	216.4	0.7310	231.0	0.7741				
40	0.960	0.00080	0.0182	74.6	203.2	0.2718	0.6825	0.2718	0.6825	218.5	0.7300	233.4	0.7732				
45	1.084	0.00081	0.0160	79.7	204.9	0.2877	0.6812	0.2877	0.6812	220.6	0.7291	235.7	0.7724				
50	1.219	0.00083	0.0142	84.9	206.5	0.3037	0.6797	0.3037	0.6797	222.6	0.7282	238.0	0.7718				

Freezing point at 1 atm = -155.0 °C

Critical point: Celsius temp. = 112.0 °C

pressure = 4.115 MN/m<sup>2</sup> (41.15 bar)

**THE UNIVERSITY OF ZAMBIA  
SCHOOL OF ENGINEERING  
DEPARTMENT OF MECHANICAL ENGINEERING  
UNIVERSITY EXAMINATIONS FOR 2021 ACADEMIC YEAR  
MEC 4055 – MACHINE DESIGN I  
DEFERRED EXAMINATION  
PAPER I**

---

---

**INSTRUCTIONS TO CANDIDATES:**

1. Candidates are allowed to use books, and notes (**Open Book Examination**).
2. Time: **Three (3) hours**
3. Answer FIVE (5) questions.
4. Calculators and drawing instruments are permitted.

---

---

**DO NOT TURN THIS PAGE UNTIL YOU ARE TOLD TO DO SO**

**Q1.**

The C-clamp shown in Figure Q1 uses a 10 mm screw (assumed square) with a pitch of 2 mm. The frictional coefficient is 0.15 for both the threads and the collar. The collar has a frictional diameter of 16 mm. The handle is made of steel with allowable bending stress of 165 MPa. The capacity of the clamp is 700 N.

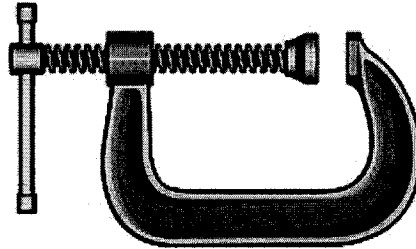
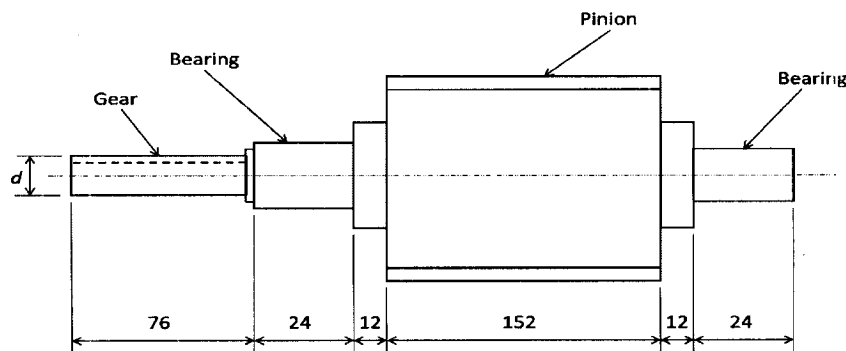

**Figure Q1: C-clamp**

- (a) Find the torque required to tighten the clamp to full capacity. [05 marks]
- (b) Specify the length and diameter of the handle (both to the nearest 10 mm) such that it will not bend unless the rated capacity of the clamp is exceeded. Use 15 N as the handle force. [08 marks]
- (c) Find the combined efficiency of the screw and the collar. [04 marks]
- (d) Check whether or not the screw without the collar is self-locking. [03 marks]

**Q2.**

A 6.67 kN gear is to be mounted on the overhang of a 13.34 kN integral pinion shaft as shown in Figure Q2. The weights of the gear and the pinion are assumed to act as concentrated loads with equal and opposite torques, of magnitude 452 Nm, acting at the centre of the shaft overhang and centre of the pinion, respectively.



**Figure Q2: Integral pinion shaft**

- (a) Draw the bending moment diagram along with the torques and forces acting on the shaft. [10 marks]
- (b) Taking the factor of safety as 2, calculate the safe diameter,  $d$ , of the overhang shaft if the yield strength and endurance limit of the material selected are 483 MPa and 172 MPa, respectively. Use the Maximum shear Stress theory and the Solderberg approach. [10 marks]

### Q3.

Your Company is concerned about the excessive wear and tear that is induced between the roller grooves and chain belts due to sudden change in rotational direction at high speed. As a graduate engineer, you figure out that the remedy to this concern is to design, for the conveyor's roller system, the simple band brakes to be able to stop the rollers temporarily before they change their rotational direction. The band brake drum (dia = 0.3 m) is to be fixed to the roller (dia = 0.18 m) and the roller runs at 400 rpm, maximum speed, as it transmits power of up to 3 kW to the drum. The coefficient of friction is 0.29. Given that the design parameters under your consideration are as in the figure below;

Determine:

- The operating force,  $P$ . Considering that you are designing hand brakes, what measures would you consider to ensure that the operating force stays within operational limit? [13 marks]
- Specify the allowable extension per unit length of the cord. Consider a circular cord cross section (dia = 0.07 m). [07 marks]

NOTE: All linear dimensions in the figure are in mm, and  $E = 30$  GPa for the cord material.

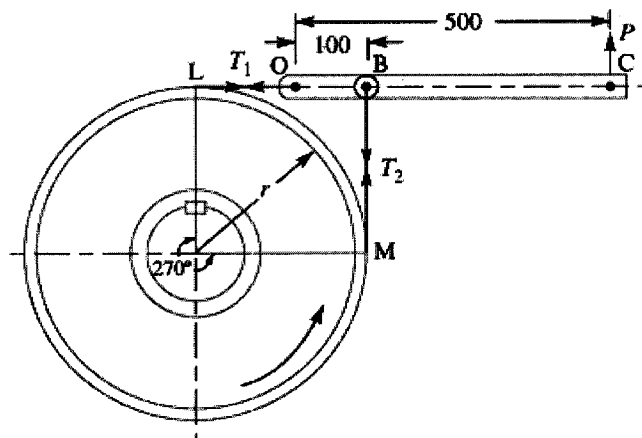

Figure Q3: Simple Band Brake

### Q4.

The engine of a car transmits power to the driven shaft a rate 30 kJ/s when running at 2,400 rpm. The torque is to be smoothly transmitted from the driving to driven-shaft with an axial force of 3 kN. Take the clutch friction material coefficient,  $\mu = 0.1$ :

- Determine the inner and outer radii for the clutch plate such that the ratio of the inner radius to outer is  $2/3$  for uniform pressure design. [08 marks]
- Using the radii determined in (a), estimate the friction torque by the uniform wear model. [06 marks]
- Estimate the amount of heat generated in a 4 kg clutch material if the temperature rise recorded on clutch engagement is  $5^\circ\text{C}$ . Take  $c_p = 0.49$  kJ/kg. $^\circ\text{C}$  [06 marks]

**Q5.**

A tram attains engine power 60 kW at 1,200 rpm crankshaft rotational speed. If the gear train delivers torque to the rear wheels at 90% efficiency and the car rim diameter is 0.6m. Design for this car a single block (shoe) brakes to be fitted on the rear wheels and neglecting the braking requirements on the front wheels. In your design, consider a scenario where the line of action of the tangential braking force passes through a distance, say “a” below the pivot and the rotation is clockwise. Given that the distance from the point where the actuating force acts to the fulcrum,  $l = 0.45$  m; the distance from the point of normal force to the fulcrum,  $x = 0.2$  m;  $a = 0.06$  m and the angle of contact surface of the block,  $\theta = 30^\circ$ .

- (a) The friction material to be used. [02 marks]
- (b) Determine the actuating force necessary to stop the car [12 marks]
- (c) If the car speed reduces to one-third  $2/5$  of the initial speed, determine the distance it can covered in 3 s of braking. [06 marks]

**Q6.**

A structure contains a critical component made from A514 steel. After fabrication of the structure, a welding defect 7.6 mm deep is discovered in this steel plate. The flaw is essentially an edge crack under tension loading, and the required cyclic life of the structure is 100,000 cycles. The component is subject to a fluctuating load which causes a stress variation from 172 MPa to 310 MPa.

Material properties for the A514 steel are: yield stress = 689 MPa,  $K_{IC} = 165$  MPa  $m^{1/2}$  geometry correction factor  $Y = 1.12$ , and  $C = 1.36 \times 10^{-10}$  and  $m = 2.25$  in the Paris Law equation; where  $da/dN$  is in m/cycle.

Calculate the fatigue life of this component based on attaining a critical defect size for fast fracture. [20 marks]

**Q7.**

A 02-series ball bearing is to be selected to carry a radial load of 10 kN and a thrust of 3 kN. The desired life  $L_D$  is to be 3,500 h with the outer racer rotation rate of 1,000 r/min.

- (a) What is the basic load rating that should be used in selecting a bearing for a reliability goal of 0.87? Specify the selected bearing for this purpose. [10 marks]
- (b) Supposed the bearing selected in (a) is to be sized to have a reliability of 0.96. What basic rating should be used in selecting the bearing? Specify the selected bearing for this purpose. [10 marks]

Additional information can be sourced from Tables 1 and 2 provided overleaf.

**Table 1: Equivalent radial load factors for ball bearings.**

$F_o/C_o$	$e$	$F_o/(VF_r) < e$		$F_o/(VF_r) > e$	
		$X_1$	$Y_1$	$X_2$	$Y_2$
0.014*	0.19	1.00	0	0.56	2.30
0.021	0.21	1.00	0	0.56	2.15
0.028	0.22	1.00	0	0.56	1.99
0.042	0.24	1.00	0	0.56	1.85
0.056	0.26	1.00	0	0.56	1.71
0.070	0.27	1.00	0	0.56	1.63
0.084	0.28	1.00	0	0.56	1.55
0.110	0.30	1.00	0	0.56	1.45
0.17	0.34	1.00	0	0.56	1.31
0.28	0.38	1.00	0	0.56	1.15
0.42	0.42	1.00	0	0.56	1.04
0.56	0.44	1.00	0	0.56	1.00

**Table 2: Dimensions and load ratings for single-row 02-series deep groove and angular-contact bearings**

Bore, mm	OD, mm	Width, mm	Fillet Radius, mm	Shoulder		Load Ratings, kN			
				Diameter, mm $d_s$	$d_r$	Deep Groove		Angular Contact	
						C	$C_o$	C	$C_o$
10	30	9	0.6	12.5	27	5.07	2.24	4.94	2.12
12	32	10	0.6	14.5	28	6.89	3.10	7.02	3.05
15	35	11	0.6	17.5	31	7.80	3.55	8.06	3.65
17	40	12	0.6	19.5	34	9.56	4.50	9.95	4.75
20	47	14	1.0	25	41	12.7	6.20	13.3	6.55
25	52	15	1.0	30	47	14.0	6.95	14.8	7.65
30	62	16	1.0	35	55	19.5	10.0	20.3	11.0
35	72	17	1.0	41	65	25.5	13.7	27.0	15.0
40	80	18	1.0	46	72	30.7	16.6	31.9	18.6
45	85	19	1.0	52	77	33.2	18.6	35.8	21.2
50	90	20	1.0	56	82	35.1	19.6	37.7	22.8
55	100	21	1.5	63	90	43.6	25.0	46.2	28.5
60	110	22	1.5	70	99	47.5	28.0	55.9	35.5
65	120	23	1.5	74	109	55.9	34.0	63.7	41.5
70	125	24	1.5	79	114	61.8	37.5	68.9	45.5
75	130	25	1.5	86	119	66.3	40.5	71.5	49.0
80	140	26	2.0	93	127	70.2	45.0	80.6	55.0
85	150	28	2.0	99	136	83.2	53.0	90.4	63.0
90	160	30	2.0	104	146	95.6	62.0	106	73.5
95	170	32	2.0	110	156	108	69.5	121	85.0

**END OF MEC4055 EXAMINATION PAPER I**

**Prof. S. B. Kanyanga, Dr. C. G. Chizyuka & G. M. Munakaampe**

THE UNIVERSITY OF ZAMBIA  
SCHOOL OF ENGINEERING  
DEPARTMENT OF MECHANICAL ENGINEERING

UNIVERSITY EXAMINATIONS

2020/2021 ACADEMIC YEAR

MEC 4055 – MACHINE DESIGN I  
PAPER II

---

**INSTRUCTIONS TO CANDIDATES:**

1. Candidates are allowed to use books, and notes (**Open Book Examination**).
  2. This paper has **two (2)** printed pages including this cover page.
  3. Time: **Three (3)** hours.
  4. Answer **ALL** questions.
  5. Calculators and drawing instruments are permitted.
- 

**DO NOT TURN THIS PAGE UNTIL YOU ARE TOLD TO DO SO**

You have been approached to design a machine for cutting potatoes into chips as shown in Figure 1. The machine should be able to cut potatoes into chips of a cross section size of about  $8 \times 8$  mm and lengths varying from 40 to 80 mm. It should be electrically powered and able to produce 200 kg of chips per hour. The potatoes are of various sizes and peeled by hand.

- Q1. Write a detailed product design specification (PDS) for the machine. [20 marks]
- Q2. Produce TWO (2) different functional designs for the above machine and explain how they will be operated. [60 marks]
- Q3. Select the better of the two designs using four (5) relevant design factors. [20 marks]



*(a) Potatoes*

*(b) Chips*

*Figure 1: Potatoes and chips*

---

**END OF MEC4055 PAPER II EXAMINATION**  
**Prof. S. B. Kanyanga, Dr. C. G. Chizyuka & G. M. Munakaampe**

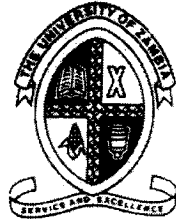

**THE UNIVERSITY OF ZAMBIA**

**SCHOOL OF ENGINEERING**

**DEPARTMENT OF MECHANICAL ENGINEERING**

**FINAL EXAMINATIONS – NOVEMBER /DECEMBER 2021**

**MEC 4105 - PRODUCTION TECHNOLOGY I**

Time allowed: 3 HOURS plus 5 minutes reading time

Instructions to Candidates:

1. Check that you have the correct examination paper in front of you. There is one page excluding this cover page.
2. This is a **Closed Book** examination.
3. There are **FIVE (5)** Questions in this paper.
4. Attempt any **FOUR (4)** Questions only.
5. All questions must be answered in the answer booklet provided only.
6. Write down the question number of each question that you have answered in the provided boxes on the cover of the examination answer booklet.
7. Begin each new solution on a new page.
8. Non-programmable calculators and drawing instruments are allowed.
9. There shall be no form of communication between students during the examination. Any students caught doing this will be disqualified.

**DO NOT TURN THIS PAGE UNTIL YOU ARE TOLD TO DO SO**

Question 1

Briefly describe the main 8 joining methods for plastic products (25 marks)

Question 2

- a) State 4 drivers emphasizing the importance of Metrology to international trade? (4 marks)
- b) Describe with diagram the traceability chain (9 marks)
- c) A school ruler manufactured by a world class firm has a certified length of 30cm. Five groups of five students each are given the bearing to measure. The following are their results:

GROUP	Student 1	Student 2	Student 3	Student 4	Student 5
Group A	30.21	30.22	29.35	29.65	30.01
Group B	33.11	32.28	33.07	32.89	33.02
Group C	29.85	29.91	29.99	30.13	30.09
Group D	28.95	31.51	29.03	30.96	31.03
Group E	28.76	29.05	29.27	29.45	31.51

Question 3

- a) What is Forging and its major operation types? (5 marks)
- b) What is Rolling and its major operation types? (5 marks)
- c) Describe with diagrams the 5 typical types of rolling mill classifications. (15 marks)
  - i) Which group is least accurate? (3 marks)
  - ii) Which group has smallest error? (3 marks)
  - iii) Which group is least precise? (3 marks)
  - iv) Which group has least uncertainty? (3 marks)

Question 4

- a) State the six basic factors in casting (6 marks)
- b) What is the most suitable casting method for complex castings (3 marks)
- c) Briefly describe with diagrams 4 common casting quality defects associated with sand casting. (16 marks)

Question 5

- a) List the 7 codes used for classifying plastics and give examples of their application. (21 marks)
- b) List 8 typical additives used in plastics (4 marks)

---

END OF EXAMINATION



**THE UNIVERSITY OF ZAMBIA**  
**SCHOOL OF ENGINEERING**  
**DEPARTMENT OF MECHANICAL ENGINEERING**

**END OF YEAR EXAMINATIONS FOR THE 2020 ACADEMIC YEAR**  
**MEC 4601: FLUID MECHANICS II**

**TIME ALLOWED: THREE (3) HOURS**  
**CLOSED BOOK**

This question paper has four printed pages including this cover

---

**INSTRUCTIONS**

- 1. Answer a TOTAL of FIVE (5) Questions.**
  - 2. Each Question carries Twenty (20) marks.**
  - 3. State all assumptions and comment as much as possible on the fluid mechanics implications of the answers obtained.**
  - 4. Draw clear graphs and sketches where necessary.**
  - 5. Work with Algebraic expressions as far as possible before final computations.**
  - 6. Units (Metric) have to be used all the way through the answers. That is, all numbers where possible should have units.**
  - 7. Tie or staple the answer script in the upper left hand corner.**
-

### Question 1

- (a) Distinguish between “*multi stage*” and “*single stage*” pumps and give an application of each.
- (b) Give a well labelled *sketch* showing the connection of the main components required to pump water from a sump to an overhead tank. Briefly *explain the function* of each component.
- (c) Explain the *working principle* of a pump referring to the sketch you have drawn in part (b)
- (d) What is “*cavitation*” and how is it recognized in practice?

[4 + 8 + 6 + 2 = 20 Marks]

### Question 2

A projectile is launched from a certain location on the earth’s surface and travels in such a way that it experiences adiabatic supersonic flow through relatively still air until it successfully reaches its intended destination. The projectile is designed in such a way that it experiences stagnation points somewhere along its body.

- (a) Explain the term “*stagnation point*” for this projectile.
- (b) With the aid of a well labelled diagram explain the term “*supersonic flow*” for this body. Your answer must include; the zone of action, the zone of silence, the Mach angle and the Mach cone.
- (c) Given that the projectile motion is adiabatic, modify the standard Bernoulli’s equation to suit this type of process.

[2 + 8 + 10 = 20 Marks]

### Question 3

As a fluid mechanics specialist working in a lubrication testing laboratory, you have been requested to predict the flow characteristics of a lubricant flowing between two parallel plates as part of a research project.

- (a) Explain *Newton’s law of viscosity* in relation to the viscous flow of the lubricant between the parallel plates.
- (b) Using a suitable *sketch* show that the *velocity distribution* across the two plates is given by the expression below;

$$u = -\frac{1}{2\mu} \frac{\partial p}{\partial x} [ty - y^2]$$

- (c) From the sketch and expression given in part (b), obtain an expression for the *shear stress distribution* in the plate section,
- (d) Using a suitable *sketch*, show the *velocity and stress distributions* in a plate cross section.

[3 + 10 + 5 + 2 = 20 Marks]

#### Question 4

At a beverage production plant, a *hydrodynamically smooth* pipe is used to carry water at the rate of 360 l/s and temperature of 23°C.

- (a) Explain Prandtl's mixing length theory and give an expression of the total shear stress experienced in the smooth pipe.
- (b) If the head loss in 120m of pipe is not to exceed 4m, determine the pipe diameter.

$$\text{Given: } (\rho = 1000 \text{ kg/m}^3, \nu = 10^{-6} \text{ m}^2/\text{s}, f = 0.0032 + \frac{0.221}{(Re)^{0.237}}, h_f =$$

$$\frac{fLV^2}{D \times 2g} \text{ and } Re = \frac{\rho VD}{\mu})$$

[8 + 12 = 20 marks]

#### Question 5

An oil of viscosity 0.9 Ns/m<sup>2</sup> is to be transported from one point of an oil processing plant to the next point, the diameter of the pipe is given as 80 mm. If the pressure drop in 105 m length of the pipe is calculated as 2000 kN/m<sup>2</sup>, with your knowledge and understanding of fluid mechanics, answer the following questions.

- (a) Define the dynamic viscosity and kinematic viscosity of this oil.
- (b) Assuming that the type of flow in the pipe is viscous, show that the viscosity together with the relative velocity cause a shear stress to act between the fluid layers as shown in the relation below.
- (c) Given the specific gravity of the oil as 0.9, calculate the following:-
- The rate of flow of the oil
  - The centerline velocity
  - The total frictional drag over 105 m length
  - The power required to maintain the flow
  - The velocity gradient at the pipe wall
  - The velocity and shear stress at 8 mm from the wall

[2 + 4 + 14 = 20]

### **Question 6**

At a newly constructed power generation plant, a single jet Pelton turbine is required to develop 11000 KW. The available head at the nozzle is 800m. assuming an electric generation efficiency of 90%, a Pelton wheel efficiency of 88%, the coefficient of velocity for the nozzle 0.97, mean bucket velocity 0.47 percent of jet velocity, outlet angle of the buckets  $16^\circ$  and the relative velocity of the water leaving the buckets 0.87 of that at the inlet, calculate;

- (i) The flow
- (ii) The jet diameter
- (iii) The force exerted by the jet on the buckets
- (iv) The rotational speed if the ratio of the mean bucket circle diameter to the jet diameter is not less than 10.

[20 Marks]

### **Question 7**

A centrifugal pump is to be installed to supply water to an apartment building with a maximum height of 200m. The impeller has a diameter of 400mm and a width of 200mm at inlet and the corresponding dimensions at the outlet are 800 and 100mm respectively, the rotational speed of the pump is 1400rpm. The blades of the impeller are curved backwards at  $30^\circ$  to the tangent at exit, if the discharge is given as  $0.4\text{m}^3/\text{s}$ , determine;

- (i) The theoretical head developed
- (ii) The manometric efficiency
- (iii) The pressure rise across the impeller assuming losses equal to 12 percent of the velocity head at exit
- (iv) The pressure rise and the loss of head in the volute casing
- (v) The vane angle at inlet
- (vi) The power required to drive the pump assuming overall efficiency of 70%. What would be the corresponding mechanical efficiency?

[20 Marks]

---

**END OF MEC 4601 – FLUID MECHANICS II END OF YEAR FINAL EXAMINATION -  
DECEMBER 2021**

**Prepared By: M. M. Mwaba**