

THE UNIVERSITY OF ZAMBIA

SCHOOL OF MINES

SECOND SEMESTER EXAMINATION 2009

1. GG 202 EARTH RESOURCES AND ENVIRONMENT
2. GG 219 MINING GEOLOGY
3. GG 312 PETROLOGY (PAPER 1-THEORY)
4. GG 312 PETROLOGY (PAPER 2-PRACTICAL)
5. GG 322 STRATIGRAPHY AND PALEAONTOLOGY (PAPER 1-THEORY)
6. GG 322 STRATIGRAPHY AND PALEAONTOLOGY (PAPER 2-PRACTICAL)
7. GG 332 REMOTE SENSING GEOGRAPHIC INFORMATION SYSTEMS
8. GG 402 GEOLOGY OF ZAMBIA
9. GG 412 METAMORPHIC PETROLOGY (PAPER 1-THEORY)
10. GG 412 METAMORPHIC PETROLOGY (PAPER 2-PRACTICAL)
11. GG 442 GEOLOGY OF METALLIFEROUS MINERAL DEPOSITS (PAPER 1-THEORY)
12. GG 442 ECONOMIC GEOLOGY OF METALLIFEROUS MINERAL DEPOSITS (PAPER 2-PRACTICAL)
13. GG 472 APPLIED GEOCHEMISTRY (PAPER 1-THEORY)
14. GG 472 APPLIED GEOCHEMISTRY (PAPER 2-PRACTICAL)
15. GG 542 GEOLOGY OF NON-METALLIFEROUS MINERAL DEPOSITS
16. GG 572 HYDROGEOLOGY
17. MG 319 COMPUTER TECHNIQUES
18. MI 312 BLASTING
19. MI 331 UNDERGROUND MINING
20. MI 335 SURFACE MINING
21. MI 515 ROCK MECHANICS 2
22. MI 535 COAL MINING METHODS
23. MI 565 MINERAL ECONOMIC 2
24. MM 205 INTRODUCTION TO MINERAL SCIENCES
25. MM 332 CHEMICAL THERMODYNAMICS 2
26. MM 352 HEAT AND MASS TRANSFER
27. MM 442 PHYSICAL METALLURGY 2
28. MM 452 HYDROMETALLURGY
29. MM 452 PROCESS CONTROL AND INSTRUMENTATION
30. MM 542 FUELS, FINANCE AND REFRACTORIES

31.MM 552
32.MM 562

PROCESSING DESIGN
FOUNDRY

31.MM 552

PROCESSING DESIGN

32.MM 562

FOUNDRY



THE UNIVERSITY OF ZAMBIA

SECOND SEMESTER UNIVERSITY EXAMINATIONS – APRIL 2010

GG 202 – EARTH RESOURCES AND ENVIRONMENT

INSTRUCTIONS: ANSWER ANY 5 QUESTIONS USING SKETCHES
WHEREVER POSSIBLE.

TIME: THREE (3) HOURS

Q1. Define the following: (20 marks)

- (a) Natural resource
- (b) Abiotic natural resource
- (c) Actual natural resource
- (d) Renewable natural resource
- (e) Natural System
- (f) Cryosphere
- (g) Anthrosphere
- (h) Photosynthesis
- (i) Soil
- (j) Arable land

Q2. (a) Give three reasons why you think land is important. (3 marks)
(b) Interactions among the Earth systems cause many outcomes (i.e. both positive and negative). State 5 positive and 5 negative outcomes. (5 marks)
(c) Write short notes on atmosphere, hydrosphere, lithosphere and biosphere (12 marks)

Q3. (a) Explain how mechanical, biological and chemical weathering contribute to soil development (9 marks)
(b) In Lusaka, land is becoming so scarce that even where to bury our loved ones is increasingly becoming difficult. Can you give 5 reasons why this is so. (5 marks)
(c) What is landuse? (2 marks)
(d) If you were given an assignment to study landuse change in Lusaka north. What resource would you use and why? (4 marks)

- (a) Why are copper/cobalt deposits in Zambia regarded as a wasting asset? (3 marks)
- (b) What are fossil fuels (give three common examples) and how are they believed to have formed? (8 marks)
- (c) Tar-sands and oil shale are potential sources of energy. Why are these resources currently not being exploited? (2 marks)
- (d) Uranium is used as a nuclear energy source. This form of energy is cleaner and requires little raw material to generate huge amounts energy in comparison to fossil fuels and yet it is not commonly exploited. Discuss some of its problems. (7 marks)
- (a) What is water? (2 marks)
- (b) State five key uses of water. (5 marks)
- (c) There is a lot of water on Earth and most of it is not usable, why, how can we convert it to useful water and why is this not being done on large scale. (3 marks)
- (d) What is groundwater and how can we access it? (3 marks)
- (e) What is water stress and name five of its causes. (7 marks)
- (a) State five renewable forms of energy. (5 marks)
- (b) Briefly describe how four of these energies are generated. (8 marks)
- (c) How is each one of the four described in (b) linked to geology? (4 marks)
- (d) What is a biotic resource and give one example of biotic resources. (3 marks)

Discuss two positive and two negative impacts associated with exploitation and use of the following resources: (20 marks)

- (a) Mineral resources e.g. Copper Mining in Zambia
- (b) Biotic resources
- (c) Fossil fuels
- (d) Soils

END OF EXAMINATION

- Q4. (a) Why are copper/cobalt deposits in Zambia regarded as a wasting asset? (3 marks)
- (b) What are fossil fuels (give three common examples) and how are they believed to have formed? (8 marks)
- (c) Tar-sands and oil shale are potential sources of energy. Why are these resources currently not being exploited? (2 marks)
- (d) Uranium is used as a nuclear energy source. This form of energy is cleaner and requires little raw material to generate huge amounts energy in comparison to fossil fuels and yet it is not commonly exploited. Discuss some of its problems. (7 marks)
- Q5. (a) What is water? (2 marks)
- (b) State five key uses of water. (5 marks)
- (c) There is a lot of water on Earth and most of it is not usable, why, how can we convert it to useful water and why is this not being done on large scale. (3 marks)
- (d) What is groundwater and how can we access it? (3 marks)
- (e) What is water stress and name five of its causes. (7 marks)
- Q6. (a) State five renewable forms of energy. (5 marks)
- (b) Briefly describe how four of these energies are generated. (8 marks)
- (c) How is each one of the four described in (b) linked to geology? (4 marks)
- (d) What is a biotic resource and give one example of biotic resources. (3 marks)
- Q7. Discuss two positive and two negative impacts associated with exploitation and use of the following resources: (20 marks)
- (a) Mineral resources e.g. Copper Mining in Zambia
- (b) Biotic resources
- (c) Fossil fuels
- (d) Soils

END OF EXAMINATION

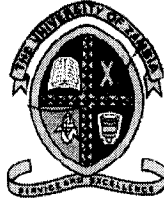

THE UNIVERSITY OF ZAMBIA

SECOND SEMESTER UNIVERSITY EXAMINATIONS – APRIL 2010

GG 219 – MINING GEOLOGY

INSTRUCTIONS: ANSWER ANY 5 QUESTIONS USING SKETCHES WHEREVER POSSIBLE.

TIME: THREE (3) HOURS

- Q1. (a) Define the Law of Uniformitarianism. (6 marks)
- (b) Describe and explain each of the three processes that melt rock to form magma. (6 marks)
- (c) What do the terms felsic, intermediate, mafic and ultramafic mean? (3 marks)
- Q2. (a) Discuss the factors that control rock behavior during deformation. (5 marks)
- (b) Name the three main types of geological structures produced when rocks deform. Explain the type of behavior that each type of structures reflects. (5 marks)
- (c) In what tectonic environment(s) would you expect to find each of the structures? (10 marks)
- Q3. (a) How are minerals distinguished from other substances? (5 marks)
- (b) List and explain the physical properties of minerals most useful for identification. (5 marks)
- (c) List the rock-forming mineral groups. Why are they called “rock-forming”? (5 marks)
- (d) How would you differentiate a crystal of a diamond from a crystal of quartz? (5 marks)

- Q4. (a) List the four factors that cause and drive metamorphism. (5 marks)
- (b) Describe the two changes occurring during metamorphism of rocks. (5 marks)
- (c) Describe and name the succession of metamorphic rocks that form as shale experiences progressively higher grades of regional (dynamothermal) metamorphism. (5 marks)
- (d) What is a metamorphic facies? (5 marks)
- Q5. (a) Name the two categories of geological resources. (5 marks)
- (b) Explain the importance of magmatic differentiation in the formation of chromite deposits. (5 marks)
- (c) How are hydrothermal ore deposits formed? (5 marks)
- (d) Explain the importance of source rock, reservoir rock, cap rock and oil traps in the formation of petroleum and gas reserves. (5 marks)
- Q6. (a) List the four categories of sedimentary rocks. (5 marks)
- (b) In which ways are clastic sediments modified during transport? (5 marks)
- (c) Why are clay particles in suspension for longer period of time before being deposited? (5 marks)
- (d) Describe how loose clastic sediment becomes lithified to form hard rock. (5 marks)

END OF EXAMINATION



THE UNIVERSITY OF ZAMBIA

SECOND SEMSTER UNIVERSITY EXAMINATIONS – APRIL 2010

GG312 1 PETROLOGY

PAPER 1 - THEORY

INSTRUCTIONS: ANSWER ANY FIVE (5) QUESTIONS. ILLUSTRATE YOUR ANSWER WITH FIGURES, DIAGRAMS ETC WHEREVER POSSIBLE. ALL QUESTIONS CARRY EQUAL MARKS.
THREE (3) HOURS

- a) What is magma? Briefly give an account of the main constituents of magma.
b) Give a brief description of the main textures of sedimentary rocks.
- a) Outline the main characteristics of the granite family.
b) Write short notes on the following:
(i) Slate
(ii) Schist
(iii) Gneiss
(iv) Marble
- Define the following:
a) Porphyritic Texture
b) Dyke
c) Conglomerates
d) Cross Bedding
e) Foliation
- a) What are the main factors that control a metamorphic reaction? Briefly outline the role of each factor.
b) What are the major processes that are involved in the formation of Sedimentary rocks?
- a) Define metamorphism.
b) Briefly outline the composition of Sedimentary rocks.
- Write short notes on the following:
a) Diorite
b) Siltstone
c) Quartzite
d) Basalt
e) Arkose
f) Phyllites



THE UNIVERSITY OF ZAMBIA

SECOND SEMSTER UNIVERSITY EXAMINATIONS – APRIL 2010

GG312 1 PETROLOGY

PAPER 1 - THEORY

INSTRUCTIONS: ANSWER ANY FIVE (5) QUESTIONS. ILLUSTRATE YOUR ANSWER WITH FIGURES, DIAGRAMS ETC WHEREVER POSSIBLE. ALL QUESTIONS CARRY EQUAL MARKS.
TIME: THREE (3) HOURS

- (a) What is magma? Briefly give an account of the main constituents of magma.
- (b) Give a brief description of the main textures of sedimentary rocks.

- (a) Outline the main characteristics of the granite family.
- (b) Write short notes on the following:
 - (i) Slate
 - (ii) Schist
 - (iii) Gneiss
 - (iv) Marble

Define the following:

- (a) Porphyritic Texture
- (b) Dyke
- (c) Conglomerates
- (d) Cross Bedding
- (e) Foliation

- (a) What are the main factors that control a metamorphic reaction? Briefly outline the role of each factor.
- (b) What are the major processes that are involved in the formation of Sedimentary rocks?
 - (a) Define metamorphism.
 - (b) Briefly outline the composition of Sedimentary rocks.

Write short notes on the following:

- (a) Diorite
- (b) Siltstone
- (c) Quartzite
- (d) Basalt
- (e) Arkose
- (f) Phyllites

7. Compare and contrast igneous rocks and metamorphic rocks with regard to:
- (a) State of matter involved (solid, liquid, gas)
 - (b) Texture
 - (c) Chemical composition

END OF EXAMINATION



THE UNIVERSITY OF ZAMBIA

SECOND SEMESTER UNIVERSITY EXAMINATIONS – APRIL 2010

GG312 – PETROLOGY

PAPER II - PRACTICAL

INSTRUCTIONS: ANSWER ALL QUESTIONS
TIME: TWO (2) HOURS

- Q1. You are provided with rock handspecimens 1,2,3,4,5 & 6, do the following:
- (a) Identify the minerals;
 - (b) Describe the texture(s); and
 - (c) Name the rock.
- Q2. You are provided with thin sections A & B, do the following:
- (a) Identify the minerals present;
 - (b) Discuss the texture(s); and
 - (c) Name the rock.

END OF EXAMINATION



THE UNIVERSITY OF ZAMBIA

SECOND SEMESTER UNIVERSITY EXAMINATIONS – APRIL 2010

GG322 – STRATIGRAPHY AND PALEAONTOLOGY

PAPER I – THEORY

INSTRUCTIONS: Answer any five questions using sketches wherever possible. All questions carry equal marks.

TIME: Three (3) Hours

- Q1. (a) In biostratigraphy, discuss three possible reasons for the disappearance of species in a particular stratigraphic section.
- (b) Explain each of the three main categories of stratigraphic classification.
- (c) Describe briefly the following: (i) angular unconformity, (ii) paraconformity, and (iii) disconformity.
- (d) Write short notes on two types of gradational sedimentary contacts stating the environments of deposition that are characteristic for each of them.
- Q2. (a) Discuss briefly the term Paleaoecology.
- (b) Explain why Paleaoecology is considered to be an incomplete science.
- (c) Define the following terms: (i) Stratigraphy, (ii) Sedimentary rock.
- (d) Describe transgression and regression and their impact on coastal sediments pile.
- Q3. (a) Define the following terms: (i) bed, (ii) bedding plane, and (iii) band,
- (b) Explain what a composite bed set is and what it represents in terms of environment of deposition.
- (c) Discuss the conditions that would lead to the deposition of a laminated *rock formation*.
- (d) Discuss the three ways in which beds terminate laterally.
- Q4. (a) Explain how the following affect sedimentation patterns in coastal areas: (i) climate, and (ii) tectonism.
- (b) Discuss briefly eustatic sea level changes and what causes them.
- (c) Describe two ways of correlating rocks of two different localities.
- (d) Briefly explain the term biofacies and its significance in paleo-basin analysis.

- Q5. (a) Write short notes that would explain the principles of Paleontology.
(b) Name any three modes of preservation of soft parts of fossils.
(c) If the environment of deposition of an area progressively and slowly changes over a period of time, a number of aspects are expected in relation to the sediment pile and the fossil record of the resulting rocks. Discuss three such aspects in regards fossil record.
- Q6. (a) Describe how biostratigraphy and lithostratigraphy are independent of each other.
(b) Describe how fossil record of same species appearing in rocks of adjacent areas may not represent correct age correlation.
(c) Discuss the evolution of a basin that would lead to dichronous deposition of a particular lithological unit.
(d) Explain what kind of depositional conditions would lead to: (i) sharp contacts in conformable beds, (ii) cyclic bedding, and (iii) fining upwards.
- Q7. (a) Briefly explain the term **Sequence Stratigraphy**.
(b) In Sequence stratigraphy, what does the term accommodation mean? Explain how this affects the sediment pile.
(c) Discuss the full cycle of events that would lead to a depositional sequence in a depositional environment.
(d) What organisms are believed to represent the oldest life on Earth? How old are these?

END OF EXAMINATION



THE UNIVERSITY OF ZAMBIA

SECOND SEMESTER UNIVERSITY EXAMINATIONS – APRIL 2010

GG322 – STRATIGRAPHY AND PALEAONTOLOGY

PAPER II – PRACTICAL

INSTRUCTIONS: Answer all questions.

TIME: Three (3) Hours

Two short boreholes, TXZ 1 and TXZ2, were drilled for geotechnical studies about 500 metres apart. The cores from both bore holes were logged and the logging information is given below. The collar elevations of both boreholes are considered to be the same. You are asked to do the following:

- (1) Make stratigraphic logs of both cores, using the standard format available. (30 marks);
- (2) Draw a neat and clear cross section that represents the sub-surface geology of the area that lies between the two boreholes. (30 marks);
- (3) Discuss, with good reasons, the possible depositional environment of the rocks intersected by the boreholes. (25 marks); and
- (4) Comment on the possible reasons for the absence of mudstone at the base of borehole TXZ 1. (15 marks)

Log: TXZ 1

0-2m	Very fine-grained mudstone, in places with shaly partings, desiccation cracks and root traces;
2-5m	Very fine- to medium-grained sandstone, horizontal bedding and locally massive;
5-10m	Coarse-grained to pebbly sandstone, trough cross-bedding alternating with planar x-beds;
10-16m	Matrix supported conglomerates, massive with crude bedding locally horizontal bedding;
16-19m	Clast-supported conglomerates, complex bed forms with tabular sheets;
19-21m	Pebbly sandstones, trough cross-bedding;
21- 24m	Very coarse grained sandstone, trough cross-bedded to parallel laminated;
24-25m	Medium-grained sandstone, ripple cross-laminated;
25-27m	Alternating mudstone and very fine-grained sandstone with an erosional contact at the base with an undifferentiated rock;

Log: TXZ 2

0-2m	Mudstone, in places with intraclasts, massive beds, desiccation cracks;
2-5m	Medium to coarse grained sandstone, horizontal bedding;
5-7m	Clast-supported conglomerates – mainly cobbles, complex bed forms with tabular sheets;
7-15m	Matrix supported conglomerates – mainly pebbles, massive with crude bedding locally horizontal bedding;
15-20m	Very fine-to medium-grained sandstone, horizontal bedding and locally massive;
20-23m	Mudstone, in places with shaly partings, thinly laminated overlain by massive beds; bioturbated with root traces;
23-24.5m	Undifferentiated metasediments

END OF EXAMINATION



THE UNIVERSITY OF ZAMBIA

SECOND SEMESTER UNIVERSITY EXAMINATIONS – APRIL 2010

GG332 - REMOTE SENSING AND GEOGRAPHIC INFORMATION SYSTEM

INSTRUCTIONS: ANSWER ANY FIVE (5) QUESTIONS. ALL QUESTIONS CARRY EQUAL MARKS (WILL BE MARKED OUT OF 20 MARKS). NEATLY DRAWN SKETCHES/ DIAGRAMS RECOMMENDED FOR A FULL MARK.

TIME: THREE (3) HOURS

- Q1. (a) What do following abbreviations stand for?
- (i) TIR(1 mark)
 - (ii) UV..... (1 mark)
 - (iii) EMR.....(1 mark)
 - (iv) NDVI.....(1 mark)
 - (v) DEM..... (1 mark)
- (b) Differentiate between the following:
- (i) Radiometric Resolution and Spectral Resolution.....(4 marks)
 - (ii) Band Sequential (BSQ) and Band Interleaved (BIL)(4 marks)
 - (iii) Path and Samples.....(4 marks)
 - (iv) False Colour Composite and True Colour Composite....(4 marks)
 - (v) Coordinates and Attributes(4 marks)
- Q2. With neatly labeled sketches or diagrams, **EXPLAIN** difference between the following:
- (i) Vector Model and Raster Model (8 marks)
 - (ii) Scattering and Reflection (8 marks)
 - (iii) Atmospheric Blind and Atmospheric Window (8 marks)
 - (iv) Passive and Active Sensors (8 marks)
 - (iv) Real-time and Post-processing differential corrections applicable to GPS.....(8 marks)
- Q 3. You have just been hired to work for Science and Technology Council of Zambia. The Council would like to introduce Remote Sensing in Zambia and your task is to convince the Chief Executive Officer (CEO) of the Council to buy in this new emerging technology. The CEO has requested you to outline the following:
- (a) The value of Remote Sensing to Zambia.....(10 marks)
 - (b) The value of GIS to Zambia.....(6 marks)

- (c) The value of GPS..... (6 marks)
 - (d) The data sources i.e. various forms of data that you could enter into a GIS project..... (8 marks)
- Q4. (a) What is a model in GIS, and define their characteristics.....(10 marks)
- (b) List the advantages for having a Polar Orbiting Earth Resources satellite.
.....(6 marks)
- (c) What does a Digital Image Data File consists of.....(5 marks)
- (d) Outline the anatomy of a GIS..... (6 marks)
- Q5. (a) Briefly describe the procedure one will use to be able to obtain a stereovision i.e. able to see the objects in three dimensions.....(6 marks)
- (b) In satellite image interpretation, a number of imagery recognition elements are used. Explain these elements.....(20 marks)
- Q6. (a) Define the following terms:
- (i) Shape files.....(2 marks)
 - (ii) Datum(2 marks)
 - (iii) ArcMap..... (2 marks)
 - (iv) Coverage..... (2 marks)
 - (v) Geoid..... (2 marks)
- (b) Give the Spatial Resolution of the Following:
- (i) Landsat TM Multi-spectral system..... (1 mark)
 - (ii) Quickbird Multi-spectral..... (1 mark)
 - (iii) SPOT Panchromatic (1 mark)
- (c) Give the components of a Geographic Coordinate System..... (3 marks)
- (d) Give the Wavelength of Blue, Green and Red Light. What is the name given to these Bands in Remote Sensing?(4 marks)
- Q7. (a) Outline the advantages of manual map digitizing.....(8 marks)
- (b) What steps should you take when digitizing – List them.....(7 marks)
- (c) Give a formula for the spectral fingerprint of a target..... (2 marks)
- (d) Using GPS Data in ArcGIS, what softwares did you use in order to bring your data in ArcGIS..... (2 marks)
- (e) Differentiate between Database and Database Management Systems
.....(4 marks)

END OF EXAMINATION



THE UNIVERSITY OF ZAMBIA

SECOND SEMESTER UNIVERSITY EXAMINATIONS – APRIL 2010

GG402 – GEOLOGY OF ZAMBIA

INSTRUCTIONS: Answer any four questions using sketches wherever possible. All questions carry equal marks.

TIME: Three (3) Hours

- Q1. The Lufilian fold belt is an example of a Neoproterozoic orogenic belt which has been interpreted using either the ensialic or modern-day plate tectonics.
- (a) What do you understand by the term orogenic belt and how does it differ from mobile belt?
 - (b) Describe the main features that suggest that the Katangan sedimentary rocks were formed in a rift setting.
 - (c) Discuss the main evidence which has been used to postulate large-scale thrusting in the Lufilian belt and briefly discuss why the identification of these thrust units is of importance.
- Q2. The Bangweulu Block is one of the major geotectonic units in Zambia.
- (a) During which geological time period did the Bangweulu Block form?
 - (b) Discuss the geological evolution of the Bangweulu Block using the geological age data of rock units given below.

ROCK UNIT	AGE (Ma)	86Sr/87Sr INITIAL RATIO
Mambwe granodiorite	1869±40	0.7072
Mansa volcanics	1838±86	0.7016
Luchewe granite	1833±18	0.7033
Mansa granite	1816±22	0.7063
Lusenga syenite	1134±8	0.7042
Lwakwa granite	1108±43	0.7085
Mambwe dolerite	709±12	--
Songwe syenite	671±62	0.7058

- (c) How does the Bangweulu Block differ from a typical Archean craton?

- Q3. (a) Describe the lithostratigraphy of the Katanga Supergroup in Zambia.
(b) Discuss the mineralization in the Katangan orogen.
- Q4. Discuss the geological evolution of the Irumide Belt in terms of stratigraphy, sedimentation, deformation and magmatism.
- Q5. (a) Outline in form of a table the stratigraphy of the Phanerozoic in Zambia.
(b) Describe the geological setting of the Upper Karoo Group indicating its possible depositional environment and economic potential.
- Q6. (a) Name the formations of the Sinakumbe Group.
(b) Describe the oldest formation in (a) including its (i) stratigraphy and (ii) possible depositional environment.

END OF EXAMINATION



UNIVERSITY OF ZAMBIA

SECOND SEMSTER UNIVERSITY EXAMINATIONS – APRIL 2010

GG 412 - METAMORPHIC PETROLOGY

PAPER I THEORY

INSTRUCTIONS: ANSWER QUESTIONS ONE & TWO AND ANY OTHER THREE QUESTIONS. ILLUSTRATE YOUR ANSWER WITH FIGURES, DIAGRAMS WHEREVER POSSIBLE. ALL QUESTIONS CARRY EQUAL MARKS.

TIME: THREE (3) HOURS

- Q1. (a) Use chemical equations and diagrams to illustrate the four different types of chemical reactions that occur during metamorphism of rocks.
- (b) Indicate the positions of the fields of the principal metamorphic facies in the P-T space.
- (c) Discuss some of the reactions that are likely to take place during regional metamorphism of the argillaceous shale to form schists of low to intermediate grade.
- (d) Describe the metamorphic reactions that may take place during metamorphism of siliceous limestone.

Q2. Consider the reaction:

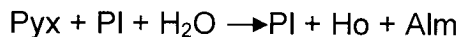

(Where Pyx = Pyroxene; Pl= plagioclase; Ho =hornblende; Alm = almandine)

- (a) What is the chemical type of rocks in this reaction?
- (b) Is this a continuous or discontinuous reaction? Why?
- (c) Draw your conclusion about the metamorphic facies

Q3. Compare and contrast metamorphic rocks and magmatic rocks with regard to:-

- (a) State of matter involved (liquid, solid, gas);
- (b) Texture; and
- (c) Chemical composition.

- Q4. Write short notes on the followings:
- (a) Gneisses;
 - (b) Metamorphic zones;
 - (c) Shock metamorphism; and
 - (d) Augen gneiss.
- Q5. Define a metamorphic facies. Discuss the main characteristics of the contact metamorphic facies.
- Q6. Briefly discuss the main criteria for naming metamorphic rocks.
- Q7. Classification schemes for metamorphism are based on several principle factors. Discuss how these factors are used to classify metamorphism.

END OF EXAMINATIONS



UNIVERSITY OF ZAMBIA

SECOND SEMESTER UNIVERSITY EXAMINATIONS – APRIL 2010

GG 412 - METAMORPHIC PETROLOGY

PAPER II - PRACTICAL

INSTRUCTIONS: ANSWER ALL QUESTIONS.

TIME: THREE (3) HOURS

- Q1. Give a full petrographic description of thin sections A and B, emphasize on the following: (60 marks)
- (a) Mineralogy
 - (b) Texture
 - (c) Chemical type
 - (d) Metamorphic grade
 - (e) Name the rock
- Q2. Figure 1 shows a map of a regional metamorphic terrain, characterised by a succession of isoclinals folded schists and gneisses. The various rock types of the area contain the following mineral assemblages: (40 marks)
- Rock type 1: quartz- calcite-tremolite-albite
- Rock type 2: calcite-quartz
- Rock type 3: quartz-biotite-muscovite-almandine; chlorite partially replaces biotite and almandine.
- Rock type 4a: quartz –plagioclase-hornblende
4b: quartz-plagioclase-hornblende-diopside
- Rock type 5: quartz-almandine-cordierite-sillimanite-biotite – alkali feldspar; chlorite partially replaces almandine.
- Rock type 6: mixed rock consisting of melanocratic, biotite-rich parts and leucocratic veins of granite composition.
- Rock type 7: granite

- (a) Discuss the metamorphic grade obtained in this terrain, taking into account that various chemical rock types present. Is there evidence for polymetamorphism?
- (b) What name would you give to the boundary between rock type 4a and rock type 4b?
- (c) Discuss the origin of Rock Type 6. Would the boundary between Rock Types 5 and 6 be gradational or sharp?

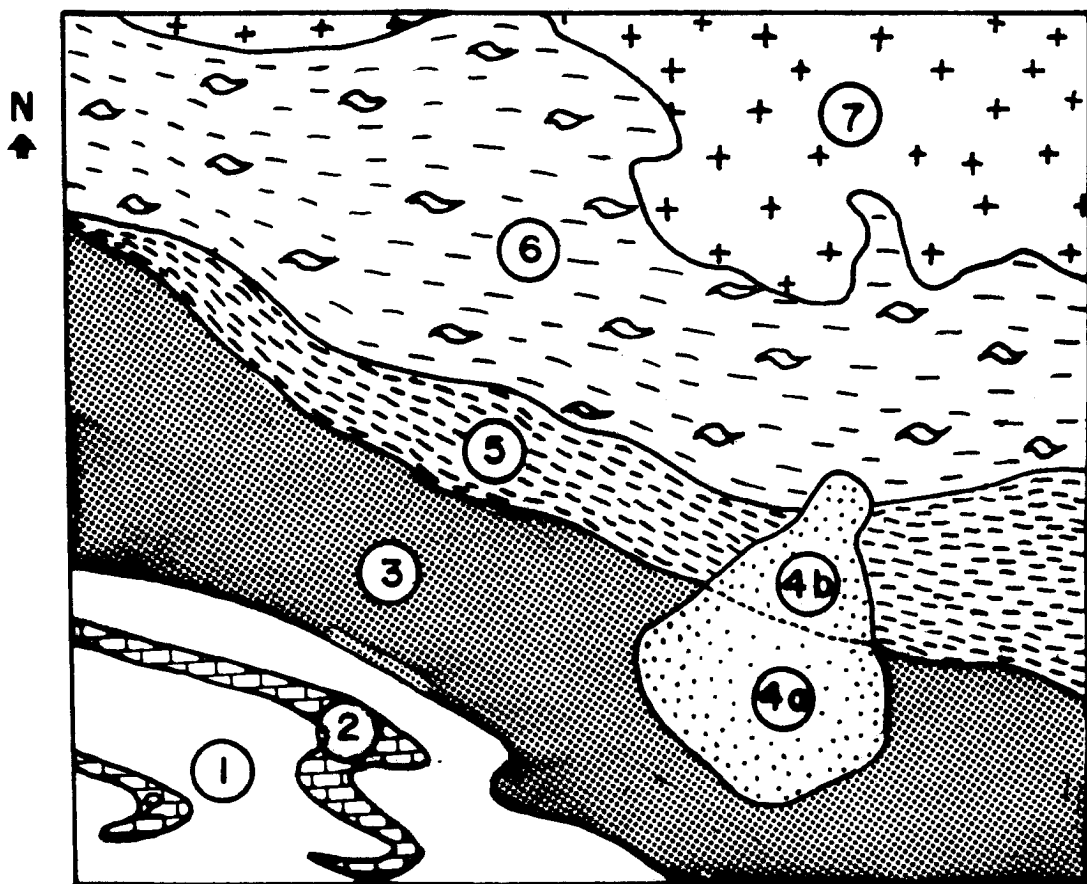

FIGURE 1



THE UNIVERSITY OF ZAMBIA

SECOND SEMESTER UNIVERSITY EXAMINATIONS – APRIL 2010

GG 442 – GEOLOGY OF METALIFEROUS MINERAL DEPOSITS

PAPER I - THEORY

INSTRUCTIONS: ANSWER ANY 5 QUESTIONS USING SKETCHES
WHEREVER POSSIBLE.

TIME: THREE (3) HOURS

- Q1. (a) Define the following terms: (10 marks)
- (i) Metallic mineral deposit
 - (ii) Ore
 - (iii) Cut-off-grade
 - (iv) Proven ore reserve
 - (v) Concentration factor
- (b) How does each of the following factors limit the availability of mineral resources? (10 marks)
- (i) Market forces
 - (ii) Engineering & environmental costs
 - (iii) Taxation
 - (iv) Land tenure
 - (v) Government legal policies
- Q2. (a) Describe briefly how mineralisation would form by the following processes and give one example deposit for each process: (10 marks)
- (i) Hydrothermal
 - (ii) Liquid immiscibility
 - (iii) Lateral secretion
 - (iv) Pyrometasomatism
 - (v) Mechanical accumulation
- (b) What four factors would cause the precipitation of ore minerals? (2 marks)
- (c) What is a fluid inclusion and what two parameters can be derived from fluid inclusions? (4 marks)
- (d) Distinguish primary fluid inclusions from secondary fluid inclusions. (4 marks)

- Q3. (a) Write short notes on the following: (12 marks)
- (i) Reflection pleochroism
 - (ii) Internal reflections
 - (iii) Cumulus textures
 - (iv) Exsolution textures
 - (v) Topotaxy replacement
 - (vi) Comb structure
- (b) Highlight the four important aspects of ore textures. (8 marks)
- Q4. (a) What is isotope fractionation? (2 marks)
- (b) Why are variations in isotopic composition of hydrogen, oxygen, carbon, and sulphur important in the study of ore-forming processes? (4 marks)
- (c) Given that $\alpha_{L-V}(O) = 1.0092$ & $\delta^{18}O_L = 0.0\%$, define the parameters in the equations below, determine $\delta^{18}O_V$ relative to SMOW and PDB and comment on the results. (12 marks)
- Equations are: $\alpha_{L-V} = (\delta^{18}O_L + 1000)/(\delta^{18}O_V + 1000)$ & $\delta^{18}O(\text{SMOW}) = 1.03086 * \delta^{18}O(\text{PDB}) + 30.86$; show all your calculations.
- (d) If a vein discordant to a copper-mineralised layer has been dated at 200Ma what would be the approximate age of the mineralisation and why? (2 marks)
- Q5. (a) Describe and discuss briefly how stratiform chromite deposits are believed to have formed paying attention to the source(s) of metals, transportation mechanism(s) and causes of deposition. (10 marks)
- (b) Describe and discuss briefly how porphyry copper deposits are believed to have formed paying attention to the source(s) of metals, transportation mechanism(s) and causes of deposition. (10 marks)
- Q6. (a) Briefly discuss the Zambian Copperbelt Deposits in terms of their tectonic setting, age, deformation and metamorphic features, main host lithologies, main ore minerals and their zonation, and origin of both metals and sediments. (15 marks)
- (b) Are the Zambian copper deposits strata-bound or stratiform? Why? (5 marks)
- Q7. (a) Define the following terms: (6 marks)
- (i) Epithermal Vein
 - (ii) Mesothermal Vein
 - (iii) Hypothermal Vein
- (b) How in general terms do veins form? (6 marks)
- (c) A vein deposit with copper mineralization has been discovered through exploration and needs to be evaluated. This vein deposit, containing quartz, pyrite and chalcopyrite, is vertical. Discuss the main features that the vein would acquire after oxidation has occurred and how these features are acquired. (8 marks)

END OF EXAMINATION



THE UNIVERSITY OF ZAMBIA

SECOND SEMESTER UNIVERSITY EXAMINATIONS – APRIL 2010

**GG442 – ECONOMIC GEOLOGY OF METALLIFEROUS MINERAL
DEPOSITS**

PAPER II – PRACTICAL

INSTRUCTIONS: ANSWER ALL QUESTIONS.

TIME: TWO & HALF HOURS

- Q1. Identify and describe ore minerals A, B, C, and D using their physical properties (colour, hardness, streak, lustre, cleavage, reaction to cold & dilute HCl). (20 marks)
- Q2. You are provided with two polished sections 1 and 2. Using the reflected light microscope identify the ore minerals present and describe the observed textures. Discuss the possible origin of the observed textures. (80 marks)

END OF EXAMINATION



THE UNIVERSITY OF ZAMBIA

SECOND SEMESTER UNIVERSITY EXAMINATIONS – APRIL 2010

GG 472 – APPLIED GEOCHEMISTRY

PAPER I – THEORY

INSTRUCTIONS: Answer any four questions. Use diagrams and equations wherever necessary. All the questions carry equal marks.

TIME: Three (3) Hours

Q1. Write short notes on the following concepts.

- (a) Associations of elements in mineral deposits.
- (b) Aqueous mobility of elements in the surficial environments.
- (c) Classification of the chemical elements on the basis of their toxicity.
- (d) Geochemical dispersion and classification of dispersion patterns.
- (e) Acid Mine Drainage

Q2. (a) Discuss the major factors that control the redox potential and acidity of natural waters in the surficial geochemical environments.
(b) Discuss the role of Eh, pH and adsorption on the mobility of Cu, Fe, Ni, Pb, U and Mn.

Q3. Construct an Eh-pH diagram for the system Pt-O-H at 25⁰C and 1 bar pressure.

<u>Species</u>	<u>ΔG_f^0(Kcal/gfw)</u>
H ₂ O (l)	-56.69
H ⁺ (aq)	0
Pt ²⁺ (aq)	+54.8
Pt(OH) ₂ (c)	-68.2
Pt (c)	0
PtO ₂ (c)	-20.0

Q4. Use the data and the equation given below to determine the state of saturation of the groundwater with respect to anhydrite.

<u>Constituent</u>	<u>Concentration(ppm)</u>	<u>species</u>	<u>ΔG_f^0(Kcal/gfw)</u>
Ca ²⁺	40	Ca ²⁺	-132.31
Mg ²⁺	22	SO ₄ ²⁻	-177.95
Na ⁺	0.4	CaSO ₄	-315.92
K ⁺	1.2		

SiO ₂	8.4
HCO ₃ ⁻	213
SO ₄ ²⁻	4.9
Cl ⁻	2.1

$$-\log \gamma = Az^2I^{1/2}$$

$$A=0.51$$

Q5. Discuss the processes and conditions that favour the development and preservation of bauxite deposits.

Q6. The chemical composition of the Munali Hills gabbro and its product of chemical weathering are given below. Use this data to answer the following questions.

- (a) Compare the mineralogy of the gabbro and the laterite.
 (b) Discuss the processes that have produced the laterite.

<u>Oxide</u>	<u>Gabbro</u>	<u>Laterite</u>
SiO ₂	50.4	5.24
TiO ₂	0.3	0.14
Al ₂ O ₃	17.4	1.73
Fe ₂ O ₃	2.7	88.48
FeO	8.3	0.95
MnO	0.07	0.01
MgO	4.7	0.23
CaO	8.7	0.15
Na ₂ O	4.0	0.12
K ₂ O	1.8	0.04
P ₂ O ₅	0.2	0.001
Cu	0.04	0.025
Ni	0.35	0.75
H ₂ O	0.95	3.01

END OF EXAMINATION



THE UNIVERSITY OF ZAMBIA
UNIVERSITY EXAMINATIONS – APRIL 2010
GG 472 – APPLIED GEOCHEMISTRY
PAPER II – PRACTICAL

INSTRUCTIONS: ANSWER ALL THE QUESTIONS. USE DIAGRAMS AND EQUATIONS WHEREVER NECESSARY. ENSURE THAT FIGURE 1 IS HANDED IN WITH THE ANSWER BOOKLET.

TIME: THREE (3) HOURS

Q1. Use the Eh-pH diagrams to discuss the geochemical barriers which the mine management may employ to control the mobility of heavy metals in the surface water at the following mining centres. (16 marks)

- (a) Munali Ni-Cu-Co-Pt mine.
- (b) Kabwe Pb-Zn mine.
- (c) Lumwana Cu-U mine.
- (d) Nchanga Cu-Co mine.

Q2. Discuss the quality of the water given in table 1 and the methods of treatment that may be employed to make the water suitable for human consumption. (20 marks)

Table 1. Composition of water (all units except for pH are in ppm)

Parameter	Surface water	Rainwater	Groundwater	Undergroundwater
pH	6.5	3.4	6.7	2.5
Total dissolved solids	5500	10	125	10200
Sulphate	20	5.2	30	6600
Ammonia	<0.01	<0.01	<0.01	<0.01
Nitrates	<0.01	<0.01	<0.01	<0.01
Chloride	3300	1.0	5.8	0.1
Fluoride	-	0.01	0.05	0.03
Mg	10	0.1	5.1	41
Ca	30	3.2	19	68
Zn	0.5	0.03	0.02	200
Cu	0.2	<0.001	<0.001	312
Na	2000	1.2	4.4	23
K	50	0.14	3.2	14

The results of a reconnaissance geochemical survey are shown in Figure 1 and Table 2. Use this data to answer the following questions. (40 marks)

- Discuss briefly the mineral potential of this area.
- Propose 3 sites for excavation of prospecting pits and trenches.
- Which elements would you use in a hydrogeochemical survey?
- Mark the positions of 10 sampling sites in Figure 1 for additional stream sediment samples and five sites for hydrogeochemical samples.

Table 2

S. NO	Sample Type	Fe (%)	Ni (ppm)	Cu (ppm)	Cr (ppm)	Co (ppm)
1a	Rock	12.03	2068	164	591	147
1b	Gossan	66.36	8020	423	20	5
1c	Rock	11.49	1972	201	632	149
1	Stream sediment	52.28	506	266	368	296
2	“	38.17	274	152	461	129
4	“	32.78	192	170	495	119
6	“	23.13	119	140	311	8
7	“	12.33	43	40	206	30
8	“	16.86	108	42	227	9
9	“	10.14	38	37	192	41
10	“	15.54	87	102	222	6
11	“	9.05	33	34	180	45
12	“	13.89	61	74	209	33
14	“	28.34	85	85	325	63

Q4. A summary of data obtained in a stream sediment survey for copper in St. John's Mission area is given below. Use an appropriate statistical technique to establish the presence or absence of copper anomalies in this area. (24 marks)

Analytical value (ppm)	Frequency
0	10
5	41
10	196
15	82
20	245
25	76
30	216
35	41
40	126
45	39
50	82
55	18
60	56

Analytical value (ppm)	Frequency
65	11
70	26
75	7
80	18
85	2
90	15
95	2
100	10
110	2
120	7
150	1
160	1
180	2
200	1
235	1
240	1
260	1
270	1

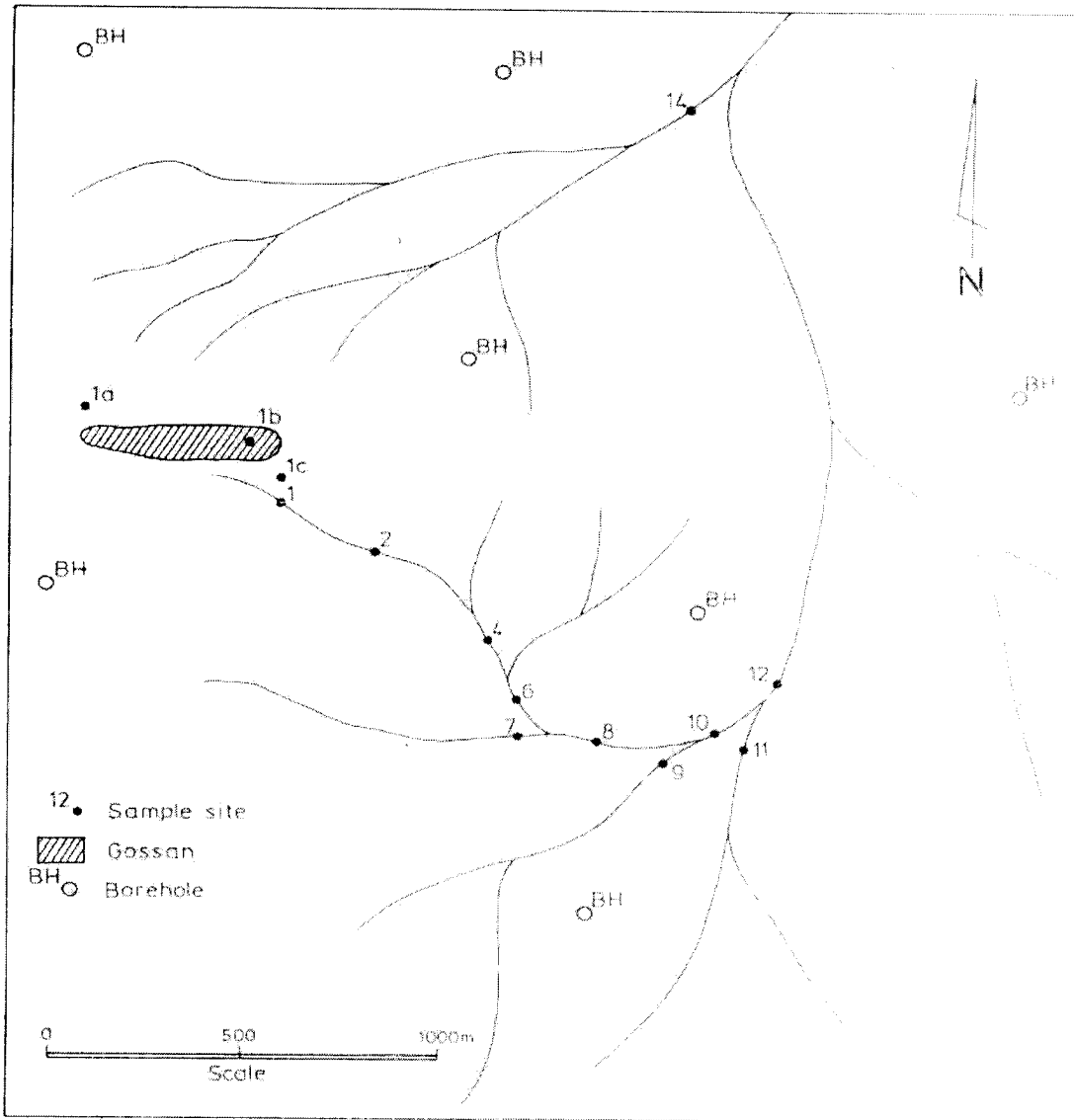

Figure 1

END OF EXAMINATION



THE UNIVERSITY OF ZAMBIA

SECOND SEMESTER UNIVERSITY EXAMINATIONS – APRIL 2010

GG 542 – GEOLOGY OF NON-METALIFEROUS MINERAL DEPOSITS

INSTRUCTIONS: ANSWER ANY 5 QUESTIONS USING SKETCHES
WHEREVER POSSIBLE.

TIME: THREE (3) HOURS

Q1. Define the following terms: (20 marks)

- (a) Measured Industrial Mineral Reserve
- (b) Roofing granules
- (c) Ceramic product
- (d) Plaster of Paris
- (e) Terrazzo
- (f) Cement-modified soil
- (g) Soil amendment
- (h) Consolidant
- (i) Wallboard
- (j) Acoustic insulation

Q2. Imagine you have undertaken a conducted tour of the cement production facility in Chilanga owned by Larfage, state and describe all the stages involved. Also indicate the raw materials and which rock ~~they~~ *each raw material* would be sourced from. (20 marks)

Q3. State any four products that the Uniturtle Industries Zambia Ltd plant manufactures and describe how they are produced. Also state the use(s) of each of the products and the main raw materials. (20 marks)

Q4. Discuss how each of the following factors would affect the distribution of the commercial plants for production of industrial minerals: (20 marks)

- (a) Geographic location
- (b) Labour rates
- (c) Political stability
- (d) Market demand
- (e) Price competitiveness

- Q5. (a) What is an abressive? (2 marks)
(b) State the five physical characteristics that should be considered when assessing an industrial mineral for abrasive raw material. (5 marks)
(c) Write short notes on bonded abrasives and coated abrasives. (8 marks)
(d) State the five uses of diamond as an abressive. (5 marks)
- Q6. (a) In stone monument conservation, surface sealers have a critical purpose to serve. What is a sealer and what is its main use in stone monument conservation? (4 marks)
(b) State the five efficiency characteristics that should be tested for in a material being considered as a sealant and why. (5 marks)
(c) What is aggregate? Name two rocks that could be mined for aggregate and why? (5marks)
(d) In relation to quality of road aggregate, describe the following factors: moisture content, ability to bond with bitumen and strength. (6 marks)
- Q7. (a) One of the scenarios in the exploration for industrial mineral deposits is undertaking a broad survey. Who should conduct such a survey, for what purpose, what is involved and what is the end result? (8 marks)
(b) Sketch a general flow chart that shows how a quality evaluation of a carbonate rock for chemical-grade limestone and for lime should be done. (12 marks)

END OF EXAMINATION



THE UNIVERSITY OF ZAMBIA

SECOND SEMESTER UNIVERSITY EXAMINATIONS – APRIL 2010

GG 572 – HYDROGEOLOGY

INSTRUCTIONS: ANSWER ANY 5 QUESTIONS USING SKETCHES WHEREVER POSSIBLE.

TIME: THREE (3) HOURS

- Q1. Describe the hydrogeological setting of the University of Zambia Great East Road Campus with particular reference to (20 marks):
- (a) Aquiclude(s)
 - (b) Soil(s)
 - (c) Aquifuge(s)
 - (d) Aquitard(s)
 - (e) Aquifer(s)
 - (f) Area(s) of possible lithological overturn
 - (g) High recharge area(s)
 - (h) Area(s) of thin Vadose zone
 - (i) Area(s) of possible high specific retention
 - (j) Area(s) of possible karsts
- Q2. A tracer such as calcium chloride can be used to determine hydraulic conductivity of an unconfined aquifer.
- (a) Explain how a Tracer Test is carried out. (10 marks)
 - (b) What are its limitations? (5 marks)
 - (c) A productive alluvial aquifer with a hydraulic conductivity of 100 metres per day has a head drop of 10 metres over one kilometer horizontal distance. Calculate the velocity of the natural groundwater movement. (5 marks)
- Q3. (a) Write down the differential equation in plane polar coordinates for unsteady radial flow to a well in a confined aquifer and define all the terms in the equation. (5 marks)
- (b) Assume that a well is replaced by a mathematical sink of constant strength and impose the boundary conditions that $h = h_0$ for $t = 0$ and h approaches h_0 as r approaches infinity for t greater than zero. Write down the solution to the differential equation, namely the NONEQUILIBRIUM or THEIS EQUATION, for the well. Define all the terms involved. (5 marks)

(c) What six (6) assumptions are made in the application of the equation in (b) above? In each case explain how realistic the assumption is. (10 marks)

Q4. (a) Describe the Hydrologic cycle. (10 marks)

(b) For each parameter in the cycle, name at least one field of science in which it is used. (10 marks)

Q5. (a) Describe the Cooper – Jacob Method for solution of the nonequilibrium equation, explaining any conditionalities. (10 marks)

(b) A plot of drawdown, s , versus logarithm of time, t , (since the start of pumping) of a given data, has the following information:

- (i) Well is penetrating a confined aquifer
- (ii) Uniform pumping rate, $Q = 2500$ cubic metres per day
- (iii) Observation well is 60 metres away
- (iv) $t_0 = 0.39$ min
- (v) Slope to the line has the following coordinates: (1.0min, 0.18m), (10.0min, 0.18m) and (10min, 0.58m)

From the information given above, determine transmissivity, T and Storage coefficient, S . (10 marks)

Q6. (a) Prepare a table showing waterborne diseases. Included in the table should be (10 marks):

- (i) Name of Waterborne Disease
- (ii) Causative Organism
- (iii) Source of Organism in Water
- (iv) Symptom of the Disease

- (b)
- (i) Define pathogen
 - (ii) Why are coliform bacteria considered a good indicator of pathogens?
 - (iii) What indicates a positive response in a fermentation tube?
 - (iv) When is the Confirmed Test run in testing drinking water supplies?
 - (v) Why is the detection of only one coliform colony not an indication of unsafe water?

(10 marks)

Q7. Describe with the aid of a flow-chart, the MULTIPLE-TUBE FERMENTATION METHOD of determining the number of coliform bacteria in a water sample. (20 marks)

END OF EXAMINATION

THE UNIVERSITY OF ZAMBIA

SCHOOL OF MINES

UNIVERSITY EXAMINATIONS – APRIL/MAY 2010

MG 319 – COMPUTER TECHNIQUES

TIME: THREE HOURS

ANSWER FIVE QUESTIONS. QUESTIONS 1 AND 5 ARE COMPULSORY.

1. The pipeline for transporting tailings from the concentrator to the tailings dam under some pressure P is shown in **Figure 1**. The pump is rated suitably to pump the tailings at not less than 2,500 MPa. Allowable pressure changes due to shock factors are established and suitable pipe constructions are installed to withstand various pressures (e.g. thickness of steel in relation to pressure load on pipe segment).

The pipe is installed with gadgetry to give feedback on the pressure gauges (G1, G2 and G3 respectively). It is necessary to maintain the rated pressures at every gauge to avoid pressure build-up in the pipe, which may cause it to rupture. All the information recorded by the gauges is routed back to the circuitry panel, which is the pressure control system (contains the programs that check continuously the build-up and fall of pressure at various points).

ASSUMPTIONS

- A. Values recorded by the pressure gauges, G1, G2 and G3, can be entered from the keyboard to simulate continuous monitoring through pressure gauges.
- B. The maximum pressure at G1 is not to exceed 3500 MPa.

You are required to do the following:

Write a program which will be used in the circuitry panel to control the pressures in this pipeline, paying attention to the maximum and minimum allowable pressures at each gauge with the following options.

- If all pressures are within range : output should be NORMAL
- If $P1 > P1_{max}$ and P1 and P2 are within range: output should be PLEASE CHECK PRESSURE FROM FEED PUMP
- If $P2 < P2_{min}$: output should be PLEASE CHECK PRESSURE AT GAUGE 2
- If $P1 < P_{min}$, $P2 < P2_{min}$ and $P2 < P3_{min}$: output should be SYSTEM FAILURE, PLEASE INSPECT PRESSURE SYSTEMS. [20]

HINT:

Identify the flow, the constraints and decide on what kind of statement you can use to write the program

2.

- a) Describe five primitive types found in java. Explain their uses and give an example of values each of them can hold. [5]
- b) Describe in detail five Math class functions in java. [5]
- c) What is a literal? Explain using an example. [5]
- d) Differentiate between the following:
 - i. System.out.print
 - ii. System.out.println [5]

3.

- a) What is variable initialization? [2]
- b) Give three examples of routines or subroutines found in a "System" class in java [3]
- c) In the main() routine you can find the word "public". Describe the importance of this word in Java programming. [5]

d) Explain the following terms as they are used in the Java programming language. [10]

- i. Interrupts
- ii. Polling
- iii. Asynchronous events
- iv. Thread
- v. Pre-emptive multitasking
- vi. Java bytecode
- vii. Polymorphism
- viii. Protocol
- ix. Syntax
- x. Identifier

4. (a) Define and name the main functions of the following terms: [3 marks each]

- (i) The Operating system
- (ii) The C.P.U
- (iii) The control Unit
- (iv) The A.L.U

(b) Once the necessary data and instructions are in memory, what four steps does the C.P.U perform for each instruction? [8]

5. (a) What are the main advantages of using a productivity software and mention the major categories of task-oriented software. [6]

(b) What are modern computers based on and give five (5) advantages of using this technology. How is a computer different from a calculator? [6]

(c) Define a microprocessor and the term volatile in the context of computer memory [4]

(d) Distinguish between RAM and ROM and describe how a personal computer can be used as a terminal. [4]

6. (a) Define a network operating system giving examples (3) of network operating systems used in various companies or institutions. [3]
- (b) Define and state the functions of the following terms: [1 mark each]
- (i) Translators
 - (ii) Assemblers
 - (iii) Interpreters
- (c) Convert from decimal to binary [1 mark each]
- (i) 0.3125
 - (ii) 0.9375
- (d) Convert from binary to decimal [1 mark each]
- (i) 0.11
 - (ii) 0.1101
- (e) Convert from Octal to Decimal [1 mark each]
- (i) 3526
 - (ii) 15311
- (f) Do the octal addition [2 marks each]
- (i) $27 + 53$
 - (ii) $46 + 675$
- (g) Do these Hex additions [2 marks each]
- (i) $D5F + 4AC$
 - (ii) $BCA + E23$

END OF EXAMINATION IN MG 319

CIRCUITRY PANNEL

To control pressure in the pipe, increase flow and shut down the pump system in case of extreme pressures both low and high. Connected to all pressure gauges.

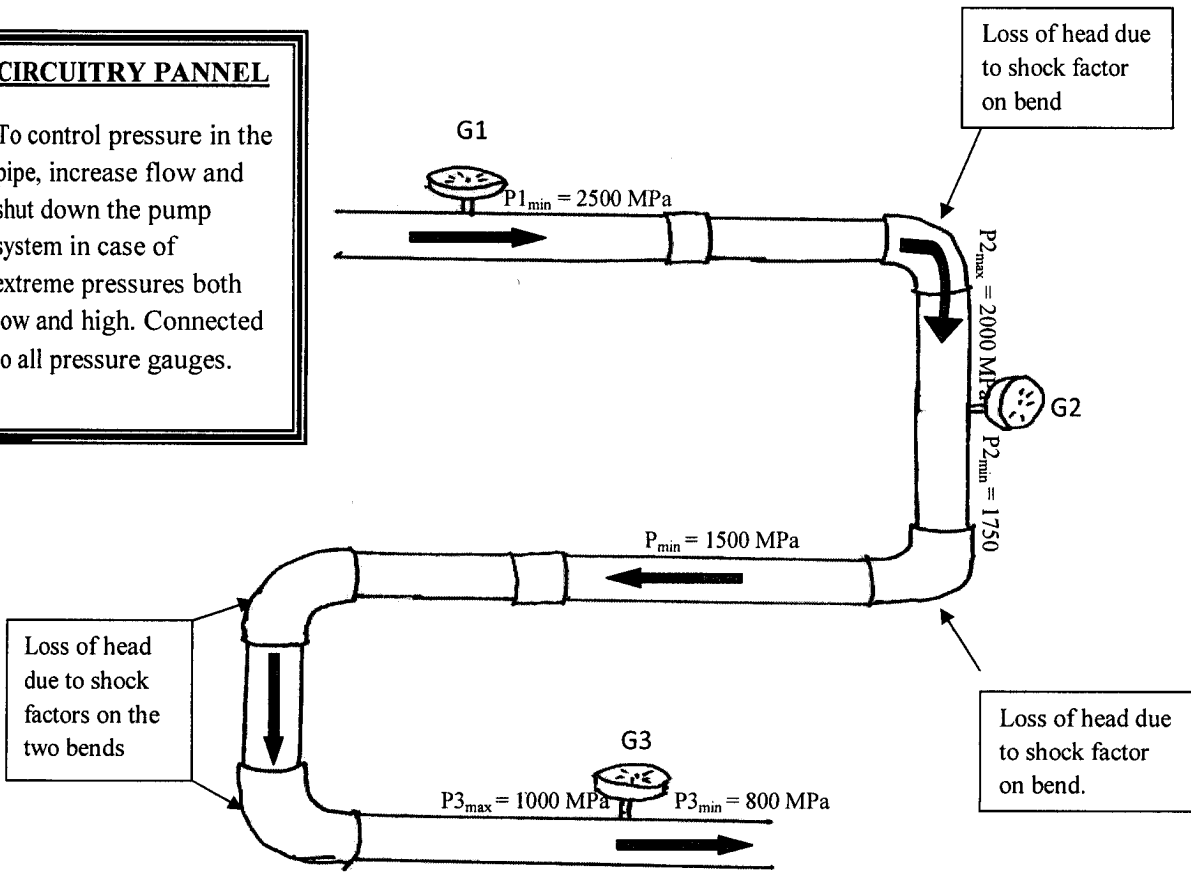

Figure 1.

THE UNIVERSITY OF ZAMBIA

MINING ENGINEERING DEPARTMENT

2010 SECOND SEMESTER UNIVERSITY EXAMINATIONS

MI 312-BLASTING

TIME: THREE HOURS

FULL MARKS: 100

INSTRUCTIONS: Answer Any 5 Questions

Question 1.

(a) List the main components of industrial explosives giving examples of where and how they find their best applications.....10 Marks.

(b) (i) Define Oxygen balance. What do you understand by a zero oxygen balanced mixture?.....4 Marks

(ii) Calculate the Oxygen Balance (OB) of Nitrodiglycol, given its chemical formular as:

$C_4H_8N_2O_7$4 Marks

Comment on the value of OB so calculated.....2 Marks

Total 20 Marks.

Question 2.

(a) Ammonium nitrate is an oxidiser and for each molecule of NH_4NO_3 . There is an excess of 1 atom of Oxygen. A variety of fuels could be used with Ammonium nitrate. Fuel Oil is cheap and easy to apply.

Calculate the percentages by weight of AN and FO of an ANFO mixture at zero Oxygen Balance.5 Marks

(b) Given the heats of formation below and bearing in mind that a mixture of AN and FO constitutes of C, H, N, O. A typical reaction would be:



Heat of formation: AN=87.2 kcal/mole
 Heat of formation of FO: 7.0 kcal/mole.
 Heat of formation: H₂O= 57.8kcal/mole
 Heat of formation :N= 0
 Heat of formation: CO₂= 94.05 kcal/mole.

Find the energy output of a zero oxygen balanced mixture of ANFO.....10 Marks

What would be the explosion temperature or the thermo chemical temperature given that the mean specific heat of the reaction C_v is = 0.33.....5 Marks.

Total 20 Marks

Question 3.

Explosive properties such as density, bulk density, water resistance, fume characteristics, exudation, strength and workability amongst others are extremely important in determining the suitability of explosives to be use in blasting operations.

Determine the main parameters of Ammon gelignite 74 , having the following characteristics:

- Cartridge size (diameter*length)= 25mm*200m
- Normal Cartridge count in 25Kg case=195
- Mass per meter run= 0.64kg/m
- Relative energy per unit length of hole= 125

You are required to determine the following specific parameters:

- (a) The mass of a single cartridge.....2 Marks
- (b) The explosive density.....2 Marks.
- (c) The relative Bulk Strength.....3 Marks
- (d) The relative weight strength.....3 Marks.
- (e) The absolute strength value.....3 Marks.
- (f) The relative workability.....3 Marks..
- (g) If the explosive had been loaded in blast holes of 38mm diameter what would be the charge density?.....4 Marks.

Use the Table of Indices provided for Question 3 on page 4

Total 20 Marks

Question 4.

- (a) Describe the full chain of initiation showing all the linkages in the initiation system as dictated by the blasting accessories used to achieve the detonation process. You are required to clearly indicate and make distinction between the deflagration and detonation links.....15 Marks

- (b) Describe with the aid of a sketch/diagram, the sequence of events in firing electric detonators.....5 Marks.

Total 20 Marks

Question 5.

- (a) Given the diagram of Bench Blasting on page 4, determine the required length of safety fuses to blast charges at the bench under the following conditions:
 - Number of charges..... $N=25$
 - Time to fire one charge and to shift to the next one..... $T_1=3$ seconds
 - Hole length..... $L=3$ m
 - Explosive, Ammon gelignite (60) ie the cartridge diameter is 32mm and its length is 200mm.
 - Number of cartridges in a hole
..... $M=111$
 - Retreat distance from the face to a place of safety..... $L_r=200$
 - Safety Fuse burning rate $R_f=100-200$ s/m.

15 Marks.

- (b) Calculate the volume of the amount of rock to be blasted by detonating the three blast holes as indicated in the diagram assuming that the rock has a density of 2.6 tonnes/m³5 Marks

Total 20 Marks

Question 6.

(a) Describe in detail:

(i) Any Blasting machine of the Generator type, highlighting where and how it finds its best use.....8 Marks

(ii) Any Blasting machine of the condenser type, highlighting where and how it finds its best use.....8 Marks.

(iii) Main power units for the firing of electric detonators in mines mentioning what precautions must be undertaken regarding their use.
4 Marks.

Total 20 Marks

Table for Question 3: Correlation between the explosive strength indices (AECI System)

Known value	Strength Index to be Calculated			
	Q	W	B	E
Absolute Strength Value Q	-	$\frac{Q \cdot 100}{Q_0}$	$\frac{Q \cdot \rho \cdot 100}{Q_0 \rho_0}$	$\frac{Q \cdot M \cdot 100}{Q_0 M_0}$
Relative weight strength W	$\frac{Q_0}{W \cdot 100}$	-	$\frac{\rho}{W \rho_0}$	$\frac{M_0}{W M_0}$
Relative bulk strength B	$\frac{B \rho_0 \cdot Q_0}{\rho \cdot 100}$	$\frac{B \cdot \rho_0}{\rho}$	-	$\frac{B \rho_0 \cdot M}{\rho M_0}$
Relative energy E	$\frac{E \cdot M_0 \cdot Q_0}{M \cdot 100}$	$\frac{E \cdot M_0}{M}$	$\frac{E \cdot M_0 \cdot \rho}{M \rho_0}$	

Key: $Q_0 = 3.8\text{MJ/kg}$
 $\rho_0 = 0.8\text{g/cc}$
 $M_0 = 0.709\text{kg/m}$

Bench Blasting Diagram for Question 5

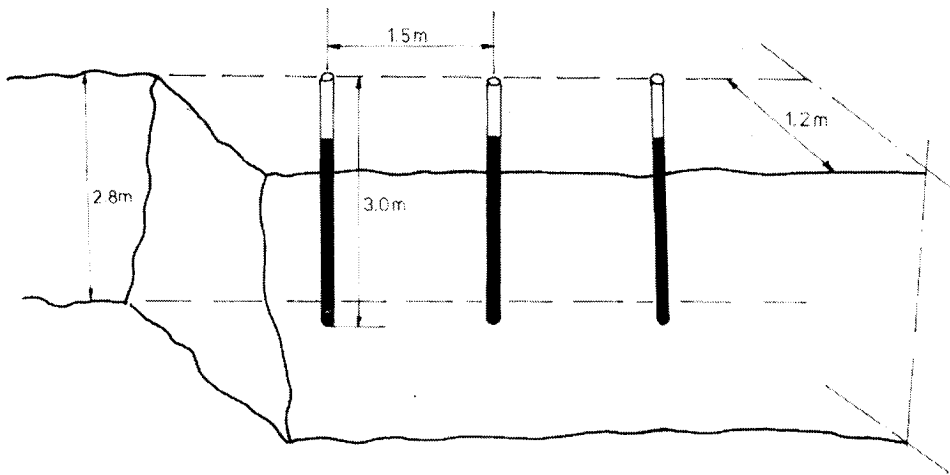

BASE LENGTH= 6.0m

END OF EXAMINATION

THE UNIVERSITY OF ZAMBIA
SECOND SEMESTER UNIVERSITY EXAMINATIONS

APRIL 2010 SEMESTER FINAL EXAMINATIONS

MI 331: UNDERGROUND MINING

TIME : THREE [3] HOURS FULL MARKS : 100

INSTRUCTIONS: ANSWER QUESTION 1 AND ANY OTHER 3. EACH QUESTION CARRIES 25 MARKS

QUESTION 1

a) Calculate the pillar width against factor of safety of 1.5 for the following conditions:

- Unit weight of overburden, γ , - $27 \frac{kN}{m^3}$
- Depth below surface, h - 250m
- Room width, R - 10m
- Pillar width, W - ?

Given that pillar strength, $\sigma_p = \sigma_1 (0.778 + 0.222 \frac{W}{H})$, where;

- Extraction height, H - 2.5m
- Pillar width, $W = ?$
- Strength of rock at mass size, $\sigma_1 = 24.3MPa$

[5 Marks]

b) Calculate the modified stability number, N , for the hangingwall surface of a stope

shown in Figure 1 given the following rock mass characteristics:

RQD = 90, $J_n = 4$, $J_r = 2$, $J_a = 1$, $\sigma_c = 100 MPa$ and $\sigma_1 = 5 MPa$

The stress factor, A , is calculated from the following ~~equations~~ ^{equations} ~~questions~~:

For $\frac{\sigma_c}{\sigma_1} < 2$, $A = 0.1$

For $\frac{\sigma_c}{\sigma_1} < \frac{10}{1}$, $A = 0.1125 \frac{\sigma_c}{\sigma_1} - 0.125$

For $\frac{\sigma_c}{\sigma_1} > \frac{10}{1}$, $A = 1$

[5 Marks]

Table 1: Showing Joint orientation

	Dip	Dip Direction
J_1	70^0	090
J_2	80^0	185
Lode	70^0	Strike N - S

- i. Given the slope height as 40m and using the calculated modified stability number, N, calculate the slope strike distance shown in Figure 1. [10 Marks]
- ii. For design in the supported transition zone, calculate the cable bolt density and number of bolts for 40m slope height and calculated strike distance [5 Marks]

NOTE: Figures for question 1 (one) are given as Figures 1, 2, 3, 4, 5 and 6 on pages 4 and 6.

QUESTION 2

- a) Clearly describe the variant of **block caving** used at Nchanga mine under the following headings:
 - i. Main characteristic features
 - ii. Sequence of development
 - iii. Layout of the ore pass, scraper drift, finger raises and trough drive
 - iv. Conditions suitable for its application [16 Marks]
- b) With the aid of clearly labelled diagram, explain the concept of flow ellipsoid as developed by Janel and Kvapil [9 Marks]

QUESTION 3

- a) Identify **eight (8) factors** that would influence the choice of a suitable mining method for extraction of a stratiform deposit [8 Marks]
- b) Clearly explain seven (7) main parameters used for characterisation of an ore body including typical range of values for each identified parameters, if any [7 marks]
- c) Answer the following questions using clear diagrams to show your working:
 - i. Calculate the **percentage recovery** from a portion of a panel in room and pillar **without** pillar extraction. Rooms are driven on 18m centers and crosscuts on a 24m centers but all openings are 6m in width. [5 Marks]
 - ii. Clearly show **five (5) different configurations** for the layout of development openings that can be used in opening up an ore deposit with the aid of suitable sketches [5 Marks]

QUESTION 4

With the aid of **clearly labelled sketches**, distinguish between **Shrinkage** and **Vertical Crater Retreat** mining methods under the following headings:

- i. Main characteristic features [5 Marks]
- ii. Sequence of development [5 Marks]
- iii. Conditions of application [5 Marks]

iv. Stopping process [5 Marks]

v. Ore extraction from the stopes (including filling of stopes) [5 Marks]

QUESTION 5

- a) Clearly explain ~~involved in ore~~^{how} ~~transportation~~^{is} from the stopes to the shaft ore bins and indicate all relevant equipment involved in the process [10 Marks]
- b) With the aid of a clearly annotated diagram, **describe** the shaft ore handling system commonly used for ore transfer from horizontal to vertical transport and clearly show the position of the haulage, shaft, crusher and loading pockets. [10 Marks]
- c) Show how an alternative ore handling system away from the shaft is arranged and linked to the skip. [5 Marks]
-

END OF EXAM

GOOD LUCK!!!

NOTE: Figures for Question 1

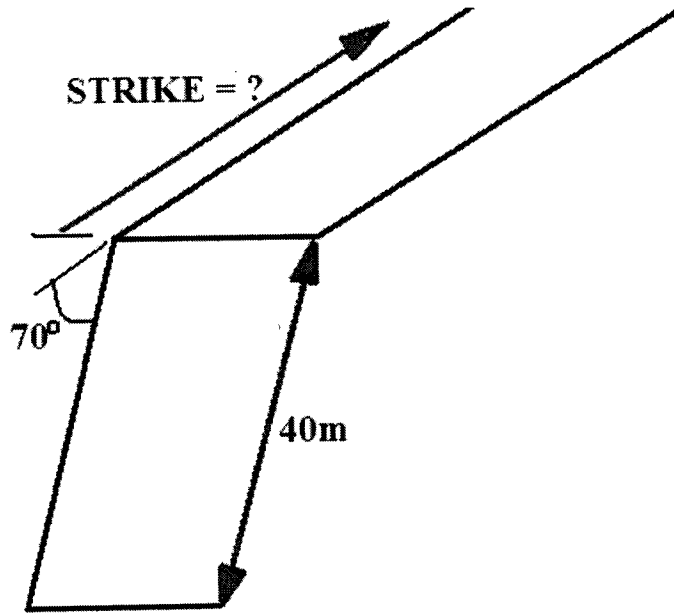

Figure 1: Slope design diagram

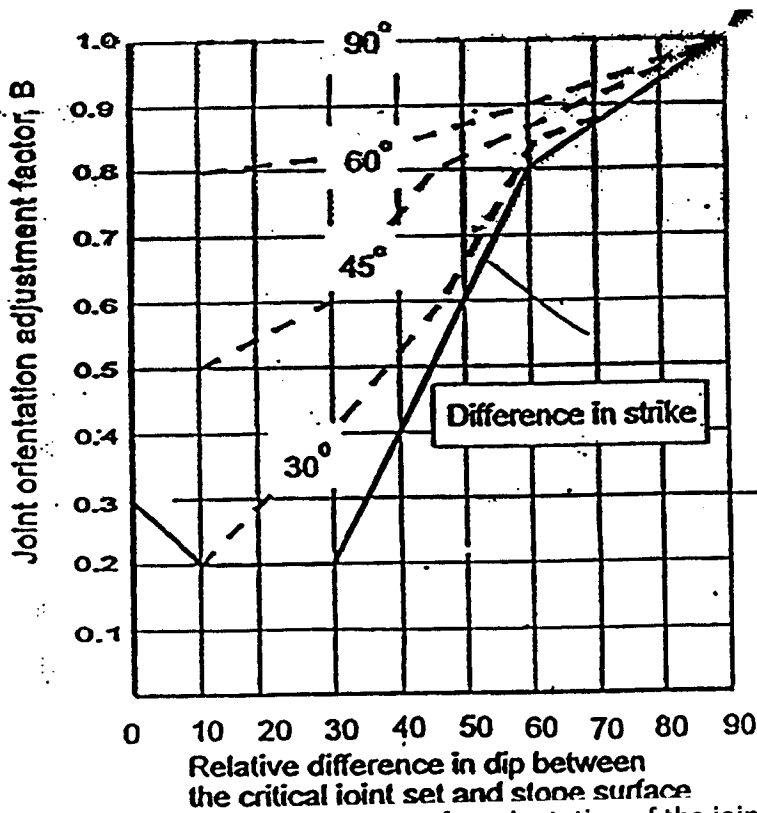

Figure 2: Adjustment factor, B, accounting for orientation of the joint with respect to slope surface (LEFT)

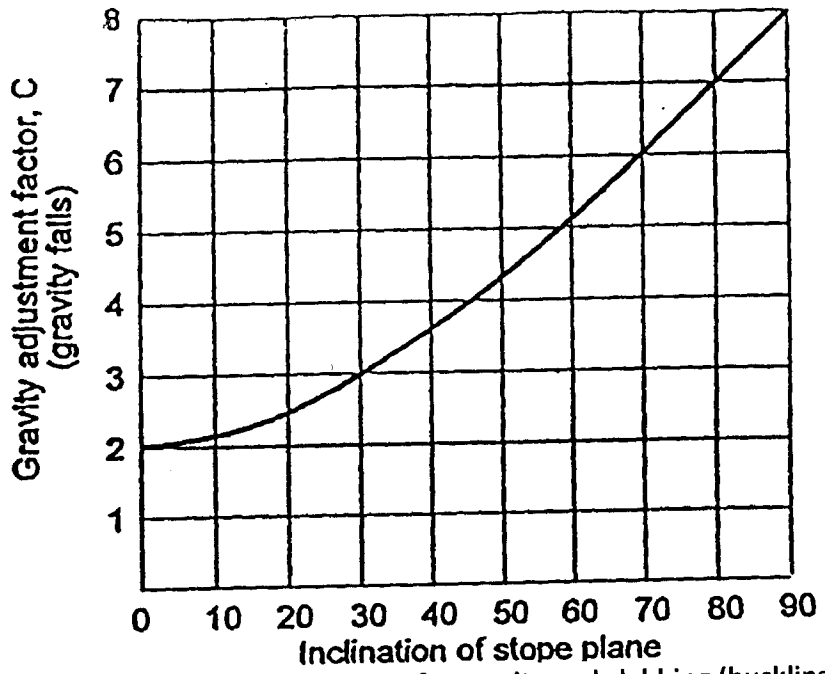

Figure 3: Gravity adjustment factor, C, for gravity and slabbing (buckling) fall modes of failure (after Potvin et al, 1988a) (RIGHT)

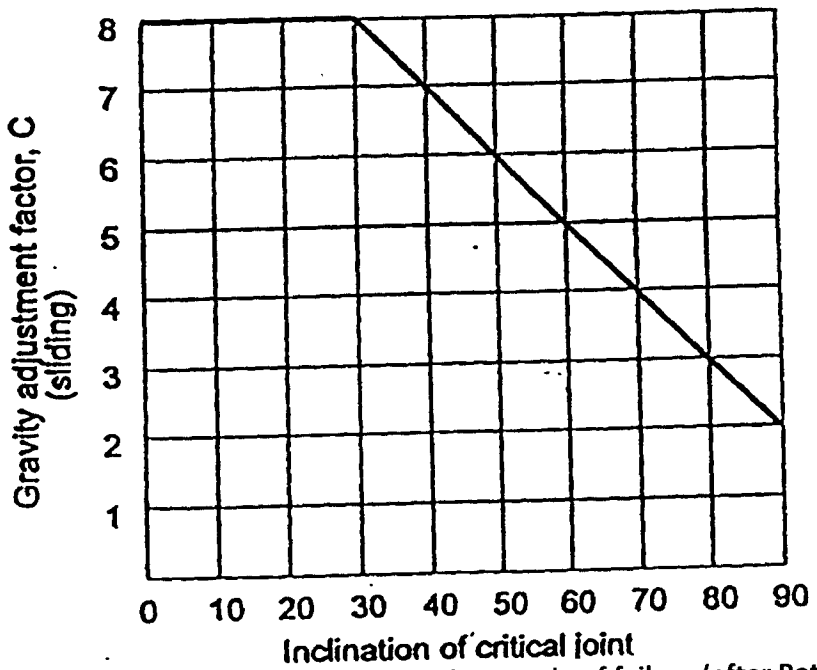

Figure 4: Gravity adjustment factor, C, for sliding mode of failure (after Potvin et al, 1988a)

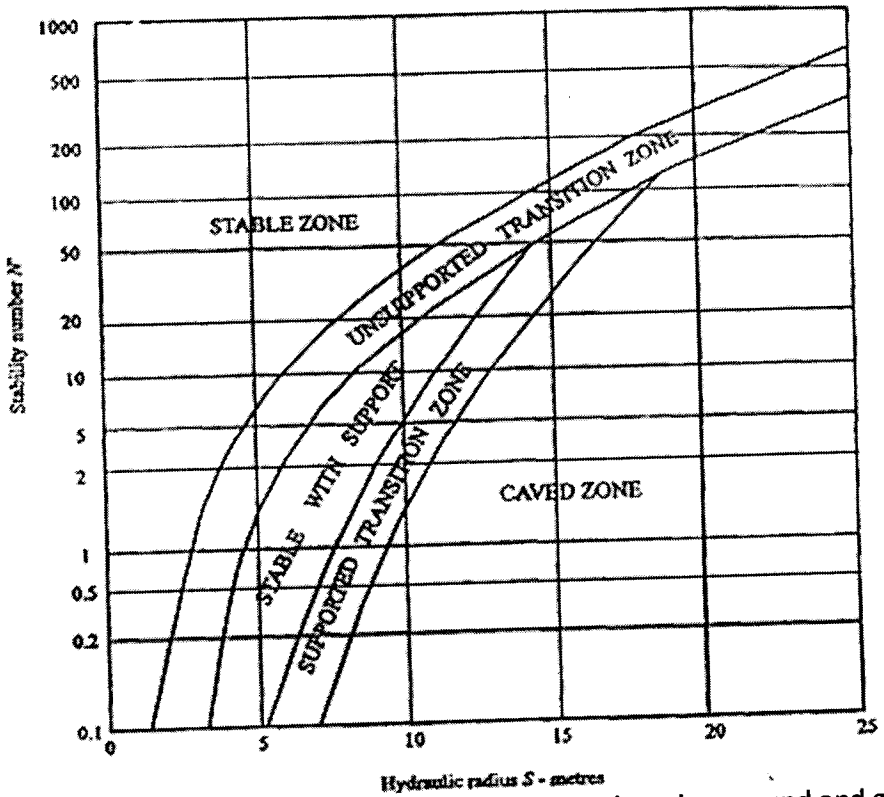

Figure 5: Stability chart showing zones of stable ground, caving ground and ground requiring support (after Potvin, 1988, modified by Nickson, 1992)

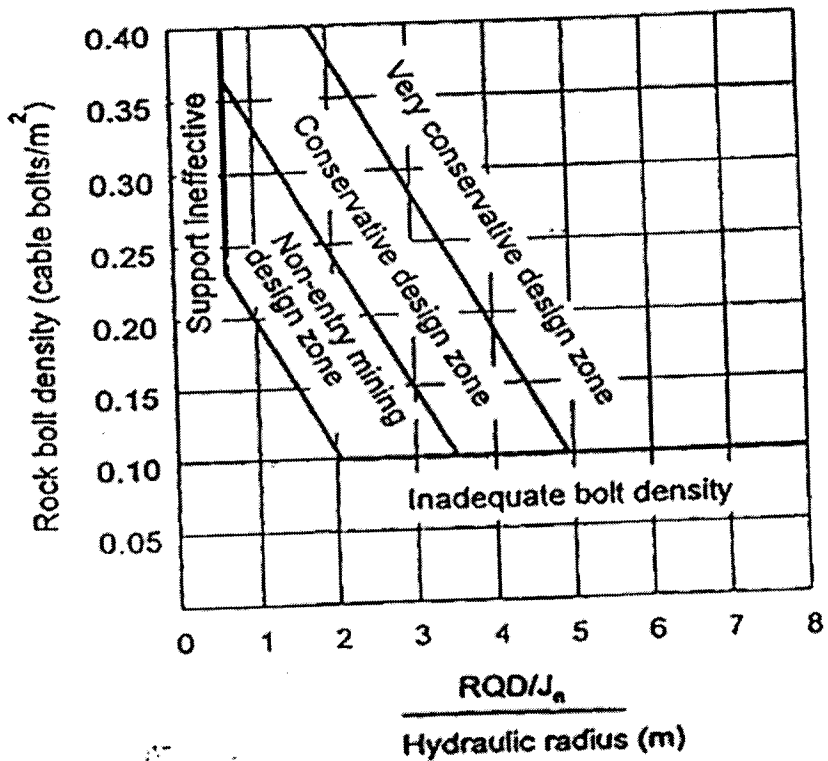

Figure 6: Cable bolt density chart

**THE UNIVERSITY OF ZAMBIA
SECOND SEMESTER UNIVERSITY EXAMINATIONS**

APRIL 2010 SEMESTER FINAL EXAMINATIONS

MI 335: SURFACE MINING

TIME : THREE [3] HOURS FULL MARKS : 100

INSTRUCTIONS: ANSWER QUESTIONS 1 AND 2, AND ANY OTHER THREE.

ALL QUESTIONS CARRY EQUAL MARKS

TIME: 3 HOURS

QUESTION 1

You will require a graph sheet to answer this question.

Assume a flat topography and a vertical rectangular ore body of constant grade as shown in Figure 1.

Further assumptions are that:

- The ore body is sufficiently long in strike to negate the end effects.
- Ore is worth US\$6.00 per tonne after all mining and processing costs have been paid.
- Waste costs US\$3.50 per tonne to remove.

You are required to:

- i. Calculate and tabulate the tonnages for the possible pit outlines. **[04 marks]**
- ii. Calculate and tabulate the values of each pit outline. **[04 marks]**
- iii. Draw a graphical plot of the pit value to pit tonnage. **[06 marks]**
- iv. Identify and comment on the optimal pit outline established above **[06 marks]**

**THE UNIVERSITY OF ZAMBIA
SECOND SEMESTER UNIVERSITY EXAMINATIONS**

APRIL 2010 SEMESTER FINAL EXAMINATIONS

MI 335: SURFACE MINING

TIME : THREE [3] HOURS FULL MARKS : 100

INSTRUCTIONS: ANSWER QUESTIONS 1 AND 2, AND ANY OTHER THREE.

ALL QUESTIONS CARRY EQUAL MARKS

TIME: 3 HOURS

QUESTION 1

You will require a graph sheet to answer this question.

Assume a flat topography and a vertical rectangular ore body of constant grade as shown in Figure 1.

Further assumptions are that:

- The ore body is sufficiently long in strike to negate the end effects.
- Ore is worth US\$6.00 per tonne after all mining and processing costs have been paid.
- Waste costs US\$3.50 per tonne to remove.

You are required to:

- i. Calculate and tabulate the tonnages for the possible pit outlines. **[04 marks]**
- ii. Calculate and tabulate the values of each pit outline. **[04 marks]**
- iii. Draw a graphical plot of the pit value to pit tonnage. **[06 marks]**
- iv. Identify and comment on the optimal pit outline established above **[06 marks]**

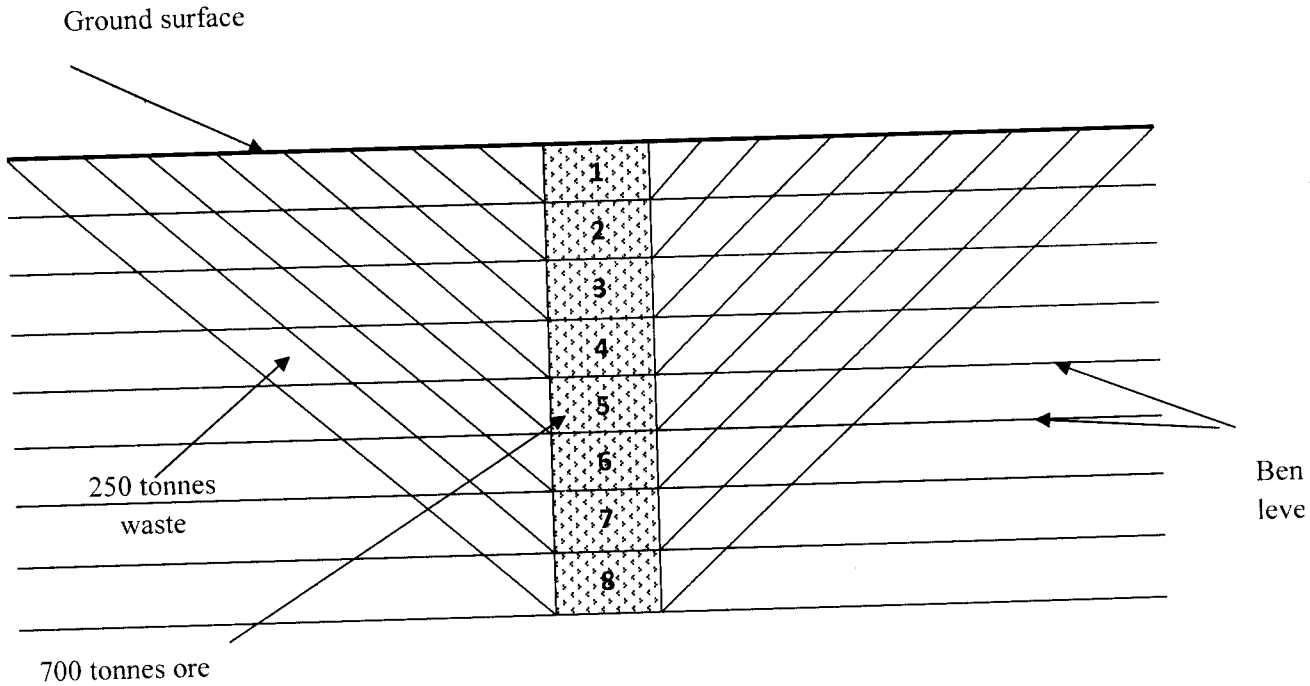

Figure 1

QUESTION 2

A. Given the following information:

Time period	24hrs (3 8-hr shifts)
Truck pan volume	93 m ³
Swell factor	0.7
Cycle time	40 minutes
Availability and utilization	90%
Density	2600 kg/m ³

Given that 1 BCM = 2.5 tonnes;

Calculate the number of trucks required to mine 500 BCM in the given period.

[10 marks]

B. Outline the various stages of building an ore body model, explaining the importance of each stage. [10 marks]

QUESTION 3

a) It is essential to determine the existing reserves well before a mining project begins. There are many methods that have been established for calculation of these reserves.

- i. Describe the ore reserve computation method by graticule analysis. [01 mark]
- ii. What conditions make this method suitable to use for computation of ore reserves. [02 marks]

iii. Give the formulae for overall volume and overall grade of graticule. [02 marks]

b) Figure 2 shows traces of an exploration drilling program. Drill hole information is given in table 1.

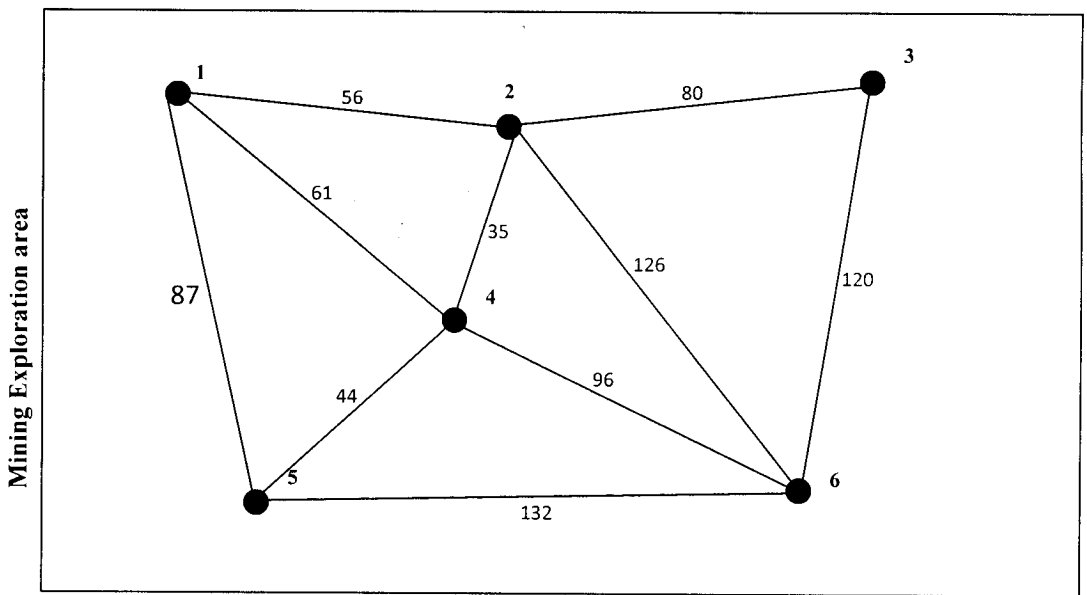

Figure2: Drillholes in Exploration program

Table 1: Drill hole data

Bore hole ID	Thickness of ore body intersection [m]	Grades [%]
1	120	2
2	111	3
3	73	2.5
4	66	1.6
5	96	4
6	100	3.5

ASSUMPTION

Assuming the thickness of the ore body is not a major factor in analysis and reserve calculation:

Given that the internal angle at drill hole 1 is 30° (triangle 145)

- i. Calculate all internal angles formed as a result of the drill hole collaring. **[03 marks]**
- ii. Using triangulation methods, calculate the average grades for the triangles formed. **[02 marks]**
- iii. Determine the angular weighted grades for each triangle. **[03 marks]**
- iv. Calculate the ore reserves by using thickness and angle weighting methods. **[03 marks]**
- v. What is the overall volume of the reserves and its tonnage given the ore density to be 2600 kg/m^3 . **[04 marks]**

QUESTION 4

- i. Clearly outline the various linkages of information models found Due Diligence studies. **[05 marks]**
- ii. Define a legally competent person, and give three examples in a surface mine project. **[02 marks]**

- ii. What are information time bombs? Give two examples of time bombs and ways to avoid them. **[03 marks]**
- iv. Describe the three pit entry systems in surface mining, giving one advantage and disadvantage in each system. **[04 marks]**
- v. Outline, with the aid of appropriate diagrams, the various stages of bench design, with bottom-up sequencing, highlighting the ramps, toe and bench crests. **[06 marks]**

QUESTION 5

For questions 5 and 6, please use the tables attached to this exam paper

- A. Write short notes on the application of the Positive Moving Cone techniques as a simulation algorithm for the determination of maximum valued pit, paying special attention to:
- i. How the algorithm works **[02 marks]**
 - ii. Its failure to design the true optimal pit. **[02 marks]**
 - iii. Its characteristics **[01 mark]**
- B. Given in Figure 3 is the sketch of a small 2-dimensional block model. The BEVs are written on blocks. Given that negative and positive values refer to waste and ore blocks respectively, and that the maximum allowable slope angle on the section is 1 block: 1 block on both the hanging wall and the footwall. Determine the maximum valued pit outline using the Positive Moving Cone technique showing all steps. **[15 marks]**

-1	-1	-1	-1	-1	-1	-1	-1	-1	-1
-2	-2	-2	-1	+2	+2	-1	-1	-2	-2
-3	-3	-3	-3	+3	+4	+2	-1	-2	-3
-4	-3	-2	-1	+7	+6	+5	-1	-3	-4
-5	-4	-3	+8	+7	+6	-1	-2	-3	-5

Figure 3

QUESTION 6

Using Figure 3 (as given in the preceding question), with all its attributes, and maintaining the maximum allowable slope angle at 1 block: 1 block on both hanging wall and footwall, determine the two alternative maximum valued pit outlines using the Dynamic Programming algorithm. Compare the values of the two pits and decide on a favourable pit outline.

[20 marks]

===== GOOD LUCK =====

THE UNIVERSITY OF ZAMBIA
SECOND SEMESTER UNIVERSITY EXAMINATIONS
APRIL 2010 SEMESTER EXAMINATION
MI 515 ROCK MECHANICS II

TIME : THREE [3] HOURS FULL MARKS : 100

INSTRUCTIONS: ANSWER QUESTION 1 AND ANY OTHER 5

QUESTION 1

1(a) What is the use of Geomechanics classification of rock masses ? Write the parameter used by Bieniawski's and Norwegian Geological Institute (NGI) ? Describe briefly, how these parameters can be measured ? (12 marks)

(b) Calculate the RMR if the Tunneling Quality Index 'Q' is equal to 400. Comments on the description and type of rock. based on the value obtained for RMR. (08 marks)

2(a) The superiority of using rock bolts as support system in underground working compared to conventional support (such as steel arches , guiders, posts and chocks) is well acknowledged . Why is it so? Explain , using diagrams. (10 marks)

(b) If the working load on each bolt to be provided is 10 t (100 kN), unit weight of in which the bolting has to be done is 25 kN/m³, the height of the weak zone required bolt is 4.0 m , calculate the spacing of the bolt to be installed and the approximate value of length of bolt. (06 marks)

3(a) What is tributary area method used for pillar design in room and pillar mining? Has it got advantage over the other methods used for the same purpose? Explain with the help of diagrams. (10 marks)

(b) Calculate the safe dimension of a coal to be mined using room and pillar mining given: mining depth=100m, the unit weight of over lying rock = 25 kN/m³, the total plan area where the pillars are being formed = 10, 000 m². Take safety factor of the pillars = 1.2 (06 marks)

4(a) Under which mining method the induced subsidence due to mining on the surface takes the shape of a TROUGH? Explain with the help of diagrams the reason for it.. (10 marks)

(b) Calculate the maximum possible subsidence that can occur if the extracted seam thickness is equal to 3.0 m . The values for S/m and s/S obtained from the curves are 0.6 and 1.2 respectively. (06 marks)

5(a) Explain the difference between ROCKBURSTS and OUTBURT that take place , the first one in hard rock mining and the other in mining coal. What are the causes of these occurrences and how they can be controlled? (10 marks)

(b)How rock bursts can be predicted ? Show the position of the equipment to be located in the mine for measuring this event. Show the combination of the equipment used for this purpose. (06 marks)

6 (a)What is meant by STAND-UP time in mining ? Explain using diagrams. (10 marks)

(b) Calculate the maximum unsupported span (in metres) which can remain stable if the value for Excavation Support Ratio (ESR) = 1.6 and equivalent dimension of roadway (De) is 4.8. (06 marks)

7(a) How can you measure the tightness of water or oil reservoir so that there is no seepage Describe the laboratory procedure for this purpose . 10 marks)

(b)Calculate (i) water content ,(ii) Porosity ,and (iii) Void ration of rock sample weighs = 1526 g an in the natural state = 1053 g. after drying. The unit weight of rock is = 2.70 g/ cm³ . (10 marks).

END OF EXAMINATION

THE UNIVERSITY OF ZAMBIA
SECOND SEMESTER UNIVERSITY EXAMINATIONS

APRIL 2010 SEMESTER FINAL EXAMINATIONS

MI 535: COAL MINING METHODS

TIME : THREE [3] HOURS FULL MARKS : 100

INSTRUCTIONS: ANSWER QUESTION ONE (1) AND ANY OTHER FIVE. ANSWERS SHOULD BE CLEAR AND BRIEF

QUESTION 1

There are certain requirements of the Coal Mine Statute which must be complied with in maintaining 'STANDARD OF VENTILATION, COAL DUST, and danger against INUNDATION. Write the requirements. Use diagrams where ever necessary. **[20 marks]**

QUESTION 2

- a) A 3.0 m thick coal deposit at a depth of 600m is highly prone to spontaneous combustion. **Suggest** a suitable mining method and **give reasons** for your choice. **[04 marks]**
- b) For the method chosen for mining the above coal:
- i. **Design a layout** of the coal face and give details of face equipment for cutting and transporting the coal from the face to the shaft bottom
 - ii. **Design the support system** giving their approximate number for a face length of 210 m
 - iii. **Determine the number of persons** you would employ giving their job description and the average OMS of the face. **[12 marks]**

QUESTION 3

- a) Although 90% of coal is mined universally by longwall mining method there are still certain situations where room and pillar mining is preferred. **Describe** these situations giving convincing reasons. **[04 marks]**
- b) **DESIGN** a room and pillar panel for extraction purpose giving details of (i) number of pillars you would recommend giving reasons for it, (ii) the shape and the dimension of the pillars. **Give the approximate production** during the formation of pillars (so called development), (iii) method of extraction of pillars

and (iv) the combination of machinery you would use for loading and transporting the coal. [3x4=12 marks]

QUESTION 4

- a) What is HORIZON mining? Explain the circumstances in which this method is used. Briefly describe the method with the help of diagrams [08 marks]
- b) What is known as RANK of coal? What are the factors on which the rank of coal depends? Can the rank of coal be changed? If so, how? [08 marks]

QUESTION 5

- a) How are coal seams (thicker than 6.0 m) mined? Describe a method (using diagrams) for mining a 12.0m thick seam at a depth of 600m below the surface. Describe the associated danger, if any, in mining such deposit. [08 marks]
- b) Presences of FAULTS and DYKES particularly in coal mines have serious detrimental effects. Describe these effects and remedial measures to be used for safe mining. [08 marks]

QUESTION 6

- a) Discuss the principles used in the design of coal pillars and whether existing methods are satisfactory? Which method would you like to use and why? [08 marks]
- b) A 3.0 m horizontal coal strata lying at a depth of 80m has rock cover having a unit weight of 25kN/m^3 . The layout for the working of this deposit has been planned on 6.0m room spans and 5.0m square pillars. Comment on the stability of such pillars and discuss ways to make them stable if their safety factor is less than the recommended value of 1.6. [08 marks]

QUESTION 7

- a) The run-of- mine (ROM) is not recommended to be used either for domestic or industrial purposes. Why is this so? [08 marks]
- b) Describe briefly with the help of a neat diagram a method generally used for cleaning coal before it is marketed. [08 marks]

END OF EXAMINATION

THE UNIVERSITY OF ZAMBIA
SECOND SEMESTER UNIVERSITY EXAMINATIONS

APRIL 2010 SEMESTER FINAL EXAMINATIONS

MI 565: MINERAL ECONOMIC II

TIME : THREE [3] HOURS FULL MARKS : 100

INSTRUCTIONS: ANSWER ALL QUESTIONS

QUESTION 1

- a) National income is the most important variable in macro-economic management of a nation.
- i. Why is the above statement true? **[2 Marks]**
 - ii. Differentiate between economic and non-economic activities. **[2 Marks]**
 - iii. Why would developing countries prefer measuring their national income in terms of GNI than GDP? **[2 Marks]**
 - iv. In the factor income method of national income accounting how are labour, capital and mixed income accounted for? **[4 Marks]**
 - v. Given that $C = 100 + 0.5Y$ and $I = 100$
Determine Equilibrium national income **[5 Marks]**
- b) The concept of the multiplier is very important in national income determination and is related to patterns of savings and consumption.
- i. Define the static multiplier **[2 Marks]**
 - ii. If a simple economy has $Y = K10,000$ and planned growth rate is 20%, $mpc = 0.8$
What is the required investment to reach this growth rate? **[5 Marks]**
 - iii. What are the major limitations of the multiplier? **[3 Marks]**

[TOTAL: 25 Marks]

QUESTION 2

Increasingly it is being stated that embracing globalization is all that is required to develop an economy;

- a) In this context differentiate between economic growth and sustainable development

[3 Marks]

- b) What should constitute a good mining policy? **[3 Marks]**
 - c) What would be your core components in your mining tax policy and why? **[3 Marks]**
 - d) Why are minerals so central to human affluence? **[3 Marks]**
 - e) Discuss the main determinants of modern economic growth emphasizing the active factors and how governments can improve these factors. **[5 Marks]**
 - f) What is the one variable that differentiates prospering societies and “failed societies” and how does leadership function in these societies? **[3 Marks]**
- [TOTAL: 20 Marks]**

QUESTION 3

- a) Your mining economy is facing cyclical periods of depressions and prosperity depending on movements in metal prices. You are the minister of Finance. What objectives would you set to allow the economy function with a reasonable degree of flexibility or stability? **[3 Marks]**
 - b) The economy is dependent on government policy on taxation and public expenditure programmes;
 - i. What is the relationship between public expenditure and GNP? **[3 Marks]**
 - ii. What is the relationship between taxation and GNP? **[3 Marks]**
 - c) In your counter cyclical fiscal policy what are;
 - i. The automatic budgetary changes? **[3 Marks]**
 - ii. The discretionary budgetary changes? **[3 Marks]**
 - d) Discuss the main complications you face in devising tax and expenditure policies to stabilize the economy. **[5 Marks]**
- [TOTAL: 20 Marks]**

QUESTION 4

You are a Central Bank governor in a mining economy in a poor society, where banking is not developed, as only a few people possess even money let alone access to banking services; there are only few financial services that are commercial, most others being informal.

- a) Answer the following questions:

- i. What would be the major instruments of your monetary policy? **[4 Marks]**
- ii. What would be their major limitations given your economy? **[4 Marks]**

Your economy which is controlled by the few commercial banks has only K100 billion in deposits. You impose a cash reserve ratio of 20%.

- i. What do you understand by the term credit multiplier? Calculate it for your economy? **[4 Marks]**
- ii. How much credit can your banks create? **[4 Marks]**
- iii. What is the total loan able portfolio in your economy? **[4 Marks]**

[TOTAL: 20 Marks]

QUESTION 5

mining projects depend for their success on positive and large revenues to recover costs incurred. This increasingly depends on mineral prices that are cyclical.

Answer the following questions:

- i. How do you go about arriving at prices to use in your project evaluation? **[1 Mark]**
- ii. What is the best time to invest in exploration projects in the price trend cycle? **[2 Marks]**
- iii. When is the best time to start production? **[3 Marks]**

Commodities have been traded before commodity exchanges using barter and forward contracts.

- i. What were the disadvantages of these arrangements **[3 Marks]**
- ii. Differentiate commodity exchange and stock exchange using securities traded on them and their major characteristics. **[3 Marks]**
- iii. Discuss the major functions of commodity exchanges. **[3 Marks]**

[TOTAL: 15 Marks]

THE UNIVERSITY OF ZAMBIA

SCHOOL OF MINES

UNIVERSITY EXAMINATIONS – APRIL/MAY 2010

MM 205 – INTRODUCTION TO MINERAL SCIENCES

TIME: THREE HOURS

ANSWER ANY FIVE QUESTIONS WITH AT LEAST ONE FROM EACH DISCIPLINE. USE SEPARATE ANSWER BOOKS FOR GEOLOGY, MINING AND METALLURGY QUESTIONS

SECTION I: INTRODUCTION TO GEOLOGY AND MINING

1. (a) Define the following terms: (5 marks)
- (i) Crystal
 - (ii) Space lattice
 - (iii) Face centered (F) lattice
 - (iv) Pinacoid
 - (v) Law of Constancy of Interfacial Angles
- (b) What are characteristic elements of symmetry? (2 marks)
- (c) Classify the 4 crystals in the Table below into crystal systems using the data provided and state why. (8 marks)

CRYSTAL ID	ELEMENTS OF SYMMETRY
1	3 tetrads, 2 triads, no hexads, 3 diads, 4 planes, centre
2	3 tetrads, 4 triads, no hexads, 6 diads, 9 planes, centre
3	1 tetrad, 3 triads, no hexads, 4 diads, 6 planes, centre
4	No tetrads, no triads, 1 hexad, 6 diads, 6 planes, centre

- (d) What is a mineral? Would you consider ice as a mineral? Why or why not? (5 marks)
2. (a) What is an atom? (2 marks)
- (b) What are isotopes? (2 marks)
- (c) Using sodium chloride as an example explain how a chemical reaction occurs. (3 marks)
- (d) Distinguish ionic bond from covalent bond. (6 marks)

(e) Define the following terms: (4 marks)

(i) Lustre

(ii) Hardness

(iii) Cleavage

(iv) Fracture

(f) Diamond and graphite are composed of the same substance and yet diamond is the hardest substance known to man and it is dense, while graphite is very soft and less dense. Why do you think this is so?

(3 marks)

3. (a) What is a rock? (2 marks)

(b) What is ore? (2 marks)

(c) Name the three groups of rocks and describe briefly how each one forms. (6 marks)

(d) Distinguish granite from basalt. (4 marks)

(e) Given that a hot solution contains a high concentration iron ions, copper ions, sulphur, and silica and this solution is passed through a crack in a limestone rock and as it does so it cools. The result is a vein. What sort of gangue minerals and ore minerals will be present in this vein? What caused the minerals to precipitate? (6 marks)

4. (a) Despite the fact that surface mining has several advantages over underground, still there are certain situations in which underground mining is preferred. Write these situations giving reasons for it. (10 marks)

(b) What are the different types of surface mining and underground mining? List the names. What are ideal conditions for adopting surface mining? (10 marks)

5. (a) Write the parameters to be considered in deciding the diameter of a mining shaft? What is the average diameter of a shaft in Zambia? Does the depth of the shaft affect the diameter of it?

(10 marks)

What are the application of these following and in which context these are used? Kibble; Pulleys; Rider; Folding Doors (upper and Lower); and Scaffold. (10 marks)

A shaft of 6.0 m has to be driven through a watery strata which runs at a small section . Write the details with the help of a neat diagram (i) the arrangement of drill holes ,(ii) number of drill holes (iii)amount of total explosive for each round of blast, (iv) Type of explosive and detonators you will use and (v)ventilation and Pumping arrangement (in case you have to deal with water). (10 marks)

Write the name of the equipment which are used for the following purposes: Velocity of air entering into the mine passage ; comfortable working temperature for workers working underground, Methane and other gases emissions such as carbon monoxide, nitrous fumes etc. (5 marks)

If the cross-section area of an air passage is doubled and the velocity of air is reduced to half, what will be the effect on the total quantity entering through that air passage? (5 marks)

SECTION II: INTRODUCTION TO METALLURGY AND MINERAL PROCESSING

7. a) What is the role of a Metallurgist in the Mining Industry? (4 marks)
- b) What do you understand by the terms Recovery and Grade? How are Minerals and Metals classified? (8 marks)
- c) How are Metallurgical processes broken down and give some example of a typical flow sheet. (4 marks)
- d) Give some important properties of Minerals. (4 marks)
-
8. a) What is meant by beneficiation of ores? (4 marks)
- b) Give a simplified flow sheet involving ore milling and flotation in a typical concentrator. (4 marks)
- c) What stages are normally involved in a typical flotation process? (4 marks)
- d) Name the various equivalent diameters used to describe particle sizes and shape. (5 marks)
- e) Give a good example of minerals floated in Zambia. (3 marks)
-
9. a) Give the characteristics of a Jaw crusher and Gyratory crusher. (6 marks)
- b) What do you understand by the following terms?
- i. Hydrophilic (2 marks)
 - ii. Hydrophobic (2 marks)
 - iii. Frother (3 marks)
 - iv. Modifiers (3marks)
 - v. Collectors (4 marks)
- } Give examples where you can.

THE UNIVERSITY OF ZAMBIA

SCHOOL OF MINES

UNIVERSITY EXAMINATIONS – APRIL/MAY 2010

MM 332 – CHEMICAL THERMODYNAMICS II

TIME: THREE HOURS

ANSWER: **QUESTION 1 AND ANY OTHER FOUR.** RELATIVE WEIGHT OF EACH QUESTION IS INDICATED IN BRACKETS.

1. (a) Briefly discuss and/or define the following thermodynamic concepts:

- (i) A solution, a mixture and a compound.
- (ii) Interaction coefficient
- (iii) Phase diagram
- (iv) Electrochemical cell
- (v) Chemical reaction kinetics

[10]

(b) The variation, with composition, of G^{xs} for liquid Au-Cu alloys at 1550 K is shown in the Table below;

X_{Cu}	0.1	0.2	0.3	0.4	0.5	0.6	0.7	0.8	0.9
G^{xs} , (J.mole ⁻¹)	-2170	-3850	-5050	-5770	-6010	-5770	-5050	-3850	-2170

Calculate:

[10]

- (i) \bar{G}_{Au}^{xs} and \bar{G}_{Cu}^{xs} at $X_{Cu} = 0.3$
- (ii) ΔG^M at $X_{Cu} = 0.3$

2. (a) Explain what is meant by the electrochemical series

[3]

(b) The reaction of a cadmium-calomel cell is represented as

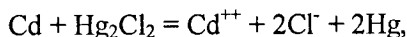

where all the components are present in their standard states. The reversible e.m.f. (in V) of the above cell varies with temperature (in K) according to the following relation:

$$E^{\circ} = 0.67 - 1.02 \times 10^{-4} (T - 298) - 2.4 \times 10^{-6} (T - 298)^2$$

Calculate values of ΔG° , ΔS° and ΔH° for the above reaction at 40 °C. [12]

- (c) (i) Show the individual reactions occurring at both half cells of the Daniel Cell. [2]
- (ii) Calculate the e.m.f. of a cell at 25 °C made of zinc and copper electrodes dipped into zinc sulphate solution of activity 0.1 and copper sulphate solution of activity 0.01 respectively. Assume any liquid junction potential to be negligible. [3]

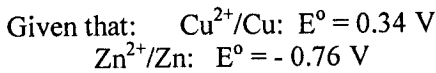

The Faraday's constant, $F = 96\,487 \text{ C/g-equivalent}$

3. (a) A heat of steel contains 0.002 wt % oxygen. Vanadium is to be added in the ladle at 1557 °C to make a product containing 1 wt % vanadium. To what extent must the oxygen content of the heat be lowered to prevent the loss of vanadium? [8]

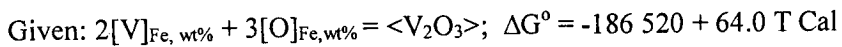

- (b) The following data were obtained for the kinetics of reduction of FeO in slag by carbon in molten pig iron at a certain temperature: [12]

Concentration of FeO in slag, wt %	20.00	11.50	9.35	7.10	4.40
Time, min	0	1.0	1.5	2.0	3.0

- (i) Using the Van't Hoff's differential method, calculate the order of the reaction with respect to FeO.
- (ii) Taking the order of reaction calculated in (i) above, calculate the rate constant and half-life for this process.

4. Two hypothetical metals, A and B, whose melting points are 700 °C and 500 °C respectively, are completely miscible in the liquid state and are partially soluble in the solid state, the maximum solubilities being 5 % B and 25 % A by weight. The solubilities are 2 % and 5 % respectively, at 0 °C. The A-rich phase is α and the B-rich phase is β .

The two metals form a compound A_2B which melts at 750°C and in which neither metal is soluble. The atomic weights of A and B are 30 and 50 respectively. Eutectics are formed at 22 % and 60 % by weight of B and at a temperature of 450°C and 320°C respectively. [15]

- (a) Draw a phase diagram on a graph paper and label the areas in the phase diagram with the relevant phases.
- (b) Calculate the amounts of B in the conjugate phases at 200°C for the equilibrium cooling of a 20 % B alloy.

5. (a) Using the appropriate form of Gibbs-Duhem equation, calculate the activity of bismuth in a Bi-Zn alloy containing 70 atom % Zn at 600°C from the following data obtained from vapour pressure measurements: [12]

X_{Zn}	0.1	0.2	0.3	0.4	0.5	0.6	0.7	0.8	0.9
γ_{Zn}	2.591	2.303	2.098	1.898	1.721	1.551	1.384	1.219	1.089

- (b) According to the limiting form of the Debye-Huckel theory, calculate the activity coefficients of each of the ions; Na^+ , SO_4^{2-} , OH^- , and H^+ in a solution that contains both 0.003 M Na_2SO_4 and 0.001 M NaOH . [8]

6. (a) The activity coefficient of Zn in liquid Cd-Zn alloys at 435°C can be represented by

$$\log \gamma_{\text{Zn}} = 0.38X_{\text{Cd}}^2 - 0.13X_{\text{Cd}}^3$$

- (i) Calculate the corresponding expression for the composition dependence of γ_{Cd} , and [8]
- (ii) hence calculate a_{Cd} in the $X_{\text{Cd}} = 0.5$ alloy at 435°C . [2]
- (b) An iron-chromium alloy is brought to equilibrium with H_2 - H_2O mixture in which $P_{\text{H}_2\text{O}}/P_{\text{H}_2} = 0.00353$ in a pure alumina crucible at 1700°C .

The equilibrium is represented by $(\text{H}_2) + [\text{O}]_{\text{Fe, wt \%}} = (\text{H}_2\text{O})$

The alloy at equilibrium contains Cr: 1.90 %, Al: 0.031 % and O: 0.0032 % by weight. The values of various interaction parameters are;

$$e_{\text{O}}^{\text{O}} = 0; \quad e_{\text{O}}^{\text{Cr}} = -0.058; \quad e_{\text{O}}^{\text{Al}} = -3.15$$

Calculate the free energy change of the above reaction at 1700°C . [10]

END OF EXAMINATION IN MM 332

THE UNIVERSITY OF ZAMBIA

SCHOOL OF MINES

UNIVERSITY EXAMINATIONS – APRIL/MAY 2010

MM 352 – HEAT AND MASS TRANSFER

TIME: THREE HOURS

ANSWER ANY FIVE QUESTIONS

1. (a) Given that A and B are ideal gases in a mixture, derive the following equations:

(i) $N_{AZ} = - \frac{D}{RT} \frac{dP_A}{dz}$ [3]

(ii) $N_{AZ} = - Dc \frac{dX_A}{dz}$ [3]

- (b) Define the following terms:

(i) Equimolecular counter diffusion [2]

(ii) Convective mass transfer [2]

(iii) The molecular diffusivity [2]

- (c) A gas is being transferred across a stagnant air film at a total pressure of 100 kN/m^2 . The partial pressure of the gas is 40 kN/m^2 at one boundary of the film and 10 kN/m^2 at the other. If the partial pressures remain constant, calculate the total pressure in kN/m^2 to double the transfer rate of the gas. Given that the gas constant = 8.314 J/mol.K .

[10]

2. (a) At a point in an atmospheric pressure distillation column containing a benzene-toluene mixture, the temperature is $99 \text{ }^\circ\text{C}$ and the liquid and vapour phases contain 30 mol % and 40 mol % benzene respectively. The vapour pressure of toluene is 72 kN/m^2 at the temperature and its diffusivity may be taken as $5.4 \times 10^{-6} \text{ m}^2/\text{s}$. If the resistance mass transfer lies in a film 0.5 mm thick.

Calculate the rate of interchange of benzene and toluene between the liquid and the vapour phases assuming:

- (i) Equimolecular counter diffusion [8]
 - (ii) One component is not diffusing [8]
 - (iii) Comment on the difference in the rate of interchange [2]
- (b) State the assumptions made in solving problem 2 (a) [2]
3. (a) Ammonia gas is diffusing through a stagnant layer of air 1 mm thick at a temperature of 20 °C and at atmospheric pressure. At one boundary, the gas contains 50 vol. % of ammonia and at the other, the concentration of ammonia may be considered negligible. If the diffusivity of ammonia under these conditions is $1.8 \times 10^{-5} \text{ m}^2/\text{s}$, calculate the rate of diffusion of ammonia through the layer. [10]
- (b) On what factors is the rate of the separation process dependant? [2]
- (c) Considering a control volume in the fluid, show that $N_{AZ} = h_D (C_{A1} - C_{A2})$, stating all the assumptions made and define h_D . [8]
4. (a) Current is passed through a cylindrical laboratory heater, which has a 3 cm diameter, generating heat at the rate of 20 MW/m^3 . The heater is exposed to a convection environment at 25°C where the convection heat transfer coefficient is $0.5 \text{ kW/m}^2\text{°C}$. Sketch the heater, indicating all dimensions and boundary conditions, and determine its surface temperature. [10]

- (b) Calculate the gas film coefficient K_G for the absorption of sulphur dioxide from a dilute mixture with air in a wetted wall column using the experimental data below

Inside diameter of column,	d	=	25mm
Gas velocity,	v	=	2.2m/s
Gas temperature,	T	=	293K
Gas viscosity,	μ	=	$1.78 \times 10^{-5} \text{ Ns/m}^2$
Gas density,	ρ	=	1.22 kg/m^3
Diffusivity,	D	=	$12.2 \times 10^{-6} \text{ m}^2/\text{s}$
Gas constant,	R	=	8.314 kJ/kmol .K

Use Gilliland and Sherwood's correlation to calculate the effective film thickness x (mm). [10]

5. Laminated Sheets are constructed from single Sheets of a plastic using a suitable adhesive. When a number of sheets have been assembled they are clamped. The steel plates are maintained at a temperature of 343 K to dissipate heat evolved during hardening process. At maximum, the heat is equivalent to a steady uniform heat of 100 W/m^3 . Sketch a diagram and label $x = L$, $x = 0$, $x = -L$.

- (a) Given that the thermal conductivity of the stack is 0.2 W/mK and the heat transfer is assumed to be one dimensional, Convert the following expression to its rightful form and use it for the following question (b).

$$\frac{d^2T}{dx^2} + \frac{d^2T}{dy^2} + \frac{d^2T}{dz^2} + \frac{H}{K} = 0 \quad [8]$$

- (b) How many laminated sheets which are 3 mm thick, can be processed at any one time if the maximum temperature in the stack does not exceed 353 K? [12]

6. A small disc, thickness 't' of a certain material under test is sandwiched between two cylinders of the same diameter and made of the same material with known conductivity k. the composite cylinder fits into an insulator housing equipped with a heat source and heat sink each on either sides. During a test to determine its thermal conductivity, the temperatures T_a , T_b , T_c , T_1 and T_2 are measured by thermocouples.

(a) Sketch the temperature distribution along the cylinder. Derive an expression for T_1 . [8]

(b) Derive an expression for the unknown conductivity k, temperatures are at their locations a, b, c, and k_{cyl} as known. [12]

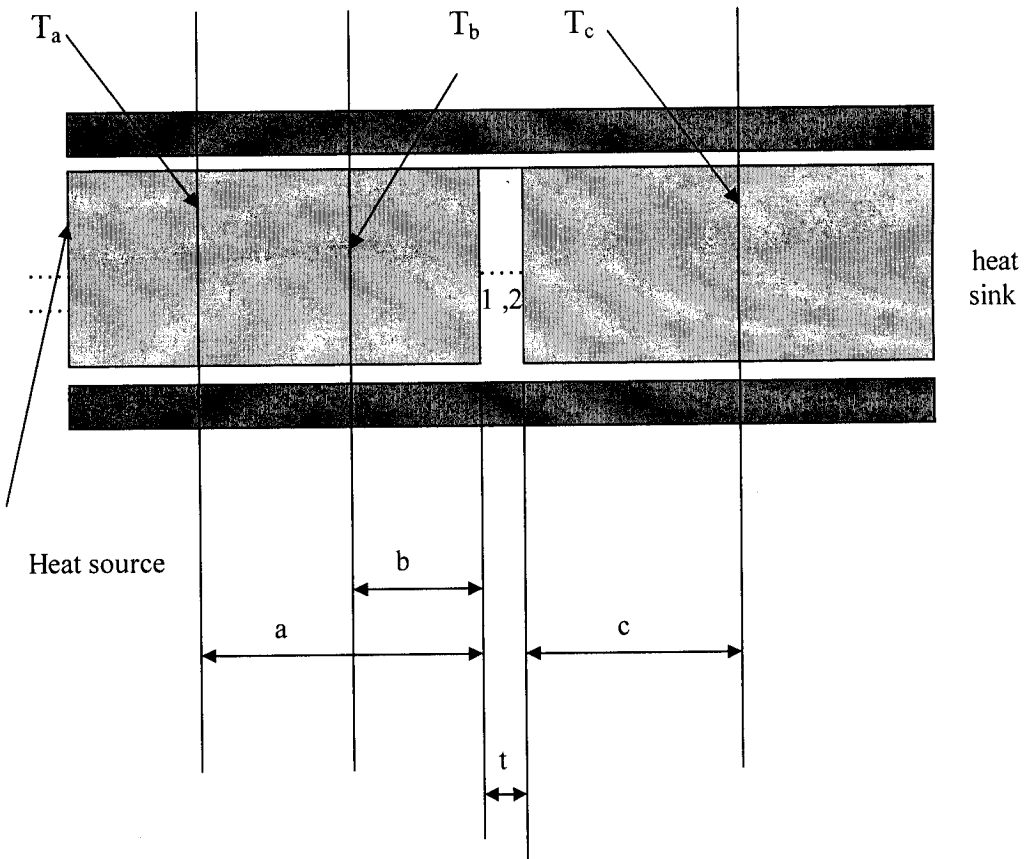

END OF EXAMINATION IN MM 352

THE UNIVERSITY OF ZAMBIASCHOOL OF MINESUNIVERSITY EXAMINATIONS – APRIL/MAY 2010MM 412 – MINERAL PROCESSING II**TIME:** THREE HOURS**ANSWER QUESTION 1 AND ANY OTHER FOUR. RELATIVE WEIGHT OF EACH QUESTION IS INDICATED IN BRACKETS.****1.** State briefly but clearly what you understand by the following terms, used in minerals engineering:

- (i) Shear-thickening
- (ii) Particulate fluidisation
- (iii) Consolidation trickling
- (iv) The settling factor in hindered settling
- (v) Space rate
- (vi) Incipient fluidization
- (vii) The critical pH of a collector/mineral combination
- (xiii) Reslurry washing
- (ix) The scale of turbulence
- (x) Cationic collectors [20]

- 2.** (a) (i) Derive the expression for the settling velocity of a particle in turbulent flow.
- (ii) What is understood by the “free settling ratio” and “hindered settling ratio” of two mineral particles?
- (iii) Explain briefly, but clearly, why hindered settling ratios are larger than the free settling ratios for the same mineral particles. [10]
- (b) Derive Leva’s equation for the minimum fluidisation velocity in a fluid bed reactor.

With this equation, show that, under laminar flow conditions, a bed with a wide range of particle sizes can be fluidised without elutriation.

At high Reynolds numbers, elutriation of the finer particles is likely to occur. Why is this not considered to be a disadvantage in most industrial applications? [10]

3. (a) Give a brief outline of the Coe and Clevenger method of calculating the required thickener area for a particular feed slurry.

Why is this method not suitable for flocculated pulps? [5]

- (b) A slurry fed at a rate of $1.8 \text{ m}^3/\text{min}$, containing $167 \text{ kg}_{\text{solid}}/\text{m}^3$ is to be thickened to $1200 \text{ kg}_{\text{solid}}/\text{m}^3$. From the results of a single batch test, the Kynch theory has been used to derive the following data relating the solids concentration c (kg/m^3) to the sedimentation velocity u_c (mm/min):

Concentration	c	kg/m^3	167	200	250	286	333	400	455	500
Settling velocity	u_c	microns/s	138.9	97.2	72.2	56	44.4	33.3	27.8	24.2

You may assume a solids density of $3000 \text{ kg}/\text{m}^3$ and a liquid density of $1000 \text{ kg}/\text{m}^3$.

Use the technique derived from the Coe-Clevenger equation incorporating the mass ratios of solid and liquid in the various streams, i.e. D and D_U to determine the required area of the thickener and the corresponding diameter. [8]

- (c) Describe a procedure for establishing the mean specific cake resistance, the cake resistance coefficient and the cake compressibility coefficient by a series of laboratory batch filtration tests.

Draw rough graphs to illustrate the procedure. [7]

4. (a) What do you understand by the "concentration criterion" in gravity separation? State in a few words what use is made of this criterion in the separation of minerals by gravity methods. [4]
- (b) Draw a rough diagram of the cross-section through a Harz jig, used in the concentration of cassiterite, whereby the concentrate is collected "on the screen". Describe the operation of this jig briefly. [4]
- (c) Draw a rough diagram of the cross-section through a Denver jig, used in the concentration of cassiterite, whereby the concentrate is collected "through the screen". Describe the operation of this jig briefly. [4]
- (d) Draw a rough diagram of the cross-section through a Batac jig, used in the cleaning of coal. Describe the operation of this jig briefly. [4]
- (e) Briefly summarise the main differences between these jigs and between their operations. [4]

- (a) Draw a schematic diagram of a flotation column in operation, labelling the most important parts of it. Indicate the process streams with arrows in your diagram. [4]

What do you understand by the terms superficial gas rate (velocity) and gas holdup?

- (b) Describe briefly how flotation process occurs in the column. What would you consider to be the most suitable field(s) of application for flotation columns? [4]

- (c) What do you consider to be the most characteristic feature of a flotation column, as compared to a traditional bank of mechanical flotation cells? [4]

- (d) What are the main operating parameters in column flotation? Discuss briefly. [4]

- (e) Can you name some of the types of flotation cells falling in the following categories: [4]

- (i) Mechanical
- (ii) Pneumatic

- (a) (i) What is the essential difference between anionic flotation collectors and cationic flotation collectors? [2]

- (ii) Name two groups of common anionic flotation collectors and one group of cationic collectors and give for each group its general chemical structure and its usual field of application in flotation. [3]

- (b) It is given that a complex sulphide ore contains galena, sphalerite, bornite, chalcopyrite and pyrite and that its treatment by froth flotation yields three different concentrates: a lead concentrate, a zinc concentrate and a copper concentrate. The main reagents used in this flotation process are:

- Copper sulphate
- Lime
- Sodium dichromate
- Sodium iso-propyl xanthate
- Methyl iso-butyl carbinol
- Sodium cyanide

- (i) State briefly what the function would be of each of the above reagents this flotation process. [3]

- (ii) Draw a simplified flowsheet for this flotation process, showing its main stages, and indicate in the flowsheet where you would add each of the above reagents (some reagents may be added at more than one addition point).

Indicate the principal mineral composition of each of the concentrates, obtained with this flowsheet. [5]

- (c) Given is that a lead-zinc ore is subjected to differential flotation to give a lead concentrate, a zinc concentrate and a zinc tailing, as follows:

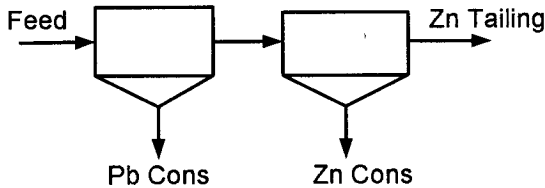

Complete the metallurgical balance below for one shift, during which 1000 tonnes of this ore were treated (Show your working).

[7]

Product/ Stream	Weight (t)	Assay (%)		Weight (t)		Recovery (%)	
		Pb	Zn	Pb	Zn	Pb	Zn
Feed	1000	10.0	12.8	-	-	-	-
Pb Cons	-	50.0	-	-	-	-	-
Zn Cons	246	1.6	26.0	-	-	-	-
Zn Tails	-	1.0	5.6	-	-	-	-

- (a) Why is the disposal of tailings very important in a metallurgical plant? [3]
- (b) Briefly describe the construction of tailings dumps by the spraying methods and cycloning with rough sketches. [4]
- (c) Mention some of the most positive uses of tailings, citing specific uses. [3]
- (d) Distinguish the differences between upstream and downstream methods of constructing tailings dams. Illustrate these differences by making schematic diagrams. [4]
- (e) What would you consider to be the most important precaution to be taken when starting a tailings dump with the downstream method? Explain your answer briefly. [3]
- (f) Briefly state the main measures that should be taken to maintain tailings dumps in a safe and environmentally acceptable condition. [3]

THE UNIVERSITY OF ZAMBIA
SCHOOL OF MINES

2009/10 ACADEMIC YEAR SECOND SEMESTER
FINAL EXAMINATIONS

MM422: PHYSICAL METALLURGY II

TIME: THREE HOURS

INSTRUCTIONS: ANSWER ALL THE QUESTIONS IN SECTION A AND TWO QUESTIONS
IN SECTION B

SECTION A

1. Discuss the validity of the following statements, in each case explaining your reasoning:
 - (a) Steels with fine grain sizes tend to have lower ductile-brittle transition temperatures
 - (b) Strain ageing is not always beneficial to a material.
 - (c) Martensitic transformations can occur in non-ferrous materials as well.
 - (d) Diffraction only occurs at specific angles of orientation of a material with respect to an incident x-ray beam.

2. (a) On which principle are almost all strengthening mechanisms based?
 - (b) Which of the strengthening mechanisms can occur in:
 - (i) Pure elements?
 - (ii) Single-phase solids?
 - (iii) Multiple-phase solids?
 - (c) Using an appropriate sketch, describe the mechanism of polycrystalline strengthening, including an explanation of why this mechanism works so well for fine-grained materials.

3. (a) What is creep?
 - (b) With the aid of an appropriate sketch, describe the three stages of a typical creep curve.
 - (c) Why is creep such a problem in fine-grained materials?
 - (d) From your experience in the creep laboratory exercise, outline how you would determine the creep rate and stress in a soft metallic material.

SECTION B

4. (a) Briefly describe the x-ray diffractometer method.
 - (b) With the aid of appropriate sketches, describe how x-ray diffraction can be used to denote phase changes (e.g. solvus lines) on a phase diagram.
 - (c) Cuprite (Cu_2O) is cubic and the following Bragg angles (θ) were observed on its diffraction pattern taken with $\text{CuK}\alpha$ radiation ($\lambda = 1.5418 \text{ \AA}$):

14.79, 18.22, 21.17, 26.25, 30.70, 36.80, 38.70 and 46.24°

- (i) Index the peaks
- (ii) Evaluate the unit cell dimension 'a'.
- (iii) Is the structure of cuprite simple cubic, bcc or fcc? Explain your reasoning.

5. (a) Why was the Griffith criterion proposed?
- (b) What is the main limitation of the Griffith criterion in its application to metallic materials and how has this been rectified?
- (c) During the water quenching of a steel component, 30 mm in section, heat transfer calculations indicate that the stress generated is 130 MPa. The K_{IC} determined in laboratory tests was $30 \text{ MPam}^{1/2}$ and the yield stress was 620 MPa. The maximum size of surface defect specified in production is 0.50 mm.
- Calculate the tolerable defect size if the flaw shape parameter Q is 1.1
 - What would be the situation if the generated stress approached the yield strength of the material and Q is 0.88?
 - Comment on the risk of failure introduced by the presence of each flaw size determined in parts (i) and (ii).

$$\left(\frac{a}{Q}\right)_c = \frac{K_{IC}^2}{1.21\pi\sigma^2}$$

6. (a) With the aid of appropriate sketches, describe the mechanisms by which microconstituents form during slow-cooling of a hypereutectoid steel.
- (b) After being slowly cooled from the austenite region, a hypoeutectoid steel exhibits a microstructure consisting of 40% pearlite and 60% ferrite.
- Estimate the carbon content in the steel.
 - Describe the equilibrium microstructure that would be obtained if the steel were heated to 730°C and held there for a long period of time.
 - What would be the equilibrium structure of this steel if it were heated to 850°C ?
- (c) For the decomposition of austenite to pearlite, it can be shown that the fraction of austenite transformed ($f(t)$) is related to the nucleation rate (N) and the growth rate (G) by the following expression:

$$f(t) = 1 - \exp\left(-\frac{\pi N G^3 t^4}{3}\right)$$

If $N=1000 \text{ cm}^{-3}\text{s}^{-1}$ and $G=3 \times 10^{-5} \text{ cm s}^{-1}$, what is the time required to obtain 50% transformation?

END OF EXAMINATION IN MM422

Question	1	2	3	4	5	6
Points	12	14	16	20	20	20

APPENDIX 10
 QUADRATIC FORMS OF MILLER INDICES

$h^2 + k^2 + l^2$	Cubic				Hexagonal	
	hkl				$h^2 + hk + k^2$	hk
	Simple	Face-centered	Body-centered	Diamond		
1	100				1	0
2	110	. . .	110		2	
3	111	111	. . .	111	3	11
4	200	200	200		4	20
5	210				5	
6	211	. . .	211		6	
7					7	21
8	220	220	220	220	8	
9	300, 221				9	30
10	310	. . .	310		10	
11	311	311	. . .	311	11	
12	222	222	222		12	22
13	320				13	31
14	321	. . .	321		14	
15					15	
16	400	400	400	400	16	40
17	410, 322				17	
18	411, 330	. . .	411, 330		18	
19	331	331	. . .	331	19	32
20	420	420	420		20	
21	421				21	41
22	332	. . .	332		22	
23					23	
24	422	422	422	422	24	
25	500, 430				25	50
26	510, 431	. . .	510, 431		26	
27	511, 333	511, 333	. . .	511, 333	27	33
28					28	42
29	520, 432				29	
30	521	. . .	521		30	
31					31	51
32	440	440	440	440	32	
33	522, 441				33	
34	530, 433	. . .	530, 433		34	
35	531	531	. . .	531	35	
36	600, 442	600, 442	600, 442		36	60
37	610				37	43
38	611, 532	. . .	611, 532		38	
39					39	52
40	620	620	620	620	40	
41	621, 540, 443				41	
42	541	. . .	541		42	
43	533	533	. . .	533	43	61
44	622	622	622		44	
45	630, 542				45	
46	631	. . .	631		46	
47					47	
48	444	444	444	444	48	44
49	700, 632				49	70, 53

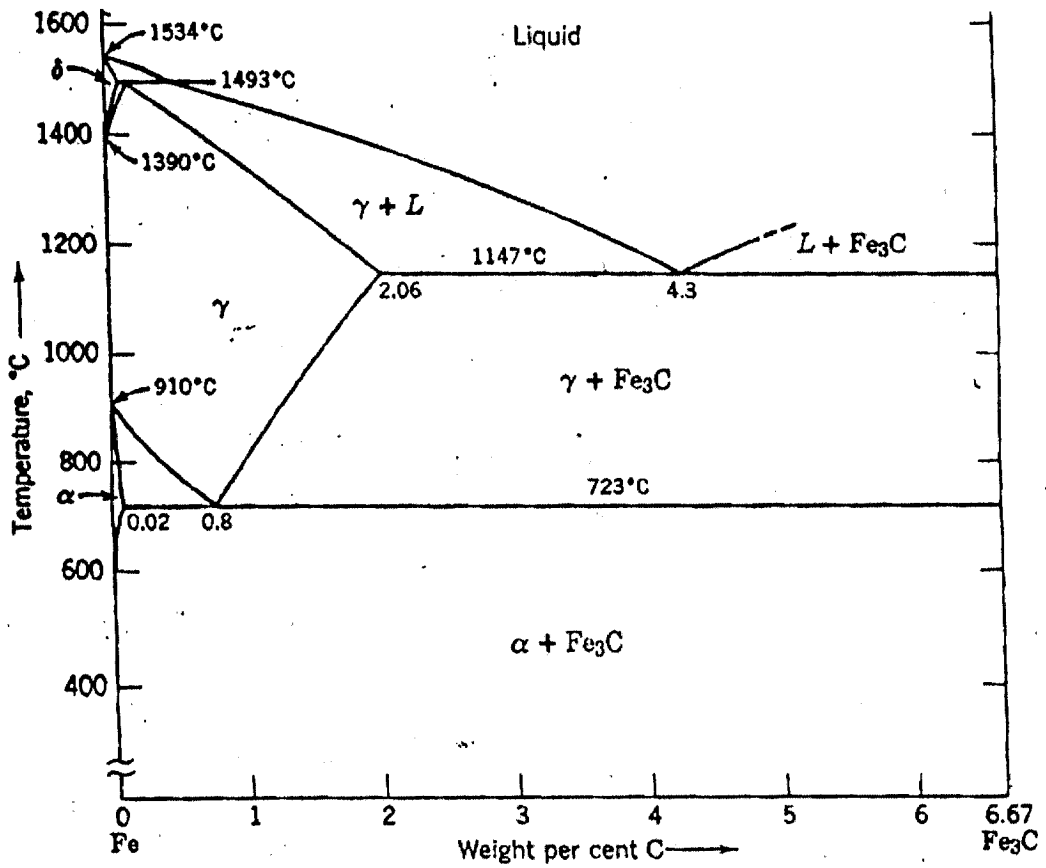

Phase diagram for the system Fe-Fe₃C.

THE UNIVERSITY OF ZAMBIA

SCHOOL OF MINES

UNIVERSITY EXAMINATIONS – APRIL/MAY 2010

MM 442 – HYDROMETALLURGY

TIME: THREE HOURS

ANSWER ALL FIVE QUESTIONS. THE CREDIT FOR A FULL ANSWER IS SHOWN IN BRACKETS BESIDE EACH QUESTION

1. (a) Use the data given below to derive an equation which expresses the redox neutrality of aqueous media as a function of pH at 25 °C. [8]

DATA

Universal gas constant, $R = 8.314 \text{ J/K/mol}$

Faraday constant, $F = 96500 \text{ C/mol}$



- (b) With the aid of the equation derived above, draw a clearly labelled Eh-pH diagram at 25°C showing the four broad categories of leachants. [5]
- (c) In dilute inorganic acid, the uranium ore mineral uraninite may undergo reductive chemical, or oxidative dissolution. Explain why commercial leaching of uraninite ore uses oxidative conditions and write down the leaching reaction if ferric ions are used as oxidant. [7]
2. In a continuous agitation leaching and counter current decantation (CCD) washing operation, 3.75 tonnes of solute-free leachant is used for every 1.5 tonnes of concentrate fed to the leaching vessel. The concentrate contains 10 % of a valuable metal M, 10 % moisture, and the remainder is insoluble gangue. Metal M completely dissolves in the leaching vessel before the slurry

enters the first thickener of a CCD washing operation with three thickeners. Per 1.5 tonnes of concentrate fed, 5 tonnes and 2 tonnes of wash water is added to the last and middle thickeners, respectively.

- (a) Draw a clearly labelled diagram that would best represent the operations as described above, if the pregnant solution exits the first thickener and a disposable sludge leaves the last thickener. [2]
- (b) If the underflow of each thickener contains 40 weight percent solids, calculate the amount of pregnant solution produced per 1.5 tonnes concentrate fed. [4]
- (c) With the further information that the repulping efficiencies of the first, middle, and last thickeners are 85 %, 90 %, and 95 % respectively, calculate the washing efficiency attained in the recovery of metal M. [10]
- (d) What measures would you advocate being used in an effort to increase the washing efficiency of metal M? State demerits of any proposals you make. [4]

3. (a) Outline the methods available for the precipitation of iron from metallurgical process solutions. [6]
- (b) Use the following equations to derive Elsner's equation for the leaching of gold ores. Why is a pH of 9-10 used? [5]

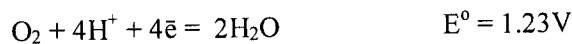

- (c) Explain the mechanisms responsible for the adsorption of gold from cyanide leach solutions by activated carbon. What is the role of calcium cations? [7]
- (d) Can ion exchange be used for the purification and concentration of gold-bearing cyanide solution? Explain. [2]

4. (a) Explain with the aid of an appropriate example the extraction and stripping mechanism for an anion exchange extractant. [6]
- (b) 300 cm³ of a loaded organic is contacted with 50 cm³ of a strip solution. If 90 % of the solute is stripped, what is the value of the stripping coefficient? For a particular loaded organic and strip solution, what factors affect the value of the stripping coefficient? [7]
- (c) As used in the extraction step of solvent extraction, what is a McCabeThiele diagram? Explain how it is generated and used. [7]
5. (a) How much energy (in kWh) is needed per kilogram of copper cathodes produced if copper anodes are refined at a cell voltage of 0.3 V and a current efficiency of 95 %?
(Relative atomic weight Cu = 63.5; F = 96500 C/mol). [8]
- (b) A zinc electrowinning cell contains 39 anodes and 38 cathode arranged alternately and connected electrically in parallel. Calculate the time (in hours) required by such a cell to plate out 500 kg of zinc if the current density used is 200 A/m² and the submerged area of each cathode is 1m². Assume a current efficiency of 90 % (Relative atomic weight of Zn = 65.4; F = 96500 C/mol) [12]

END OF EXAMINATION IN MM 442

THE UNIVERSITY OF ZAMBIA

SCHOOL OF MINES

UNIVERSITY EXAMINATIONS – APRIL/MAY 2010

MM 452 – PROCESS CONTROL AND INSTRUMENTATION

TIME: THREE HOURS

ANSWER ANY FIVE QUESTIONS.

WHERE APPLICABLE, ALL CALCULATIONS ARE TO BE PERFORMED CORRECT TO THREE DECIMAL PLACES.

ADDITIONAL INFORMATION IS PROVIDED WITH THE QUESTION PAPER.

1. (a) What is the job we have to do in process control?

(3 marks)

(b) A minibus driver uses the difference between the actual heading of the minibus and the lane marking on the road to generate a controlled adjustment of the direction of travel. Draw a block diagram to illustrate this feedback system. Indicate the variables into and out of each block.

(5 marks)

- (c) The dynamics of a tank without any control are given as follows:

$$\rho A \frac{dh}{dt} = x(t) = m_i - m_o = \Delta m(t)$$

where h = height of liquid in the tank

m_i = mass flow rate into the tank

m_o = mass flow rate out of the tank

Assume that $h(0) = h_0$.

Derive the expression for $h(t)$ for a step input magnitude $\Delta m = K U(t - t_d)$. Give the output in dimensionless form and determine its value at $t/t_d = 4$.

(7 marks)

- (d) A dynamic equation is of the following form:

$$t \frac{dy}{dt} + y = 3t^3$$

Given that $y = -1$ when $t = 1$, solve for the output $y(t)$.

(5 marks)

2. (a) An isothermal, first-order, liquid-phase, irreversible reaction is conducted in a constant-volume batch reactor thus

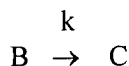

The initial concentration of reactant B at the beginning of the batch is C_{B0} . The specific rate k decreases with time because of catalyst degradation as $k = k_0 e^{-\alpha t}$. Solve for $C_B(t)$. Show that

in the limit as $\alpha \rightarrow 0$, $C_B(t) = C_{B0}e^{-k_0t}$ and that in the limit as $\alpha \rightarrow \infty$, $C_B(t) = C_{B0}$. What is the physical significance of each of these limits? Remember $e^{\alpha t} = 1 + \alpha t + \frac{\alpha^2}{2} + \dots$ (6 marks)

(b) A first-order system is given by

$$\frac{dy}{dt} = -\frac{y}{4} - \frac{x}{2} \quad y(0) = 1$$

The input disturbance x is initially zero. At $t = 2$, however, x undergoes a rectangular pulse of magnitude 1.5 and duration 1.5.

- (i) Determine y by treating the pulse as a non-smooth disturbance. (6 marks)
- (ii) Determine y by treating the pulse as two counteracting steps. (5 marks)
- (iii) Calculate $y(3)$ by both methods and verify that you get the same answer.

3. (a) What is feedback control? Name the major components in a feedback control block diagram. (4 marks)

(b) Our blending tank under proportional control is represented by the following dynamic system model:

$$\tau_{CL} \frac{dC'_{Ao}}{dt} + C'_{Ao} = K_{CL} C'_{Ai} + K_{SP} C'_{Ao, setpt}$$

$$\text{where } \tau_{CL} = \frac{\tau}{1 + \frac{C_{Ac} K_c}{F}}; \quad K_{CL} = \frac{1}{1 + \frac{C_{Ac} K_c}{F}}; \quad K_{SP} = \frac{\frac{C_{Ac} K_c}{F}}{1 + \frac{C_{Ac} K_c}{F}}$$

You are given the following parameter values:

$$\tau = 300 \text{ s}; \quad C_{Ac} = 400 \text{ kg/m}^3; \quad F = 0.02 \text{ m}^3/\text{s}; \quad K_c = 0.0003 \text{ m}^6/\text{kg s}.$$

Using the integrating factor method for what follows.

- (i) Suppose $C'_{Ao, setpt} = U(t - 100) \text{ kg/m}^3$, calculate the value of C'_{Ao} at $t = 150 \text{ s}$ and $t = 200 \text{ s}$. (10 marks)
- (ii) For the parameters given, determine the values of F'_c at $t = 150 \text{ s}$ and $t = 200 \text{ s}$. (3 marks)
- (iii) What is the offset and the corresponding value of F'_c . (∞). (3 marks)

4. (a) Define a system in process control. (3 marks)

(b) A cylindrical tank having a cross-sectional area of 0.2 m^2 is operating at steady state with an inlet flow rate of $10^{-3} \text{ m}^3/\text{s}$. Between the liquid heads h of 0.3 m and 0.09 m , the flow-head characteristics are given by the equation:

$$F_o = 0.002h + 0.0006 \text{ m}^3/\text{s}$$

where F_o is the outlet flow rate.

Determine the transfer functions relating (i) liquid level and inflow, (ii) outflow and inflow.

(10 marks)

(c) If in part (b) the inflow increases from 10^{-3} to $1.1 \times 10^{-3} \text{ m}^3/\text{s}$ according to a step change, calculate the liquid level 200 s after the change has occurred.

(7 marks)

5. (a) Derive the transfer function $y'(s) / x'(s)$.

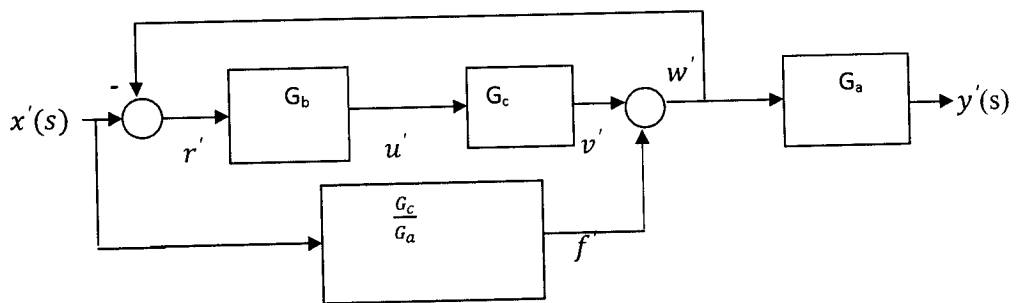

If you designed a device such that $G_a = -1 / G_b$, what would be the response $y'(t)$ to the input $x'(t)$?

(5 marks)

- (b) A system has the following transfer function:

$$\frac{y'_c(s)}{x'_{sp}(s)} = \frac{25(s+1)}{s^2 + 2s+25}$$

Determine $y'_c(0)$, $y'_c(0.6)$ and $y'_c(\infty)$ for a unit step change in set point

(11 marks)

- (c) Suppose in part (b) the transfer function was the following:

$$\frac{y'_c(s)}{x'_{sp}(s)} = \frac{25e^{-2s}(s+1)}{s^2 + 2s+25}$$

Determine $y'_c(3.0)$ for a unit step change in set point.

(4 marks)

6. (a) A second order process with one pole at the origin has the transfer function

$$\frac{y'(s)}{x'(s)} = G(s) = \frac{3}{s(s+1)}$$

Find the output as a function of time for a unit step change in input. What is the ultimate value?

(5 marks)

(b) A unit step change in input temperature is introduced into the following second order system with numerator dynamics:

$$\frac{T'(s)}{T'_1(s)} = \frac{(20s+1)}{(3s+1)(1.5s+1)}$$

- (i) Find $T'(t)$. (7 marks)
- (ii) Determine the ultimate value of $T'(t)$. (2 marks)
- (iii) What is the maximum value of $T'(t)$. (6 marks)

7. A process has an openloop transfer function relating controlled and manipulated variables that is a first-order lag with time constant τ_p with a steady state gain K . There is additional first-order lag with time constant τ_s and steady state gain $K_s=1$ in the measurement (or sensing) of the controlled variable. A proportional only feedback controller is used.

(a) Draw a block diagram of the control system with y'_c as output and y'_{set} as the setpoint. (5 marks)

(b) Derive an expression relating the controller gain K_c to the parameters τ_p, τ_s and K such that the closedloop system damping ratio ζ is 0.707. Keeping ζ at this constant value, what happens to K_c as τ_s gets very small or very large? What is the value of τ_s that provides the minimum value of K_c in terms of τ_p ? (12 marks)

(c) Obtain an expression for the offset for a unit step change in set point. (3 marks)

END OF EXAMINATION IN MM 452

Here is the additional information.

The first-order ODE is as follows:

$$\tau \frac{dy}{dt} + y(t) = K x(t) \quad y(t_0) = y_0$$

The solution is

$$y(t) = y_0 e^{-(t-t_0)/\tau} + \frac{K}{\tau} e^{-t/\tau} \int_{t_0}^t e^{t/\tau} x(t) dt$$

Table of Laplace Transforms

$\frac{f(t)}{U(t)}$	$\frac{f(s)}{\frac{1}{s}}$	$\frac{f(t)}{tU(t)}$	$\frac{f(s)}{\frac{1}{s^2}}$
---------------------	----------------------------	----------------------	------------------------------

$t^n U(t)$	$\frac{n!}{s^{n+1}}$	$e^{-at} U(t)$	$\frac{1}{s+a}$
$t^n e^{-at} U(t)$	$\frac{n!}{(s+a)^{n+1}}$	$\sin kt U(t)$	$\frac{k}{s^2+k^2}$
$\cos kt U(t)$	$\frac{s}{s^2+k^2}$	$\cosh kt U(t)$	$\frac{s}{s^2-k^2}$
$\sinh kt U(t)$	$\frac{k}{s^2-k^2}$	$e^{-at} \cos kt U(t)$	$\frac{s+a}{(s+a)^2+k^2}$
$e^{-at} \sin kt U(t)$	$\frac{k}{(s+a)^2+k^2}$		

Inversion by partial fractions

METHOD 1

Suppose $L\{x(t)\} = x(s) = \frac{F(s)}{(s+k_1+jk_2)(s+k_1-jk_2)}$

where $F(s)$ is some real function of s .

Let the function $x(s)$ after partial fraction expansion become

$$x(s) = F_1(s) + \left(\frac{a_1 + jb_1}{s+k_1+jk_2} + \frac{a_1 - jb_1}{s+k_1-jk_2} \right)$$

where a_1 and b_1 are constants evaluated in the partial fraction expansion and $F_1(s)$ is a series of fractions arising from $F(s)$.

Then the inverse transform arising from the complex root reduces to

$$2e^{-k_1 t} (a_1 \cos k_2 t + b_1 \sin k_2 t)$$

METHOD 2

Suppose $x(s)$ after partial fraction expansion becomes

$$x(s) = F_1(s) + \frac{Bs+C}{(s+a)^2+k^2}$$

Then

$$x(s) = F_1(s) + B \frac{s+a}{(s+a)^2+k^2} + \left(\frac{C-aB}{k} \right) \frac{k}{(s+a)^2+k^2}$$

The inverse transform arising from the above becomes

$$x(t) = F_1(t) + Be^{-at} \cos kt + \left(\frac{C-aB}{k} \right) e^{-at} \sin kt$$

THE UNIVERSITY OF ZAMBIA

SCHOOL OF MINES

UNIVERSITY EXAMINATIONS – APRIL/MAY 2010

MM 542 – FUELS, FURNACES AND REFRACTORIES

TIME: THREE HOURS

ANSWER ANY FIVE QUESTIONS. THE CREDIT FOR A FULL ANSWER IS SHOWN IN BRACKETS BESIDE EACH QUESTION

1. (a) State the three assumptions that you have to make for these calculations [2]
- (b) Define the calorific value of a fuel [2]
- (c) A fuel gas contains 22.4 % CO, 12.6 % CO₂, and 65 % N₂ by volume is burned with the theoretical required amount of air in a furnace designed to heat solids. The gas enters the furnace at 300 °C and leaves it at 750 °C and 1 atm.

Calculate:

- (i) The adiabatic flame temperature, and [10]
- (ii) The quantity of heat supplied to the solids in the furnace, in joules per cubic meter of exhaust gases [6]

Use the following data:

$$(\Delta H^{\circ} 298)_{\text{CO}} = -110\,530 \text{ J/mol}$$

$$(\Delta H^{\circ} 298)_{\text{CO}_2} = -393\,770 \text{ J/mol}$$

Heat – capacity data (in J/g mole. °K)

$$C_{p, \text{CO}_2} = 44.17 + (9.04 \times 10^{-3} T) - (8.54 \times 10^{-5} T^2)$$

$$C_{p, \text{CO}} = 28.43 + (4.10 \times 10^{-3} T) - (0.46 \times 10^{-5} T^2)$$

$$C_{p, \text{N}_2} = 27.88 + (4.27 \times 10^{-3} T)$$

$$C_{p, \text{O}_2} = 29.98 + (4.19 \times 10^{-3} T) - (1.674 \times 10^{-5} T^2)$$

2. (a) State the various classifications of fuels [5]
- (b) What are the main chemical components of fossil fuels [1]
- (c) Calculate the net calorific value of a gas mixture containing 55 % H₂, 35% CO, 5% CH₄, and 5% N₂. The heats of oxidation are -57 800, -67 623 and -191 800 cal/mol respectively. [6]
- (d) Calculate the volume of air required, and the composition of the flue gases when 1 kg of oil is burnt stoichiometrically, where the oil analysis is 80 % C and 20 % H. [8]
3. (a) How is the success of a furnace measured? [2]
- (b) Give a brief description of four classes of furnaces and give examples of the use of furnaces in each of these classes. [4]
- (c) Describe three miscellaneous furnaces [6]
- (d) What are the most important properties of refractories in so far as the user is concerned? [5]
- (e) Describe the most usual classification of refractories which depend on behaviour towards metallurgical slags, using examples. [3]
4. (a) Give a brief description of the following furnaces:
- (i) Hearth Furnaces [2]
- (ii) Shaft Furnaces [2]
- (iii) Converters [2]
- (b) The most important properties of refractory materials generally considered are
- (i) Refractoriness
- (ii) Spalling resistance; and
- (iii) Slag resistance
- Briefly describe the determination of these properties [9]
- (c) Outline the standard route followed in the manufacture of refractories, and show sketches of the firing furnaces used. [5]

5. (a) With the aid of a sketch, describe the important allotropic forms of silica [4]
- (b) Outline four properties of silica [4]
- (c) Draw the $\text{SiO}_2 - \text{Al}_2\text{O}_3$ equilibrium diagram [4]
- (d) Describe the operations of a Multihearth roaster [4]
- (e) Give examples of special refractories and their applications [4]
6. (a) The storage procedures for coal are designed for two purposes, what are they? [2]
- (b) There are several factors that can contribute to the spontaneous combustion of coal, what are they? [3]
- (c) What is meant by carbonisation of coal, and what are its main objectives [3]
- (d) What are the conditions under which coal is carbonised to produce coke? [1]
- (e) The carbonisation of coal is done at two different temperature ranges, what are they and which of the two resulting coke components is used in pig iron manufacture? [2]
- (f) State the commonly used physical tests of coke. [3]
- (g) In the combustion of a solid fuel, draw sketches showing gas analysis and temperature distribution in coke beds of a very un-reactive fuel and a very reactive fuel. [6]

END OF EXAMINATION IN MM 542

THE UNIVERSITY OF ZAMBIA

SCHOOL OF MINES

UNIVERSITY EXAMINATIONS – APRIL/MAY 2010

MM 552 – PROCESS DESIGN

TIME: THREE HOURS

ANSWER ANY FIVE QUESTIONS. ADDITIONAL DATA IS PROVIDED WITH THE QUESTION PAPER

1. (a) Deduce the number of design variables for an isothermal flash distillation. How may they be utilised? (5 marks)
- (b) *Precedence order the following;*
- | | |
|---------------------|--------------------------|
| $f_1(x_1, x_3) = 0$ | $f_1(x_1, x_3) = 0$ |
| (i) $f_2(x_2) = 0$ | (ii) $f_2(x_1, x_2) = 0$ |
| $f_3(x_2, x_3) = 0$ | $f_3(x_3, x_2) = 0$ |

Use the **single node** representation for the order of solution. (6 marks)

- (c) You are working in a laboratory and are requested to melt 100 kg of stainless steel, AISI type 304, with an analysis of 17.5 % Cr, 8.0 % Ni and 0.5 % Mn. Assuming a 10% loss in Ni, calculate the charge you would use for the following available materials:

Material	% Cr	% Ni	%Fe	% Mn
alloyscrap	68	20	10	2
ferrochromium	75		25	
electro Ni		100		
electro Fe			100	

(9 marks)

2. (a) The phase rule for ordinary systems is given as $f = C - P + 2$. Suppose that the equilibrium between phases of a single-component metallic system is affected by the applied magnetic field in addition to the temperature and pressure. Determine the maximum number of phases that can co-exist.

(3 marks)

- (b) Distinguish between internal and external constraints in process or plant design. Give one example of each.

(4 marks)

- (c) The air used to burn S or FeS₂ in making sulphuric acid must first be dried. Passing it counter to a stream of concentrated H₂SO₄ flowing through a packed tower does this. The acid enters the tower at 93 weight percent and is diluted as it absorbs H₂O. Some 92.0 weight percent H₂SO₄ is withdrawn from the system as the acid recycles, and the acid concentration is returned to 93 weight percent by adding 99 weight H₂SO₄.

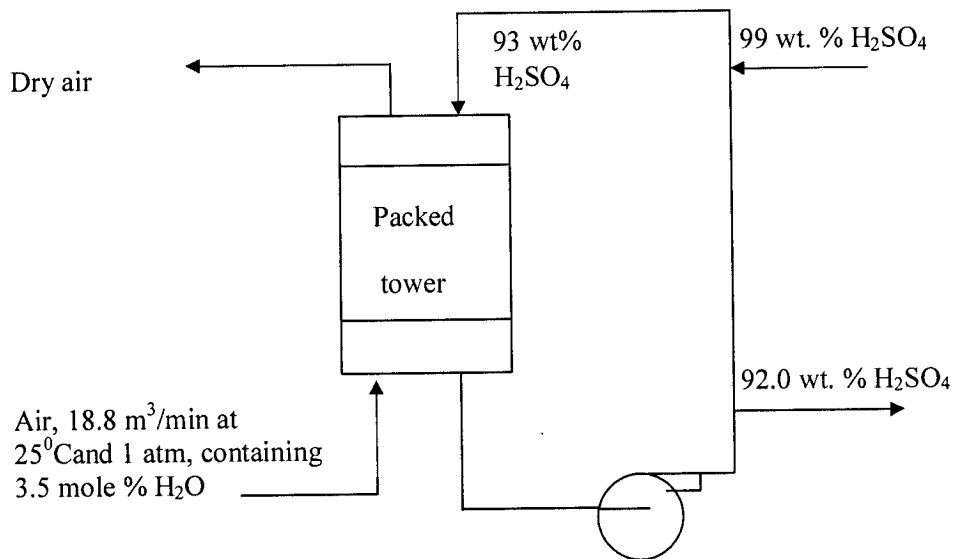

From these data and the flow diagram, calculate

- (i) the mass of 99 weight percent H₂SO₄ in kg added per hour,
(ii) the rate of flow of 93 weight percent H₂SO₄ entering the top of the column in kg/h.

$$R = 8.314 \text{ J/mole.K}$$

$$1 \text{ atm} = 1.013 \times 10^5 \text{ N/m}^2$$

Atomic masses: H, 1; O, 16; N, 14; S, 32.

Use the ideal gas law for the entering air.

(13marks)

3. (a) Synthesis gas containing 63.6% H₂, 9.1% CO₂ and 27.3% CO is to be cooled from 425°C (797°F) to 25°C (77°F). How much heat in MJ/h must be removed if the gas flow rate to the cooler is 600 kmole/h?

(5 marks)

- (b) A furnace burns a liquid coal tar for fuel derived from coke ovens. Calculate the heat transferred (kJ/kg fuel) in the furnace if the combustion gases leave at 1500 K (2200 °F). The burners operate with 20 percent excess air with an average heat capacity of 28.9 kJ/kmol. K. Take the fuel supply temperature as

323 K and the air inlet temperature as 288 K. The heat capacity data of the gases is provided in the figure where 1 cal = 4.180 J.

The properties of the fuel are:

Carbon, 87.5 wt % ; Hydrogen, 8 wt % ; Oxygen, 3.5 wt % ; Nitrogen, 1 wt %.

Net calorific value = 39 540 kJ/kg at 298 K

Latent heat of vaporisation = 350 kJ/kg at 298 K (for H₂O)

Heat capacity = 1.6 kJ/kg.K

Atomic masses: C, 12; H, 1 ; O, 16 ; N, 14 .

Use the specific heat capacity data provided.

$$^{\circ}\text{C} = \frac{5}{9} (^{\circ}\text{F} - 32^{\circ})$$

$$1 \text{ cal} = 4.180 \text{ J}$$

(15marks)

4. (a) Heat is removed from a 20-m³ reactor by feeding cooling through a jacket that surrounds the vessel. The heat removal rate is 3 × 10³ kJ/h. The cooling water inlet and exit temperatures are 21^oC and 37^oC respectively. What is the water flow rate in gallons per minute (gpm)? Take the heat capacity of water as 4.19 kJ/kg.^oC and the density of water as 1000 kg/m³. One gallon (UK) = 4.546 × 10⁻³ m³.

(5 marks)

- (b) In an oil cooler, 216 kg/h of hot oil enters a thin metal pipe of diameter 25 mm. An equal mass of cooling water flows through the annular space between the pipe and a larger concentric pipe; the oil and water moving in opposite directions. The oil enters at 420 K and is to be cooled to 320 K. If the water enters at 290 K, what length of pipe will be required? Take coefficients of 1.6 kW/m².K on the oil side and 3.6 kW/m².K on the water side and 2.0 kJ/kg.K for the specific heat of the oil.

(5 marks)

- (c) A heat exchanger is to be designed to cool 8.7 kg/s of ethyl alcohol solution [$c_{ph} = 3.84 \text{ kJ}/(\text{kg} \cdot ^{\circ}\text{C})$]. This is to be done from 75^oC to 45^oC with cooling water [$c_{pc} = 4.18 \text{ kJ}/(\text{kg} \cdot ^{\circ}\text{C})$] entering the tube side at 15^oC with a flow rate of 9.6 kg/s. The overall heat transfer coefficient based on the outer tube surface is $U_o = 500 \text{ W}/(\text{m}^2 \cdot ^{\circ}\text{C})$. Calculate the heat transfer area for each of the following flow arrangements:

- (i) Parallel flow, shell and tube
- (ii) Counterflow, shell and tube
- (iii) Crossflow, both fluids unmixed.

(10marks)

5. (a) What are design variables and how may they be deduced?

(4 marks)

- (b) Illustrate, with sketches, the temperature profiles of the fluids as a function of the distance along the flow path for a *parallel flow exchanger*, *counterflow exchanger* and a *condenser*. The hot fluid in each case is on the shell side.

(3 marks)

- (c) Engine oil is to be cooled from 353 K to 323 K by using a single-pass concentric-tube heat exchanger with cooling water available at 293 K. Water flows inside a tube with an ID of $D_i = 2.5 \text{ cm}$ at a rate of 0.12 kg/s and oil flows

through the annulus at a rate of 0.16 kg/s. The heat transfer coefficients for the water side and the oil side are 1000 W/m².K and 80 W/m².K respectively. The fouling factors are 5500 W/m².K on the water side and 5500 W/m².K on the oil side. The tube wall resistance is negligible. The specific heats of water and oil can be taken as 4180 J/kg.K and 2090 J/kg.K respectively. External heat losses from the exchanger are to be neglected.

Calculate the tube length for (i) a countercurrent flow arrangement, (ii) a parallel flow arrangement. The equation for the outside heat transfer coefficient is as follows:

$$U_o = \frac{1}{A_o \left[\frac{1}{A_o h_o} + \frac{1}{A_o h_{od}} + \frac{\ln(r_o/r_i)}{2\pi k_w L} + \frac{1}{A_i h_{id}} + \frac{1}{A_i h_i} \right]}$$

(13marks)

6. (a) The purchased and installation costs of some pieces of equipment are given as a function of weight rather than capacity. An example of this is the installed costs of large tanks. The 1998 cost for an installed aluminium tank weighing 90,800 kg was K0.7 billion. For a size range of 90,800 kg to 454,000 kg, the installed cost-weight exponent for aluminium tanks is 0.93. If an aluminium tank weighing 317,800 kg is required, what is the present (2010) fixed capital investment required?

Index in 1998 = 106
 2000 = 108, 100 (change of basis)
 2004 = 110

Assume that the average increase in costs is 2.5 per cent per year.

(6 marks)

- (b) A manufacturing company has found two different machines that will expand its current production. The net cash flows for each machine are as follows:

The initial investment in each case is 1000 million Kwacha.

Year	Cash flow in millions of Kwacha	
	Machine 1	Machine 2
1	500	200
2	500	200
3	100	300
4	0	800

- (i) How many years would it take to pay back the initial investment for machines 1 and 2? For intermediate values, use a linear relationship between years. Which machine would you choose?
- (ii) Calculate the net present worth for each machine at an interest rate of 5%. Which machine would you choose?

- (iii) Show that the discounted-cash-flow rate of return for machine 1 is 6% and that of machine 2 is ~~17.2%~~ 14.3%. Which machine would you choose? (14marks)

- 7.. (a) Discuss the payback time, the discounted-cash-flow rate of return and the net present worth measures of profitability. How would you use these measures to compare alternative investments? (6marks)

- (b) For a project, estimated to last 10 years, revenues from the annual sales and total annual expenses over a three-year period are given in the following table in millions of Kwacha (K'million):

Year	A_s (K'million)	A_{TE} (K'million)
0	0	0
1	400	100
2	500	100
3	500	110

The fixed capital investment, C_{FC} , is 1000 million Kwacha. Plant items have a zero a salvage value. Working capital, C_{WC} , is 90 million Kwacha, and the cost of land, C_L , is 10 million Kwacha. There are no allowances other than depreciation. The fractional rate of tax, t , is 0.50. Using straight-line depreciation accounting and a discount factor of 10 %, calculate

- (i) the annual discounted cash flow, A_{DCF} , for each year,
(ii) the cumulative net present worth (NPV or NPW) at the end of each year. (14marks)

END OF EXAMINATION IN MM 552

THE UNIVERSITY OF ZAMBIA

SCHOOL OF MINES

UNIVERSITY EXAMINATIONS – APRIL/MAY 2010

MM 562 – FOUNDRY

TIME: THREE HOURS

ANSWER ANY FIVE QUESTIONS AND ALL CARRY EQUAL MARKS

1. (a) Explain how hot spots lead to the formation of cavities at casting junctions such as the L and T type junctions and show how the two junctions may be re-designed to prevent the formation of hot spots.

[8]

- (b) Using a table format and with reference to four causes of porosity in castings, explain how those four cause porosity in castings and what remedies are applicable to deal with them.

[12]

2. (a) A Ge-Ga crystal is grown by normal freezing. Initial melt composition is 20 ppm Ga. Growth rate is 16×10^{-3} cm/sec. Assume that $k = 0.15$, $m_L = -6$ deg C/ % and $D_L = 8 \times 10^{-5}$ cm² /sec. If convection is completely absent, what thermal gradient is required to maintain a plane front when the ingot is 65 % solidified?

[15]

$$\frac{G_L}{R} \geq \frac{-m_L C_S}{k D_L} (1 - k)$$

- (b) How is the feed capacity utilisation of feeder heads for castings assessed and make reference to the common types of feeder heads used.

[5]

3. (a) Use the Bernoulli's relation to determine dimensions of a top poured gating system for the production of a casting that weighs 4 tonnes with a specific gravity of 7.65 if the flow of metal in the system is $4.5 \times 10^{-4} \text{ m}^3/\text{sec}$ and the total potential energy is equivalent to 0.045 m. [10]

(b) Calculate the pouring time of a 140 x 270 x 510 mm casting using a 25.4 mm x 25.4 mm ingate and a constant head of 140 mm. Neglect orifice and frictional effects. [10]

4. (a) From the equation that governs homogeneous or heterogeneous solidification in alloys and given as below show how the critical free energy is arrived at if ΔG_v is also $(L \cdot \Delta T) / T_m$ [12]

where $L =$ latent heat of fusion

$T_m =$ equilibrium melting temperature

$\Delta T = (T_m - T)$

$$\Delta G = - \frac{4 \pi r^3 \Delta G_v}{3} + 4 \pi r^2 \gamma$$

and giving appropriate illustrations

(b) Explain the role (concept) of the contact angle in heterogeneous nucleation. Is the critical radius different in the case of homogeneous and heterogeneous nucleation? [8]

5. (a) In the laboratory casting of a pump impeller and mechanical test pieces, how did the as cast properties of the two (impeller and test pieces) compare? [7]

(b) Explain and give reasons why the chemical composition varied (if at all) from the charge material to the melt prior to casting and in the final cast pieces. [7]

- (c) Suggest what sort of properties the buyer of the impeller (for whom the casting was being done) would specify in the final product and give reasons why. [6]
6. (a) Show how solidification would progress in an alloy where there is no diffusion in the solid but perfect mixing in liquid. Using the Scheil equation given below for material balance during solidification, show that the solute composition $C_s = k C_o (1 - f_s)^{(k-1)}$ stating boundary conditions and other assumptions. [14]

$$(C_L - C_s) df_s = (1 - f_s) dC_L$$

$(1 - f_s)$ = volume fraction of liquid remaining

f_s = volume fraction solidified

- (b) What is solidification time in casting a function of and show how it is related to the volume and surface area of a casting. What would be the best shape to cast from in terms of the pouring basin. [6]

END OF EXAMINATION IN MM 562

(c) Suggest what sort of properties the buyer of the impeller (for whom the casting was being done) would specify in the final product and give reasons why. [6]

6. (a) Show how solidification would progress in an alloy where there is no diffusion in the solid but perfect mixing in liquid. Using the Scheil equation given below for material balance during solidification, show that the solute composition $C_s = k C_o (1 - f_s)^{(k-1)}$ stating boundary conditions and other assumptions. [14]

$$(C_L - C_s) df_s = (1 - f_s) dC_L$$

$(1 - f_s)$ = volume fraction of liquid remaining

f_s = volume fraction solidified

(b) What is solidification time in casting a function of and show how it is related to the volume and surface area of a casting. What would be the best shape to cast from in terms of the pouring basin. [6]

END OF EXAMINATION IN MM 562