

THE UNIVERSITY OF ZAMBIA
SCHOOL OF AGRICULTURAL SCIENCES
2020/2022 ACADEMIC YEAR

1. AGA 2110: Anatomy and Physiology of Farm Animals
2. AGA 2110: Anatomy and Physiology of Farm Animals
3. AGA 3212: Applied Animal Nutrition
4. AGA 3212: Applied Animal Nutrition
5. AGA 4511: Beef, Sheep and Goat Production
6. AGA 4522: Dairy and Rabbit Production
7. AGA 4522: Dairy and Rabbit Production
8. AGA 4531: Introduction to Aquaculture
9. AGA 4532: Pig and Poultry Production
10. AGA 4532: Pig and Poultry Production
11. AGA 4552: Animal Products and By-Products
12. AGA 5121: Advances in Animal Nutrition
13. AGA 5321: Applied Animal Reproduction
14. AGA 5562: Integrated Aquaculture and Fish Nutrition
15. AGA5562: Integrated Aquaculture and Fish Nutrition
16. AGA 5712: Animal Health
17. AGA 6132: Vitamins and Minerals Metabolism
18. AGA 6142: Proteins and Amino Acids Metabolism
19. AGC 2110: Fundamentals of Plant Science
20. AGC 3135: Fundamentals of Plant Science
21. AGC 3135: Fundamentals of Plant Science
22. AGC 3412: Introductory Horticulture
23. AGC 4320: Principles and Application of Entomology
24. AGC 5125: Sustainable Agriculture
25. AGC 5220: Plant Breeding and Quantitative Genetics
26. AGC 5421: Advanced Horticulture
27. AGC 5612: Seed Science and Technology
28. AGC 5712: Post Harvest Technology
29. AGE 2111: Fundamentals of Micro-Economics
30. AGE 2122: Fundamentals of Macro-Economics
31. AGE 3031: Intermediate Micro-Economics
32. AGE 3042: Intermediate Macro-Economics
33. AGE 3381: Research Methodology

34. AGE 4131: Production Economics
35. AGE 4142: Agricultural Marketing and Pricing
36. AGE 4222: Intermediate Agribusiness Management
37. AGE 4311: Quantitative Methods in Agricultural Economics
38. AGE 4322: Applied Econometrics
39. AGE 5151: International Agricultural Markets, Trade and Development
40. AGE 5151: International Agricultural Markets, Trade and Development
41. AGE 5162: Agricultural Finance
42. AGE 5172: Agricultural Policy Analysis
43. AGE 5253: Agricultural Project Planning and Appraisal
44. AGE 5262: Intermediate Farm Management
45. AGE 5272: Project Monitoring and Evaluation
46. AGE 5451: Advanced Aspects of Rural Sociology
47. AGE 6322: Applied Econometrics
48. AGF 2251: Fundamentals of Electrical Engineering for Food Science
49. AGF 2262: Fundamentals of Engineering Drawing
50. AGF 2401: Introduction to Information Technology and Communication
51. AGF 3042: Instrumental Methods in Food Analysis
52. AGF 3042: Instrumental Methods in Food Analysis
53. AGF 3100: General and Food Microbiology
54. AGF 3100: General and Food Microbiology (Practical)
55. AGF 3100: General and Food Microbiology (Theory)
56. AGF 4052: Sensory Evaluation of Foods
57. AGF 4210: Food Engineering
58. AGF 4221: Process Control and Instrumentation
59. AGF 5071: Food Colloids
60. AGF 5071: Food Colloids
61. AGF 5321: Technology of Dairy and Egg Products
62. AGF 5432: Food Safety and Quality Management
63. AGF 5615: Processing and Preservation of Plant Products
64. AGF 5625: Processing and Preservation of Animal Products
65. AGF 6321: Advanced Food Engineering
66. AGF 6432: Advanced Technology of Meat, Poultry and Fish
67. AGF 6442: Advanced Technology of Fruits and Vegetables
68. AGG 3811: Rural Sociology
69. AGG 3822: Agricultural Extension
70. AGG 3832: Forage Crop Production and Range Management
71. AGG 3842: Introductory Statistics for Agriculture
72. AGG 3842: Introductory Statistics for Agriculture
73. AGG 4851: Experimental Design and Statistical Analysis

74. AGG 4851: Experimental Design and Statistical Analysis
75. AGG 6811: Biostatistics
76. AGN 2110: Fundamentals of Human Anatomy and Physiology
77. AGN 2212: Principles of Human Nutrition
78. AGN 3232: Principles of Dietetics
79. AGN 3232: Principles of Dietetics
80. AGN 3510: Nutrition Communication and Health Promotion
81. AGN 4122: Nutrient and Drug Interactions
82. AGN 4410: Diet Formulation and Dietetic Management
83. AGN 4520: Public Health Nutrition
84. AGN 5432: Hospital Dietary Management
85. AGN 5442: Obstetrics and Paediatric Nutrition
86. AGN 5452: Nutrition in General Medicine
87. AGN 5462: Nutrition in Oncology, Trauma and Surgery
88. AGN 5542: World Food Issues
89. AGN 6111: Advanced Metabolism
90. AGN 6210: Biostatistics and Research methods
91. AGN 6410: Socioeconomic Dimensions of Nutrition
92. AGS 2110: Fundamentals of Soil Science
93. AGS 2110: Fundamentals of Soil Science
94. AGS 3312: Soil Physics
95. AGS 3312: Soil Physics
96. AGS 3711: Agroclimatology
97. AGS 4210: Soil Mineralogy and Chemistry
98. AGS 4210: Soil Mineralogy and Chemistry
99. AGS 4232: Soil Fertility and Amendments
100. AGS 4232: Soil Fertility and Amendments
101. AGS 5511: Agriculture Hydraulics and Irrigation
102. AGS 5522: Management of Irrigation and Drainage Systems
103. AGS 5612: Integrated Land Husbandry



THE UNIVERSITY OF ZAMBIA
SCHOOL OF AGRICULTURAL SCIENCES
DEPARTMENT OF ANIMAL SCIENCE

AGA 2110: ANATOMY AND PHYSIOLOGY OF FARM ANIMALS
SUPPLEMENTARY EXAMINATION - FEBRUARY 2022

INSTRUCTIONS:

- ANSWER EACH SECTION IN A SEPARATE ANSWER BOOKLET
 - ANSWER ANY THREE (3) QUESTIONS
 - CLEARLY WRITE THE NUMBER OF EACH ATTEMPTED QUESTION
 - START EACH QUESTION ON A NEW PAGE
 - ALL QUESTIONS CARRY EQUAL MARKS (20 MARKS).
-

SECTION A

QUESTION ONE

A. Write short notes on the following terms as they are used in farm animals;

- (a) Pampiniform plexus (2 Marks)
- (b) Number and position of mammary glands in sheep and cattle (2 Marks)
- (c) Physiological buffers (2 Marks)
- (d) Acrosome Reaction (2 Marks)
- (e) oocyte (2 Marks)

B. Briefly explain the following phenomena;

- (a) Alveoli (2 Marks)
- (b) Spermatogenesis (5 Marks)
- (c) Keratinocyte (1 Marks)
- (d) Hormone (1 Marks)
- (e) Blood testis barrier (1 Marks)

QUESTION TWO

- (a) State four functions of the nervous system. (4 Marks)
- (b) Briefly explain the gross anatomical sections of lungs as seen in the bovine (6 Marks)
- (c) Draw and clearly label the main features of a graafian follicle (8 Marks)
- (d) Name the functions of the nephron (2 Marks)

SECTION B

QUESTION THREE

- A. Mention the four (04) types of tissue found in an animal's body and state one general role of each the tissues. (4 marks)
- B. Briefly describe the connective tissue wrappings of skeletal muscle and give an indication of their relative locations (6 marks)
- C. An animal's body is segmented into body cavities
- What are the four (04) general roles of body cavities (4 marks)
 - Mention any two (02) body cavities and list one organ that is located in that body cavity (4 marks)
 - Mention the specific epithelial membranes that line the body cavities mentioned in (ii). (2 marks)

QUESTION FOUR

- A. Farm animals are categorised into 4 groups based on the anatomy of the digestive system. Mention 4 groups or categories (4 Marks)
- B. Explain the anatomical differences in the gastrointestinal track and list one species that belongs to each category. (12 Marks)
- C. Explain how the anatomy is related to the diet of the animals (4 marks)

GOOD LUCK

BONNE CHANCE



THE UNIVERSITY OF ZAMBIA
SCHOOL OF AGRICULTURAL SCIENCES
DEPARTMENT OF ANIMAL SCIENCE

AGA 2110 ANATOMY AND PHYSIOLOGY OF FARM ANIMALS

FINAL EXAMINATION- NOVEMBER 2022

INSTRUCTIONS:

- ANSWER ANY FIVE QUESTIONS
- ANSWER EACH SECTION IN A SEPARATE ANSWER BOOKLET
- CLEARLY WRITE THE NUMBER OF EACH ATTEMPTED QUESTION
- START EACH QUESTION ON A NEW PAGE
- ALL QUESTIONS CARRY EQUAL MARKS (20 MARKS).

SECTION A

QUESTION ONE

A. Write short notes on the following terms as they are used in farm animals;

- i. Hormone (2 Marks)
- ii. Stratum corneum (2 Marks)
- iii. Physiological buffers (2 Marks)
- iv. Zona pellucida (2 Marks)
- v. Parenchyma of mammary glands (2 Marks)

B. Briefly explain the following phenomena;

- i. Milk ejection reflex (2 Marks)
- ii. Leucocytes (5 Marks)
- iii. Foramen ovale (1 Marks)
- iv. Hormone (1 Marks)
- v. Blood testis barrier (1 Marks)

QUESTION TWO

- i. Briefly discuss the source(s) and route(s) of loss for electrolytes in livestock. (6 Marks)
- ii. What two glands are considered accessory to the male reproductive system? (2 Marks)
- iii. Draw and clearly label the main features of the bovine female reproductive system (8 Marks)
- iv. Briefly explain the functions of two components of the cardiovascular system (2 Marks)
- v. Briefly explain two adaptations of the respiratory system? (2 Marks)

QUESTION THREE

With regard to farm animals,

- i. Use a well-illustrated diagram to show the functions of a nephron (10 Marks)
- ii. Describe two mechanisms for thermoregulation in the testes (4 Marks)
- iii. What is the role of melanocytes? (2 Marks)
- iv. What are types of respiration? (4 Marks)

SECTION B

QUESTION FOUR

- i. A sarcomere is the smallest functional unit of striated muscle tissue. It is composed of two main protein filaments which slide past each other during contraction. Draw a simple sketch of a sarcomere, showing how the protein filaments are arranged and label the different regions (6 marks)
- ii. Briefly explain the changes that occur to the different parts and regions of the sarcomere during muscle contraction (4 marks)
- iii. List four (04) roles that bones play in the body of an animal (2 marks)
- iv. Bones are classified into 4 classes based on the shape. List the four classes and for each category, mention one bone that belongs to that category (8 marks)

QUESTION FIVE

- i. Briefly explain the three (03) basic functions of the nervous system. (6 marks)
- ii. What are the anatomical sites of origin for the sympathetic and parasympathetic nervous systems (2 marks)
- iii. Differentiate the sympathetic and parasympathetic nervous systems by the circumstances under which they are activated, state any five (05) target organs and their effects on the target organs (12 marks)

QUESTION SIX

- i. What are the four (04) principle functions of the digestive system (4 marks)
- ii. Farm animals are categorized into four classes according to the anatomy the gastrointestinal tract. Mention the four categories (4 marks)
- iii. State the anatomical differences among the four classes (8 marks)
- iv. For each of the categories, list one species that belongs to each category and mention its main diet (4 marks)

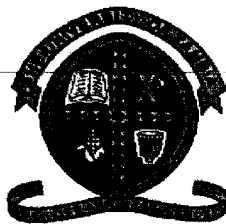

THE UNIVERSITY OF ZAMBIA
SCHOOL OF AGRICULTURAL SCIENCES
DEPARTMENT OF ANIMAL SCIENCE

2021/2022 END OF THE YEAR EXAMINATIONS
AGA 3212 – APPLIED ANIMAL NUTRITION

INSTRUCTIONS TO CANDIDATES

Answer ANY FIVE questions from the six provided

Use a separate answer booklet for each section

Read the questions carefully before attempting

All questions carry equal Marks (20 Marks)

SECTION A – LIVESTOCK AND POULTRY FEED INGREDIENTS

QUESTION ONE

- (a) Hay and silage are preserved roughages for ruminant feeding. Write briefly on the characteristics of good quality hay and good quality silage, respectively. (8 marks)
- (b) List three types of soybean meal available on the Zambian market for livestock feeding. Briefly describe their differences in nutritive value. (12 marks)

QUESTION TWO

Wheat grain, sorghum grain, sweet potato tubers and cooking oil can all be used as energy feedstuffs in animal feeding. For each of these feedstuffs discuss the factors that limit their optimal use in non-ruminant feeding. (20 marks)

QUESTION THREE

- (a) Define the term 'concentrates' as used in livestock feeding. How are concentrates classified? (5 marks)
- (b) Explain the difference between 'meat meal' and 'meat and bone meal'. (5 marks)
- (c) Write briefly on the advantages and disadvantages of adding urea to ruminant feed. (5 marks)
- (d) What is antibiotic resistance and how does it occur? (5 marks)

SECTION B – RATION FORMULATION

QUESTION FOUR

- (a) Using simultaneous equations, formulate a 100Kg feed ration with 22% CP. The ingredients to use are Maize meal (8.8% CP, 0.05% Ca, and 0.26% P), Soybean meal (45% CP, 0.30% Ca, and 0.59% P), Wheat bran (14.7% CP, 0.09% Ca, and 0.23% P), Fish meal (65% CP, 2.2% Ca, and 1.80% P), DCP (0% CP, 24% Ca and 18.2% P) and Salt (0% CP, 0% Ca and 0% P). The inclusion levels of wheat bran, fish meal, DCP and salt should be limited to 6, 10, 1.6 and 0.5% respectively. (16 Marks)
- (b) What is the Ca and P content of the ration formulated in (A)? (4 Marks)

QUESTION FIVE

Formulate a 100Kg Broiler concentrate to be mixed with 300kg of maize to make a complete diet with 18% CP, 0.65% Ca, 0.4% P, 0.5% Salt, 0.5%, 0.1% Zinc Bacitracin and 1.0% Broiler premix, using SBM, DCP, Limestone flour, salt, broiler premix, Zinc Bacitracin. Use maize as a carrier. The composition of the ingredients is as shown in the Table below. (20 Marks)

Ingredient	Crude Protein (g/Kg DM)	Calcium (g/kg DM)	Phosphorus (g/kg DM)
Maize meal	90	0.5	2.7
Soybean meal	450	2.6	6.1
Fish meal	700	22	1.7
DCP	0	240	180
Limestone flour	0	370	0
Salt	0	0	0
Broiler premix	0	0	0
Zinc bacitracin	0	0	0

QUESTION SIX

Using Algebraic equations, formulate a complete broiler starter ration with 22% CP, 1% Ca and 0.65% P, using ingredients shown in the Table below;

Ingredient	Protein %	Calcium (%)	Phosphorus (%)
Maize meal	8.8	0.05	0.27
Wheat bran	15.4	0.13	1.13
Full fat -SBM	38.9	0.26	0.61
Fish meal	70.1	2.19	1.67
DCP	0	24.0	18.2
Limestone flour	0	37.1	0
Salt	0	0	0
Broiler premix	0	0	0
Antibiotic Agent	0	0	0

The wheat bran should be limited to 5%, fish meal at 10%, salt and premix at 0.5% each, while the antibiotic agent, DL-Methionine and Lysine should be 0.1, 1.02 and 0.45%, respectively. (20 Marks)



**THE UNIVERSITY OF ZAMBIA
SCHOOL OF AGRICULTURAL SCIENCES
DEPARTMENT OF ANIMAL SCIENCE**

2020/2021 SUPPLEMENTARY EXAMINATIONS

AGA 3212 – APPLIED ANIMAL NUTRITION

INSTRUCTIONS

Read the questions carefully before attempting questions

Answer ANY THREE questions from the four provided

Write your answers for questions in each section in a separate booklet

All questions carry equal marks (20 Marks each)

SECTION A

QUESTION ONE

- (i) What are nutrients? Of all nutrients that you know, list down three of them, and explain at least three functions that each one of them has in the body of an animal **(10 Marks)**
- (ii) Blood meal is known to be a good source of protein. However it is not much used in stock feeds, and when used it may be used in restricted amounts. Explain at least two reasons that you consider to be the main contributing factors to this state of affairs. **(5 Marks)**
- (iii) Of all protein sources, describe at least two nutritional characteristics of two protein ingredients that you know, which are used in diets for monogastric animals **(5 Marks)**

QUESTION TWO

- (a) Using simultaneous equations, formulate a 100kg feed ration with 20% CP. The ingredients to use are maize with 8.8% CP, Soybean meal with 44.7% CP, Wheat bran with 14.7% CP, and Fish meal with 63.1% CP. Inclusion levels of Wheat bran and fish meal should be limited to 6 and 10%, respectively **(16 Marks)**
- (b) Show proof that your feed ration contains 20% CP **(4 Marks)**

SECTION B

QUESTION THREE

A). Explain the steps you may wish to take to ensure the ruminants under your care have adequate supply of feed during the dry season **(8 Marks)?**

B). Assume you have a herd of beef cattle consisting of 2 oxen, a bull, 6 cows, 4 two-year old replacement heifers, 3 one-year old replacement heifers and 4 calves that are less than 3 months old. If a bull and the oxen are equivalent to 1.2 livestock Units, a cow to 1.0 livestock unit, a two-year old replacement heifer to 0.8 livestock unit, a one-year old replacement heifer is 0.5 LU and calves under 3 months are equivalent to 0.3 LU. How many livestock units are in this herd and how much feed do these animals consume in a day **(6 Marks)?**

C). Assuming you have a plot for growing food and pasture crops as tabulated in Table 1. How long will the fodder from the farm plot last on the farm to feed animals in question 1A? How many tones of hay on as fed basis are you supposed to buy for the animals to have adequate feed supply for a five month feeding period; assuming the required hay has 74% dry matter (6 Marks)?

Table 1: Expected fodder production from on-farm crop production operations

Crop	Hectares	Type of fodder	Expected Yield	DM Content
Maize	2.0	Stover	3.0 tons/ha	80%
Siratro	2.0	Hay	1.5 tons/ha	75%
Soy bean Straw	3.0	Straw	1.0 tons/ha	73%
Star grass	3.0	Hay	2.0 tons/ha	70%
Lucerne	1.5	Hay	1.2 tons/ha	65%

QUESTION FOUR

A). What is feed supplementation and why do we have to give animals in our care supplementary feeds (8 Marks)?

B). A). Assume you have a 400kg dairy cow that is producing milk with 4.0% butter fat content and the animal depends on a 3 : 1 grass and legume hay mixture. The grass is said to have 60% Dry matter and contains 700g TDN and 60 g digestible crude protein (dCP) per kg dry matter. On the other hand, the legume is said to have 55% dry matter and contains 600g TDN and 120 g (dCP) per kg DM. If the cow consumes 3.0% of its body weight as daily DM intake, how much of the hay mixture is this animal expected to consume each day on as fed basis? What are the energy (TDN) and digestible crude protein (dCP) concentrations in the hay mixture when expressed on as fed basis? How much milk per day is this animal expected to produce by consuming the calculated amounts of hay mixture considering the maintenance and milk production requirements are as tabulated in Table 2 (12 Marks)?

Table 2: Nutrient requirements for maintenance and milk production in dairy caws

Maintenance requirements per day			Milk production requirements per litre		
Weight (kg)	TDN (g)	dCP (g)	Butter fat (%)	TDN (g)	dCP (g)
350	3400	270	3.5	415	51
400	3700	290	4.0	470	56
450	4300	310	4.5	530	63



THE UNIVERSITY OF ZAMBIA
THE SCHOOL OF AGRICULTURAL SCIENCES

UNIVERSITY DEFERRED/SUPPLEMENTARY EXAMINATIONS – FEBRUARY 2022

COURSE AGA 4511 – Beef, Sheep and Goat Production

Time allowed: Two (2) hours only

Marks: 60

INSTRUCTIONS TO CANDIDATES:

- i. Answer any **three (3)** questions, **at least one (1) from each Section.**
 - ii. All Questions carry equal marks (20).
-

SECTION A – BEEF PRODUCTION

Q. 1 a. Define the following terms used in beef production:

- i. Bull
- ii. Heifer
- iii. Sire
- iv. cow
- v. In-calf
- vi. Dam

(6 marks)

b. Outline the characteristics of local tropical breeds of cattle that make them to be more adapted to the local environment compared to the exotic European breeds

(14 marks)

Q. 2 Zambia's ability to capture the potential economic benefits of expanded beef industry is constrained by gaps in productivity and price competitiveness. The beef industry in Zambia has great potential to becoming a major foreign exchange contributor to the national treasury.

a. Give reasons as to why the beef industry has great potential for growth in Zambia.

(10 marks)

b. What would it take for the industry to achieve this potential?

(10 marks)

- Q.3 In beef production, it is important to always remember that a Bull is half the herd.
- Explain the meaning of this statement.
(6 Marks)
 - What the important factors to consider when selecting a bull for breeding?
(8 marks)
 - When is the best time to first serve heifer and why at this time?
(6 Marks)

SECTION B – SHEEP AND GOAT PRODUCTION

- Q. 4 A farmer group comprising of traditional, extensive and intensive producers in Katete District of the Eastern Province has been convinced to start sheep and goat enterprises in order to meet the high demand for mutton and chevon in the District; in Zambia and for possible export to neighbouring countries. As a sheep and goat expert, prepare detailed notes for a presentation to the farmer group on the breeding seasons of sheep and goats that are currently used in Zambia.
(20 marks)
- Q. 5 Having been recently appointed as the Farm Manager of an intensive sheep and goat enterprise at UNZA's Liempe Farm, the Vice Chancellor has learned that one of the routine management practices in sheep and goat production is to wean lambs and kids at 5 months of age, discuss in detail with the Vice Chancellor any other ten (10) routine management practices that you intend to put in place to ensure that the sheep and goat enterprise operates profitably.
(20 marks)

End of Examination

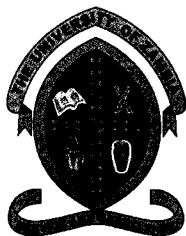

THE UNIVERSITY OF ZAMBIA

UNIVERSITY DEFERRED/SUPPLEMENTARY EXAMINATIONS – FEBRUARY 2022

AGA 4522 - DAIRY AND RABBIT PRODUCTION

Time allowed: Two (2) hours

Marks: 60

INSTRUCTIONS TO CANDIDATES:

- i. Answer any **three (3)** questions, **at least one from each section**.
 - ii. All Questions carry equal marks (20).
-

SECTION A – Dairy Cattle Production

- Q. 1** a. Define each of the following terms used in beef and dairy production;
- i. Oestrus synchronization **(2 Marks)**
 - ii. Super ovulation **(2 Marks)**
 - iii. Pasture mating **(2 Marks)**
 - iv. Cryopreservation **(2 Marks)**
- b. List down at least four (4) disadvantages of servicing a heifer that has shown heat signs for the first time **(8 Marks)**
- c. Explain at least two distinguishing characteristics of Jersey and Guernsey breed of dairy cattle **(4 Marks)**
- Q. 2** a. An orphaned dairy calf to be artificially reared should have access to colostrum milk within the first 12 hours of its life. Give three (3) reasons, why this milk is important to a calf. **(12 Marks)**
- b. List down any four (4) advantages of embryo transfer. **(8 Marks)**

SECTION B – Dairy Goat and Rabbit Production

- Q. 3** Milk is produced and stored in the doe's udder. However, the doe must be stimulated in order to let down her milk. Once the dairy goat has been

stimulated to let-down her milk, proper and efficient methods to remove the milk from the doe's udder should be used. Write detailed notes on the following:

- i. The milk let down process and explain why it is necessary to milk the dairy doe quietly; and

(10 marks)

- ii. The different techniques that may be used to remove the milk from the doe's udder on a goat dairy farm of your choice.

(10 marks)

- Q. 4**
- a. Selection is the process of choosing certain individual dairy goats as parents of the next generation in preference to others. Selection tends to improve the average performance of the flock of dairy goats. Discuss in detail the desirable dairy characteristics that should be routinely selected for in a flock of Saanen dairy does with an emergent farmer from Mumbwa District.

(10 marks)

- b. Discuss in detail with the emergent farmer from Mumbwa District any ten (10) breeding routine management practices that he/she should introduce in a rabbit unit for maximum profits.

(10 marks)

- Q. 5**
- An emergent farmer from Mumbwa District wishes to establish a rabbit unit on his one (1) hectare small land holding after learning that good rabbit breeding routine ensures that the bucks and does are healthy, produce healthy litters and that the growers are well fattened before marketing.

- a. Design an individual rabbit Hutch Breeding Record Card to assist the emergent farmer from Mumbwa District have a proper record keeping system in his/her rabbit unit; and

(10 marks)

- b. Discuss in detail with the emergent farmer from Mumbwa District any five (5) factors that may affect feed intake among his/her rabbits.

(10 marks)

End of Examination



THE UNIVERSITY OF ZAMBIA
UNIVERSITY END OF YEAR EXAMINATIONS – NOVEMBER 2022

AGA 4522 - DAIRY AND RABBIT PRODUCTION

Time allowed: Three (3) hours

Marks: 100

INSTRUCTIONS TO CANDIDATES:

- i. Answer any **five (5)** questions, **at least two (2)** from each section.
 - ii. All Questions carry equal marks (20).
-

SECTION A – Dairy Cattle Production

- Q. 1** a. Explain why it is important to dry off a cow at least two months before calving and what the steps that you may wish to undertake to successfully dry off a cow after ten (10) months of lactation?
(12 Marks)
- b. Explain how you would prepare a cow for calving and what are some of the signs that would tell that the cow is about to give birth and explain how you would manage a newly born calf? **(8 Marks)?**
- Q. 2** a. What is dairy hygiene and how would you ensure that the milk produced from your farm is of good quality that is acceptable to all consumers?
(10 Marks)
- b. What are the key quality characteristics of milk produced from cows and how would you go about in testing the milk to ensure it meets the said quality characteristics?
(10 Marks)
- Q. 3** a. What is biosecurity and what steps would you need to follow for you to implement a viable bio-security regime on your farm for effective prevention and control of animal diseases?
(12 Marks)
- b. What are the major sources of milk contamination and explain the steps that must be followed to ensure you produce milk that is free of physical and microbial contamination on the farm? **(8 Marks)**

SECTION B – Dairy Goat and Rabbit Production

- Q. 4** Milk is produced and stored in the dairy goat's udder. However, the dairy goat must be stimulated in order to let down her milk. Once the dairy goat has been stimulated to let-down her milk, proper and efficient methods to remove the milk from the doe's udder should be used.

- i. What understand by the term 'the milk let-down process'? **(2 marks)**
- ii. Explain why it is important to quietly milk the dairy goat. **(3 marks)**
- iii. Discuss the different techniques that may be used to remove the milk from the dairy goat's udder. **(15 marks)**

Q. 5 a. Selection is the process of choosing certain individual dairy goats as parents of the next generation in preference to others. Selection tends to improve the average performance of the flock of dairy goats. As the farm manager, discuss in detail the desirable dairy characteristics that you would routinely selected for in a flock of Saanen dairy goats.

(10 marks)

b. Discuss any five (5) factors that may reduce the conception rate among does in a rabbit unit of your choice.

(10 marks)

Q. 6 Mr. Mazuba has just learned that rabbits are a cheap source of meat for his household. He has also learned that rabbits are small, cheap to purchase and to house. Therefore, the initial capital outlay to start a rabbit production enterprise is minimal. He has also learned that a rabbit hutch can be constructed with the use of some scrap wood or bamboo and the rabbit unit can set up in a disused garage. Prepare for Mr. Mazuba detailed notes on any other ten (10) reasons to convince him to establish a rabbit unit on his five (5) hectare farm land in Lusaka West.

(20 marks)

End of Examination

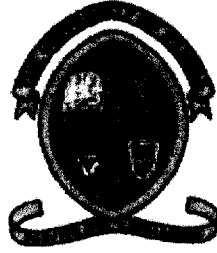

**THE UNIVERSITY OF ZAMBIA
UNIVERSITY SUPPLEMENTARY EXAMINATIONS –
FEBRUARY 2022**

**AGA 4531
INTRODUCTION TO AQUACULTURE**

DURATION: 2 HOURS

15/02/2022 (am)

INSTRUCTIONS:

- 1) There are two sections in this paper, Section A and Section B.
- 2) Section A has ONE (1) question. This question is **COMPULSORY**.
- 3) Section B has three (3) questions, **answer any TWO (2) questions in this section.**
- 4) Start answering each question on a separate page.
- 5) Make sure to write your computer number on each page of your answer sheet.

SECTION A (This section is compulsory)

1. Explain the following terms as applied in the course Introduction to Aquaculture: [20 marks total]

- | | |
|-----------------------------------|-----------|
| a. Biological Oxygen Demand (BOD) | [2 marks] |
| b. Systematics | [2 marks] |
| c. Swim bladder | [2 marks] |
| d. Dioecious | [2 marks] |
| e. Oviparous | [2 marks] |
| f. Catadromous migration | [2 marks] |
| g. Brackish water culture | [2 marks] |
| h. Taxonomy | [2 marks] |
| i. Poikilothermic | [2 marks] |
| j. Plankton | [2 marks] |

SECTION B (Choose any TWO (2) questions)

1. Answer the following; [20 marks in total]

- (a) Discuss the types of fish migration which occurs on the basis of needs. (10 marks)
- (b) List five (5) examples of common fish families and name any fish that belong to each family given. (10 marks)

2. Transportation of live fish must be carefully done in order to be successful. A poorly organized effort may easily result in death of fish.

Answer the following questions: [20 marks in total]

- (a) Discuss the factors that directly influence fish transportation (10 marks)
- (a) Explain any six (6) causes of fish mortality during live fish transportation. (6 marks)
- (c) What are three functions of sedatives in live fish transportation? Give one example of a sedative. (4 marks)

3. Fish biology is important in understanding how best to maximize growth of fish. Answer the following questions: [20 marks in total]

- a) Explain how the process of gaseous exchange is achieved in fish. (6 marks)
- b) What are the four (4) sensory organs that are prominent in fish? (4 marks)
- c) Omnivorous fish eat a mixture of various natural foods, although most of them have preferences for certain foods. Give one (1) example of fish which has preference for each of the following:
 - i. Zooplankton [2 mark]
 - ii. bottom fauna [2 mark]
 - iii. bottom detritus [2 mark]
 - iv. phytoplankton [2 mark]
 - v. fruits and seeds [2 mark]

**END OF EXAMINATION
GOOD LUCK!**

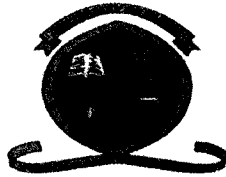

UNIVERSITY OF ZAMBIA
SCHOOL OF AGRICULTURAL SCIENCES
DEPARTMENT OF ANIMAL SCIENCE

AGA 4532- PIG & POULTRY PRODUCTION
SUPPLEMENTARY EXAMINATION
FEBRUARY 2022

INSTRUCTIONS:

1. There are **TWO SECTIONS** in this paper
 2. Answer all **FOUR QUESTIONS**
 3. Use a separate answer booklet for each section
-

SECTION A – POULTRY PRODUCTION

QUESTION ONE

Explain with at least two reasons the importance of each of the following in poultry management

- (i) Egg candling (4 Marks)
- (ii) Mating ratio in parent stocks (4 Marks)
- (iii) Electrolytes or vitamins in brooding management (4 Marks)
- (iv) An east to west orientation of a poultry house (4 Marks)
- (v) Administering a saline or sugar solution to chicks on arrival (4 Marks)

QUESTION TWO

- (a) A farmer intends to rear 2, 800 broilers. During the rearing period, its expected to loose 4.8% of the flock due to mortality. The birds are expected reach a body weight of 2840g from an initial weight of 42g. According to the management guide, consumption of different feed types should be as follows;

- Starter diet (0-21 days) 950g per chick
- Grower diets (22 – 28 days) 1200g per chick
- Finisher diet (29-42 days) 2300g per chick

Calculate the following;

- (i) Number of 50kg bags of Starter feed to be bought (3 Marks)
- (ii) Number of 50kg bags of grower feed to be bought (3 Marks)
- (iii) Number of 50kg bags of finisher feed to be bought (3 Marks)
- (iv) Using a stocking density of 12 birds/m², what would be the total area needed (3 Marks)

(b) Define each of the following terms used in poultry production;

- | | | |
|-------|-----------------------|-----------|
| (i) | Poultry farming | (2 Marks) |
| (ii) | Artificial Incubation | (2 Marks) |
| (iii) | Chick sexing | (2 Marks) |
| (iv) | Point of lay pullet | (2 Marks) |

SECTION B – PIG PRODUCTION

QUESTION THREE

A. Discuss five (05) factors one should consider before starting a pig enterprise
(10 Marks)

B. Give scientific reasons for the following

- | | | |
|------|---|-----------|
| i. | Why piglets are prone to hypothermia (chilling) | (2 Marks) |
| ii. | Why piglets are prone to iron deficiency anemia | (2 Marks) |
| iii. | Why pigs generally are prone to heat stroke | (2 Marks) |
| iv. | Why piglets at weaning are prone to diarrhea | (2 Marks) |
| v. | Why lysine is called a first limiting amino acid in pig nutrition | (2 Marks) |

QUESTION FOUR

A. Discuss five (05) general factors to consider when selecting female pigs for breeding?
(5 Marks)

B. Define feeding allowance and state the feeding allowance for the following classes of pigs

- | | | |
|------|---|-----------|
| i. | Lactating sow | (2 Marks) |
| ii. | Weaner pigs | (2 Marks) |
| iii. | Pregnant sow in all stages of pregnancy | (3 Marks) |
| iv. | Boar | (2 Marks) |

C. Differentiate the following terms

- | | | |
|------|--------------------------------|-----------|
| i. | Sow and gilt | (2 Marks) |
| ii. | Estrus period and estrus cycle | (2 Marks) |
| iii. | Litter size and litter number | (2 Marks) |

THE END



THE UNIVERSITY OF ZAMBIA
SCHOOL OF AGRICULTURAL SCIENCES
DEPARTMENT OF ANIMAL SCIENCE

2021/2022 FINAL EXAMINATIONS
AGA 4532 – PIG AND POULTRY PRODUCTION

INSTRUCTIONS TO CANDIDATES

Answer **any five questions** from the six provided

Use a separate answer booklet for each section

Read the questions carefully before attempting them

All questions carry equal Marks (20 Marks)

SECTION A – PIG PRODUCTION

QUESTION ONE

Write on the physical and production characteristics of any two breeds of pig reared in Zambia:
(20 marks)

QUESTION TWO

Aggressive behaviour is sometimes exhibited by pigs and has negative effects on the performance of the animals.

- (a) Write on any three situations where aggressive behaviour in pigs can occur.
(12 marks)
- (b) What measures can be taken to prevent the occurrence of the aggressive behaviour in the three situations you have written on (in 2a) above? (8 marks)

QUESTION THREE

Write briefly on any four of the following: (20 marks)

- (a) Preparing a farrowing pen for the birth of piglets.
- (b) Feeding piglets from day-old to 3 weeks of age
- (c) Advantages and disadvantages of castrating male pigs.
- (d) Any three (3) stages of life when pigs require to be weighed and why they have to be weighed at the mentioned stages.
- (e) Hand mating in pigs

SECTION B – POULTRY PRODUCTION

QUESTION FOUR

A farmer intends to rear 650 broiler chickens. S/He has been give the management guide table (attached to this question paper), to use as the guide in managing this strain of broilers. As the extension officer for the area, assist the farmer on the following;

- (i) The size (area) of the broiler house S/He is supposed to put up, if the maximum stocking density is 12 birds/m² (1 Marks)
- (ii) The length of the material needed to make the brooder ring;
 - (a) On the first day of placement (3 Marks)
 - (b) During the second week of brooding (3 Marks)
- (iii) Calculate the number of 50kg bags of each of the following types of feeds S/He will need to raise these birds based on the management guided attached;
 - (a) Starter feed (fed to chicks up to 21 days of age) (2 Marks)
 - (b) Grower feed (fed between 22nd and 28th day) (2 Marks)
 - (c) Finisher feed (fed from 29th day up to end of rearing cycle) (2 Marks)
- (iv) With three reasons, explain to the farmer the importance of giving chicks electrolytes during the first week of brooding (3 Marks)
- (v) Estimate the amount of skimmed milk (g) and water (litres) required for vaccinating the chicks against NCD at 10days of age (2 Marks)
- (vi) Calculate the cumulative feed conversion ratio of the flock, if it is assuming that the birds grew up to 2590g/bird as average live weight at 42 days of age, and their feed intake was exactly as indicated in the management guide (2 Marks)

QUESTION FIVE

A number of birds from a flock of Lohman brown layers, aged 16 weeks, were sampled and weighed. The weights of the sampled birds are shown in the table below.

- (i) Calculate the flock uniformity of this flock at this age. (5 Marks)

Weight of the birds (g)	No. of birds
1000	2
1050	3
1100	2
1150	4
1200	6
1250	8
1300	9
1350	11
1400	12
1450	9
1500	8
1550	7
1600	6
1650	4
1700	3
1750	2

- (ii) If at placement, there were 700 day old layer chicks, and the flock had a mortality rate of 4% during brooding and rearing up 16 weeks, how many birds were housed at point of lay? (2 Mark)
- (iii) With two reasons, explain why debeaking is preferred to be done to layers during their first week of their life (4 Marks)
- (iv) When in lay, the hen housed in (ii) laid 448, 490, 492, 511, 528, 534, and 547 eggs on Sunday, Monday, Tuesday, Wednesday, Thursday, Friday, and Saturday, respectively, calculate the weekly;
- (a) Hen day egg production % (4 Marks)
- (b) Hen housed egg production% (3 Marks)
- (v) Why should the farmer collect eggs from the pens more frequently in the morning than in the afternoon? (2 Marks)

QUESTION SIX

For fertile eggs to hatch, they have to be carefully selected and provided with the right incubation condition. Explain at least four factors that are considered when selecting hatching eggs for incubation (20 Marks)

AS HATCHED

Age Days	Weight for Age	Daily Gain (g)	Average Daily Gain (g)	Cumulative Feed Conversion	Daily Feed Consumption (g)	Cumulative Feed Consumption (g)
0	42					
1	52	10				
2	66	14				
3	81	15				
4	100	19				
5	122	22				
6	148	26				
7	177	29	25.3	0.847		150
8	208	31	26.0	0.865	30	180
9	242	34	26.9	0.888	35	215
10	279	37	27.9	0.914	40	255
11	320	41	29.1	0.938	45	300
12	364	44	30.3	0.962	50	350
13	410	46	31.5	0.988	55	405
14	459	49	32.8	1.013	60	465
15	511	52	34.1	1.039	66	531
16	567	56	35.4	1.063	72	603
17	626	59	36.8	1.088	78	681
18	688	62	38.2	1.112	84	765
19	753	65	39.6	1.135	90	855
20	821	68	41.1	1.158	96	951
21	891	70	42.4	1.182	102	1053
22	964	73	43.8	1.205	109	1162
23	1039	75	45.2	1.230	116	1278
24	1115	76	46.5	1.257	123	1401
25	1193	78	47.7	1.283	130	1531
26	1272	79	48.9	1.311	137	1668
27	1353	81	50.1	1.339	144	1812
28	1436	83	51.3	1.367	151	1963
29	1521	85	52.4	1.394	158	2121
30	1608	87	53.6	1.422	165	2286
31	1697	89	54.7	1.448	172	2458
32	1788	91	55.9	1.475	179	2637
33	1880	92	57.0	1.502	186	2823
34	1973	93	58.0	1.529	193	3016
35	2067	94	59.1	1.556	200	3216
36	2162	95	60.1	1.581	202	3418
37	2257	95	61.0	1.604	203	3621
38	2352	95	61.9	1.627	205	3826
39	2447	95	62.7	1.648	206	4032
40	2542	95	63.6	1.668	208	4240
41	2637	95	64.3	1.687	209	4449
42	2732	95	65.0	1.705	210	4659
43	2826	94	65.7	1.724	212	4871
44	2919	93	66.3	1.742	214	5085
45	3011	92	66.9	1.761	216	5301
46	3102	91	67.4	1.779	218	5519
47	3192	90	67.9	1.798	220	5739
48	3281	89	68.4	1.817	222	5961
49	3369	88	68.8	1.836	224	6185
50	3456	87	69.1	1.855	225	6410
51	3542	86	69.5	1.874	226	6636
52	3627	85	69.8	1.892	226	6862
53	3711	84	70.0	1.910	227	7089
54	3794	83	70.3	1.928	227	7316
55	3876	82	70.5	1.946	228	7544
56	3958	82	70.7	1.964	228	7772

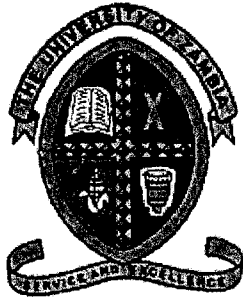

THE UNIVERSITY OF ZAMBIA
SCHOOL OF AGRICULTURAL SCIENCES
DEPARTMENT OF ANIMAL SCIENCE

END OF YEAR FINAL EXAMINATIONS 2014/2015

COURSE	: AGA 4552 ANIMAL PRODUCTS AND BY-PRODUCTS
DATE	: TUESDAY, 8 TH NOVEMBER 2022 09:00 HOURS
DURATION	: 3 HOURS
INSTRUCTIONS	: ANSWER FIVE QUESTIONS. EACH SECTION SHOULD BE WRITTEN IN A SEPARATE ANSWER BOOKLETS

SECTION A

1. People eat meat for various reasons which include tradition, nutritive value, availability, wholesomeness, variety, satiety value, and social or religions customs. Meat is also a highly pleasing food for many people, and the consumption of it is a measure of societal status world over but the ultimate eating quality of meat is dependent on the palatability and nutritive value. Write short notes on;
 - a) Palatability of meat
 - b) Juiciness of meat
 - c) Meat tenderness
 - d) Rigormortis (20 Marks)
2. Meat structure, Firmness and Texture are meat properties usually evaluated by consumers with visual (sight) or tactile (touch) senses. Explain briefly all the factors that influence meat structure, firmness and texture (20 Marks).
3. In the production of hides/skins, it easier to control the sources of defects and faults if one is knowledgeable on the causes. Defects and faults are caused at different stages of the animal's life, and these degrade the quality of hides/skins. Explain how defects and faults may occur and how one can minimise their occurrence;
 - a) During the animal's life
 - b) During slaughtering and flaying (20 Marks)

4. Curing refers to creation of unfavourable conditions and salt treatment is one method used to inhibit the action of harmful bacteria in order to prevent the damage and degenerative process bacteria can do to hides/skins. Write short notes on the Salt treatment of Hides/skins and explain the significance of each salting method to production of quality hides/skins **(20 Marks)**.

SECTION B

ANSWER ALL QUESTIONS

Q1. Several dairy companies have put some fairly widely consumed processed products on the Zambian market. For any product of your choice found on the Zambian market outline the practices, procedures, tests and processes that the milk is subjected to from milking to packaging as a safe and quality product ready for the market. **20 marks**

Q2. Size, shape, and colour are physical characteristics that are among the standards used when grading eggs according to quality. These characteristics also affect consumer acceptance of the eggs. Write briefly on the following:

- i. Any six (6) factors that affect the size of eggs produced by a hen.
- ii. Any three (3) factors associated with egg shape variation.
- iii. One factor that affects the colour of eggs produced.

END OF EXAMINATION

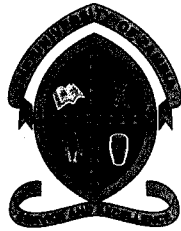

THE UNIVERSITY OF ZAMBIA
UNIVERSITY DEFERRED/SUPPLEMENTARY EXAMINATIONS – FEBRUARY 2021

AGA 5121 – Advances in Animal Nutrition

Time allowed: Two (2) Hours

Marks: 60

INSTRUCTIONS TO CANDIDATES:

- a. Answer any **three (3)** questions, **at least one from each section.**
b. All Questions carry equal marks (20).
-

SECTION A (RUMINANT NUTRITION):

- Q. 1** The current Farm Manager at the Liempe University Farm would like to compound a feedlot ration for 304 beef steers by making use of on-farm readily available feed ingredients in order to reduce the costs of production. The feed ingredients the Farm Manager would like to use were analyzed in the Department of Animal Science Laboratory. Formulate a dry season feedlot ration for the 304 beef steers by using the Double Pearson Square method. The feedlot ration must contain 14.0% DCP and 70% TDN and must include 10% Rhodes Grass and Silver-leaf Hay mixture, 8% Soyabean Straw, 5% Maize Bran, 2% Sugarcane Molasses, 2% Di-calcium Phosphate, 2% Mineral Premix and 1% Salt, on dry matter basis.

FEED	DM%	DCP%	TDN%	Ca	P
Rhodes/Silver Leaf Hay	92	22.5	58	1.90	0.20
Maize Bran	90	12.5	70	0.07	1.62
Molasses	75	-	85	1.19	0.11
Soyabean Straw	88	25.0	65	0.69	0.06
Di-Calcium Phosphate	-	-	-	26.0	18.00
Limestone Flour	-	-	-	38.0	0.04
Salt	-	-	-	-	-

The analyses of other available feed ingredients at the farm are:

FEED	DM%	DCP%	TDN%	Ca	P
Maize Meal	89	10.0	88	0.03	0.31
Groundnut Meal	95	43.0	90	0.18	3.62
Groundnut Haulms	87	12.0	62	0.07	0.17
Lucerne Hay	90	15.0	60	0.27	0.03

(20 marks)

- Q. 2** a. How much concentrate mixture consisting of 40% Maize Meal, 30% Cottonseed Cake, 20% Cassava Meal and 10% Cane Molasses should be fed to provide sufficient energy to maintain a 520 kg empty Friesian cow that is losing 0.5 kg body weight per day two weeks post-partum yet the cow consumes 25 kg/day

maize silage and produces 25 kg/day milk containing 3.8% butterfat (BF) and 8.6% solids-not-fat (SNF) per kg?

The following may be used to answer the question:

	DM (g/kg)	ME (MJ/kg DM)
Maize silages	300	9.0
Maize Meal	870	12.5
Cane Molasses	770	14.0
Cottonseed cake	920	12.5
Cassava meal	870	11.0

(10 marks)

- b. Calculate the expected peak milk yield of the cow in Q. 2 a. above.
(1 mark)
- c. If the Friesian cow in Q. 2 a. above was actually in mid-lactation with no live-weight change in her body weight, how much concentrate mixture should she be fed?
(3 marks)
- d. If the Friesian cow in Q. 2 a. above was actually in late lactation and was gaining 0.5 kg per day, how much concentrate mixture should she be fed?
(3 marks)
- e. Using the Rapid Formulation Method, calculate the forage and concentrate dry matter intake of the Friesian cow in Q. 2 a. above?

(3 marks)

Q. 3 Write notes on the following:

- a. The functions of micro-organisms in the ruminant stomach; and
(10 marks)
- b. Causes of hypocalcaemia, treatment and the methods of prevention in dairy cattle.

(10 marks)

SECTION B (NON-RUMINANT NUTRITION):

- Q. 4** a. Explain the steps needed to take in order to select feed ingredients for use in formulating diets for animals on a farm?
(10 marks)
- b. Briefly, explain the different methods used in formulating animal rations and what are the advantages and disadvantages of each method?
(10 marks)

Q. 5 a. Explain why we need to monitor feed intake in farm animals and what steps do you need to follow to ensure you accurately measure feed consumption in farm animals?

(10 marks)

b. What is feed conversion efficiency and what steps do you need to undertake in order for you to accurately calculate feed conversion efficiency in farm animals?

(10 marks)

Q. 6 a. What are trypsin inhibitors and what steps do you need to undertake in order to minimize their anti-nutritional effects when feeding grain legumes to non-ruminants?

(10 marks)

b. Why do we need to process feed before giving it to animals and what are the main feed processing methods used in the animal industry?

(10 marks)

End of Examination

The following may be used to answer the questions:

i. $MI = \frac{EVI \times 1.05}{0.62}$

ii. $Kg = 0.0435 M/D$

iii. $MEP = MER - Mm$

iv. $Mm = 8.3 + 0.091 W$

v. $FD = \frac{DMI (MC - M/D)}{(MC - MF)}$

vi. $DMI = 0.025 W + 0.1 Y$

vii. $Eg = \frac{MEP \times 0.0435 M/D}{1.05}$

viii. $Eg = MEP \times 0.0414 M/D$

ix. $DMI = 0.025 W + 0.1 Y - 2.5$

x. $LWG = \frac{Eg}{6.28 + 0.3 Eg + 0.0188 W}$

xi. $KI = \frac{0.0435 M/D}{1.05}$ or $0.0414 M/D$

xii. $EVI = 0.0386 BF + 0.0205 SNF - 0.236$

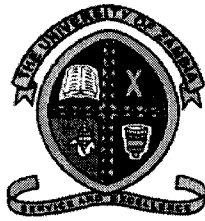

THE UNIVERSITY OF ZAMBIA
SCHOOL OF AGRICULTURAL SCIENCES
DEPARTMENT OF ANIMAL SCIENCE

AGA 5321: APPLIED ANIMAL REPRODUCTION
SUPPLEMENTARY EXAMINATION - FEBRUARY 2022

INSTRUCTIONS:

- ANSWER EACH SECTION IN A SEPARATE ANSWER BOOKLET
- ANSWER QUESTION ONE AND ANY OTHER TWO QUESTIONS
- CLEARLY WRITE THE NUMBER OF EACH ATTEMPTED QUESTION
- START EACH QUESTION ON A NEW PAGE
- ALL QUESTIONS CARRY EQUAL MARKS (20 MARKS).

SECTION A

QUESTION ONE

Write short notes on the following terms as they are used in animal reproduction;

- (a) Luteolysis (2 Marks)
- (b) MRP (2 Marks)
- (c) Pampiniform plexus (2 Marks)
- (d) Capacitation (2 Marks)
- (e) Sertoli cells (2 Marks)

With regard to farm animals;

- (a) Explain two indirect methods of pregnancy diagnosis in livestock (4 Marks)
- (b) Describe the two-cell two-gonadotropin theory in the female (2 Marks)
- (c) Briefly explain what a transgenic animal is (2 Marks)
- (d) Describe two (2) semen related causes of infertility (2 Marks)

QUESTION TWO

- (a) Briefly explain two methods used in oestrus synchronization. (4 Marks)
- (b) Briefly explain one factor involved in maternal recognition of pregnancy (2 Marks)
- (c) Draw and clearly label the main features of a follicle (6 Marks)
- (d) Briefly explain two (2) features involved in thermoregulation in testes (4 Marks)
- (e) How would you diagnose and treat a cow that has an ovarian cyst (4 Marks)

SECTION B

QUESTION THREE

With regard to farm animals;

- (a) Discuss the sites for semen deposition during natural mating in farm animals **(5 Marks)**
- (b) Briefly explain the benefits of artificial insemination use in animal production **(6 Marks)**
- (c) With reference to a cow, briefly discuss the basis for your prediction of appropriate breeding time. **(4 Marks)**
- (d) If you were a training officer on AI, briefly explain what sign of oestrus is critical to your determination of the breeding time. **(2 Marks)**
- (e) Differentiate between artificial and natural insemination **(3 Marks)**

QUESTION FOUR

- (a) Explain why and when use of imported semen would be disadvantageous to farmers **(4 Marks)**
- (b) Suggest potential approaches needed to increase its adoption rate among the Zambian pig farmers. **(4 Marks)**
- (c) What is and when would you use timed AI? **(2 Marks)**
- (d) Discuss the aids you would use in order to improve oestrus detection in cattle. **(6 Marks)**
- (e) Discuss the constraints to wide-spread artificial insemination application among pig farmers in Zambia **(4 Marks)**

GOOD LUCK

BONNE CHANCE

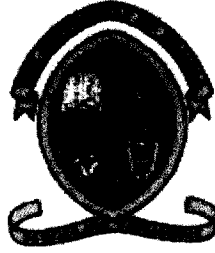

**THE UNIVERSITY OF ZAMBIA
UNIVERSITY DEFERRED EXAMINATIONS – FEBRUARY 2022**

**AGA 5562
INTEGRATED AQUACULTURE AND FISH NUTRITION**

DURATION: 2 HOURS

DATE: 18/02/2022

INSTRUCTIONS:

- 1) There are two sections in this paper, Section A and Section B.
- 2) Section A has ONE (1) question. This question is **COMPULSORY**.
- 3) Section B has three (3) questions, **answer any TWO (2) questions in this section.**
- 4) Start answering each question on a separate page.
- 5) Make sure to write your computer number on each page of your answer sheet.

SECTION A (Answer all questions)

1. Explain the following terms as applied in Integrated Aquaculture and Fish Nutrition: [20 marks in total]
- a. Secchi disk [2 marks]
 - b. Processed feeds [2 marks]
 - c. BOD [2 marks]
 - d. RGL [2 marks]
 - e. *Nitrobacter* sp. [2 marks]
 - f. Alkalinity [2 marks]
 - g. Fish ranching [2 marks]
 - h. RAS [2 marks]
 - i. Composting [2 marks]
 - j. High-rate ponds [2 marks]

SECTION B (Choose any two (2) questions)

1. Answer the following questions: [20 marks in total]
- a. Give any eight (8) characteristics of Intensive Aquaculture Production Systems. (8 marks)
 - b. Discuss in detail the four (4) components of a recirculating aquaculture system. (12 marks)
2. Small holder farmers in Zambia can easily integrate fish farming with other agricultural enterprises on their farms. Answer the following questions: [20 marks in total]
- a. What are the two main goals of practicing Integrated Agriculture-Aquaculture. (4 marks)
 - b. Discuss the design and management of Fish/Crops Structures. (10 marks)
 - c. Give six advantages of integrated Agriculture-Aquaculture systems (6 marks)

3. Answer the following questions. [20 marks in total]

- a. In details, discuss how fish farmers should go about handling and storage of fish feeds. (18 marks)
- b. What is involved in the chemical evaluation of fish feeds? (2 marks)

**END OF EXAMINATION
GOOD LUCK!**



**THE UNIVERSITY OF ZAMBIA
UNIVERSITY EXAMINATIONS – NOVEMBER 2022**

**AGA 5562
INTEGRATED AQUACULTURE AND FISH NUTRITION**

DURATION: 3 HOURS

DATE: 11/11/2022

INSTRUCTIONS:

- 1) There are two sections in this paper, Section A and Section B.
- 2) Section A has TWO (2) questions. These questions are **COMPULSORY**.
- 3) Section B has four (4) questions, **answer any THREE (3) questions in this section.**
- 4) Start answering each question on a separate page.
- 5) Make sure to write your computer number on each page of your answer sheet.

SECTION A (Answer all questions)

1. Explain the following terms as applied in the course Integrated Aquaculture and Fish Nutrition: **[20 marks in total]**
- a. Biofilter [2 marks]
 - b. Planktons [2 marks]
 - c. BOD [2 marks]
 - d. Sustainable Aquaculture [2 marks]
 - e. *Nitrobacter* sp. [2 marks]
 - f. Alkalinity [2 marks]
 - g. Fish ranching [2 marks]
 - h. Recirculating Aquaculture System [2 marks]
 - i. Composting [2 marks]
 - j. High-rate ponds [2 marks]
2. Answer the following questions: **[20 marks in total]**
- a. The nutritional requirements of fish vary among species and also within species. Discuss the principle behind this statement. (5 marks)
 - b. Give two (2) important examples of phytoplanktons and three (3) of zooplanktons. (5 marks)
 - c. Least cost feed formulation can be achieved by use of computers through linear programming software. What information needs to be provided to run the software? (4 marks)
 - d. In formulating fish diets, special ingredients may be added to serve different purposes. Give six (6) examples of the different purposes for adding special ingredients in fish diets. (6 marks)

SECTION B (Choose any three (3) questions)

3. Answer the following questions: **[20 marks in total]**
- a. Give any eight (8) characteristics of Intensive Aquaculture Production Systems. (8 marks)
 - b. Discuss in detail the four (4) components of a recirculating aquaculture system. (12 marks)

4. Small holder farmers in Zambia can easily integrate fish farming with other agricultural enterprises on their farms. Answer the following questions: **[20 marks in total]**
- As an Animal Scientist equipped with aquacultural expertise, discuss the design and characteristics of integrated fish/crop farming that can be used on the farm. (12 marks)
 - Explain four (4) positive interactions of agriculture-aquaculture systems. (4 marks)
 - What are some of the issues to consider when choosing the type of livestock to rear under a Fish/Livestock integrated farming system? (4 marks)
5. The demand for aquatic food products has been projected to rise. In order to meet this growing demand, Sustainable Aquaculture Production will have to be embraced by any well-meaning farmer. **[20 marks in total]**
- What is Sustainable Aquaculture Production? (3 marks)
 - How can Sustainable Aquaculture Production be achieved? (6 marks)
 - Composting is one way of reclaiming valuable nutrients from organic waste. Give advantages and drawbacks of composting. (6 marks)
 - Besides the benefits in wastewater treatment gained from waste-grown algae, it can be further used for other purposes. Mention four (4) other ways in which waste grown algae may be utilised. (5 marks)
6. Answer the following questions. **[20 marks in total]**
- In details, discuss how fish farmers should go about handling and storage of fish feeds. (18 marks)
 - What is involved in the chemical evaluation of fish feeds? (2 marks)
-

**END OF EXAMINATION
GOOD LUCK!**

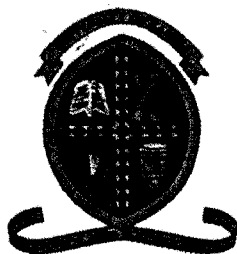

UNIVERSITY OF ZAMBIA
SCHOOL OF AGRICULTURAL SCIENCES
DEPARTMENT OF ANIMAL SCIENCE

AGA 5712- ANIMAL HEALTH FINAL EXAMINATION

DATE: 01/11/2022

INSTRUCTIONS:

1. Answer **ALL** questions
 2. Use a **separate answer booklet** for each question
 3. Duration: 3 hours
 4. Total marks **100**
-

QUESTION 1

For each of the tick species listed below, describe their life cycle, preferred hosts and pre-direction sites for the adult stage and their economic importance.

- | | |
|--|-----------|
| A. <i>Rhipicephalus appendiculatus</i> | (5 marks) |
| B. <i>Amblyomma variegatum</i> | (5 marks) |
| C. <i>Rhipicephalus microplus</i> | (5 marks) |
| D. <i>Hyalomma truncatum</i> | (5 marks) |

QUESTION 2

- A. Outline the life-cycle of the pork tapeworm (*Taenia solium*) (10 marks)
- B. State five (5) ways of preventing infections of *Taenia solium* in the definitive host. (10 marks)

QUESTION 3

Write short notes on Theileriosis under the following subtopics:

- A. Etiology (2 marks)
- B. Transmission (4 marks)
- C. Clinical signs (4 marks)
- D. Laboratory diagnosis (6 marks)
- E. Control (4 marks)

QUESTION 4

You are visiting your friend in Chilanga who has recently established a feedlot. He explains to you that some of his cattle he brought in from Mazabuka are showing signs of illness. You examine the affected animals and find that they have fever, a weak protective cough, mucopurulent nasal discharge, anorexia, toxæmia and abnormal lung sounds.

- A. What is the tentative diagnosis? (2 Marks)
- B. List three (3) differential diagnoses for this condition. (6 Marks)
- C. What is the best way to confirm the diagnosis indicated in (a) above? (4 Marks)
- D. How is this condition best controlled? (8 Marks)

QUESTION 5

- A. State two general ways in which an animal can acquire immunity against diseases (2 marks)
- B. List five (05) differences between innate immunity and acquired immunity (5 marks)
- C. Farm animal infections can present as either acute or chronic forms. Differentiate acute infection and chronic infection and give one example of an infection that falls in each category. (6 marks)
- D. What are the six (06) general sources of infections (3 marks)
- E. Briefly explain any four (04) modes (routes) of disease transmission (4 marks)

THE END

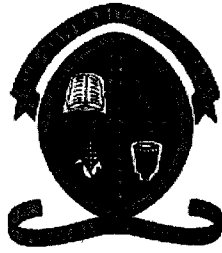

The University of Zambia
School of Agricultural Sciences
Department of Animal Science

2021/2022 FINAL EXAMINATIONS

AGA 6132: Vitamins and minerals Metabolism

Date: 14th November 2022

Time: 09:00 Hours

=====

Instructions: Answer any five (5) questions, they all carry 20 equal Marks.

Question One

- A). What are the sources and metabolic functions of Vitamin A and how are some of these functions related with those of Zinc **(12 Marks)?**
- B). Explain the importance of electrolytes in animal metabolism and how are these elements supplied in animal diets **(8 Marks)?**

Question Two

- A). Vitamin K and Biotin tend to induce their metabolic functions through carboxylation reactions, explain the key differences in carboxylation mechanisms of biotin from that of Vitamin K **(14 Marks)?**
- B). Name the different forms of Vitamin K available to farm animals and what are the main sources for each type and how it contributes to meeting animal nutritional requirements for vitamin K **(6 Marks)?**

Question Three

A). Explain the importance of Vitamin E in animal nutrition and how do animals meet requirements for this vitamin **(10 Marks)?**

What is the relationship in the metabolic functions of vitamin E and selenium and why is selenium said to have a sparing effect in meeting requirements for Vitamin E **(4 marks)?**

B). What are the deficiency symptoms of Choline and how do animals meet requirements for this vitamin **(6 Marks)?**

Question Four

A). What are the main factors regulating Iron absorption in farm animals and what are the main storage forms for this mineral element in animal tissues **(12 Marks)?**

B). What is iron overload and how is this condition brought about in both humans and farm animals **(8 Marks)?**

Question Five

A). Poisoning with heavy metals is mostly associated with industry pollution or careless handling of chemicals on farms. Explain the dangers of lead and mercury poisoning and how such dangers can be avoided or minimized on farms **(8 Marks)?**

B). Explain the importance of calcium and phosphorus in animal nutrition and how the metabolism of these mineral elements is related with that of vitamin D3 **(12 Marks)?**

Question Six

A). Explain the steps involved in the digestion and subsequent absorption of Vitamin B12 what are some of the factors that may lead to Vitamin B12 deficiency symptoms in farm animals despite adequate dietary supplies in animal foods **(10 Marks)?**

B). What is the importance of cobalt in farm animals and how does the animal meet its dietary requirements **(6 Marks)?**

C). Why is it that the deficiency of copper and Iron both may result in anemia **(4 Marks)?**

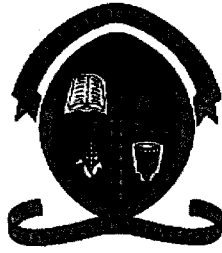

UNIVERSITY OF ZAMBIA
SCHOOL OF AGRICULTURAL SCIENCES
DEPARTMENT OF ANIMAL SCIENCE

AGA 6142: Proteins and Amino Acids Metabolism

Date: 21st November 2022

Time: 14:00 Hours

=====

Instructions: Answer any Five (5) questions, they all carry 20 equal Marks.

Question One

A). Explain the digestion of proteins in different segments of the non-ruminant gastro-intestinal tract detailing the enzymes involved and the hydrolysis products generated including how the end products of protein digestion are utilized by the host animal **(12 Marks)?**

B). What are synthetic amino acids and what are the advantages and disadvantages of using synthetic amino acids in animal nutrition **(8 Marks)?**

Question Two

A). Giving at least two different examples for each; explain what rare amino acids are and how they can be differentiated from non-protein amino acids? What are some of the similarities between rare and non-protein amino acids?

B). Explain at least two examples of the reactions of amino acids that take place on the amino group of amino acids and what is the importance of such reactions as far as quantification and identification of amino residues are concerned?

Question Three

- A). With the help of a diagram, explain the steps involved in the degradation of amino acids Threonine, Glycine and Serine into acetyl CoA via Pyruvate and the role of tetra hydro folate in single carbon transfer metabolic reactions **(12 Marks)?**
- B). Explain the steps for biosynthesis of serine from 3-phosphoglycerate and how the biosynthesis of this amino acid is linked with that of glycine and threonine **(8 Marks)?**

Question Four

- A). Explain the steps involved in the degradation of proline to α -ketoglutarate and how is the degradation of this amino acid related to that of Arginine **(10 Marks)?**
- B). Explain the steps that are required in the biosynthesis of Leucine and Valine using pyruvic acid as the starting metabolite and how is the biosynthesis of isoleucine associated with that of threonine **(10 Marks)?**

Question Five

- A). Explain the steps you may have to consider when evaluating the quality of proteins for a given animal species **(12 Marks)?**
- B). What is amino acid imbalance and how do such imbalances affect utilization of different nutrients in non-ruminants **(8 Marks)?**

Question Six

- A). Explain the steps you may have to follow in quantifying different amino acids in a given feedstuff and what type of precautions you may wish to consider for you to have reliable results **(12 Marks)?**
- B). Explain the importance of acid-base properties of different amino acids and how these properties are utilized in the separation of different amino acids **(8 Marks)?**



THE UNIVERSITY OF ZAMBIA

**SCHOOL OF AGRICULTURAL SCIENCES
DEPARTMENT OF PLANT SCIENCE**

**SECOND YEAR EXAMINATION FOR BACHELOR OF AGRICULTURAL SCIENCES
AGC 2110: FUNDAMENTALS OF PLANT SCIENCE
FINAL EXAMINATION 2021 /2022**

DATE: 3RD NOVEMBER, 2022

TIME: 14:00 -17:00 HRS

VENUE: DRGS

Instructions:

- 1. Answer all questions.**
- 2. Marks are as indicated.**

Question 1

What is vernalization? **(2 Marks)**

In determining Reference Evapotranspiration, what do the terms R_a , R_n and R_x refer to? **(2 Marks)**

Briefly describe the method that provides a measurement of the integrated effect of radiation, wind, temperature and humidity from an open water surface. **(2 Marks)**

What are the abiotic factors affecting photosynthesis? **(2 Marks)**

How would do you go about and obtain materials to grow your own food if you were a space traveller to Mars, a journey which takes about 9 months? **(2 Marks)**

Question 2

Given the Reference (ET_o) and crop (ET_{crop}) Evapotranspiration of crops 1 and 2:

Crop 1	Crop 2
$ET_o = 14 \text{ mm}$	$ET_o = 14 \text{ mm}$
$ET_{crop} = 6 \text{ mm}$	$ET_{crop} = 13 \text{ mm}$

From the calculation of the Crop coefficients, which was the stage of development of each of the two (2) crops. **(5 Marks)**

Question 3

- i) What is Photosynthetic Active Radiation? (4 Marks)
- ii) Two (2) Sorghum varieties Sima and Lusitu Local were planted at the Field Station of the University of Zambia in late November, 2018. Plants from the Sima variety had started flowering by Mid-March 2019. All the plants from the Lusitu local variety only flowered in June 2019.
- Explain the underlying phenomenon. (6 Marks)

Question 4

You partly participated in the performance of Wheat varieties Shungu and Lorrie under selected Nitrogen Fertilizer and Irrigation levels. The soil moisture conditions and the plant parameters measured are given in Table 1.

Table 1: Nitrogen and Irrigation levels applied and parameters measured on Wheat varieties

WHEAT VARIETY	IRRIGATION (MM)	NITROGEN	PRODUCTIVE TILLERS	YIELD (T/HA)	EFFECTIVE ROOTING DEPTH (CM)
Shungu	500	120	98	9.1	49.5
Shungu	350	210	94	8.1	52.5
Shungu	500	300	125	10.6	51.0
Lorrie	500	120	66	6.9	39.6
Lorrie	350	210	63	6.0	42.0
Lorrie	500	300	84	8.0	40.8

Determine the Wheat variety, which should be grown by farmers under adverse nitrogen and water conditions. (15 Marks)

Question 5

Choose two (2) crops from each group in Table 2.

Table 2: Group and type of crop

GROUP	CROP
1	Maize
	Sorghum
	Wheat
2	Cowpea
	Common bean
	Soybean

i) For each selected crop, give the scientific name and the centre of origin. (3 Marks)

ii) Briefly describe the morphological features for the selected crops in each group? (3 Marks)

iii) What are three of their economic importance for the selected crops in each group? (4 Marks)

Question 6

- i) What is "Totipotency" and its importance in Tissue Culture. (5 Marks)
- ii) Suggest how you could use Tissue culture to make Cassava planting materials free of viruses and quickly have the planting materials available to farmers. Draw from your experience on the visit to Mt. Makulu Central Research Station. (5 Marks)

Question 7

- i) How are plant nutrients created? (3 Marks)
- ii) How was Hydroponics effectively utilized in the study you carried out to determine the functions of plant nutrients in plant growth and development? (3 Marks)
- iii) Describe the functions of Calcium (Ca) and Boron (B) in plant growth and development. (4 Marks)

Question 8

- i) What are mineral and non-mineral elements in plants and what are the sources of these nutrients? (4 Marks)
- ii) Fertilizer "D" Compound produced by Nitrogen Company of Zambia (NCZ) is suitable for application in crop production. The nutrient content of the 2 fertilizers is shown in Table 3.

Table 3: Nutrient content of fertilizers

FERTILIZER	ORIGIN	N		P ₂ O ₅		K ₂ O	
		Reg	Anal	Reg	Anal	Reg	Anal
Compound D	NCZ	10	10.68	20	19.7	10	10
Tolerance			6.8%		1.5%		0.0%
Wheat blend	Origen	12	21.65**	20	14.32**	40	14.6**

Reg. – Registered (Nutrient contend shown on the bag of fertilizer)
 Anal. – Analyzed (Average Nutrient content analyzed at Laboratories at Soil laboratory in the School of Agricultural Sciences at University of Zambia and at Mt. Makulu Laboratory)

There are however challenges in application of the fertilizer Compound "Wheat blend" for crop production. Discuss possible problems associated with this fertilizer in crop production. (6 Marks)

Question 9

- i) Define Agroforestry. (5 Marks)
- ii) Given the total nitrogen (NH_4 and NO_3) of the agroforestry species given in Figure 1., explain which agroforestry species you can use for top dressing of N in Maize production. (5 Marks)

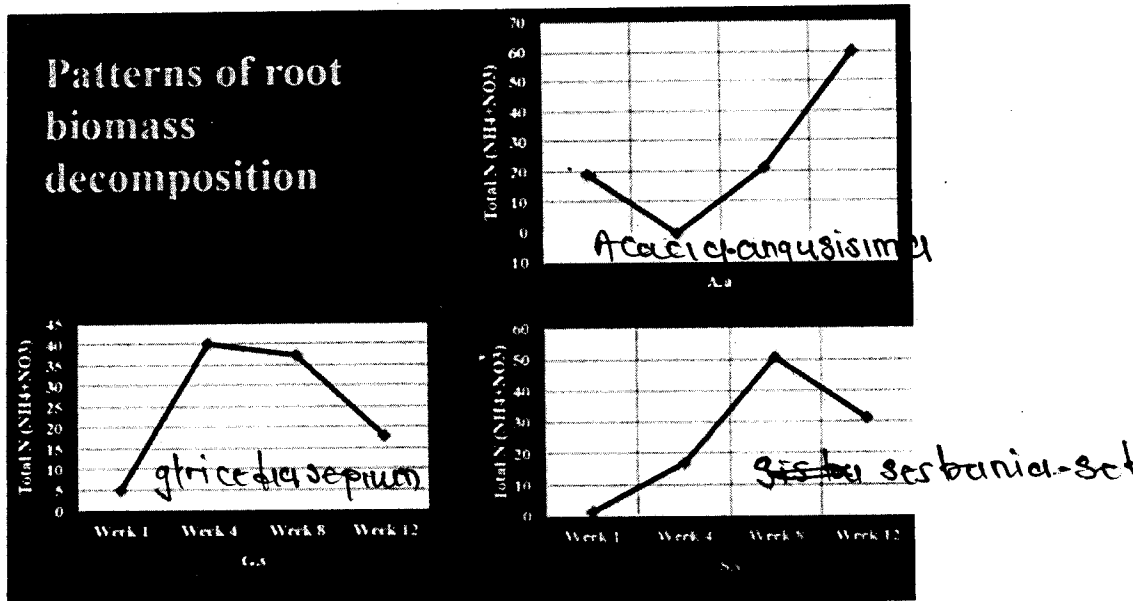

Figure 1: Patterns of root biomass decomposition of given

Question 10

- i) Which are the three (3) phytohormones involved in the processes of germination and senescence in plants? (4 Marks)
- ii) Explain how these phytohormones in conjunction with external factors regulate these growth processes. (6 Marks)

End of Examination



The University of Zambia

**School of Agricultural Sciences
Department of Plant Science**

**Third Year Examination for Bachelor of Agricultural Sciences
AGC 3135: FUNDAMENTALS OF PLANT SCIENCE
Final Examination 2021/2022**

Date: 22nd June, 2022

Time: 09:00 –12:00 HRS

Venue: Omnia 1

Instructions:

- 1. Answer all Questions**
- 2. Marks as indicated**

Question 1 (15 Marks)

- a) Why is the toxic effect of Aluminium in acidic soils greater at higher (4.5) pH than at a lower (4.0) pH? **(3 Marks)**
- b) List four methods for determining Reference Evapotranspiration. **(3 Marks)**
- c) Briefly describe the two most comprehensive methods for determining Reference Evapotranspiration and explain why they are comprehensive. **(3 Marks)**
- d) Explain using soil water potential why plants grow differently in soils with same water content. **(3 Marks)**
- e) Briefly describe the process of Photosynthesis. **(3 Marks)**

Question 2 (20 Marks)

- i) Describe three constraints faced by commercial and small-scale farmers in the environmental area. Briefly explain how these constraints can be overcome? **(10 Marks)**
- ii) How can constraints related to food nutrition be overcome by farmers and rural population? **(10 Marks)**

Question 3 (25 Marks)

- i) How are plant nutrients required for plant growth categorized? **(2 Marks)**
- ii) Briefly describe the functions of the following Plant nutrients in plant growth: **(8 Marks)**
 - a) Calcium,
 - b) Magnesium,
 - c) Boron, and
 - d) Molybdenum
- iii) A comparative study on Cowpea in Hydroponic solution system was carried out where all the essential plant nutrients were applied compared to the treatment where P was missing.

Explain the results of Chlorophyll and Stem biomass obtained in the two treatments. Results are given in Table 1. (15 Marks)

Table 1: Cowpea parameters measured

CROP	TREATMENT	CHL	STBMS	S.E
Cowpea	Control	200.38	261.02	1.63
Cowpea	Missing P	238.50	122.00	2.00

Key:

CHL - Chlorophyll content index

P - Phosphorus

STBMS - Stem biomass

S.E. - Standard Error

Question 4 (20 Marks)

- i) Briefly describe the different Hydroponics methods. (5 Marks)
- ii) How was the Hydroponics method practiced at York Farm which you visited different from the typical Hydroponics method of the similar type. (5 Marks)
- iii) How were crop growth factors optimized for Rose and Tomato production with the Hydroponics system implemented at York Farm? (5 Marks)
- iv) How are crop growth factors optimized in small-holder crop production? (5 Marks)

Question 5 (20 Marks)

Explain how external and endogenous (phytohormones) factors affect the plant Embryonic Phase.

END OF EXAM

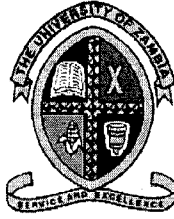

The University of Zambia

School of Agricultural Sciences
Department of Plant Science

Third Year Examination for Bachelor of Agricultural Sciences
AGC 3135: FUNDAMENTALS OF PLANT SCIENCE
Supplementary Examination 2022

Date: Wednesday 16th February, 2022

Time: 09:00 –10: 000 HRS

Venue: Omnia 1

Instructions:

1. Answer all questions
2. Marks as indicated

Question 1 (20 Marks)

Given the minimum, optimum and maximum temperature for germination of the crops listed in Table 1, what is the appropriate time of the year to grow these crops. Give reasons for your answer.

Table 1: Temperatures for crop germination

CROP	TEMPERATURE		
	Min T°C	Opt T°C	Max T°C
Wheat	4	29	42
Maize	10	34	46
Sunflower	5	35	47
Pumpkin	11	34	46
Sorghum	12	36	48

Question 2 (20 Marks)

- i) Describe the constraints faced by small and large-scale farmers in the environmental area (10 Marks).
- ii) How can the constraints be overcome? (10 Marks)

Question 3 (40 Marks)

- i) Describe the experiment you implemented on wheat production on measurement of soil water content using the Neutron moisture probe. **(5 Marks)**
- ii) Explain the underlying principles for soil water determination. **(10 Marks)**
- iii) Explain the wheat crop performance with good growth (GGR) and poor growth (PGR) with respect to the grain yield, plant height of the wheat crop, soil moisture storage values and the effective root depth. Suggest recommendations for wheat crop production under irrigation. **(25 Marks)**

Table 1: Parameters measured

PERFORMANCE	PLTHGT (cm)	GRYLD (ton/ha)	S cm ³	EFRD (cm)
GGR	73.2	8.3	20.7	69.4
PGR	64.0	4.2	16.6	72.2

Key:
PLTHGT - Plant height
GRYLD - Grain yield
S - Soil water storage
EFRD - Effective root depth

Question 4 (20 Marks)

- i) What is plant tissue culture? **(5 Marks)**
- ii) What is Totipotency? **(5 Marks)**.
- iii) Explain why Tissue Culture is important in crop improvement and development. **(10 Marks)**

END OF EXAM



THE UNIVERSITY OF ZAMBIA
UNIVERSITY FINAL EXAMINATIONS – NOVEMBER 2022

AGC 3412 - INTRODUCTORY HORTICULTURE

TIME: Three (3) hours

MARKS:100

INSTRUCTIONS: Answer all questions.
Marks are as indicated.

Question 1

- a. When some crops inhibit the growth of other plants, what is this referred to as?
2 marks
- b. What do the crops in 1a. produce?
2 marks
- c. From the answer in 1b., at what stage during growth of plants are these crops produced?
2 marks
- d. In potholing, basins are made at _____ between rows and _____ within rows.
2 marks
- e. When ripping, the furrows are made at _____ between rows at a depth of _____.
2 marks
- f. Discuss the role hedge rows play in organic vegetable production.
10 marks

Question 2

- a. Define the term "Senescence".
2 marks
- b. What is farm yard manure (FYM)?
3 marks
- c. What is the main advantage of using FYM?
2 marks
- d. List the factors that determine the composition of FYM.
5 marks
- e. Herbs and spices are used for various purposes. Outline the uses giving one (1) relevant example for each of the named purposes.
8 marks

Question 3

- a. List the goals of harvesting horticultural products. **4 marks**
- b. A group of youths engaged in Tomato production are about to harvest their crop. As a Horticultural expert, discuss and give guidance on how they should harvest the crop. **15 marks**
- c. Fill in the following table: **8 marks**

CROP	SCIENTIFIC NAME
Cabbage	
Onion	
Tomato	

Question 4

- a. Name the main factor that determines the postharvest life of horticultural commodities. **2 marks**
- b. Briefly explain why crop residues should be maintained on a farm. **6 marks**
- c. Composting of farm residues is important in sustainable agriculture. As a University of Zambia graduate in the School of Agricultural Sciences, you are hired to conduct a practical training for a group of farmers in compost making. Describe a step by step procedure on how to make a compost heap. **10 marks**

Question 5

Disciplinary areas of Horticulture are vast.

- d. Mention a discipline of Horticulture that you practised as a student of AGC 3412 at the field station. **2 marks**
- e. Give one (1) distinguishing feature of determinate and indeterminate varieties of Tomatoes. **1 mark**

As in 5b. above, give an example of the following:

- i. Determinate variety. **2 marks**
- ii. Indeterminate variety. **2 marks**
- f. In Onion production, spacing should relate to field operations and required bulb size.
 - i. Briefly describe the relationship between spacing and field operations. **5 marks**
 - ii. Briefly describe the relationship between spacing and required bulb size. **5 marks**



UNIVERSITY OF ZAMBIA
School of Agricultural Sciences
Department of Plant Science

Fourth Year Examinations for Bachelor of Agricultural Sciences
AGC 4320: Principles and Application of Entomology
2021/2022 Final Examination

Date: 31st October, 2022

Time: 14-17hrs

Venue: Other Rooms

INSTRUCTIONS:

- 1. There are two sections: Principles of Entomology and Applications of Entomology**
 - 2. Answer ALL 3 questions in Section 1 and 2 questions in Section 2**
 - 3. Use separate answer books for each section**
-

SECTION 1: Principles of Entomology

QUESTION 1 (20 MARKS)

- a. You have been asked to advise students in correct way of writing insect species scientific names. One student wrote the name of an insect species as *spodoptera Frugiperda* (J. E. Smith)
- (i) What is the common name for this insect species? **(1 mark)**
 - (ii) Mention the rule(s) of writing scientific names that has been violated **(4 marks)**
 - (iii) What is the correct scientific name? **(1 mark)**
 - (iv) What is the genus name for this insect species? **(1 mark)**
 - (v) Who is the first scientist to describe the insect species? **(1 mark)**
 - (vi) Name the Phylum, Class, Order and Family of this insect species. **(4 Marks)**
- b. As an extension officer, you come across a new pest, describe the various methods that you can use to identify the pest. **(6 marks)**
- c. Define binomial nomenclature. **(2 marks)**

QUESTION 2 (20 MARKS)

- a. Draw and clearly label **all** the longitudinal veins of a generalized insect wing **(8 Marks)**

- b. What is the main function of the second segment of an insect body? (1 mark)
- c. In case of an alate insect, which insect body are the wings located? Note: Be specific. (2 marks)
- d. With an aid of a diagram draw an insect egg and label all the parts. (9 marks)

QUESTION 3 (20 MARKS)

- a) What is the difference between elytra and hemelytra? Give examples of both the orders of insects and common name of an insect exhibiting the mentioned wing adaptation. (3 marks)
- b) The diagram below illustrates an adult female snow Scorpionfly. Mark and label the following parts of the body: A. Pronotum B. Tergites C. Sternites D. Vertex E. Pedicel, F. Scape, G. Femur, H. Pleural membrane, I. Meso-thoracic leg, J. Claws, K Tibia, L. flagellomeres, M. Tarsomeres, N. Pre-tarsus, O. Trochanter (15 Marks)

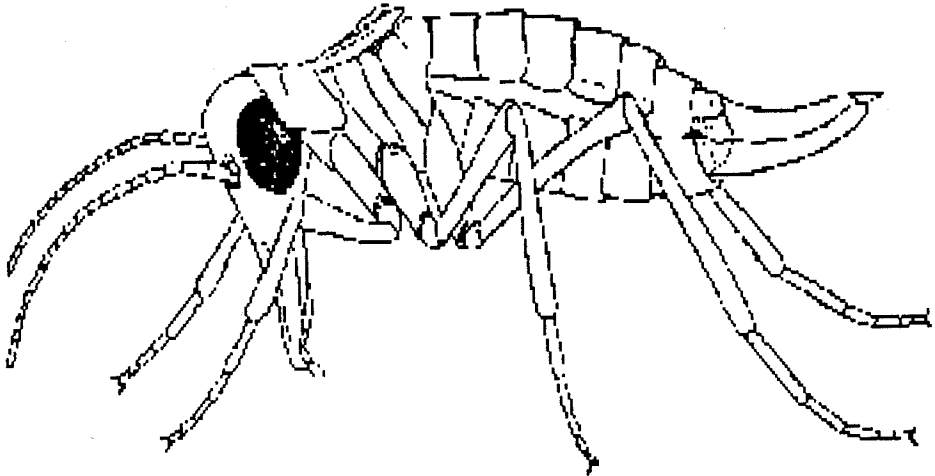

- c) The female snow Scorpionfly above what type of mouthparts does it exhibit? Justify your answer. (2 Marks)

SECTION 2: Applications of Entomology

QUESTION 4 (20 MARKS)

Briefly and concisely differentiate the following terms as used in Entomology

- i. Acute and Chronic insecticide toxicities
- ii. Inoculative and Inundative releases of insect pests' natural enemies
- iii. Solitary and Gregarious parasitoids

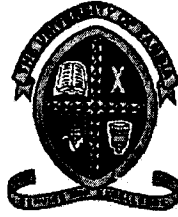

**The University of Zambia
School of Agricultural Sciences
Department of Plant Science**

**Fifth Year Examination for Bachelor of Agricultural Sciences
AGC 5125: SUSTAINABLE AGRICULTURE
Final Examination 2021/2022**

Date: Friday 11th November, 2022 Time: 14:00 –17:00 HRS

Venue: Omnia 2

Instructions:

1. Answer all questions.
2. Marks as indicated

Question 1 (15 Marks)

- a) What are the defining characteristics of Agro-ecological Regions of Zambia, especially with respect to Mega-environments in agricultural production? (3 Marks)
- b) Why is the definition of the USA Congress Farm Bill of 1990 more appropriate for sustainable agricultural production? (3 Marks)
- c) Describe farming practices, which can lead to a sustainable farming system. (3 Marks)
- d) Why is the livelihood approach deemed appropriate in understanding the food, nutritional and economic viability of a community? (3 Marks)
- e) Give examples of external environments that influence livelihoods. (3 Marks)

Question 2 (20 Marks)

The suitability of crop production in all the three Agro-ecological Regions of Zambia is shown in Figure 1.

- i) How was the crop suitability map developed? (10 Marks)
- ii) Explain the significance of the map to crop production in the country. (10 Marks)

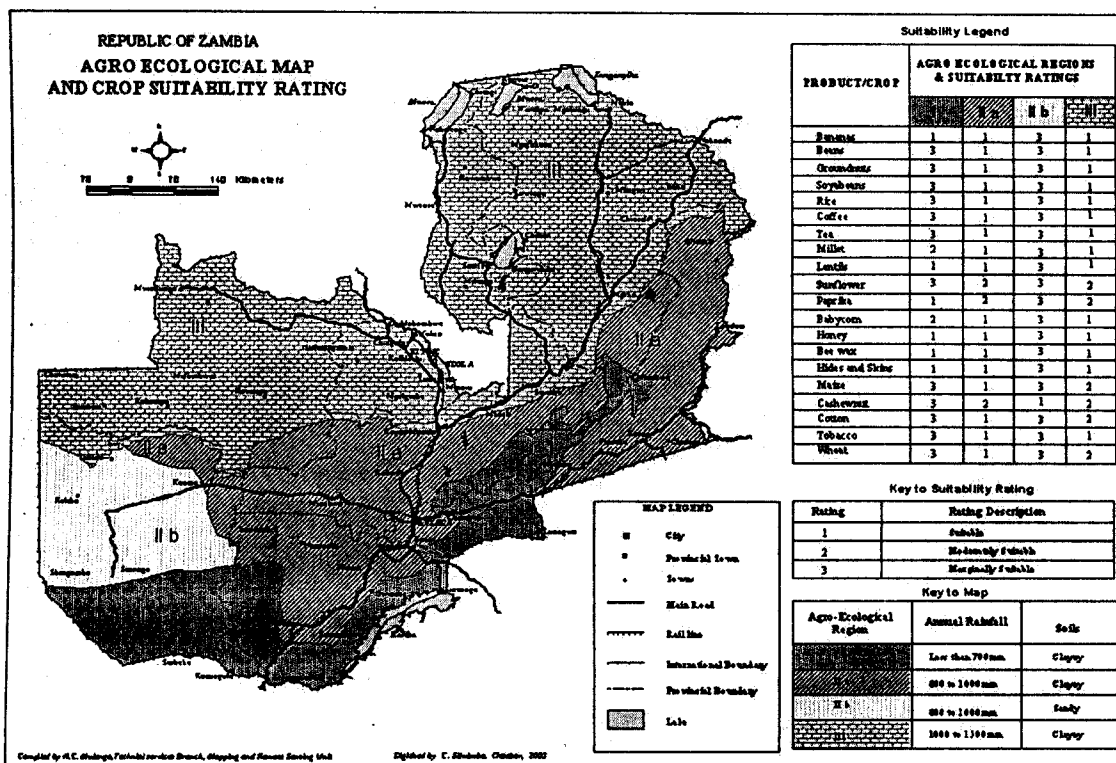

Figure 1: Crop suitability in all the Agro-ecological Regions of Zambia

Question 3 (25 Marks)

A. The objectives of the National Agricultural Policy (NAP 2012–2030) are shown below:

- 1) Promote sustainable increase in agricultural productivity of major crops with comparative advantage;
- 2) Continuously improve agricultural input and product markets so as to reduce marketing costs of agribusiness, including small-scale farmers and farmer groups;
- 3) Increase agricultural exports to preferential markets at regional and international levels;
- 4) Improve access to productive resources and services for small-scale farmers, especially women and young farmers, in outlying areas to enable them to increase production of staple foods, including fruits and vegetables, for own consumption and the surplus for income generation;
- 5) Continuously strengthen public and private sector institutional capabilities to improve agricultural policy implementation, resource mobilization, agriculture research, technology dissemination, and implementation of regulatory services.

- B.
- i) How does the expected crop production or more precisely cost of crop production given in the Crop Focus Survey Data in Table 1 inform the National Agricultural Policy (2012–2030)? (15 Marks)
 - ii) What policy option will you put in place to ensure that crop production is responding to the National Agricultural Policy? Refer in particular to objectives 1 and 4? (10 Marks)

Table 1: Crop focus survey data of 2018

NUMBER	AGRO- ECOLOGICAL REGION	CROP	EXPECTED PRODUCTION (MILLION METRIC TON)	UNIT COST (ZMK/MTON)
1	2A	Burley tobacco	1,178.73	26,400.00
3	2A	Paprika	547.59	12,800.00
	2A	Vwivet bean	764.69	15,000.00
4	2A	Pineapples	475.98	14,240.00
5	2A	Popcorn	433.81	10,000
6	2A	Finger Millet	363.94	19,800.00
7	2A	Maize	342.61	3,200.00
8	2A	Cashew nut	273.65	99,000
10	2A	Rice	74.24	28,000.00
11	2B	Burley tobacco	69.91	26,400.00
12	2B	Sugarcane (plantation)	41.14	70,400.00
13	2B	Pineapples	18.51	14,240.00
14	2A	Soya beans	16.04	7,674.00
15	2A	Sweet Potatoes	11.39	20,956.00
16	2A	Groundnuts	8.06	12,011.18
17	2A	Sunflower	1.89	28,875.00
18	2A	Cowpeas	1.65	5,115.00
19	2A	Seed cotton	1.43	3,630
20	2A	Mixed Beans	0.22	5,940

Question 4 (20 Marks)

Describe in order of importance only 5 **Key Tests of farming system being climate smart** from the 13 Key Tests on Climate Smart Agriculture given in Table 2. The Key Tests were expounded by Professor Vernon Chinene at the 3rd Agriculture Symposium on the theme “Enhancing Technology in Agriculture for Sustainable Food Systems and Economic Development” from 20–30 September 2022.

Table 2: Key tests of farming system being climate smart

Number	Key tests of farming system
1.	Soil management to enhance soil health
2.	Conservation agricultural practices (absence of conventional tillage)
3.	Biomass recycling (no crop residue burning)
4.	Efficient use of chemical fertilizers (fertilizing according to crop needs)
5.	Crop & livestock diversification and rotations
6.	Organic farming (generation of organic fertilizers within the farming system)
7.	Crop variety adaptation (use of climate resilient seed varieties)

8.	Water harvesting on-farm
9.	Integration of leguminous trees in the farming system)
11.	Harvesting and postharvest management (reduction of post-harvest losses)
12.	Presence of clean energy sources (e.g. on-farm biogas generation)
13.	Gender and social inclusion (sensitivity of the farming system to gender needs)

Question 5 (20 Marks)

- i) Explain the new paradigm of Sustainable Crop Intensification for sustainable crop production in the country. **(10 Marks)**
- ii) Why is Conventional intensification no longer a viable solution?: **(10 Marks)**

END OF EXAM



THE UNIVERSITY OF ZAMBIA

SCHOOL OF AGRICULTURAL SCIENCES

Bachelor of Agricultural Sciences undergraduate examinations

2022 academic year

AGC 5220 PLANT BREEDING AND QUANTITATIVE GENETICS

DATE: Wednesday November 9TH 2022, PM.

TIME: 3 HOURS

Answer Five questions only.

1.0 Write short notes on the following:

(20 Marks)

- Two forms of Insitu germplasm conservation
- Inbreeding depression
- Protogyny
- Linkage drag
- Somaclonal variation and its application in plant breeding

2.0 Write on any two of the following:

- The following are the yields of experimental Single Cross (F_1) hybrids arising from crossing inbred lines A, B, C, and D

F1 Hybrid	Yield (MT/HA)
A X B	8.8
A X C	8.9
A X D	8.4
B X C	9.2
B X D	8.0
C X D	8.1

Predict the performance of the Double Cross: $(A \times C) \times (B \times D)$ and a Three Way Cross: $(A \times B) \times D$ (10 marks)

- b. A land race variety of a self-pollinated crop is highly homozygous so that it is a waste of time attempting to use it as a base population for selection. **TRUE OR FALSE?** Explain. (10 marks)
- c. Hybrid vigour is expressed in many desirable forms in hybrid varieties for crop species that are amenable for hybrid variety development. List and briefly discuss five (5) forms of expressions of heterosis in crop species. (10 marks)

3.0 Discuss maintenance breeding activities for single cross hybrid maize varieties and for rice varieties (20 marks)

4.0 Rape seed or what is pleasantly known as Canola (*Brassica napus* $2n = 38$) is an important edible oil crop in the U.S, Canada, Australia and China. A study of the *fatty acid* profile of one of the progenitors of *B. napus* found in Mongolia, *B. oleracea* ($2n = 18$) was found to have very low *erucic acid* and high in *glucosinolate fatty acid*, the most desirable fatty acid profile and highly sought after in the cultivated *B. napus*. The other progenitor of *B. napus*, is *B. campestris* ($2n = 20$) which is a widely cultivated vegetable, popular among a small semi nomadic tribe, the Yizidi, in the Anatolian plateau of Turkey. This progenitor is highly resistant to aphids and to powdery mildew.

If you were to start a breeding program to introgress these highly desirable traits of fatty acid and aphid and powdery mildew in the cultivated Canola, what would be your approach? Explain clearly. (20 marks)

5.0 The ministry of livestock has embarked on a program to improve the availability of forages for cattle and small ruminant animals such as goats during the dry season. A pilot project by the ministry of livestock known as "Enhanced Small holder Livestock Production" (ESLIP) has recruited 100 emergent farmers (*Facilitated with basic irrigation equipment*) and 10 commercial farmers (*who already have elaborate irrigation facilities*) to grow maize for silage under irrigation along the Zambezi and Kafue river frontage to improve animal feed in the dry season.

Suppose you as a Plant Breeder have teamed up with Animal Scientists from the ministry and have been tasked to develop OPV varieties especially suitable for silage making, how would you proceed with your research and what is the anticipated Value Addition you would expect from the other team members in this task. (20 marks)

NOTE: The two critical requirements for silage varieties are high Biomass production and high Digestibility.

- 6.0 A group of grain traders from India attending a field day at GART were excited about a particular Single Cross white maize hybrid developed by ZARI. These traders expressed great interest to market that maize hybrid variety in Indian because of its unique ability to withstand water lodging for up to of five weeks without being damaged (as you know maize does not like to have its feet wet). They offered to go into contract with ZARI worth \$1,000,000 per year. However they would like ZARI to convert this variety from a white to a yellow maize variety.

Clearly explain how ZARI can convert this variety within two years in order not to lose this lucrative contract with the Indian traders.

Assume a morphological marker exists that identifies plants with the yellow trait in the seedling stage.

NOTE: Yellow is dominant to white.

(20 Marks)

- 7.0 What do you understand about the Ideotype concept? If you were to develop an ideotype for maize and rice, what would be your five ideotype traits for maize and five ideotype traits for rice in Zambia?

Give **sound scientific** reasons for your ideotype model for these two crops (20 Marks)

- 8.0 A politician passionately argued that the Variety Release Committee (VRC) whose secretariat is the Seed Control and Certification Institute (SCCI) is confusing the farming public by releasing too many varieties such that farmers do not know which variety to grow. He asked why the country, as small as Zambia, has more than 30 seed companies some of which are so huge that their budget is even more than that of the country! He lamented saying “where are our traditional varieties? Where is Gankata? Where is Kapyabwangu?” He went on in his rather emotional criticism that ZARI ought to stop developing any more varieties of maize. There are just too many varieties on the market and the Government should stop all these new seed companies from confusing the public with their *foreign varieties*.

Are the sentiments of this politician valid? **Discuss.**

(20 Marks)

-----END OF EXAMINATION-----

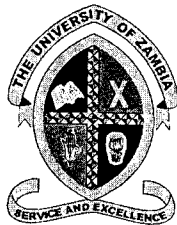

UNIVERSITY OF ZAMBIA

UNIVERSITY OF ZAMBIA EXAMINATIONS- JUNE 2022

AGC 5421

ADVANCED HORTICULTURE EXAMINATION

Time Three (3) hours.

Marks 100

INSTRUCTIONS:

- i. Answer any five (5) questions.
- ii. All questions carry equal marks.

-
1. Discuss the importance of horticultural nurseries and specifically how a unregulated nursery industry can impede the performance of the horticultural industry in Zambia. [20 marks]
 2. Contrast the ecological (water, temperatures) and planting (soils, spacing) needs of cashew (*Anacardium occidentale*), citrus (*Citrus* spp) and avocado (*Persea americana*). [20 marks]
 3. Discuss importance of indigenous plants in horticulture. In your answer, briefly describe one plants each in the following categories of ornamentals, vegetables and fruits. [20 marks]
 4. Describe three (3) glazing materials. In your answer include strengths and weaknesses of each. [20 marks]
 5. Briefly describe
 - a. Key considerations when landscaping a small urban property.
 - b. Landscape elements.
 - c. Ecological and chemical characteristics of nursery media [20 marks]
 6. Discuss bananas (*Musa* spp) production under the following
 - a. Botanical characteristics
 - b. Varieties
 - c. Ecology requirements.
 - d. Water and nutrient requirements. [20 marks]
-

END OF EXAMINATION



THE UNIVERSITY OF ZAMBIA
SCHOOL OF AGRICULTURAL SCIENCES
DEPARTMENT OF PLANT SCIENCE

Fifth Year Examination for Bachelor of Agricultural Sciences
AGC 5612: Seed Science and Technology
2022 Final Examination

OCTOBER 2022

TIME ALLOWED: THREE HOURS

Instructions: Section A is compulsory but choose **any three (3)** questions from Section B

SECTION A (40 MARKS): COMPULSORY QUESTION

Question 1

- a. Define 'Seed Technology' and explain any of its two aims. (6 marks)
- b. Briefly explain the concept, 'Variety Denomination'. (5 marks)
- c. Discuss the concept of the 'The Buying Operation' in seed marketing (6 marks)
- d. List any four noxious weeds, not tolerated during seed inspection. (4 marks)
- e. List in a logical order the seven classes of the certification scheme of Zambia. (7marks)
- f. List any three factors that affect seed germination. (3 marks)
- g. Why it is more costly to produce a single-cross hybrid than a three-way cross hybrid? (3 marks)
- h. You are in charge of the seed company which has recently developed a maize OPV popcorn variety, MM412. Dar Milling approaches you to **supply them 50,000 bags x 50 kg** of the same variety. You have **12 bags x 50 kg** of the seed available, how many cropping seasons will you need to multiply the initial seed to meet the demand? The multiplication factor is given to be **25**. Show all your working (6 marks)

[TURN THE PAGE]

SECTION B (60 MARKS): ANSWER ANY THREE QUESTIONS

Question 2 (20 Marks)

Write short notes on the following: ✓

- i. Seed Vigour
- ii. Hypogeal type of germination
- iii. Seed pricing
- iv. Post-control plots

Question 3 (20 Marks)

- a) Explain any four factors that affect the longevity of seed in storage (8 marks)
- b) Explain the three benefits of seed treatment (6 marks) ✓
- c) Why is seed packaging important? (3 marks)
- d) List any 3 types of seed packaging materials (3 marks) ✓

Question 4 (20 Marks)

- a. You are a seed inspector, working for SCCI. What aspects would you take into consideration when evaluating an OPV maize seed variety from vegetative to harvest stage, in order to effectively enforce the production standards? (11 marks)
- b. Discuss the three approaches to marketing (9 marks)

Question 5 (20 Marks)

- a) Discuss the internal and external seed quality control systems in Zambia. (10 marks)
- b) Discuss the merits and demerits of the informal seed system (10 marks)

END OF EXAMINATION



THE UNIVERSITY OF ZAMBIA
UNIVERSITY FINAL EXAMINATIONS-NOVEMBER 2022

AGC 5712 POST HARVEST TECHNOLOGY

Duration: Three (3) hours

Instructions:

- i. Read the questions carefully before answering.**
 - ii. Answer six (6) questions; three (3) from each section.**
 - iii. Answer each section in a separate and clearly labelled answer booklet.**
-

SECTION A

1. Discuss standards and their importance to food quality. In your answer, include drivers of standards and key characteristics of combination and provenance standards. **[16 marks]**
2. Discuss the following:
 - a. Physiological deterioration of produce.
 - b. Environmental factors that affect product quality. **[16 marks]**
3. Describe the essential elements of a quality control programme. **[16 marks]**
4. Distinguish between quantitative losses and qualitative losses. Suggest how each category of losses can be measured. **[16 marks]**

SECTION B

Question 1

- a. Name the solution made when salt is added to water. **[1 mark]**
- b. In cut flowers, additional carbohydrates are provided.
 - i. In what form are the additional carbohydrates? **[1 mark]**
 - ii. Give reason(s) for providing additional carbohydrates. **[2 marks]**
 - iii. List examples of commercial products marketed as additional carbohydrates. **[2 marks]**
- c. Tarpaulins are used during transportation of harvested produce from the field to the packinghouse. Briefly explain the use of tarpaulins. **[6 marks]**
- d. Briefly discuss the importance of curing Garlic (*Allium sativum*). **[6 marks]**

Question 2

- a. Name the causal organism of the disease which causes spoilage by covering Citrus fruits with green spores which are similar to those of Green mold. **[4 marks]**
- b. A decelerator curtain is used when packing Citrus fruits mechanically. Indicate the type of injury that is inflicted on the produce during packing. As a Supervisor in the packing section, what measures would you institute to ensure that products are not damaged during the process? **[6 marks]**
- c. Name the types of injuries that occur at any stage of the postharvest handling chain. Briefly explain the cause of each named injury. **[8 marks]**

Question 3

- a. Describe dehydration, the preservation method which is used in processing vegetable produce. **[8 marks]**
- b. The presence of ethylene in storage is detrimental to flower products. What measures can be undertaken to mitigate this problem? **[8 marks]**

END OF EXAMINATION



THE UNIVERSITY OF ZAMBIA
UNIVERSITY EXAMINATIONS – SUPPLEMENTARY 2021
AGE 2111
FUNDAMENTALS OF MICRO-ECONOMICS

TIME: 2 Hours

Marks: 100

INSTRUCTIONS: ANSWER ALL THE QUESTIONS AND WRITE LEGIBLY

1. Given the following market demand function for the commodity X:

$$Q = f(P_x, P_y, P_z, I, T, A)$$

Where: P_x = Price of commodity X, P_y = Price of substitute commodity Y, P_z = Price of commodity Z which is complement of X, I = Level of per capita income of consumers, T = Tastes and Preferences, A = Advertising expenditure by firm producing X

How will the market demand for a commodity change?

- a. If price of the commodity X rises (**5 marks**)
 - b. If price of the good Y rises (**5 marks**)
 - c. If price of good Z falls (**5 marks**)
 - d. Per capita income rises (**5 marks**)
 - e. Advertising expenditure increases (**5 marks**)
2. Consider a competitive market for which the quantities demanded and supplied at various prices are given as follows:

Price	Demand	Supply
60	22	14
80	20	16
100	18	18
120	16	20

- a. Define price elasticity of demand **(4 marks)**
- b. Calculate the price elasticity of demand when the price is 80 and when 100 **(8 marks)**
- c. Calculate the price elasticity of supply when the price is 60 and when 120 **(8 marks)**
- d. Suppose the government sets a price ceiling of 80, will there be a shortage or surplus and if so quantify it. **(5 marks)**

3.

- a. Indicate either **True** or **False** for each of the following statements: **(10 marks)**
 - i. Short run average total cost equals average fixed cost plus average variable cost.
 - ii. In a monopoly industry, the firm produces a differentiated product.
 - iii. The long run average cost curve declines because of diseconomies of scale.
 - iv. In a production function graph, all points below the production function are feasible.
 - v. In a fixed proportions production function with two inputs, a firm can increase output by increasing one of the inputs while keeping the other fixed.

b.

- i. What is a production function? **(5 marks)**
- ii. Does the production function remain the same when technology changes? **(4 marks)**

- c. Mention three (3) characteristics of a monopolistic competition market structure.

(6 marks)

4. Mr. Mwale has been working as an accountant for the past 10 years earning a salary of ZMW250,000 per year. Suppose he decides to leave his job, collects his terminal benefits and decides to start farming on a piece of land he inherited from his parents several years ago. Previously, he was renting the piece of land out at ZMW20,000 per year. To do this, he buys a second-hand tractor at ZMW 2,000,000 on a used tractor and ZMW50,000 on other inputs and workers salaries in the first year of operation. At the end of the year, he harvests and sells crops worth ZMW3,000,000. Suppose further that after the first year of use, the

tractor can be sold for ZMW1,700, 000 if he decided to sell it. His entrepreneurial skill could have earned him ZMW300,000 if he had started a different kind of business venture.

Calculate the following items for Mr. Mwale's first year of farming:

- a) Explicit costs. **(5 marks)**
- b) Implicit costs. **(5 marks)**
- c) Economic costs. **(5 marks)**
- d) Economic profits **(5 marks)**
- e) Accounting profits. **(5 marks)**

-----END OF EXAMINATION-----

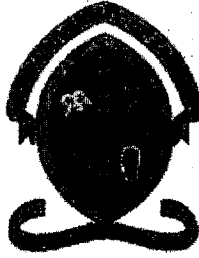

THE UNIVERSITY OF ZAMBIA
Department of Agricultural Economics and Extension

2022 Academic Examination

AGE 2122 Fundamentals of Macroeconomics

Duration: Three (3) hours

INSTRUCTIONS: The marks for each question are as indicated. Answer **ALL** the questions.

1) Given the following economic system:

	$Y = C + I + G + X - M$	
$C = 200 + 0.8y_d$	Consumption function	
$I = 100$	Investment function	
$G = 100$	Government expenditure	
$T = 20 + 0.5Y$	Tax function	
$X = 50$	Exports	
$M = 10 + 0.4Y$	Imports	
$Y_f = 640$	Full employment output	

- a. What is the equilibrium level of output? (4 marks)
 - b. What is the state of government budget? (4 marks)
 - c. Is the balance of trade in deficit or surplus at the equilibrium level of output? (4 marks)
 - d. What is the value of the multiplier in this economy? (4 marks)
 - e. Is there a deflationary or inflationary gap? (4 marks)
- 2) Answer the following question:
- a. Explain how the gross domestic product (GDP) is defined and measured(5 marks)
 - b. Describe the business cycle and its primary phases(5 marks)
 - c. Differentiate between equilibrium GDP and full employment GDP (5 marks)
 - d. Distinguish between cost-push inflation and demand-pull inflation(5 marks)

- 3) Explain what the following concepts and terms mean:
- Natural rate of unemployment. (4 marks)
 - Unemployment rate. (4 marks)
 - Intermediate goods. (4 marks)
 - Multiplier. (4 marks)
 - Crowding out effect (4 marks)
- 4) Explain and illustrate (*using graphs*) the effects, if any, that each of the following occurrences might have on the aggregate demand curve
- The Bank of Zambia lowers the discount rate (4 marks)
 - The price level increases (4 marks)
 - The government increases income tax (4 marks)
 - Pessimistic firms decrease investment spending (4 marks)
 - Government increases purchases to stimulate the economy (4 marks)
- 5) You are given the following account for a named commercial bank

<i>Assets</i>		<i>Liabilities</i>	
<i>Reserves</i>	500	3500	Deposits
<i>Loans</i>	3000		

- How much is the bank required to hold as reserves given its deposits of 3500? (3 marks)
- How much are its excess reserves. (5 marks)
- By how much can the bank increase its loans (5 marks)
- Suppose a depositor comes to the bank and withdraws 200 in cash. Show the Bank's new balance sheet, assuming the bank obtains the cash by drawing down its reserves. Does the bank now hold excess reserves? Is it meeting the required reserve ratio? If not what can it do? (7 marks)

=END OF EXAMINATION=

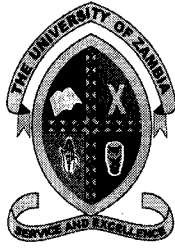

THE UNIVERSITY OF ZAMBIA
UNIVERSITY DEFERRED AND SUPPLEMENTARY EXAMINATIONS
2020/21 ACADEMIC YEAR

AGE 3031
INTERMEDIATE MICROECONOMICS

TIME: 2 HRS

MARKS: 100

INSTRUCTIONS:

1. This examination paper has **THREE (3)** questions. Answer **ALL** questions.
 2. Marks for each question are shown in parenthesis. Therefore, allocate your time appropriately.
 3. Please be concise when answering the questions and write legibly.
 4. Show all your work to earn you partial credit.
-

1. Consider a consumer with the following utility function

$$U(X, Y) = X^{0.2}Y^{0.8}$$

- a) Derive the marginal rate of substitution (MRS). **[6 marks]**
- b) Is the function derived in part a) consistent with diminishing MRS? Show your work and explain. **[3 marks]**
- c) Suppose the price of X is P_X and the price of Y is P_Y and the consumer's income is M :
 - i. Derive the Marshallian demand function for good X and good Y using the Lagrangian approach. **[14 marks]**
 - ii. Derive the consumer's indirect utility function. **[5 marks]**
 - iii. Derive the expenditure function. **[6 marks]**
 - iv. Derive the Hicksian demand functions. **[6 marks]**

2. Consider a firm with the following Cobb-Douglas production function

$$q = 100KL$$

- a) Derive the marginal rate of technical substitution. **[6 marks]**

- b) Does this production exhibit increasing, decreasing or constant returns to scale? Show your work and explain. **[3 marks]**
- c) Suppose the wage rate for labour is w and the rental rate of capital is r :
- Derive the optimal levels of K and L using the Lagrangian approach. **[15 marks]**
 - Derive the total cost function. Is the function an increasing, decreasing or constant function of quantity? **[6 marks]**

3. Suppose the market supply function of soya beans in Lundazi is given by the following function:

$$P = (Q + 1)^2$$

Where Q is in million kg and P is in K per kg

- If the price is K10 per kg, what would be the producers' surplus? Show your work and depict the producers' surplus on a well-labelled graph. **[12 marks]**
- If the price is K5 per kg, what would be the producers' surplus? Show your work and depict the producers' surplus on a well-labelled graph. **[12 marks]**
- Compute the change in producers' surplus of the fall in price from K10 to K5. Interpret your result. **[6 marks]**

----- END OF EXAM-----

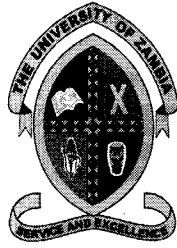

THE UNIVERSITY OF ZAMBIA
UNIVERSITY DEFERRED AND SUPPLEMENTARY EXAMINATION
2020/21 ACADEMIC YEAR

AGE 3042
INTERMEDIATE MACROECONOMICS

TIME: 2 HRS

MARKS: 100

INSTRUCTIONS:

1. This examination paper has **THREE (3)** questions. Answer **ALL** questions.
 2. Marks for each question are shown in parenthesis. Therefore, allocate your time appropriately.
 3. Please be concise when answering the questions and write legibly.
 4. Show all your work to earn you partial credit.
-

1. Consider an economy with the following Cobb-Douglas production function, $Y = 200\sqrt[3]{KL}$.
 - a) What does the parameter 200 stand for? Briefly explain. **[2 marks]**
 - b) Does this economy's production function exhibit constant returns to scale? Show your work. **[4 marks]**
 - c) Set up this economy's maximization problem and solve for the real wage and real rental rates of labour and capital respectively. **[8 marks]**
 - d) Assuming this economy operates in a competitive environment, show whether or not the economic profit generated is equal to zero. **[8 marks]**
 - e) What proportion of the total national income will go to labour? Show your work. **[6 marks]**
 - f) What proportion of the total national income will go to capital? Show your work. **[6 marks]**
 - g) Now, suppose there are xenophobic attacks on migrant labour in this economy that significantly reduce the number of workers available in the economy, what would be the effect of this change on the labour market equilibrium? Explain and depict the changes on the relevant graph. **[6 marks]**

2. Consider a small open economy described by the following equations:

$$Y = C + I + G + NX$$

$$Y = 10,000$$

$$G = 2,500$$

$$T = 2,000$$

$$C = 300 + 0.6(Y - T)$$

$$I = 1,500 - 50r$$

$$NX = 2000 - 500\epsilon$$

$$r = r^* = 8$$

- a) In this small open economy, compute the following: (i) national saving; (ii) investment; (iii) net exports, and; (iv) the equilibrium real exchange rate. Show the exchange rate equilibrium on a clearly labelled graph. **[15 marks]**
- b) Suppose the government in this open economy decides to raise taxes to 2500. Compute and explain the changes in the following: (i) national saving; (ii) investment; (iii) net exports, and; (iv) the equilibrium exchange rate. Be sure to draw a separate clearly labelled diagram showing the equilibrium before and after the change in taxes. **[20 marks]**

3. Consider an economy with the following Cobb-Douglas production function:

$$Y = K^{0.4}L^{0.6}$$

- a) Derive the per worker production function. **[4 marks]**
- b) Assuming the economy's saving rate is 40% and the rate of depreciation of capital is 5%, compute the steady-state capital per worker level. Depict this steady state on a well labelled graph showing all the relevant functions. **[9 marks]**
- c) Suppose the economy's saving rate is adjusted upwards to 50% while the depreciation rate remains at 5%, compute the steady state capital per worker level. Show the effects of the new saving rate and depict the new steady-state on a well labelled graph showing all the relevant functions. **[12 marks]**

----- END OF EXAM-----

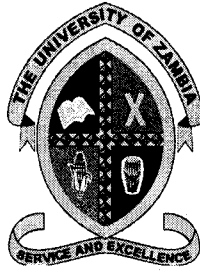

**THE UNIVERSITY OF ZAMBIA
SCHOOL OF AGRICULTURAL SCIENCES
DEPARTMENT OF AGRICULTURAL ECONOMICS AND EXTENSION**

**FINAL EXAMINATIONS
2021/22 ACADEMIC YEAR**

<u>PROGRAMME:</u>	BACHELOR OF SCIENCE IN AGRICULTURAL ECONOMICS
<u>COURSE NAME:</u>	INTERMEDIATE MACROECONOMICS
<u>COURSE CODE:</u>	AGE 3042
<u>DURATION:</u>	THREE HOURS

INSTRUCTIONS TO CANDIDATE:

1. This examination paper has two sections. Section A has three (3) standalone questions and Section B has three (3) questions with parts.
 2. Read all the questions carefully and answer all questions in both sections.
 3. Points for each question are shown in parenthesis. Therefore, allocate your time appropriately.
 4. Please be concise when answering the questions and write legibly.
 5. Show all your work on quantitative questions to earn you partial credit.
-

SECTION A

1. Describe in detail the steps taken to compute the year-on-year inflation rates using the gross domestic product deflator and the consumer price index methods. **[10 marks]**

2. With the aid of a properly labelled loanable funds model diagram, explain the effects of an increase in government spending on total savings, net exports and real interest rates in a freely trading small country. *Assume the world real interest rate is greater than the interest rate in a closed economy case and that consumption is a function of disposable income and real interest rates.* **[10 marks]**

3. Suppose there is a positive supply shock in agricultural markets due to favorable weather conditions. With the aid of a clearly labelled aggregate demand and supply diagram, explain the effects of this positive supply shock on price and output levels. What stabilization policy can be implemented to accommodate this positive supply shock and what would be the effect of the policy? Show this effect of the policy on a separate clearly labelled aggregate demand and supply diagram. **[10 marks]**

SECTION B

1. Consider an economy with the following Cobb-Douglas production function:

$$Y = K^{1/3}L^{2/3}$$

- a. Set up this economy's maximization problem and solve for the real wage and real rental rates of labour and capital respectively. **[10 marks]**

- b. Assuming this economy operates in a competitive environment, show whether or not the economic profit generated is equal to zero. **[8 marks]**

- c. Suppose there is a deliberate government policy to increase migrant labour into this economy, explain the effect of this policy on the labour market equilibrium. Depict the policy effects on the relevant graph assuming the economy is in the long run. **[7 marks]**

2. Consider an economy with the following Cobb-Douglas production function:

$$Y = K^{1/3}L^{2/3}$$

- a. Derive the per worker production function. **[4 marks]**

- b. Assuming the economy's saving rate is 40% and the rate of depreciation of capital is 15%, compute output per worker and capital per worker levels in the steady state. Show the steady state equilibrium on a well labelled diagram. **[8 marks]**

- c. Suppose the saving rate is increased to 50% but the rate of depreciation of capital remains at 15%, compute output per worker and capital per worker levels in the new steady state. Show the new steady state equilibrium on a another well labelled diagram. **[8 marks]**

3. Consider a closed economy described by the following equations:

Equation	Definition
$G = 10,000$	Level of government spending
$T = 15,000$	Level of taxes
$C = 1,000 + 0.6(Y - T)$	Consumption function
$I = 2,000 - 500r$	Investment function
$(M/p)^d = Y - 1,000r$	Demand for real money balances
$(M/p)^s = 5,000$	Supply of real money balances

- Is the government budget in surplus or deficit? Show your work. **[2 marks]**
- Compute the equilibrium level of income and interest rate in this economy and show this on a well labelled IS-LM model diagram. **[13 marks]**
- Suppose government increases spending from 10,000 to 15,000 while other exogenous factors remain the same, compute the new equilibrium level of income and interest rate in this economy. Is this the result you were expecting? Briefly explain. **[10 marks]**

----- END OF EXAM-----

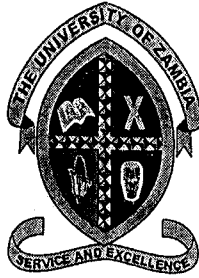

THE UNIVERSITY OF ZAMBIA

UNIVERSITY SUPPLEMENTARY EXAMINATIONS – FEBRUARY 2022

AGE 3381

RESEARCH METHODOLOGY

TIME: 2 Hours

Marks: 100

INSTRUCTIONS: ANSWER ALL QUESTIONS AND WRITE LEGIBLY

1. Distinguish between the following terms [12 Marks]

- a. Probability and Non- probability sampling. (6 marks)
- b. Systematic random sampling and stratified random sampling (6 marks)
- c. As part of a case study research based in an agribusiness firm with over 500 customers, you have been given access to an internal market research report, which the firm's marketing department undertook. The report presents results of a recent customer survey as percentages. The section in the report that describes how the data were collected and analysed is reproduced below:

Data were collected from a sample of current customers selected from our customer database. The data were collected using an online questionnaire designed and administered via the online software tool SurveyMonkey. Twenty-five customers responded, resulting in a 12.5 per cent response rate. These data were analysed using SPSS software. Additional qualitative data based on in-depth interviews with customers were also included.

Do you consider these data to be reliable? Give reasons for your answer. [13 Marks]

2. a) What are the advantages of using focus group discussions when collecting primary data? [10 Marks]
- b) You have won a consultancy bid for a Non-Governmental Organization (NGO) interested in developing the mango value chain in Zambia. Subsequently, you are expected to present your research proposal to the NGO directors. As part of the presentation, you outline your methodology, which includes pilot testing your questionnaire. In the ensuing question and answer session, one of the directors asks you to justify the need for pretesting of the questionnaire, arguing that the pretesting can be left out due to time and monetary constraints.

List the arguments you would use to convince her that pretesting the questionnaire is essential for your methodology. [15 Marks]

3. The following secondary data have been obtained from the Lubinda Ltd audited annual accounts:

Year end	Income	Expenditure
2012	11 000	9 500
2013	15 200	12 900
2014	17 050	14 000
2015	17 900	14 900
2016	19 000	16 100
2017	18 700	17 200
2018	17 100	18 100
2019	17 700	19 500
2020	19 900	20 000

- a) Which are the variables, and which are the cases or primary units of data in the data file? **[6 Marks]**
- b) What diagram would you use to emphasize the years with the lowest and highest income, give reasons for your choice? **[5 Marks]**
- c) Which measures of central tendency would you choose to describe the income over the period? Give reasons for your choice? **[7 Marks]**
- d) Which measures of dispersion would you choose to describe the income over the period and give reasons for your choice? **[7 Marks]**
4. a) Your research project supervisor has returned your draft research report with the suggestion that you make a clear distinction between your results/findings and discussion from your conclusions. How would you go about this, in other words what would you include in each of the three sections? **[12 Marks]**
- b) Why is it always considered good practice to acknowledge the limitations of your research in the project report? **[13 Marks]**

----- END OF EXAM-----

UNIVERSITY OF ZAMBIA
SCHOOL OF AGRICULTURAL SCIENCES
DEPARTMENT OF AGRICULTURAL ECONOMICS AND EXTENSION

AGE 4131 – PRODUCTION ECONOMICS

FINAL EXAM (REGULAR)

MONDAY 13TH JUNE 2022

DURATION: THREE HOURS

ANSWER ALL QUESTIONS

****PLEASE WRITE YOUR ANSWERS IN AN ORDERLY, CLEARLY AND LEGIBLE MANNER****

NOTE: READ THE INSTRUCTIONS AGAIN.

Question One (20 Marks)

- a. What is the difference between *Agricultural Economics* and *Production Economics*? (5 marks)
- b. What does it mean when we say that a firm operates in a *Purely Competitive Market*? (5 marks)
- c. What is the relevance of the *Purely Competitive Market Model* in the study of *Production Economics*? (5 marks)
- d. What is the relevance of the *Classical Production Function* in the study of *Production Economics*? (5 marks)

Question Two (20 marks)

Given the following total cost function: $TC = 98 + 4.8Y + 0.72Y^2 - 0.4Y^3$

- a. Derive the following equations/expressions
 - i. Total Fixed Costs (TFC) (1 mark)
 - ii. Total Variable costs (TVC) (1 mark)
 - iii. Average Fixed Costs (AFC) (2 marks)
 - iv. Average Variable Costs (AVC) (2 marks)
 - v. Marginal Cost (MC) (4 marks)
- b. Determine the quantity of output, Y, at the point where average variable cost (AVC) is minimum. (5 marks)
- c. Calculate the total cost (TC) for the output level computed in 'b' above (5 marks)

Question Three (20 marks)

Study the production function given below:

$$Y = 2X^2 - \frac{1}{9}X^3$$

- Derive the Marginal Physical Product (MPP) equation and determine its value when $X=10$ units. **(5 marks)**
- Derive the equation for the Average Physical Product and compute the value for the APP when $X=15$ units. **(5 marks)**
- In one diagram, draw and clearly label the classical production function (Total Physical Product, TPP), the APP and MPP curves. Comment on the different stages of the classical production function and the key distinguishing features that mark these different stages. **(10 marks)**

Question Four (20 marks)

- Find the equation of an Isocost line for two inputs, X_1 and X_2 , given that; $P_{X_1} = \$5$ and $P_{X_2} = \$20$ and the Total Variable cost of the Isocost line is \$130. **(10 marks)**
- Explain and illustrate graphically how Long Run Equilibrium is achieved. **(10 marks)**

Question Five (20 marks)

- Depreciation is made up of two components; Time Depreciation and Use Depreciation. Define these two types of depreciation and explain the main difference between them. **(5 marks)**
- What does it mean when an agribusiness firm is said to be 'living off depreciation'? **(5 marks)**
- You have been offered a large tract of farmland to purchase at K60,000. The seller has informed you that the land has the capacity to perpetually earn you K20,000 every year, irrespective of whatever agricultural enterprises you wish to venture into. Using a discount rate of 26%, evaluate whether it would be profitable to purchase the land at the offer price of K60,000. **(10 marks)**

End of Exam



THE UNIVERSITY OF ZAMBIA
UNIVERSITY EXAMINATIONS – NOVEMBER 2022
AGE 4142

AGRICULTURAL MARKETING AND PRICING

TIME: 3 Hours

Marks: 100

INSTRUCTIONS: ANSWER ALL QUESTIONS AND WRITE LEGIBLY

Section A

Indicate whether TRUE or FALSE and a one sentence justification for each of the following statements: **(10 Marks)**

1. Products sold in oligopoly markets may be identical or differentiated.
2. In a supply response relation, if price increases and then reduces by the exact same amount, equilibrium output returns to the same level as before the initial price change.
3. With time, price differentials change with shifts in the supply and demand functions.
4. A good grading system should result in all commodities in a particular grade being homogenous.
5. A monopoly firm will set price in the elastic part of the product's demand curve.

Section B

1.
 - a. What is an agricultural market?
 - b. Briefly explain one role of prices in marketing.

(8 Marks)
2.
 - a. What is predatory pricing?
 - b. Briefly explain the short-run and long-run consequences of predatory pricing for consumers

(8 Marks)
3. Use a clearly labeled graph to show the amplitude and length of a price cycle.

(5 marks)
4. Briefly explain two (2) advantages of marketing contracts for buyers of agricultural products.

(4 marks)
5. For each of the following, indicate whether the firm should increase or reduce price in order to increase the firm's revenue:
 - a. Inelastic demand
 - b. Elastic demand

(4 Marks)
6. Suppose a farmer has an option to sell her maize at two time periods; period 1 is today and period 2 in 3 months.
 - a. Under what conditions should she store to sell in period 2? **(5 Marks)**
 - b. Explain how the farmer's storage decision today will affect current and future prices in the market.

(10 Marks)
7.
 - a. Mention four (4) strengths of private enterprises in agriculture.
 - b. Briefly explain the three (3) factors that may determine the effectiveness of a marketing board.

(14 Marks)

8. Suppose bread demand is related to two commodities, rice and mealie meal, with cross price elasticities of demand 0.4 and 0.8 respectively. If bread is a normal good, comment on the own price elasticity of bread.

- Suppose bread is only related to mealie meal and the following:
- Proportion of expenditure on bread and mealie meal is 2 percent and 10 percent respectively,
- A 2 percent increase in the price of bread reduces quantity demanded of bread by 18 percent,
- A one percent increase in the price of mealie meal increases the price of cooking oil by 1.3 percent,
- A one percent increase in the price of bread increases the price of mealie meal by 0.5 percent,

Estimate the total elasticity of bread.

(15 Marks)

9. Suppose the price of soybean at Soweto market is K500/kg and K480/kg at Mtendere main market. The table below shows the distance of soybean producers from the two markets:

Farmer	Soweto Market		Mtendere Market	
	Distance to market (Km)	Net price	Distance to market (km)	Net price
A	8		0	
B	6		2	
C	0		8	
D	2		8	
E	14		10	
F	20		16	

- a. If transfer costs are K50 per kilometer,
- i. Complete the net price columns for each farmer in your answer book.

ii. Which market should each farmer sell to? Explain your answer.

(12 points)

b. With the aid of a diagram, show the market boundary for the two markets.

(5 points)

-----The End-----



THE UNIVERSITY OF ZAMBIA
UNIVERSITY EXAMINATIONS – NOVEMBER 2022

AGE 4222

INTERMEDIATE AGRIBUSINESS MANAGEMENT

TIME: 3 Hours

Marks: 100

INSTRUCTIONS: ANSWER ALL QUESTIONS AND WRITE LEGIBLY

Question 1

- a. The decision of where to locate an agribusiness is a strategic issue. Discuss this statement [10 Marks]
- b. Highlight the factors you would consider when choosing the location of a fish processing plant in Zambia [15 Marks]

Question 2

- a. Briefly discuss the seven sources of innovative opportunities as highlighted by Peter Drucker [15 Marks]
- b. When building a business idea, it is critical that you think a lot about the customer and the problem they have (Problem- first entrepreneurship) rather than focusing on the solution you have. What are the benefits of using this approach when developing a business idea? [10 Marks]

Question 3

If you were introducing a new electronic dairy feeding system that would reduce costs between 20 to 25 percent.

- a. What pricing policy would you suggest? Give reasons for your choice. [10 Marks]
- b. Would you stay with the policy indefinitely? Explain your answer [5 Marks]
- c. What promotional strategy would you use? [10 Marks]

Question 4

- a. (i) Why is the executive summary often considered the most important section of a business plan? [3 Marks]
(ii) Highlight the content of the business plan executive summary? [10 Marks]
- b. (i) Identify an agribusiness of your choice and highlight four key ongoing trends [4 Marks]
(ii) What opportunities and/or threats does each of the trends you have identified above pose for the agribusiness [8 Marks]

THE END

THE UNIVERSITY OF ZAMBIA

DEPARTMENT OF AGRICULTURAL ECONOMICS AND EXTENSION

**AGE 4311 QUANTITATIVE METHODS IN AGRICULTURAL ECONOMICS MID
YEAR EXAMINATION 2022**

INSTRUCTIONS: THERE ARE FOUR QUESTIONS

ANSWER ALL QUESTIONS, 100 MARKS; TIME: 3HRS

1. Mathematical programming (MP) is a very useful decision tool in agriculture and business. As briefly and as precisely as possible answer the following questions about MP.
 - a) Why do you think MP models are so important in business decisions? [4 points]
 - b) Linear programming (LP) is a special type of MP. List three other types of MP models and state how they differ from LP models. [6 points]
 - c) In research, LP fits within the framework of the scientific research process. Explain how LP fits into the scientific research process. [3 points]
 - d) All MP models have certain essential features/components. List the features/components of MP models. [4 points]
 - e) LP is always better than any other technique available to agricultural economists. True or false? Explain your answer. [3 points]

2. Use the following excerpt from the Excel Solver output to answer the questions below.

-----S-O-L-V-E-R--E-X-C-E-R-P-T--S-T-A-R-T-S-----

Constraints (from the answer report)

Cell	Name	Cell Value	Formula	Status	Slack
\$C\$5	Labour (months)	72	$\$C\$5 \leq \$D\5	Binding	0
\$C\$6	Land (ha)	20	$\$C\$6 \leq \$D\6	Binding	0
\$C\$7	Fertilizer (kg)	320	$\$C\$7 \leq \$D\7	Not Binding	280
\$E\$3	Maize	16.00	$\$E\$3 \geq 0$	Not Binding	16.00
\$F\$3	Wheat	4.00	$\$F\$3 \geq 0$	Not Binding	4.00

Adjustable Cells (from the sensitivity report)

Cell	Name	Final Value	Reduced Cost	Objective Coefficient	Allowable Increase	Allowable Decrease
\$E\$3	Maize	16.00	0.00	60	20	20
\$F\$3	Wheat	4.00	0.00	40	20	10

-----S-O-L-V-E-R--E-X-C-E-R-P-T--E-N-D-S-----

- a) Write out algebraically the objective function for this problem and compute its optimal value. [8 points]
- b) What is the optimal value of each of the real activities? [4 points]
- c) State the right-hand-side values for each of the resource constraints. [6 points]
- d) What is your expectation of the shadow price for fertilizer, explain? [5 points]
- e) What additional information do you need to be able to demonstrate that Euler's Theorem holds for this problem? [6 points]

3. A company is involved in the production of two items (X and Y). The resources needed to produce X and Y are twofold, namely machine time for automatic processing and craftsman time for hand finishing. The table below gives the number of minutes required for each item:

Item	Machine time	Craftsman time
X	13	20
Y	19	29

The company has 40 hours of machine time available in the next working week but only 35 hours of craftsman time. Machine time is costed at £10 per hour worked and craftsman time is costed at £2 per hour worked. Both machine and craftsman idle times incur no costs. The revenue received for each item produced (all production is sold) is £20 for X and £30 for Y.

- Formulate the LP problem of deciding how much to produce per week in order to maximize total revenue. **[5 points]**
 - Solve this linear program using the Simplex method. **[15 points]**
 - State the optimal objective function value and optimal levels of the real activities **[5 points]**
4. Assume we have 3 boxes which contain red and black balls as follows:
- Box 1: 3 red and 7 black
 - Box 2: 6 red and 4 black
 - Box 3: 8 red and 2 black
- Suppose we draw a ball from box 1; if it is red, we draw a ball from box 2. If the ball drawn from box 1 is black, we draw a ball from box 3.
- Now answer the following questions;
- What is the probability of red ball from box 1? **5 points**
 - Suppose we draw a ball from box 1 and it is red; what is the probability of another red ball when we draw from box 2 on the second round? **5 points**
 - Suppose our first draw from box 1 was black; what is the conditional probability of our second draw (from box 3 this time) being red? **5 points**
 - Before we draw any ball; what is the probability of drawing two red balls at both draws? **5 points**
 - Before we draw any ball; what is the probability of drawing a red ball at first draw and a black ball at second draw? **5 points**

GOOD LUCK!



**THE UNIVERSITY OF ZAMBIA
UNIVERSITY DEFERRED AND SUPPLEMENTARY EXAMINATIONS
2020/2021**

**AGE 4322
APPLIED ECONOMETRICS**

TIME: 2 HOURS

MARKS:100

INSTRUCTIONS:

1. ANSWER ALL QUESTIONS IN THIS EXAMINATION PAPER. BE CONCISE AND WRITE LEGIBLY.
 2. ANSWER QUESTION 1 AND 2 IN ONE ANSWER BOOKLET AND QUESTION 3 AND 4 IN A SEPARATE ANSWER BOOKLET.
-

1. Using data obtained through a nationwide survey of farming households in Zambia (dataset is called maize yield.dta), your AGE 5004 supervisor has given you an assignment to estimate a simple linear regression model stated below:

$$mzyield = \beta_0 + \beta_1fertha + \epsilon$$

where mzyield is maize yield in kilograms per hectare and fertha is kilograms of inorganic fertilizer applied per hectare of maize.

- a) Suppose you generate the following summary statistics in Table 1:

Table 1: Detailed Summary Statistics for Maize Yields in Zambia (2015)

```
. sum mzyield, det
```

kgs of maize harvested per hectare			
	Percentiles	Smallest	
1%	95.83334	0	
5%	380.9671	0	
10%	592.8889	0	Obs 7,160
25%	1150	0	Sum of Wgt. 7,160
50%	1987.654		Mean 2294.721
		Largest	Std. Dev. 1556.228
75%	3123.457	8912.5	
90%	4370	9228.396	Variance 2421845
95%	5331.173	9583.333	Skewness 1.173255
99%	7169.753	13800	Kurtosis 4.830464

- a. State and interpret the 5th, 10th, 75th and 90th percentiles of maize yields in Zambia. [12 marks]
- b. State and interpret the standard deviation of maize yields. [3 marks]
- c. Is the distribution of maize yields skewed to the right or to the left? Explain. [3 marks]

b) Suppose you generate the following regression results in Table 2:

VARIABLES	(1) mzyield
fertha	4.119*** (0.0780)
Constant	1,397*** (23.08)
Observations	7,160
R-squared	0.280

Standard errors in parentheses *** $p < 0.01$, ** $p < 0.05$, * $p < 0.1$

- a) Which variable is the dependent variable and which one is the independent variable? [1 mark]
 - b) State and interpret the goodness of fit. [3 marks]
 - c) Interpret the F test. Be sure to clearly state the null and alternative hypotheses and what your findings are. [4 marks]
 - d) Interpret the t test. Be sure to clearly state the null and alternative hypotheses and what your findings are. [4 marks]
2. At the beginning of your final year research project, you meet your designated supervisor to discuss your research. Your supervisor is aware that you have taken an applied econometrics course and would like you to respond to the following questions:
- a) With an example, explain why you would include a quadratic term in a multiple linear regression model. As part of your explanation, clearly state how you would generate a quadratic term in Stata and the test you would use whether to keep or not to keep the quadratic term in your model. [10 marks]
 - b) Suppose you want to run a log-log multiple linear regression model in Stata. Explain how you would implement the following:
 - i) Log transformation of your dependent variable, all continuous independent variables and all indicator independent variables. [5 marks]

- ii) Interpret the coefficients on the continuous independent variables and on the indicator independent variables. [5 marks]

3. Suppose you are running the following OLS regression in stata:

$$yield_i = \beta_0 + \beta_1 fertilizerkg_i + \beta_2 seedkg_i + \beta_3 area_i + e_i$$

where *yield* is sorghum yield in kgs/ha, *fertilizerkg* is the quantity of fertilizer applied, *seedkg* is the quantity of seed and *area* is the sorghum plot size. The dataset also includes a variable *farmsize* which is the farmer's total farm size.

- a) Briefly explain one visual approach you could use to detect potential heteroscedasticity in your model. [5 marks]
- b) Interpret the heteroscedasticity test results obtained from the following two versions of the Breusch-Pagan test in stata (use a 10 percent significance level) [6 marks]:

i)

```
Breusch-Pagan / Cook-Weisberg test for heteroskedasticity
Ho: Constant variance
Variables: fitted values of yield
```

```
chi2(1)      =      17.81
Prob > chi2  =      0.0000
```

ii)

```
Breusch-Pagan / Cook-Weisberg test for heteroskedasticity
Ho: Constant variance
Variables: farmsize
```

```
chi2(1)      =      3.68
Prob > chi2  =      0.0549
```

c)

- i) Write the stata command(s) needed to obtain least squares estimates that are consistent when heteroscedasticity is present. [2 marks]
- ii) Outline the steps you would use to correct for heteroscedasticity in this estimation assuming the observation's standard error, σ_i , is not known. [12 marks]

4. Suppose you would like to measure the effect of education on wages of till operators in Zambia using the regression model

$$\ln(wage)_t = \beta_0 + \beta_1 Educ_t + \beta_2 Exper_t + \beta_3 Exper_t^2 + e_t$$

where *lwage* is the natural logarithm of wage, *educ* is the highest education level attained in years, *exper* is work experience, and *exper2* the square of experience. You know, and have

confirmed using a hypothesis test, that education is endogenous because it may be correlated with ability and other factors in the regression error term.

- a) Under what conditions would the variable *mothereduc*, mother's education, qualify as a valid instrument for education in this model? **[4 marks]**
- b) Suppose you choose to perform two-stage least squares step by step in stata,
 - i) Write the first stage regression model using the variable *mothereduc* as an instrument. **[2 marks]**
 - ii) What will be the second stage regression model? **[2 marks]**
 - iii) Write the stata command(s) needed to perform the two-stage least squares regression using *mothereduc* as an instrument. **[8 marks]**
- c) Alternatively, you could use stata's built-in instrumental variable estimation procedure to correct for the endogeneity,
 - i) Write the stata command(s) needed to correct for endogeneity using the built-in procedure. **[4 marks]**
 - ii) Briefly explain how the coefficients, standard errors, t-statistics, p-values and confidence interval estimates obtained from this procedure compare with the estimation results from part (b). **[5 marks]**

----- END OF EXAM-----

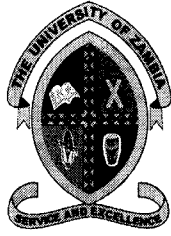

THE UNIVERSITY OF ZAMBIA
UNIVERSITY DEFERRED AND SUPPLEMENTARY EXAMINATIONS—2020/21

AGE 5151
INTERNATIONAL AGRICULTURAL MARKETS, TRADE AND DEVELOPMENT

TIME: 2 HOURS

MARKS: 100

INSTRUCTIONS:

1. This examination paper has two sections. Section A has twenty (20) multiple-choice questions and Section B has two (2) open ended questions. Answer all questions from both sections.
 2. Clearly show your work in your answers to Section B questions.
 3. Please be concise in answering the questions and write legibly.
-

SECTION A (60 marks)

1. [2 marks] Which of the following is not a very good explanation for why nations trade?
 - A. It enables consumers in the importing country to have a larger and more diverse bundle of goods and services available at lower overall prices
 - B. The World Trade Organization (WTO) mandates that nations should trade
 - C. The existence of comparative advantage produces an area of potential trade within which both countries can make better deals for themselves through international exchange than by adjusting its own resources internally
 - D. There are economy-wide gains from trade both from an exchange of goods and from the ability to specialize in production
2. [2 marks] "Zambia should promote exports and substantially minimise imports in order to create trade surplus." Which school of thought would you attribute this statement?
 - A. Humanism
 - B. Mercantilism
 - C. Capitalism
 - D. Socialism

3. [2 marks] Which of the following is not true about the Ricardian model?
- A. It assumes perfect competition
 - B. It assumes that there is only one factor of production, capital
 - C. It is a partial equilibrium model
 - D. Both B and C

Use the following table to answer questions 4 – 6. Suppose that labour can produce flowers or chocolate in country A and B. Below is the table that indicates the labour productivities in each country.

	Flowers	Chocolate
Country A	20 units/hour	120 units/hour
Country B	10 units/hour	30 units/hour

4. [4 marks] Which of the following is true?
- A. Country A has an absolute advantage in flowers
 - B. Country B has a comparative advantage in flowers
 - C. Country B has a comparative advantage in chocolate
 - D. Both A and B
5. [4 marks] Both countries would benefit if
- A. Country A produced both commodities and did not trade with Country B
 - B. Country B produced both commodities and did not trade with Country A
 - C. Country A exported chocolate and imported flowers
 - D. Country A exported flowers and imported chocolate
6. [4 marks] Which workers would experience an increase in real wages if the two countries specialized in their respective comparative advantage good and traded freely?
- A. Workers in Country A's chocolate industry
 - B. Workers in Country A's flower industry
 - C. Workers in Country B's chocolate industry
 - D. None of the workers
7. [2 marks] What theory of trade is appropriate to explain trade between countries with similar resource endowments?
- A. Ricardian Model
 - B. Absolute advantage theory
 - C. H-O model
 - D. Economies of scale in production

8. [2 marks] The theorem of the H-O model that states that if the price of the labour-intensive good rises then the price of labour will rise while the rental rate paid to capital will fall is called the:
- Heckscher-Ohlin theorem
 - Stolper-Samuelson theorem
 - Rybczynski theorem
 - Factor-Price Equalisation theorem
9. [2 marks] If Zambia is labour abundant, based on the H-O model, the group that would gain from trade is:
- Capitalists
 - Workers
 - Both groups would gain
 - No losers or gainers
10. [2 marks] The general version of the Rybczynski theorem is called the
- Magnification effect for quantities
 - Magnification effect for prices
 - Factor-price equalization theorem
 - H-O model
11. [2 marks] When economists say trade is not a zero sum game, they mean that
- The sum of the gains to the winners is exactly equal to the sum of the losses to the losers
 - The sum of the gains to the winners is less than the sum of the losses to the losers
 - The sum of the gains to the winners is greater than the sum of the losses to the losers
 - Countries are able to retaliate or engage in trade wars

Answer questions 12 – 13 by referring to the demand and supply of wheat for two trading partners

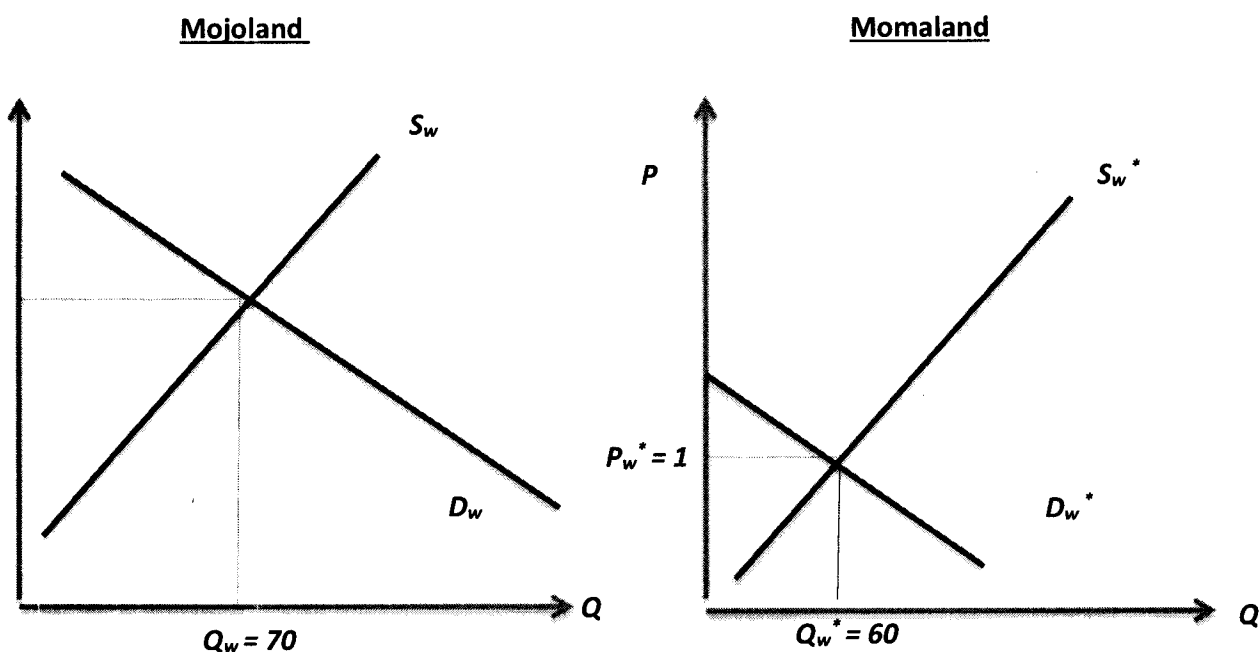

12. [3 marks] What is not true based on the information presented on these graphs?

- A. Mojoland will import wheat from Momaland in free trade
- B. Momaland will export wheat to Mojoland in free trade
- C. The free trade equilibrium price of wheat will be less than 1
- D. The free trade equilibrium price of wheat will lie between 1 and 3

13. [3 marks] What do the quantities 70 and 60 represent?

- A. Equilibrium quantities in free trade
- B. Equilibrium quantities in autarky
- C. 70 is the equilibrium quantity in free trade and 60 is the equilibrium in autarky
- D. 70 is the equilibrium quantity in free autarky and 60 is the equilibrium in free trade

Answer questions 14 – 16 by referring to the following trade policy game between two countries.

	(USA, Japan)	Japan	
		Free Trade	Optimal Tariffs
USA	Free Trade	(200, 200)	(140, 240)
	Optimal Tariffs	(240, 140)	(180, 180)

14. [4 marks] Assuming the two countries seek to optimise national welfare, would Japan retaliate if the USA decided to impose optimal tariffs?

- A. No, Japan would choose free trade
- B. No, Japan would choose not to play any of the available strategies
- C. Yes, Japan would choose optimal tariffs
- D. None of the above

15. [4 marks] Assuming the two countries seek to optimise national welfare, what would be Japan's best response strategy if the USA decided to go for free trade?

- A. Japan would choose free trade
- B. Japan would choose not to play any of the available strategies
- C. Japan would choose optimal tariffs
- D. Japan would be indifferent (they could choose free trade or optimal tariffs)

16. [2 marks] Does the outcome of this game as depicted by your answers to question 14 and 15 help justify a trade liberalization organization like the World Trade Organization?

- A. Yes
- B. No
- C. It depends on the size of the two countries in global markets
- D. It depends on the frequency of trade between the two countries

Use the economic data for a fictional country Sandia to answer questions 17-19.

Sandia Economic Data (billions)	
Gross Domestic Product	\$ 400
Imports of Goods and Services	\$ 140
Investment Spending	\$ 20
Private Saving	\$ 30
Exports of Goods and Services	\$ 100
Government Transfers	\$ 40
Government Tax Revenues	\$ 140
Government Spending	\$ 140
Consumption Spending	\$ 280

17. [4 marks] Based on the data, Sandia has a current account
- Deficit
 - Surplus
 - Of Zero
 - That cannot be determined
18. [4 marks] Based on the data, Sandia has a government budget balance
- Deficit
 - Surplus
 - Of Zero
 - That cannot be determined
19. [4 marks] Does Sandia's data satisfy the national income identity?
- Yes
 - No
 - We have less information to verify this
 - We have too much information to verify this

Use the information in the table below to answer question 20.

	Bread Price/loaf	Exchange Rate 23/10/2015
Zambia	ZMW 3.00	--
Botswana	BWP 4.95	0.55 ZMW/BWP
South Africa	ZAR 6.00	0.47 ZMW/ZAR

20. [4 marks] Based on the information in the table, the Kwacha is
- Undervalued relative to the BWP
 - Undervalued relative to the ZAR
 - Overvalued relative to the BWP but undervalued relative to the ZAR
 - Overvalued relative to both currencies

SECTION B (40 marks)

1. Country A is a “small” country in processed coffee markets. Domestic supply and demand curves in Country A are as follows:

$$S_C^A = 60 + 0.2 P_C^A$$

$$D_C^A = 180 - 0.8 P_C^A$$

where P_C^A is the price of processed coffee in \$/ton in Country A, and S_C^A and D_C^A are quantities in thousand tons. The price of processed coffee in Country B (representing the rest of the world) is \$100/ton.

- a) If the two countries were freely trading, what would be the pattern of trade and the prevailing equilibrium price and quantity traded of processed coffee? Graph this equilibrium using the export supply and import demand diagram. **[10 marks]**
 - b) Suppose Country A imposes a tariff of \$10/ton on imported processed coffee from Country B. Compute the welfare effects of this policy on all economic actors in Country A and Country B. Interpret your results and ensure to graph this tariff-ridden equilibrium on the domestic demand and supply diagram for Country A. **[15 marks]**
2. Compare and contrast the following international finance concepts:
- a. Current and financial accounts of the balance of payments. **[5 marks]**
 - b. Purchasing power parity and interest rate parity. **[5 marks]**
 - c. Floating and fixed exchange rate systems. **[5 marks]**

----- END OF EXAM-----

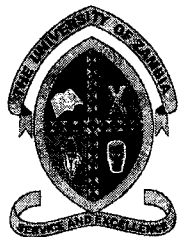

THE UNIVERSITY OF ZAMBIA
UNIVERSITY MID-YEAR EXAMINATIONS
2021/22 ACADEMIC YEAR

AGE 5151
INTERNATIONAL AGRICULTURAL MARKETS, TRADE AND DEVELOPMENT

TIME: 3 HRS

MARKS: 100

INSTRUCTIONS:

1. This examination paper has **TWO** sections. Section A has **THREE** computational questions and section B has **THREE** essay type questions. Answer **ALL** questions in both sections.
2. Marks for each question are shown in parenthesis. Therefore, allocate your time appropriately.
3. Please be concise when answering the questions and write legibly.
4. Show all your work to earn your partial credit.

SECTION A

1. Dreamland has two key industries—maize milling and oilseeds processing—for which data is provided in the table below.
 - Unit labour requirement for maize milling is 2 hours per ton of mealie meal
 - Unit labour requirement for oilseeds processing is 2 hours per ton of oilseeds
 - Unit capital requirement for maize milling is 1 hour per ton of mealie meal
 - Unit capital requirement for oilseeds processing is 3 hours per ton of oilseeds
 - Total labour endowment is 30,000 hours
 - Total capital endowment is 20,000 hours
 - Price of mealie meal per ton is \$400
 - Price of processed oilseed per ton is \$1,000

Answer the following questions:

- a) Compute and graph the equilibrium wage and rental rates, assuming perfect competition in the industries producing the two goods. [8 marks]
- b) Compute and graph the equilibrium quantities of mealie meal and processed oilseeds produced in Dreamland. [8 marks]
- c) If the price of processed oilseed reduces to \$500 while the price of mealie meal remains the same, which factor of production would gain from this price change? Explain and show your work. [4 marks]

2. Mushalaland is a small country in crude oil markets with the following domestic demand and supply equations:

$$D = 10,000 - 20P^M$$

$$S = 80P^M$$

P^M is the price of crude oil in Mushalaland in \$ per barrel. To satisfy domestic demand, Mushalaland imports crude oil from Savimbiland at a price of \$50/barrel.

- a) What will be the price of crude oil in Mushalaland if there are no trade restrictions prohibiting imports from Savimbiland? [1 mark]
 - b) In Mushalaland, how many barrels of crude oil will be supplied by domestic suppliers if there are no trade restrictions prohibiting imports from Savimbiland? [2 marks]
 - c) In Mushalaland, how many barrels of crude oil will be supplied by Savimbiland suppliers if there are no trade restrictions prohibiting imports from Savimbiland? [3 marks]
 - d) Depict the equilibrium on the domestic demand and supply diagram of Mushalaland if there are no trade restrictions prohibiting imports from Savimbiland. The equilibrium should include the prevailing price, quantity supplied by domestic suppliers and quantity supplied by Savimbiland suppliers. [3 marks]
 - e) Suppose the government in Mushalaland imposes a tariff of \$25/barrel, what will be the new price of crude oil in Mushalaland, the quantity supplied by domestic suppliers and the quantity imported from Savimbiland when the tariff is in place? [5 marks]
 - f) Depict the equilibrium on the domestic demand and supply diagram of Mushalaland if the tariff of \$25/barrel is in place. The equilibrium should include the prevailing price, quantity supplied by domestic suppliers and quantity supplied by Savimbiland suppliers. [3 marks]
 - g) Compute the welfare effects of the tariff on all economic actors in both Mushalaland and Savimbiland. [8 marks]
3. A Zambian investor has a choice between investing K100 million in a South African financial asset or a similar asset in Zambia. The interest rate in Zambia (i_K) is 8.5% per year while the interest rate in South Africa (i_R) is 5% per year. Assume that the current exchange rate is 1.50 K/R and the expected exchange rate after one year is 1.35 K/R. *Please take note that K is for Zambian Kwacha and R is for South African Rand.*

Using the data provided:

- a) Show the currency that has more value in the current year. [1½ marks]
- b) Which currency is expected to appreciate after one year? [1½ marks]
- c) What will be the rate of return of investing in Zambia by the Zambia investor? [1½ marks]
- d) What will be the rate of return of investing in South Africa by the Zambia investor? [4 marks]
- e) In which country will you advise the investor to invest? Why? [1½ marks]

SECTION B

5. India, the second largest exporter of sugar in the world, recently announced that the country would restrict sugar exports to 10 million tons in 2022. In most years, the country exports more than 15 million tons. Using a clearly labelled partial equilibrium model diagram, explain in detail the potential price and welfare effects of this policy decision by India, assuming global sugar markets are competitive. **[15 marks]**

6. "It is always better for a country to have a trade surplus than a trade deficit." Do you agree or disagree with this statement? Using relevant concepts covered in class, explain why you agree or disagree with this statement. **[15 marks]**

7. "Overall, trade creation is always welfare improving to a small country." Do you agree or disagree with this statement? Using relevant concepts covered in class, explain why you agree or disagree with this statement. **[15 marks]**

----- END OF EXAM-----



THE UNIVERSITY OF ZAMBIA
UNIVERSITY EXAMINATIONS – NOVEMBER 2022
AGE 5162
AGRICULTURAL FINANCE

TIME: Three (3) Hours

Marks: 100

INSTRUCTIONS: ANSWER ALL QUESTIONS AND WRITE LEGIBLY

1. a) The study by the “Rural Finance Team” (1997) suggested comprehensive guiding principles necessary to transform the agricultural finance in Zambia:
 - i) State the characteristics the study suggested which a sustainable rural financial institution should have. **[5 marks]**
 - ii) State any five (5) other guiding policies suggested by the study for reorganizing and revitalizing the institutions in the rural financial market in Zambia. **[5 marks]**
- b) Describe and discuss briefly five challenges of agricultural finance in Zambia. **[10 marks]**

2. Briefly describe and discuss the following as optional sources of agricultural finance in Zambia:
 - a) Money Markets and Capital Markets. **[8 marks]**
 - b) Venture Capital and Angel Capital/Investor. **[6 marks]**
 - c) Leasing – also elaborating on the main types of leasing. **[6 marks]**

3. Financing agriculture is quite risky, the factor that must be taken into account in a farm business:
 - a) Differentiate between risk and uncertainty. **[2 marks]**
 - b) Differentiate between idiosyncratic risk (unsystematic risk) and systematic risk. **[2 marks]**
 - c) What are the key components/elements of risk? **[6 marks]**
 - d) Financial resources or efforts often cannot address all the risks at the same time. Describe briefly an approach that can be followed in the prioritization of risks in agriculture. **[6 marks]**
 - e) Insurance is aimed at reducing exposure to risk for the farmer. Briefly explain the nature of Weather-Index based Insurance (WII) and Multi-Peril Crop Insurance. (MPCI). **[4 marks]**

4. a) Is a budget different from a forecast? Explain your answer. **[2 marks]**
b) Highlight any three (3) uses of a budget **[3 marks]**
c) Briefly explain the following as they are applied to help in managing stock of an agribusiness:
- i) Economic Order Quantity (EOQ) model. **[5 marks]**
 - ii) Materials Requirement Planning (MRP) System. **[5 marks]**
 - iii) Just-in-time (JIT) Stock management. **[5 marks]**
5. a) Distinguish between the following terms: 'capital expenditure and revenue expenditure and mention the system(s) that management uses to control capital and revenue expenditure. **[6 Marks]**
b) Briefly state seven (7) practical ways of how you can prudently manage cash of an agribusiness. **[14 marks]**

END OF EXAMINATION



THE UNIVERSITY OF ZAMBIA
UNIVERSITY EXAMINATIONS – NOVEMBER 2022
AGE 5172

AGRICULTURAL POLICY ANALYSIS

TIME: Three (3) Hours

Marks: 100

INSTRUCTIONS: ANSWER ALL QUESTIONS AND WRITE LEGIBLY

1. a) Assuming conditions of perfect competitive market, use a supply, demand and equilibrium diagram to explain what would happen if Zambia was to embark on a policy of cheap food for the poor by setting a low price for maize and also explain some essentials namely consumer surplus and producer surplus that can be noted when considering the welfare analysis of market intervention. **[10 marks]**
b) In examining the geographical dimensions of markets, list five (5) examples of policy initiatives and comment on their importance in being used to remove constraints to trade and encouraging specialization and division of labour. **[10 marks]**
2. a) The market is said to fail when there is a technological externality or a non-market spillover. Explain and illustrate by use of a diagram and examples the economics of this type of failure as well as the correction of the externality. **[12 marks]**
b) It has been argued that the role of the state in the market economy is to provide “an appropriate institutional framework” or “enabling environment”. Explain briefly the areas of argument that have been developed in recent years indicating the changing attitudes towards the role of the state in the market economy. **[8 marks]**
3. a) The Policy Analysis Matrix (PAM) is an accounting framework which disaggregates the economics of a commodity system into its sources of private and social profitability. Describe briefly the steps to be followed in the construction of PAM. **[8 marks]**
b) Explain briefly the methodological issues to be considered by the policy analyst concerning the representative budget and social prices for domestic resources when applying the PAM. **[10 marks]**
4. a) A strategic grain reserve can be a particularly heavy fiscal drain if the staple food crop is procured at a pan-seasonal price and is a “switch crop”. Explain and illustrate by use of a diagram the possible loss and cost of grain reserve with trade when grain is procured at a pan-seasonal price and is a “switch crop”. **[10 marks]**
b) A distinction between national and individual food security is important in the formulation and implementation of policies to address the problems of food insecurity in Zambia. Discuss. **[6 marks]**
c) State three arguments that have been advanced in support of pan – territorial food crop pricing policy. **[4 marks]**

5. a) It has been argued that basic research is almost by definition a non-commercial activity since appropriability is expected to be low. Explain and illustrate by use of a diagram why this is so and how the suggested government tax/subsidy solution can lead to improved resource allocation. **[12 marks]**
- b) It has been recognized that substitutability and complementarity between public and private sectors is important in the promotion of research in the agricultural sector:
- (i) State four areas in which private sector incentives to conduct or fund research will be weak. **[4 marks]**
 - (ii) Outline three suggested examples of how participation of the private sector in agricultural research can be encouraged. **[4 marks]**

END OF EXAMINATION



THE UNIVERSITY OF ZAMBIA

UNIVERSITY SUPPLEMENTARY EXAMINATIONS – FEBRUARY 2022

AGE 5251

AGRICULTURAL PROJECT PLANNING AND APPRAISAL

TIME: 2 Hours

Marks: 60

INSTRUCTIONS: ANSWER ALL QUESTIONS AND WRITE LEGIBLY

1. The following investment outlay, operation and maintenance costs (cash outflows) as well as gross benefits (cash inflows) are given for a coffee production and processing project proposal:

Amounts in K' 000				
Year	Investment Outlay	Operation and maintenance	Production Cost	Gross Benefit
1	400	0	0	0
2	250	0	0	0
3	150	0	0	0
4	100	0	0	0
5	100	0	0	0
6	0	50	60	1110
7	0	50	70	1220
8	0	50	80	1330
9	0	50	90	1440
10	0	50	90	1440

- Compute the Net Benefit-Investment (N/K) ratio if the opportunity cost of capital is 30%. On the basis of the N/K you obtain, would you recommend the project as good investment? Explain why? **(6 marks)**
- Compute the Internal Rate of Return (IRR). On the basis of the IRR you obtain and given 30% as the opportunity cost of capital, would you recommend the project as good investment? Explain why? **(10 marks)**
- What advantages do discounted measures of project worth have over undiscounted measures of project worth? **(4 marks)**

2. The following information is given for a combine harvester to be imported into the country: the c.i.f. price is US\$105,000; the import levy is 5% of the c.i.f. price; the handling and clearing charges amount to K15,000 and the transportation to the project site is K6,000. The official exchange rate (OER) is K20.50 to US\$1 and a foreign exchange premium of 20% is estimated.

- Calculate the economic import parity value at the farm gate or project boundary using the conversion factor approach. **(8 marks)**
- Calculate the economic import parity value at the farm gate or project boundary using the shadow exchange rate approach. **(8 marks)**
- Why is it important to allow for a foreign exchange premium when calculating the economic import parity value? **(4 marks)**

3. The foreign exchange component and the domestic currency component of a layers' cages production project are as given in the following table:

Year	Foreign Exchange Component (US\$ '000)			Domestic Currency Component (K '000)	
	Value of Production	Investment Cost	Production Cost	Investment Cost	Production Cost
1	0	100	0	950	0
2	0	140	0	900	0
3	0	160	0	800	0
4	200	0	50	750	300
5	350	0	50	0	200
6	500	0	100	0	200
7	600	0	150	0	200
8	600	0	150	0	200
9	600	0	150	0	200
10	600	0	150	0	200

- a) If the opportunity cost of capital is 30%, compute the domestic resource cost (DRC). If the official exchange rate (OER) is K 18.50 to US\$1 and on the basis of the DRC you obtain, is the project favourable? Explain why? **(10 marks)**
- b) If there is a foreign exchange premium of 20%, what is the shadow exchange rate (SER)? In the light of the SER you obtain and on the basis of the DRC you obtained in a) above, would you say the project is favourable? Explain why? **(5 marks)**
- c) Explain why it is important to estimate the DRC and for what type of projects it should be applied? **(5 marks)**

END OF EXAMINATION

THE UNIVERSITY OF ZAMBIA
UNIVERSITY EXAMINATIONS –4th NOVEMBER 2022
AGE 5262
INTERMEDIATE FARM MANAGEMENT

TIME: 3 Hours

Marks: 100

INSTRUCTIONS: ANSWER ALL QUESTIONS AND WRITE LEGIBLY

1. a. Explain how a manager can hire agricultural labor under the following conditions: [10]
- i. When labour is limited
 - ii. When labour is variable but plentiful
 - iii. When labour is fixed but plentiful
- b. Briefly discuss any **ONE pair** of the following labor management concepts: [10]
- i. Employee termination; conflict management
 - ii. Employee evaluation; Disciplining
 - iii. Improving managerial capacity; leadership/management styles
 - iv. Motivating; communicating with employees
 - v. Occupational safety health act regulation; orienting new employees
2. Land control is a critical decision in production agriculture.
- a. Explain the advantages of controlling land through leasing. [10]
 - b. What are the key differences between owning land as *communal property* and *tenants- by the entirety*? [4]
 - c. Explain at least four (4) off- farm effects of production agriculture and how they can be incorporated in land use plans. [6]
3. A farmer is seeking combining services to help harvest his rice and sorghum and finds one medium combine harvester with a 400 cm rice cutter that can be operated at 10 km/hour with an efficiency of 85%. The same combine (with the same efficiency) can harvest sorghum using a 300 cm cutter at a speed of 13 km/ hour. Harvesting sorghum, takes 6 hours per day while harvesting rice takes 8 hours per day. Both fields of sorghum and rice are 400 hectares each.
- a. What is the effective field capacity when harvesting rice and sorghum separately? [4]
 - b. Suppose the farmer has 28 days to harvest both rice and sorghum, is this a good machine to purchase? (show your work) [10]
 - c. Assuming the combine meets the performance requirements and the farmer wants to estimate whether it is profitable to own it. He has provided the following from his records: K400,000 total debts; K1,000,000 total assets; 40% marginal tax rate; 10% long-run interest on debt; and 15% after tax return on equity. What is the discount rate he should use in estimating the profit using the net present value method? [6]

4. You are a loan officer at a farm credit bureau, and a farmer in question 3, comes to you to ask for a loan for him to purchase the combine that will cost him K950,000. He has provided the following cash flow information on his operation:

Cash receipts: K480,000

Cash expenses: K264,000

Taxes: K10,000

Living expenses: K60,000

- a. Does the farmer have the capacity to borrow the required amount of money using an equal total payment loan plan at 12 % annual interest to be repaid in 6 years? [4]
- b. Suppose the farmer also makes a one (1) year production loan amounting to K150,000 at 13% and you offer him a line of credit repayment plan as follows: [16]

January 1, 2022:	Loan is approved
February 1, 2022:	50% of the amount is transferred into the farm account
June 1, 2022:	Interest rate increases to 13.5%
July 1, 2022:	The remaining loan is transferred into the farm account
September 1, 2022:	K120,000 loan repayment
December 1, 2022:	K20,000 loan repayment
January 1, 2023:	The outstanding loan and interest cleared:

Prepare a loan schedule in a Table showing, date, amount borrowed, interest rate, amount repaid, interest paid, principal paid and outstanding principal balance.

5. a. Explain the difference between data and information and why this distinction is necessary in a management information system? [10]
- b. The following information is from a farmer's records (in ZWK) for 2022:

Cash expenses:	700,000	Cash farm income:	1, 250,000
Net accounts payable:	240,568	Unpaid labor:	30,800
Average asset value:	3, 800,000	Interest expense:	90,000
Depreciation expense:	97,000	Off farm income:	40,000
Net accounts receivable:	130,000	Family withdrawals:	70,000
Net inventories:	150,000	Net gain from tractor sale:	50,000
Net gain in the sale of breeding cows:	20,000	Total debt	1,200,000

Compute the following business analysis ratio:

- i. Net farm income from operations ratio [7]
- ii. Rate of return on equity [3]

UNIVERSITY OF ZAMBIA
SCHOOL OF AGRICULTURAL SCIENCES
DEPARTMENT OF AGRICULTURAL ECONOMICS AND EXTENSION

AGE 5272 – PROJECT MONITORING AND EVALUATION

SUPPLEMENTARY EXAM

MONDAY 14TH FEBRUARY 2022

DURATION: TWO HOURS

ANSWER ANY THREE QUESTIONS

NOTE: (a) Read the instructions again. (b) Write illegibly and clearly.

Question One (20 Marks)

- a. What is Monitoring? (2 marks)
- b. What is Evaluation? (2 marks)
- c. Highlight the key similarities and differences between 'Monitoring and Evaluation'. (8 marks)
- d. Briefly discuss the key evaluation activities conducted during project implementation? (8 marks)

Question Two (20 marks)

Citing appropriate examples, define the following terms. (The examples you cite **do not** necessary have to be based on the same project)

- a. Project (4 marks)
- b. Objectives (4 marks)
- c. Inputs (3 marks)
- d. Outputs (3 marks)
- e. Effects (3 marks)
- f. Impact (3 marks)

Question Three (20 Marks)

Write brief notes on the following;

- a. Mail survey/ Telephone interview (5marks)
- b. Triangulation (5marks)
- c. Focus group discussion (5marks)
- d. Beneficiary assessment (5marks)

Question Four (20 Marks)

- a. What is an 'Indicator'? Discuss the criteria for effective indicators. (10 marks)
- b. What is 'Participant Observation'? In your discussion of what 'Participant Observation' is, highlight the different stages of conducting one. (10 marks)

End of Exam



THE UNIVERSITY OF ZAMBIA
UNIVERSITY EXAMINATIONS – JUNE 2022
AGE 5451- ADVANCED ASPECTS OF RURAL SOCIOLOGY

TIME: 3 Hours

Marks: 100

INSTRUCTIONS: ANSWER QUESTION ONE WHICH IS COMPULSORY AND ANY OTHER THREE FOR A TOTAL OF FOUR QUESTIONS. EACH QUESTION IS WORTH 25%.

1. What do you understand **Sustainable Livelihoods** to mean? Identify and explain all the key components or issues that you should consider in analyzing rural livelihoods as proposed in the Sustainable Livelihoods (SL) Framework. Use a diagram to illustrate or help identify the components in the SL framework. **[25 Marks]**

2. Robert Chambers challenges development workers and academics' perception of rural poverty in his analysis of the many biases that impede outsiders' contact with rural poverty. **Identify and explain these biases.** Cite relevant examples to elaborate your answer. **[25 Marks]**

3. (a) Identify and **define the types of land tenure** or land ownership patterns in Zambia. **[10 Marks]**

(b) Identify and explain Brown's evidence and arguments on the impact or implications of the land reforms in Zambia under the 1995 Land Act. Cite relevant examples to elaborate your answer. **[15 Marks]**.

4. (a) In what ways does **poverty lead to environmental degradation**? In what way are the poor victims? Specifically, provide two examples of how the poor sometimes degrade the natural resources on which they depend. Why does this happen and what might be done to escape this trap? **[10 Marks]**

(b) How is **climate change expected to impact** countries in Asia and Africa? What policies in developed and developing countries may help address these problems? **[8 Marks]**

(c) How do farmers in developing countries **adapt** to climate change that they experience? **[7 Marks]**

5. What do you understand by the concept of **Green Revolution**? Discuss the **social and economic impacts** of the Green revolution. Who were the **primary beneficiaries** of the new agricultural technologies and **who were disadvantaged** by introduction of the "miracle rice" in the developing countries? Explain why this happened? **[25 Marks]**

6. (a) What is **food security**? Identify and explain in detail the factors that cause food insecurity **[10 Marks]**

(b) Explain and differentiate the terms **Acute, chronic and hidden food insecurity** **[7 Marks]**

(c) Women are more vulnerable to food insecurity than men. Discuss three reasons why this is the case. **[8 Marks]**

END OF EXAMINATION



THE UNIVERSITY OF ZAMBIA
UNIVERSITY EXAMINATIONS – NOVEMBER 2022

AGE 6322
APPLIED ECONOMETRICS

TIME: 3 Hours

Marks:60

INSTRUCTIONS:

1. This examination paper has **TWO** sections. **Section A** has **THREE** questions and **Section B** has **TWO** questions. Answer all questions in both sections and write legibly.
 2. Answer **Section A** in one answer booklet and **Section B** in a separate answer booklet.
 3. Label the section name on each answer booklet and ensure to tie them separately.
- Statistical tables are provided at the back of the exam.
-

SECTION A

1. [15 points] You have the results of a simple linear regression based on state-level data and the District of Columbia, a total of $N = 51$ observations.
 - a) The estimated error variance $\hat{\sigma}^2 = 2.04672$. What is the sum of the squared least squares residuals?
 - b) The estimated variance of b_2 is 0.00098. What is the standard error of b_2 ? What is the value of $\sum(x_i - \bar{x})^2$?
 - c) Suppose the dependent variable y_i is the state's mean income (in thousands of dollars) of males who are 18 years of age or older and x_i the percentage of males 18 years or older who are high school graduates. If $b_2 = 0.18$, interpret this result.
 - d) Suppose $\bar{x} = 69.139$ and $\bar{y} = 15.187$, what is the estimate of the intercept parameter?
 - e) Given the results in (b) and (d), what is $\sum x_i^2$?
 - f) For the state of Arkansas the value of $y_i = 12.274$ and the value of $x_i = 58.3$: Compute the least squares residual for Arkansas. (Hint: Use the information in parts (c) and (d).).
2. [15 points] Assuming you are using version 17 of Stata and are using "C:\Documents\AGE4322\Data" as the working directory, write do-file statements that perform the following:
 - a) Changes the directory to "C:\Documents\AGE4322\Data"
 - b) Opens and closes a new log file called "exam20"

- c) Opens a Stata dataset called “exam20.dta” and explores its contents and computes summary statistics
- d) Regresses y , a variable in exam20.dta, on x , another variable in the same file, using only the first 500 observations
- e) Displays any one of the postestimation scalars
- f) Saves the resultant dataset as exam20b.dta

SECTION B

3. [10 points] We are concerned that variability of yield may be dependent on other things causing heteroscedasticity in our regression model:

$$yield_i = \beta_1 + \beta_2 basalkg_i + \beta_3 topkg_i + \beta_4 seedkg_i + \beta_5 Eastern_i + e_i$$

$yield$ is maize yield in kg/ha, $basalkg$ is quantity of basal fertilizer applied, $topkg$ is the quantity of top dressing fertilizer applied in kilograms, $seedkg$ is the quantity of seed planted in kilograms and $eastern$ is a dummy variable equal to 1 if the farm is located in Eastern province and 0 otherwise.

- a. Suppose we suspect heteroscedasticity in our regression,
 - i. What OLS assumption(s) would be violated?
 - ii. What are the consequences of using OLS when heteroscedasticity is present?
- b. For each of the following suspected heteroscedasticity situations, mention a test you could use to detect it:
 - i. Unknown source
 - ii. Heteroscedasticity due to the variable $Basalkg$
 - iii. Heteroscedasticity due to the dummy variable $Eastern$

4. [20 points] Suppose you would like to measure the effect of education on wages of till operators in Zambia. You run an OLS regression in Stata and obtain the following results: The following is the regression output:

Source	SS	df	MS	Number of obs	=	1,200
Model	73521.2273	5	14704.2455	F(5, 1194)	=	86.02
Residual	204099.438	1,194	170.937553	Prob > F	=	0.0000
				R-squared	=	0.2648
				Adj R-squared	=	0.2617
Total	277620.665	1,199	231.543508	Root MSE	=	13.074

wage	Coef.	Std. Err.	t	P> t	[95% Conf. Interval]	
educ	2.464194	.1701896	14.48	0.000	2.13029	2.798098
exper	.5571012	.1026759	5.43	0.000	.355656	.7585465
expersquare	-.0074111	.00205	-3.62	0.000	-.0114332	-.0033891
female	-9.63537	3.961146	-2.43	0.015	-17.40695	-1.863788
femedu	.3715973	.2712284	1.37	0.171	-.16054	.9037346
_cons	-17.17327	2.635844	-6.52	0.000	-22.34467	-12.00187

where *wage* is the wage, *educ* is the highest education level attained in years, *exper* is work experience, *exper2* the square of experience, *female* is a dummy variable equal to 1 if female and 0 if male, *femeduc* is an interaction variable of female and education.

- Write the econometric model for this regression output.
- Write the econometric model for observations whose value of the variable *female*=0
- Write the econometric model for observations whose value of the variable *female*=1.
- What is the interpretation of the OLS coefficient for *female*?
- Comment on why the researcher may have included the interaction between female and education, *femeduc* in this regression.
- Given the following output,

Source	SS	df	MS	Number of obs	=	1,200
Model	67786.098	3	22595.366	F(3, 1196)	=	128.79
Residual	209834.568	1,196	175.446963	Prob > F	=	0.0000
				R-squared	=	0.2442
				Adj R-squared	=	0.2423
Total	277620.665	1,199	231.543508	Root MSE	=	13.246

wage	Coef.	Std. Err.	t	P> t	[95% Conf. Interval]
educ	2.517771	.1364395	18.45	0.000	2.250084 2.785459
exper	.5455117	.1039436	5.25	0.000	.3415796 .7494439
expersquare	-.0071881	.0020759	-3.46	0.001	-.0112608 -.0031153
_cons	-19.6777	2.270441	-8.67	0.000	-24.13219 -15.22321

test the hypothesis that *female* and *femeduc* are jointly important in explaining wages at the 95% confidence level. Ensure you clearly state the full steps of your hypothesis test.

----- END OF EXAM-----

Table 4 Normal Curve Areas
Standard normal probability in right-hand tail
(for negative values of z, areas are found by symmetry)



z	Second decimal place of z									
	.00	.01	.02	.03	.04	.05	.06	.07	.08	.09
0.0	.5000	.4960	.4920	.4880	.4840	.4801	.4761	.4721	.4681	.4641
0.1	.4602	.4562	.4522	.4483	.4443	.4404	.4364	.4325	.4286	.4247
0.2	.4207	.4168	.4129	.4090	.4052	.4013	.3974	.3936	.3897	.3859
0.3	.3821	.3783	.3745	.3707	.3669	.3632	.3594	.3557	.3520	.3483
0.4	.3446	.3409	.3372	.3336	.3300	.3264	.3228	.3192	.3156	.3121
0.5	.3085	.3050	.3015	.2981	.2946	.2912	.2877	.2843	.2810	.2776
0.6	.2743	.2709	.2676	.2643	.2611	.2578	.2546	.2514	.2483	.2451
0.7	.2420	.2389	.2358	.2327	.2296	.2266	.2236	.2206	.2177	.2148
0.8	.2119	.2090	.2061	.2033	.2005	.1977	.1949	.1922	.1894	.1867
0.9	.1841	.1814	.1788	.1762	.1736	.1711	.1685	.1660	.1635	.1611
1.0	.1587	.1562	.1539	.1515	.1492	.1469	.1446	.1423	.1401	.1379
1.1	.1357	.1335	.1314	.1292	.1271	.1251	.1230	.1210	.1190	.1170
1.2	.1151	.1131	.1112	.1093	.1075	.1056	.1038	.1020	.1003	.0985
1.3	.0968	.0951	.0934	.0918	.0901	.0885	.0869	.0853	.0838	.0823
1.4	.0808	.0793	.0778	.0764	.0749	.0735	.0722	.0708	.0694	.0681
1.5	.0668	.0655	.0643	.0630	.0618	.0606	.0594	.0582	.0571	.0559
1.6	.0548	.0537	.0526	.0516	.0505	.0495	.0485	.0475	.0465	.0455
1.7	.0446	.0436	.0427	.0418	.0409	.0401	.0392	.0384	.0375	.0367
1.8	.0359	.0352	.0344	.0336	.0329	.0322	.0314	.0307	.0301	.0294
1.9	.0287	.0281	.0274	.0268	.0262	.0256	.0250	.0244	.0239	.0233
2.0	.0228	.0222	.0217	.0212	.0207	.0202	.0197	.0192	.0188	.0183
2.1	.0179	.0174	.0170	.0166	.0162	.0158	.0154	.0150	.0146	.0143
2.2	.0139	.0136	.0132	.0129	.0125	.0122	.0119	.0116	.0113	.0110
2.3	.0107	.0104	.0102	.0099	.0096	.0094	.0091	.0089	.0087	.0084
2.4	.0082	.0080	.0078	.0075	.0073	.0071	.0069	.0068	.0066	.0064
2.5	.0062	.0060	.0059	.0057	.0055	.0054	.0052	.0051	.0049	.0048
2.6	.0047	.0045	.0044	.0043	.0041	.0040	.0039	.0038	.0037	.0036
2.7	.0035	.0034	.0033	.0032	.0031	.0030	.0029	.0028	.0027	.0026
2.8	.0026	.0025	.0024	.0023	.0023	.0022	.0021	.0021	.0020	.0019
2.9	.0019	.0018	.0017	.0017	.0016	.0016	.0015	.0015	.0014	.0014
3.0	.0013									
3.5	.000233									
4.0	.0000317									
4.5	.00000340									
5.0	.000000287									

From R. E. Walpole: *Introduction to Statistics* (New York: Macmillan, 1968).

Table 5 Percentage Points of the t Distributions

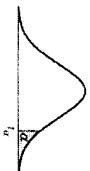

df	t _{0.99}	t _{0.95}	t _{0.90}	t _{0.85}	t _{0.80}	t _{0.75}	t _{0.70}	t _{0.65}	t _{0.60}	t _{0.55}	t _{0.50}	t _{0.45}	t _{0.40}	t _{0.35}	t _{0.30}	t _{0.25}	t _{0.20}	t _{0.15}	t _{0.10}	t _{0.05}	t _{0.025}	t _{0.01}	t _{0.005}		
1	3.078	6.314	12.706	31.821	63.657	99.25	137.47	161.27	179.58	194.48	200.00	205.95	211.99	218.01	224.08	230.29	236.64	243.14	249.76	256.69	263.91	271.33	279.09	287.10	
2	1.886	2.920	4.303	6.965	9.925	12.706	15.086	16.812	18.023	18.852	19.427	19.850	20.224	20.558	20.851	21.111	21.345	21.551	21.728	21.881	22.013	22.127	22.226	22.313	22.389
3	1.638	2.353	3.182	4.541	5.841	7.159	8.143	8.845	9.388	9.801	10.117	10.351	10.531	10.676	10.794	10.889	10.966	11.028	11.078	11.118	11.149	11.173	11.191	11.204	11.213
4	1.533	2.132	2.776	3.747	4.604	5.408	6.128	6.693	7.127	7.463	7.721	7.927	8.091	8.221	8.328	8.417	8.491	8.552	8.601	8.640	8.670	8.693	8.710	8.724	8.735
5	1.476	2.015	2.571	3.365	4.032	4.726	5.301	5.786	6.183	6.521	6.807	7.047	7.247	7.411	7.547	7.667	7.771	7.861	7.938	8.006	8.066	8.118	8.163	8.201	8.232
6	1.440	1.943	2.447	3.143	3.707	4.314	4.821	5.247	5.601	5.901	6.161	6.381	6.561	6.711	6.841	6.951	7.046	7.127	7.196	7.255	7.306	7.351	7.390	7.424	7.453
7	1.415	1.895	2.365	2.998	3.499	4.032	4.521	4.921	5.281	5.591	5.851	6.071	6.251	6.401	6.531	6.641	6.731	6.801	6.861	6.911	6.951	6.986	7.016	7.041	7.061
8	1.397	1.860	2.306	2.896	3.355	3.855	4.314	4.681	5.041	5.351	5.611	5.831	6.011	6.161	6.291	6.401	6.491	6.561	6.611	6.651	6.686	6.716	6.741	6.761	6.776
9	1.383	1.833	2.262	2.821	3.250	3.707	4.143	4.501	4.851	5.161	5.421	5.641	5.821	5.971	6.101	6.211	6.301	6.371	6.421	6.461	6.491	6.516	6.536	6.551	6.561
10	1.372	1.812	2.228	2.764	3.169	3.619	4.032	4.381	4.721	5.031	5.291	5.511	5.691	5.841	5.971	6.081	6.171	6.241	6.291	6.331	6.361	6.386	6.406	6.421	6.431
11	1.363	1.796	2.201	2.718	3.106	3.501	3.881	4.221	4.551	4.861	5.121	5.341	5.521	5.671	5.801	5.911	6.001	6.071	6.121	6.161	6.191	6.216	6.236	6.251	6.261
12	1.356	1.782	2.179	2.681	3.055	3.451	3.811	4.141	4.471	4.781	5.041	5.261	5.441	5.591	5.721	5.831	5.921	6.001	6.051	6.091	6.121	6.146	6.166	6.181	6.191
13	1.350	1.771	2.160	2.650	3.012	3.414	3.771	4.101	4.431	4.741	5.001	5.221	5.401	5.551	5.681	5.791	5.881	5.951	6.001	6.041	6.071	6.096	6.116	6.131	6.141
14	1.345	1.761	2.145	2.624	2.977	3.379	3.731	4.061	4.391	4.701	4.961	5.181	5.361	5.511	5.641	5.751	5.841	5.911	5.961	6.001	6.031	6.056	6.076	6.091	6.101
15	1.341	1.753	2.131	2.602	2.947	3.349	3.701	4.031	4.361	4.671	4.931	5.151	5.331	5.481	5.611	5.721	5.811	5.881	5.931	5.971	6.001	6.026	6.046	6.061	6.071
16	1.337	1.746	2.120	2.583	2.921	3.323	3.671	3.991	4.321	4.631	4.891	5.111	5.291	5.441	5.571	5.681	5.771	5.841	5.891	5.931	5.961	5.986	6.006	6.021	6.031
17	1.333	1.740	2.110	2.567	2.898	3.299	3.641	3.961	4.291	4.601	4.861	5.081	5.261	5.411	5.541	5.651	5.741	5.811	5.861	5.901	5.931	5.956	5.976	5.991	6.001
18	1.330	1.734	2.101	2.552	2.878	3.279	3.621	3.941	4.271	4.581	4.841	5.061	5.241	5.391	5.521	5.631	5.721	5.791	5.841	5.881	5.911	5.936	5.956	5.971	5.981
19	1.328	1.729	2.093	2.539	2.861	3.261	3.601	3.921	4.251	4.561	4.821	5.041	5.221	5.371	5.501	5.611	5.701	5.771	5.821	5.861	5.891	5.916	5.936	5.951	5.961
20	1.325	1.725	2.086	2.528	2.845	3.245	3.581	3.901	4.231	4.541	4.801	5.021	5.201	5.351	5.481	5.591	5.681	5.751	5.801	5.841	5.871	5.896	5.916	5.931	5.941
21	1.323	1.721	2.080	2.518	2.831	3.231	3.561	3.881	4.211	4.521	4.781	5.001	5.181	5.331	5.461	5.571	5.661	5.731	5.781	5.821	5.851	5.876	5.896	5.911	5.921
22	1.321	1.717	2.074	2.508	2.819	3.221	3.551	3.871	4.201	4.511	4.771	4.991	5.171	5.321	5.451	5.561	5.651	5.721	5.771	5.811	5.841	5.866	5.886	5.901	5.911
23	1.319	1.714	2.069	2.500	2.807	3.211	3.541	3.861	4.191	4.501	4.761	4.981	5.161	5.311	5.441	5.551	5.641	5.711	5.761	5.801	5.831	5.856	5.876	5.891	5.901
24	1.318	1.711	2.064	2.492	2.797	3.201	3.531	3.851	4.181	4.491	4.751	4.971	5.151	5.301	5.431	5.541	5.631	5.701	5.751	5.791	5.821	5.846	5.866	5.881	5.891
25	1.316	1.708	2.060	2.485	2.787	3.191	3.521	3.841	4.171	4.481	4.741	4.961	5.141	5.291	5.421	5.531	5.621	5.691	5.741	5.781	5.811	5.836	5.856	5.871	5.881
26	1.315	1.706	2.056	2.479	2.779	3.181	3.511	3.831	4.161	4.471	4.731	4.951	5.131	5.281	5.411	5.521	5.611	5.681	5.731	5.771	5.801	5.826	5.846	5.861	5.871
27	1.314	1.703	2.052	2.473	2.771	3.171	3.501	3.821	4.151	4.461	4.721	4.941	5.121	5.271	5.401	5.511	5.601	5.671	5.721	5.761	5.791	5.816	5.836	5.851	5.861
28	1.313	1.701	2.048	2.467	2.763	3.161	3.491	3.811	4.141	4.451	4.711	4.931	5.111	5.261	5.391	5.501	5.591	5.661	5.711	5.751	5.781	5.806	5.826	5.841	5.851
29	1.311	1.699	2.045	2.462	2.756	3.151	3.481	3.801	4.131	4.441	4.701	4.921	5.101	5.251	5.381	5.491	5.581	5.651	5.701	5.741	5.771	5.796	5.816	5.831	5.841
inf.	1.282	1.645	1.960	2.326	2.576	3.000	3.331	3.651	3.981	4.301	4.621	4.941	5.161	5.311	5.441	5.551	5.641	5.711	5.761	5.801	5.831	5.856	5.876	5.891	5.901

From "Table of Percentage Points of the *t*-Distribution," Computed by Maxine Mermigan, *Biometrika*, Vol. 32 (1941), p. 300.

Table 6 Percentage Points of the χ^2 Distributions

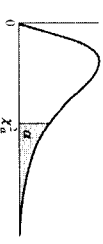

df	$\chi^2_{0.995}$	$\chi^2_{0.990}$	$\chi^2_{0.975}$	$\chi^2_{0.950}$	$\chi^2_{0.900}$
1	0.0000393	0.0001571	0.0009821	0.0039321	0.0157908
2	0.0100251	0.0201007	0.0506356	0.1025872	0.2101730
3	0.0717212	0.114832	0.215795	0.351846	0.584375
4	0.206990	0.297110	0.484419	0.710721	1.065633
5	0.411740	0.554300	0.831211	1.145476	1.61031
6	0.675727	0.872085	1.237347	1.653539	2.20413
7	0.989265	1.239043	1.68987	2.16735	2.83311
8	1.34419	1.646482	2.17973	2.73264	3.48954
9	1.734926	2.087912	2.70039	3.32511	4.16816
10	2.15585	2.55821	3.24697	3.94030	4.86518
11	2.60321	3.05347	3.81575	4.57481	5.57779
12	3.07382	3.57056	4.40379	5.22603	6.30380
13	3.56503	4.10691	5.00874	5.89186	7.04150
14	4.07468	4.66043	5.62872	6.57063	7.78953
15	4.60094	5.22935	6.26214	7.26094	8.54675
16	5.14224	5.81221	6.90766	7.96164	9.31223
17	5.69724	6.40776	7.56418	8.67176	10.0832
18	6.26481	7.01491	8.23075	9.39046	10.8649
19	6.84398	7.63273	8.90655	10.1170	11.6509
20	7.43386	8.26040	9.59083	10.8508	12.4426
21	8.03366	8.89720	10.28293	11.5913	13.2396
22	8.64272	9.54249	10.9823	12.3380	14.0415
23	9.26042	10.19567	11.6885	13.0905	14.8479
24	9.88623	10.8564	12.4011	13.8484	15.6587
25	10.5197	11.5240	13.1197	14.6114	16.4734
26	11.1603	12.1981	13.8439	15.3791	17.2919
27	11.8076	12.8786	14.5733	16.1513	18.1138
28	12.4613	13.5648	15.3079	16.9279	18.9392
29	13.1211	14.2565	16.0471	17.7083	19.7677
30	13.7867	14.9535	16.7908	18.4926	20.5992
40	20.7065	22.1643	24.4331	26.5093	29.0505
50	27.9907	29.7067	32.3574	34.7642	37.6886
60	35.5346	37.4848	40.4817	43.1879	46.4589
70	43.2752	45.4418	48.7576	51.7393	55.3290
80	51.1720	53.5400	57.1532	60.3915	64.2778
90	59.1963	61.7541	65.6466	69.1260	73.2912
100	67.3276	70.0648	74.2219	77.9295	82.3581

Table 6 (Continued)

$\chi^2_{0.950}$	$\chi^2_{0.900}$	$\chi^2_{0.850}$	$\chi^2_{0.800}$	$\chi^2_{0.750}$	$\chi^2_{0.700}$	df
2.70554	3.84146	5.02389	6.63490	7.87944		1
4.60517	5.99147	7.37776	9.21024	10.5966		2
6.25139	7.81473	9.34840	11.3449	12.8381		3
7.77944	9.48773	11.1433	13.2767	14.8602		4
9.23635	11.0705	12.8325	15.0863	16.7496		5
10.6446	12.5916	14.4494	16.8119	18.5476		6
12.0170	14.0671	16.0128	18.4753	20.2777		7
13.3616	15.5073	17.5346	20.0902	21.9950		8
14.6837	16.9190	19.0228	21.6660	23.5893		9
15.9871	18.3070	20.4831	23.2093	25.1882		10
17.2750	19.6751	21.9200	24.7250	26.7576		11
18.5494	21.0261	23.3367	26.2170	28.2995		12
19.8119	22.3621	24.7356	27.6883	29.8194		13
21.0642	23.6848	26.1190	29.1413	31.3193		14
22.3072	24.9958	27.4884	30.5779	32.8013		15
23.5418	26.2962	28.8454	31.9999	34.2672		16
24.7690	27.5871	30.1910	33.4087	35.7185		17
25.9894	28.8693	31.5264	34.8053	37.1564		18
27.2036	30.1435	32.8323	36.1908	38.5822		19
28.4120	31.4104	34.1696	37.5662	39.9968		20
29.6151	32.6705	35.4789	38.9321	41.4010		21
30.8133	33.9244	36.7807	40.2894	42.7956		22
32.0069	35.1725	38.0757	41.6384	44.1813		23
33.1963	36.4151	39.3641	42.9798	45.5585		24
34.3816	37.6525	40.6465	44.3141	46.9278		25
35.5631	38.8852	41.9232	45.6417	48.2899		26
36.7412	40.1133	43.1944	46.9650	49.6449		27
37.9159	41.3372	44.4607	48.2782	50.9933		28
39.0875	42.5569	45.7222	49.5879	52.3356		29
40.2560	43.7729	46.9792	50.8922	53.6720		30
51.8050	55.7585	59.3417	63.6907	66.7639		40
63.1671	67.5048	71.4202	76.1508	79.4900		50
74.3970	79.0819	83.2976	88.3794	91.9517		60
85.5271	90.5312	95.0231	100.425	104.215		70
96.5782	101.879	106.629	112.329	116.321		80
107.565	113.145	118.136	124.116	128.299		90
118.498	124.342	129.561	135.807	140.169		100

From "Tables of the Percentage Points of the χ^2 Distribution," *Biometrika*, Vol. 32 (1944), pp. 188-189, by Catherine M. Thompson.

Table 7 (Continued)

Denominator df	F_{α}									
	α	1	2	3	4	5	6	7	8	9
8	.100	3.46	3.11	2.92	2.81	2.73	2.67	2.62	2.59	2.56
	.050	5.32	4.46	4.07	3.84	3.69	3.58	3.50	3.44	3.39
	.025	7.57	6.06	5.42	5.05	4.82	4.65	4.53	4.43	4.36
	.010	11.26	8.65	7.59	7.01	6.63	6.37	6.18	6.03	5.91
	.005	14.69	11.04	9.60	8.81	8.30	7.95	7.69	7.50	7.34
9	.100	3.36	3.01	2.81	2.69	2.61	2.55	2.51	2.47	2.44
	.050	5.12	4.26	3.86	3.63	3.48	3.37	3.29	3.23	3.18
	.025	7.21	5.71	5.08	4.72	4.48	4.32	4.20	4.10	4.03
	.010	10.56	8.02	6.99	6.42	6.06	5.80	5.61	5.47	5.35
	.005	13.61	10.11	8.72	7.96	7.47	7.13	6.88	6.69	6.54
10	.100	3.29	2.92	2.73	2.61	2.52	2.46	2.41	2.38	2.35
	.050	4.96	4.10	3.71	3.48	3.33	3.22	3.14	3.07	3.02
	.025	6.94	5.46	4.83	4.47	4.24	4.07	3.95	3.85	3.78
	.010	10.04	7.56	6.55	5.99	5.64	5.39	5.20	5.06	4.94
	.005	12.83	9.43	8.08	7.34	6.87	6.54	6.30	6.12	5.97
11	.100	3.23	2.86	2.66	2.54	2.45	2.39	2.34	2.30	2.27
	.050	4.84	3.98	3.59	3.36	3.20	3.09	3.01	2.95	2.90
	.025	6.72	5.26	4.63	4.28	4.04	3.88	3.76	3.66	3.59
	.010	9.65	7.21	6.22	5.67	5.32	5.07	4.89	4.74	4.63
	.005	12.23	8.91	7.60	6.88	6.42	6.10	5.86	5.68	5.54
12	.100	3.18	2.81	2.61	2.48	2.39	2.33	2.28	2.24	2.21
	.050	4.75	3.89	3.49	3.26	3.11	3.00	2.91	2.85	2.80
	.025	6.55	5.10	4.47	4.12	3.89	3.73	3.61	3.51	3.44
	.010	9.33	6.93	5.95	5.41	5.06	4.82	4.64	4.50	4.39
	.005	11.75	8.51	7.23	6.52	6.07	5.76	5.52	5.35	5.20
13	.100	3.14	2.76	2.56	2.43	2.35	2.28	2.23	2.20	2.16
	.050	4.67	3.81	3.41	3.18	3.03	2.92	2.83	2.77	2.71
	.025	6.41	4.97	4.35	4.00	3.77	3.60	3.48	3.39	3.31
	.010	9.07	6.70	5.74	5.21	4.86	4.62	4.44	4.30	4.19
	.005	11.37	8.19	6.93	6.23	5.79	5.48	5.25	5.08	4.94
14	.100	3.10	2.73	2.52	2.39	2.31	2.24	2.19	2.15	2.12
	.050	4.60	3.74	3.34	3.11	2.96	2.85	2.76	2.70	2.65
	.025	6.30	4.86	4.24	3.89	3.66	3.50	3.38	3.29	3.21
	.010	8.86	6.51	5.56	5.04	4.69	4.46	4.28	4.14	4.03
	.005	11.06	7.92	6.68	6.00	5.56	5.26	5.03	4.86	4.72

Table 7 (Continued)

Denominator df	F_{α}												
	10	12	15	20	24	30	40	60	120	∞	α	df	
8	2.54	2.50	2.46	2.42	2.40	2.38	2.36	2.34	2.32	2.29	.100	10	
	3.35	3.28	3.22	3.15	3.12	3.08	3.04	3.01	2.97	2.93	.050	8	
	4.30	4.20	4.10	4.00	3.95	3.89	3.84	3.78	3.73	3.67	.025	8	
	5.81	5.67	5.52	5.36	5.28	5.20	5.12	5.03	4.95	4.86	.010	8	
	7.21	7.01	6.81	6.61	6.50	6.40	6.29	6.18	6.06	5.95	.005	8	
9	2.42	2.38	2.34	2.30	2.28	2.25	2.23	2.21	2.18	2.16	.100	9	
	3.14	3.07	3.01	2.94	2.90	2.86	2.83	2.79	2.75	2.71	.050	9	
	3.96	3.87	3.77	3.67	3.61	3.56	3.51	3.45	3.39	3.33	.025	9	
	5.26	5.11	4.96	4.81	4.73	4.65	4.57	4.48	4.40	4.31	.010	9	
	6.42	6.23	6.03	5.83	5.73	5.62	5.52	5.41	5.30	5.19	.005	9	
10	2.32	2.28	2.24	2.20	2.18	2.16	2.13	2.11	2.08	2.06	.100	10	
	2.98	2.91	2.85	2.77	2.74	2.70	2.66	2.62	2.58	2.54	.050	10	
	3.72	3.62	3.52	3.42	3.37	3.31	3.26	3.20	3.14	3.08	.025	10	
	4.85	4.71	4.56	4.41	4.33	4.25	4.17	4.08	4.00	3.91	.010	10	
	5.85	5.66	5.47	5.27	5.17	5.07	4.97	4.86	4.75	4.64	.005	10	
11	2.25	2.21	2.17	2.12	2.10	2.08	2.05	2.03	2.00	1.97	.100	11	
	2.85	2.79	2.72	2.65	2.61	2.57	2.53	2.49	2.45	2.40	.050	11	
	3.53	3.43	3.33	3.23	3.17	3.12	3.06	3.00	2.94	2.88	.025	11	
	4.54	4.40	4.25	4.10	4.02	3.94	3.86	3.78	3.69	3.60	.010	11	
	5.42	5.24	5.05	4.86	4.76	4.65	4.55	4.44	4.34	4.23	.005	11	
12	2.19	2.15	2.10	2.06	2.04	2.01	1.99	1.96	1.93	1.90	.100	12	
	2.75	2.69	2.62	2.54	2.51	2.47	2.43	2.38	2.34	2.30	.050	12	
	3.37	3.28	3.18	3.07	3.02	2.96	2.91	2.85	2.79	2.72	.025	12	
	4.30	4.16	4.01	3.86	3.78	3.69	3.62	3.54	3.45	3.36	.010	12	
	5.09	4.91	4.72	4.53	4.43	4.33	4.23	4.12	4.01	3.90	.005	12	
13	2.14	2.10	2.05	2.01	1.98	1.96	1.93	1.90	1.88	1.85	.100	13	
	2.67	2.60	2.53	2.46	2.42	2.38	2.34	2.30	2.25	2.21	.050	13	
	3.25	3.15	3.05	2.95	2.89	2.84	2.78	2.72	2.66	2.60	.025	13	
	4.10	3.96	3.82	3.66	3.59	3.51	3.43	3.34	3.25	3.17	.010	13	
	4.82	4.64	4.46	4.27	4.17	4.07	3.97	3.87	3.76	3.65	.005	13	
14	2.10	2.05	2.01	1.96	1.94	1.91	1.89	1.86	1.83	1.80	.100	14	
	2.60	2.53	2.46	2.39	2.35	2.31	2.27	2.22	2.18	2.13	.050	14	
	3.15	3.05	2.95	2.84	2.79	2.73	2.67	2.61	2.55	2.49	.025	14	
	3.94	3.80	3.66	3.51	3.43	3.35	3.27	3.18	3.09	3.00	.010	14	
	4.60	4.43	4.25	4.06	3.96	3.86	3.76	3.66	3.55	3.44	.005	14	

Table 7 Percentage Points of the F Distributions

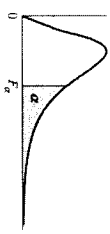

Denominator df	Numerator df									Numerator df													df
	1	2	3	4	5	6	7	8	9	10	12	15	20	24	30	40	60	120	∞				
1	100	39.86	49.50	53.59	55.83	57.24	58.20	58.91	59.44	59.86	60.19	60.71	61.22	61.74	62.00	62.26	62.53	62.79	63.06	63.33	100	1	
	.050	16.14	19.95	21.57	22.46	23.02	23.40	23.68	23.89	24.05	24.19	24.39	24.59	24.80	24.91	25.01	25.11	25.22	25.33	25.43	.050	2	
	.025	647.8	799.5	864.2	899.6	921.8	937.1	948.2	956.7	963.3	968.6	971.6	975.7	979.9	984.1	988.3	992.5	996.7	999.9	1000	.025	3	
	.010	4052	4999.5	5403	5625	5764	5859	5928	5982	6022	6056	6106	6157	6209	6255	6296	6333	6366	6395	6422	.010	4	
	.005	16211	20000	21615	22900	23056	23437	23715	23925	24091	24224	24426	24630	24836	24940	25044	25148	25253	25359	25465	.005	5	
2	100	8.53	9.00	9.16	9.24	9.29	9.33	9.35	9.37	9.38	9.39	9.41	9.42	9.44	9.45	9.46	9.47	9.47	9.48	9.49	100	2	
	.050	18.51	19.00	19.16	19.25	19.30	19.33	19.35	19.37	19.38	19.40	19.41	19.43	19.45	19.45	19.45	19.47	19.48	19.49	19.50	.050	3	
	.025	38.51	39.00	39.17	39.25	39.30	39.33	39.36	39.37	39.39	39.40	39.41	39.43	39.45	39.46	39.46	39.47	39.48	39.49	39.50	.025	4	
	.010	98.50	99.00	99.17	99.25	99.30	99.33	99.36	99.37	99.39	99.40	99.42	99.43	99.45	99.46	99.47	99.48	99.49	99.50	99.50	.010	5	
	.005	198.5	199.0	199.2	199.2	199.3	199.3	199.4	199.4	199.4	199.4	199.4	199.4	199.4	199.5	199.5	199.5	199.5	199.5	199.5	.005	6	
3	100	5.54	5.46	5.39	5.34	5.31	5.28	5.27	5.25	5.24	5.23	5.22	5.22	5.20	5.18	5.17	5.16	5.15	5.14	5.13	100	3	
	.050	10.13	9.55	9.28	9.12	9.01	8.94	8.89	8.85	8.81	8.79	8.74	8.70	8.66	8.64	8.62	8.59	8.57	8.55	8.53	.050	4	
	.025	17.44	16.04	15.44	15.10	14.88	14.73	14.62	14.54	14.47	14.42	14.34	14.25	14.17	14.12	14.08	14.04	13.99	13.95	13.90	.025	5	
	.010	34.12	30.82	29.46	28.71	28.24	27.91	27.67	27.49	27.35	27.23	27.05	26.87	26.69	26.60	26.50	26.41	26.32	26.22	26.13	.010	6	
	.005	55.55	49.80	47.47	46.19	45.39	44.84	44.43	44.13	43.88	43.69	43.39	43.08	42.78	42.62	42.47	42.31	42.15	41.99	41.83	.005	7	
4	100	4.54	4.32	4.19	4.11	4.05	4.01	3.98	3.95	3.94	3.92	3.90	3.87	3.84	3.83	3.82	3.80	3.79	3.78	3.76	100	4	
	.050	7.71	6.94	6.59	6.39	6.26	6.16	6.09	6.04	6.00	5.96	5.91	5.86	5.80	5.77	5.75	5.72	5.69	5.66	5.63	.050	5	
	.025	12.22	10.65	9.98	9.60	9.36	9.20	9.07	8.98	8.90	8.84	8.75	8.66	8.56	8.51	8.46	8.41	8.36	8.31	8.26	.025	6	
	.010	21.20	18.00	16.69	15.98	15.52	15.21	14.98	14.80	14.66	14.55	14.37	14.20	14.02	13.93	13.84	13.75	13.65	13.56	13.46	.010	7	
	.005	31.33	26.28	24.26	23.15	22.46	21.97	21.62	21.35	21.14	20.97	20.70	20.44	20.17	20.03	19.89	19.75	19.61	19.47	19.32	.005	8	
5	100	4.06	3.78	3.62	3.52	3.45	3.40	3.37	3.34	3.32	3.30	3.27	3.24	3.21	3.19	3.17	3.16	3.14	3.12	3.10	100	5	
	.050	6.61	5.79	5.41	5.19	5.05	4.95	4.88	4.82	4.77	4.74	4.68	4.62	4.56	4.53	4.50	4.46	4.43	4.40	4.36	.050	6	
	.025	10.01	8.43	7.76	7.37	7.15	6.98	6.85	6.76	6.68	6.62	6.52	6.43	6.33	6.28	6.23	6.18	6.12	6.07	6.02	.025	7	
	.010	16.26	13.27	12.06	11.39	10.97	10.67	10.46	10.29	10.16	10.05	9.89	9.72	9.55	9.47	9.38	9.30	9.23	9.11	9.02	.010	8	
	.005	22.78	18.31	16.53	15.56	14.94	14.51	14.20	13.96	13.77	13.62	13.38	13.15	12.90	12.78	12.66	12.53	12.40	12.27	12.14	.005	9	
6	100	3.78	3.46	3.29	3.18	3.11	3.05	3.01	2.98	2.96	2.94	2.90	2.87	2.84	2.82	2.80	2.78	2.76	2.74	2.72	100	6	
	.050	5.99	5.14	4.76	4.53	4.39	4.28	4.21	4.15	4.10	4.06	4.00	3.94	3.87	3.84	3.81	3.77	3.74	3.70	3.67	.050	7	
	.025	8.81	7.26	6.60	6.23	5.99	5.82	5.70	5.60	5.52	5.46	5.37	5.27	5.17	5.12	5.07	5.01	4.96	4.90	4.85	.025	8	
	.010	13.75	10.92	9.78	9.15	8.75	8.47	8.26	8.10	7.98	7.87	7.72	7.56	7.40	7.31	7.23	7.14	7.06	6.97	6.88	.010	9	
	.005	18.63	14.54	12.92	12.03	11.46	11.07	10.79	10.57	10.39	10.25	10.03	9.81	9.59	9.47	9.36	9.24	9.12	9.00	8.88	.005	10	
7	100	3.59	3.26	3.07	2.96	2.88	2.83	2.78	2.75	2.72	2.70	2.67	2.63	2.59	2.58	2.56	2.54	2.51	2.49	2.47	100	7	
	.050	5.59	4.74	4.35	4.12	3.97	3.87	3.79	3.73	3.68	3.64	3.57	3.51	3.44	3.41	3.38	3.34	3.30	3.27	3.23	.050	8	
	.025	8.07	6.54	5.89	5.52	5.29	5.12	4.99	4.90	4.82	4.76	4.67	4.57	4.47	4.42	4.36	4.31	4.25	4.20	4.14	.025	9	
	.010	12.25	9.55	8.45	7.85	7.46	7.19	6.99	6.84	6.72	6.62	6.47	6.31	6.16	6.07	6.00	5.91	5.82	5.74	5.65	.010	10	
	.005	16.24	12.40	10.88	10.05	9.52	9.16	8.89	8.68	8.51	8.38	8.18	7.97	7.75	7.65	7.53	7.42	7.31	7.19	7.08	.005	11	

Table 7 (Continued)

Table 7 (Continued)

Denominator df	F_{α}									
	α	1	2	3	4	5	6	7	8	9
22	.100	2.95	2.56	2.35	2.22	2.13	2.06	2.01	1.97	1.93
	.050	4.30	3.44	3.05	2.82	2.66	2.55	2.46	2.40	2.34
	.025	5.79	4.38	3.78	3.44	3.22	3.05	2.93	2.84	2.76
	.010	7.95	5.72	4.82	4.31	3.99	3.76	3.59	3.45	3.35
	.005	9.73	6.81	5.65	5.02	4.61	4.32	4.11	3.94	3.81
23	.100	2.94	2.55	2.34	2.21	2.11	2.05	1.99	1.95	1.92
	.050	4.28	3.42	3.03	2.80	2.64	2.53	2.44	2.37	2.32
	.025	5.75	4.35	3.75	3.41	3.18	3.02	2.90	2.81	2.73
	.010	7.88	5.66	4.76	4.26	3.94	3.71	3.54	3.41	3.30
	.005	9.63	6.73	5.58	4.95	4.54	4.26	4.05	3.88	3.75
24	.100	2.93	2.54	2.33	2.20	2.10	2.04	1.98	1.94	1.91
	.050	4.26	3.40	3.01	2.78	2.62	2.51	2.42	2.36	2.30
	.025	5.72	4.32	3.72	3.38	3.15	2.99	2.87	2.78	2.70
	.010	7.82	5.61	4.72	4.22	3.90	3.67	3.50	3.36	3.26
	.005	9.55	6.66	5.52	4.89	4.49	4.20	3.99	3.83	3.69
25	.100	2.92	2.53	2.32	2.18	2.09	2.02	1.97	1.93	1.89
	.050	4.24	3.39	2.99	2.76	2.60	2.49	2.40	2.34	2.28
	.025	5.69	4.29	3.69	3.35	3.13	2.97	2.85	2.75	2.68
	.010	7.77	5.57	4.68	4.18	3.85	3.63	3.46	3.32	3.22
	.005	9.48	6.60	5.46	4.84	4.43	4.15	3.94	3.78	3.64
26	.100	2.91	2.52	2.31	2.17	2.08	2.01	1.96	1.92	1.88
	.050	4.23	3.37	2.98	2.74	2.59	2.47	2.39	2.32	2.27
	.025	5.66	4.27	3.67	3.33	3.10	2.94	2.82	2.73	2.65
	.010	7.72	5.53	4.64	4.14	3.82	3.59	3.42	3.29	3.18
	.005	9.41	6.54	5.41	4.79	4.38	4.10	3.89	3.73	3.60
27	.100	2.90	2.51	2.30	2.17	2.07	2.00	1.95	1.91	1.87
	.050	4.21	3.35	2.96	2.73	2.57	2.46	2.37	2.31	2.25
	.025	5.63	4.24	3.65	3.31	3.08	2.92	2.80	2.71	2.63
	.010	7.68	5.49	4.60	4.11	3.78	3.56	3.39	3.26	3.15
	.005	9.34	6.49	5.36	4.74	4.34	4.06	3.85	3.69	3.56
28	.100	2.89	2.50	2.29	2.16	2.06	2.00	1.94	1.90	1.87
	.050	4.20	3.34	2.95	2.71	2.56	2.45	2.36	2.29	2.24
	.025	5.61	4.22	3.63	3.29	3.06	2.90	2.78	2.69	2.61
	.010	7.64	5.45	4.57	4.07	3.75	3.53	3.36	3.23	3.12
	.005	9.28	6.44	5.32	4.70	4.30	4.02	3.81	3.65	3.52

Table 7 (Continued)

Denominator df	F_{α}										
	α	10	12	15	20	24	30	40	60	120	∞
22	.100	1.90	1.86	1.81	1.76	1.73	1.70	1.67	1.64	1.60	1.57
	.050	2.30	2.23	2.15	2.07	2.03	1.98	1.94	1.89	1.84	1.78
	.025	2.70	2.60	2.50	2.39	2.35	2.27	2.21	2.14	2.08	2.00
	.010	3.26	3.12	2.98	2.83	2.75	2.67	2.58	2.50	2.40	2.31
	.005	3.70	3.54	3.36	3.18	3.08	2.98	2.88	2.77	2.66	2.55
23	.100	1.89	1.84	1.80	1.74	1.72	1.69	1.66	1.62	1.59	1.55
	.050	2.27	2.20	2.13	2.05	2.01	1.96	1.91	1.86	1.81	1.76
	.025	2.67	2.57	2.47	2.36	2.30	2.24	2.18	2.11	2.04	1.97
	.010	3.21	3.07	2.93	2.78	2.70	2.62	2.54	2.45	2.35	2.26
	.005	3.64	3.47	3.30	3.12	3.02	2.92	2.82	2.71	2.60	2.48
24	.100	1.88	1.83	1.78	1.73	1.70	1.67	1.64	1.61	1.57	1.53
	.050	2.25	2.18	2.11	2.03	1.98	1.94	1.89	1.84	1.79	1.73
	.025	2.64	2.54	2.44	2.33	2.27	2.21	2.15	2.08	2.01	1.94
	.010	3.17	3.03	2.89	2.74	2.66	2.58	2.49	2.40	2.31	2.21
	.005	3.59	3.42	3.25	3.06	2.97	2.87	2.77	2.66	2.55	2.43
25	.100	1.87	1.82	1.77	1.72	1.69	1.66	1.63	1.59	1.56	1.52
	.050	2.24	2.16	2.09	2.01	1.96	1.92	1.87	1.82	1.77	1.71
	.025	2.61	2.51	2.41	2.30	2.24	2.18	2.12	2.05	1.98	1.91
	.010	3.13	2.99	2.85	2.70	2.62	2.54	2.45	2.36	2.27	2.17
	.005	3.54	3.37	3.20	3.01	2.92	2.82	2.72	2.61	2.50	2.38
26	.100	1.86	1.81	1.76	1.71	1.68	1.65	1.61	1.58	1.54	1.50
	.050	2.22	2.15	2.07	1.99	1.95	1.90	1.85	1.80	1.75	1.69
	.025	2.59	2.49	2.39	2.28	2.22	2.16	2.09	2.03	1.95	1.88
	.010	3.09	2.96	2.81	2.66	2.58	2.50	2.42	2.33	2.23	2.13
	.005	3.49	3.33	3.15	2.97	2.87	2.77	2.67	2.56	2.45	2.33
27	.100	1.85	1.80	1.75	1.70	1.67	1.64	1.60	1.57	1.53	1.49
	.050	2.20	2.13	2.06	1.97	1.93	1.88	1.84	1.79	1.73	1.67
	.025	2.57	2.47	2.36	2.25	2.19	2.13	2.07	2.00	1.93	1.85
	.010	3.06	2.93	2.78	2.63	2.55	2.47	2.38	2.29	2.20	2.10
	.005	3.45	3.28	3.11	2.93	2.83	2.73	2.63	2.52	2.41	2.29
28	.100	1.84	1.79	1.74	1.69	1.66	1.63	1.59	1.56	1.52	1.48
	.050	2.19	2.12	2.04	1.96	1.91	1.87	1.82	1.77	1.71	1.65
	.025	2.55	2.45	2.34	2.23	2.17	2.11	2.05	1.98	1.91	1.83
	.010	3.03	2.90	2.75	2.60	2.52	2.44	2.35	2.26	2.17	2.06
	.005	3.41	3.25	3.07	2.89	2.79	2.69	2.59	2.48	2.37	2.25

Table 7 (Continued)

Denominator df	F_{α}									
	α	1	2	3	4	5	6	7	8	9
15	.100	3.07	2.70	2.49	2.36	2.27	2.21	2.16	2.12	2.09
	.050	4.54	3.68	3.29	3.06	2.90	2.79	2.71	2.64	2.59
	.025	6.70	4.77	4.15	3.80	3.58	3.41	3.29	3.20	3.12
	.010	8.68	6.36	5.42	4.89	4.56	4.32	4.14	4.00	3.89
	.005	10.80	7.70	6.48	5.80	5.37	5.07	4.85	4.67	4.54
16	.100	3.05	2.67	2.46	2.33	2.24	2.18	2.13	2.09	2.06
	.050	4.49	3.63	3.24	3.01	2.85	2.74	2.66	2.59	2.54
	.025	6.12	4.69	4.08	3.73	3.50	3.34	3.22	3.12	3.05
	.010	8.53	6.23	5.29	4.77	4.44	4.20	4.03	3.89	3.78
	.005	10.58	7.51	6.30	5.64	5.21	4.91	4.69	4.52	4.38
17	.100	3.03	2.64	2.44	2.31	2.22	2.15	2.10	2.06	2.03
	.050	4.45	3.59	3.20	2.96	2.81	2.70	2.61	2.55	2.49
	.025	6.04	4.62	4.01	3.66	3.44	3.28	3.16	3.06	2.98
	.010	8.40	6.11	5.18	4.67	4.34	4.10	3.93	3.79	3.68
	.005	10.38	7.35	6.16	5.50	5.07	4.78	4.56	4.39	4.25
18	.100	3.01	2.62	2.42	2.29	2.20	2.13	2.08	2.04	2.00
	.050	4.41	3.55	3.16	2.93	2.77	2.66	2.58	2.51	2.46
	.025	5.98	4.56	3.95	3.61	3.38	3.22	3.10	3.01	2.93
	.010	8.29	6.01	5.09	4.58	4.25	4.01	3.84	3.71	3.60
	.005	10.22	7.21	6.03	5.37	4.96	4.66	4.44	4.28	4.14
19	.100	2.99	2.61	2.40	2.27	2.18	2.11	2.06	2.02	1.98
	.050	4.38	3.52	3.13	2.90	2.74	2.63	2.54	2.48	2.42
	.025	5.92	4.51	3.90	3.56	3.33	3.17	3.05	2.96	2.88
	.010	8.18	5.93	5.01	4.50	4.17	3.94	3.77	3.63	3.52
	.005	10.07	7.09	5.92	5.27	4.85	4.56	4.34	4.18	4.04
20	.100	2.97	2.59	2.38	2.25	2.16	2.09	2.04	2.00	1.96
	.050	4.35	3.49	3.10	2.87	2.71	2.60	2.51	2.45	2.39
	.025	5.87	4.46	3.86	3.51	3.29	3.13	3.01	2.91	2.84
	.010	8.10	5.85	4.94	4.43	4.10	3.87	3.70	3.56	3.46
	.005	9.94	6.99	5.82	5.17	4.76	4.47	4.26	4.09	3.95
21	.100	2.96	2.57	2.36	2.23	2.14	2.08	2.02	1.98	1.95
	.050	4.32	3.47	3.07	2.84	2.68	2.57	2.49	2.42	2.37
	.025	5.83	4.42	3.82	3.48	3.25	3.09	2.97	2.87	2.80
	.010	8.02	5.78	4.87	4.37	4.04	3.81	3.64	3.51	3.40
	.005	9.83	6.89	5.73	5.09	4.68	4.39	4.18	4.01	3.88

Table 7 (Continued)

Denominator df	F_{α}										
	10	12	15	20	24	30	40	60	120	∞	α
15	2.06	2.02	1.97	1.92	1.90	1.87	1.85	1.82	1.79	1.76	.100
	2.54	2.48	2.40	2.33	2.29	2.25	2.20	2.16	2.11	2.07	.050
	3.06	2.96	2.86	2.76	2.70	2.64	2.59	2.52	2.46	2.40	.025
	3.80	3.67	3.52	3.37	3.29	3.21	3.13	3.05	2.96	2.87	.010
	4.42	4.25	4.07	3.88	3.79	3.69	3.58	3.48	3.37	3.26	.005
16	2.03	1.99	1.94	1.89	1.87	1.84	1.81	1.78	1.75	1.72	.100
	2.49	2.42	2.35	2.28	2.24	2.19	2.15	2.11	2.06	2.01	.050
	2.99	2.89	2.79	2.68	2.63	2.57	2.51	2.45	2.38	2.32	.025
	3.69	3.55	3.41	3.26	3.18	3.10	3.02	2.93	2.84	2.75	.010
	4.27	4.10	3.92	3.73	3.64	3.54	3.44	3.33	3.22	3.11	.005
17	2.00	1.96	1.91	1.86	1.84	1.81	1.78	1.75	1.72	1.69	.100
	2.45	2.38	2.31	2.23	2.19	2.15	2.10	2.06	2.01	1.96	.050
	2.92	2.82	2.72	2.62	2.56	2.50	2.44	2.38	2.32	2.25	.025
	3.59	3.46	3.31	3.16	3.08	3.00	2.92	2.84	2.75	2.65	.010
	4.14	3.97	3.79	3.61	3.51	3.41	3.31	3.21	3.10	2.98	.005
18	1.98	1.93	1.89	1.84	1.81	1.78	1.75	1.72	1.69	1.66	.100
	2.41	2.34	2.27	2.19	2.15	2.11	2.06	2.02	1.97	1.92	.050
	2.87	2.77	2.67	2.56	2.50	2.44	2.38	2.32	2.26	2.19	.025
	3.51	3.37	3.23	3.08	3.00	2.92	2.84	2.75	2.66	2.57	.010
	4.03	3.86	3.68	3.50	3.40	3.30	3.20	3.10	2.99	2.87	.005
19	1.96	1.91	1.86	1.81	1.79	1.76	1.73	1.70	1.67	1.63	.100
	2.38	2.31	2.23	2.16	2.11	2.07	2.03	1.98	1.93	1.88	.050
	2.82	2.72	2.62	2.51	2.45	2.39	2.33	2.27	2.20	2.13	.025
	3.43	3.30	3.15	3.00	2.92	2.84	2.76	2.67	2.58	2.49	.010
	3.93	3.76	3.59	3.40	3.31	3.21	3.11	3.00	2.89	2.78	.005
20	1.94	1.89	1.84	1.79	1.77	1.74	1.71	1.68	1.64	1.61	.100
	2.35	2.28	2.20	2.12	2.08	2.04	1.99	1.95	1.90	1.84	.050
	2.77	2.68	2.57	2.46	2.41	2.35	2.29	2.22	2.16	2.09	.025
	3.37	3.23	3.09	2.94	2.86	2.78	2.69	2.61	2.52	2.42	.010
	3.85	3.68	3.50	3.32	3.22	3.12	3.02	2.92	2.81	2.69	.005
21	1.92	1.87	1.83	1.78	1.75	1.72	1.69	1.66	1.62	1.59	.100
	2.32	2.25	2.18	2.10	2.05	2.01	1.96	1.92	1.87	1.81	.050
	2.73	2.64	2.53	2.42	2.37	2.31	2.25	2.18	2.11	2.04	.025
	3.31	3.17	3.03	2.88	2.80	2.72	2.64	2.55	2.46	2.36	.010
	3.77	3.60	3.43	3.24	3.15	3.05	2.95	2.84	2.73	2.61	.005

Table 7 (Continued)

Denominator df	α	F_{α}								
		1	2	3	4	5	6	7	8	9
29	.100	2.89	2.50	2.28	2.15	2.06	1.99	1.93	1.89	1.86
	.050	4.18	3.33	2.93	2.70	2.55	2.43	2.35	2.28	2.22
	.025	5.59	4.20	3.61	3.27	3.04	2.88	2.76	2.67	2.59
	.010	7.60	5.42	4.54	4.04	3.73	3.50	3.33	3.20	3.09
	.005	9.23	6.40	5.28	4.66	4.26	3.98	3.77	3.61	3.48
30	.100	2.88	2.49	2.28	2.14	2.05	1.98	1.93	1.88	1.85
	.050	4.17	3.32	2.92	2.69	2.53	2.42	2.33	2.27	2.21
	.025	5.57	4.18	3.59	3.25	3.03	2.87	2.75	2.65	2.57
	.010	7.56	5.39	4.51	4.02	3.70	3.47	3.30	3.17	3.07
	.005	9.18	6.35	5.24	4.62	4.23	3.95	3.74	3.58	3.45
40	.100	2.84	2.44	2.23	2.09	2.00	1.93	1.87	1.83	1.79
	.050	4.08	3.23	2.84	2.61	2.45	2.34	2.25	2.18	2.12
	.025	5.42	4.05	3.46	3.13	2.90	2.74	2.62	2.53	2.45
	.010	7.31	5.18	4.31	3.83	3.51	3.29	3.12	2.99	2.89
	.005	8.83	6.07	4.98	4.37	3.99	3.71	3.51	3.35	3.22
60	.100	2.79	2.39	2.18	2.04	1.95	1.87	1.82	1.77	1.74
	.050	4.00	3.15	2.76	2.53	2.37	2.25	2.17	2.10	2.04
	.025	5.29	3.93	3.34	3.01	2.79	2.63	2.51	2.41	2.33
	.010	7.08	4.98	4.13	3.65	3.34	3.12	2.95	2.82	2.72
	.005	8.49	5.79	4.73	4.14	3.76	3.49	3.29	3.13	3.01
120	.100	2.75	2.35	2.13	1.99	1.90	1.82	1.77	1.72	1.68
	.050	3.92	3.07	2.68	2.45	2.29	2.17	2.09	2.02	1.96
	.025	5.15	3.80	3.23	2.89	2.67	2.52	2.39	2.30	2.22
	.010	6.85	4.79	3.95	3.48	3.17	2.96	2.79	2.66	2.56
	.005	8.18	5.54	4.50	3.92	3.55	3.28	3.09	2.93	2.81
∞	.100	2.71	2.30	2.08	1.94	1.85	1.77	1.72	1.67	1.63
	.050	3.84	3.00	2.60	2.37	2.21	2.10	2.01	1.94	1.88
	.025	5.02	3.69	3.12	2.79	2.57	2.41	2.29	2.19	2.11
	.010	6.63	4.61	3.78	3.32	3.02	2.80	2.64	2.51	2.41
	.005	7.88	5.30	4.28	3.72	3.35	3.09	2.90	2.74	2.62

From "Tables of percentage points of the inverted beta (F') distribution," *Biometrika*, Vol. 33 (1943) by M. Kerrington and C. M. Thompson and from Table 18 of *Biometrika Tables for Statisticians*, Vol. 1, Cambridge University Press, 1954, edited by E. S. Pearson and H. O. Hartley.



**THE UNIVERSITY OF ZAMBIA
SCHOOL OF AGRICULTURAL SCIENCES
DEPARTMENT OF FOOD SCIENCE & NUTRITION**

BACHELOR OF FOOD SCIENCE AND TECHNOLOGY

FUNDAMENTALS OF ELECTRICAL ENGINEERING FOR FOOD SCIENCE

AGF 2251

2021-2022 MID-YEAR EXAMINATIONS

DURATION: THREE (3) HOURS

VENUE: OMINIA 3

DATE: 15/06/2022

TIME: 0:900 HRS

INSTRUCTIONS TO THE CANDIDATES:

1. PLEASE READ THE INSTRUCTIONS AND EACH QUESTION CAREFULLY.
2. THIS PAPER HAS **FOUR** QUESTIONS AND EACH CARRIES **25 MARKS**
3. ANSWER ALL QUESTIONS.

QUESTION 1 [25 points]

- a) What does it mean a circuit is open or closed? (5 points)
- b) List two types of voltmeters and give one reason why these devices should have infinitely high resistance? (3 points)
- c) Define a series-parallel circuit? (2 points)
- d) What determines the amount of current in each branch of a parallel circuit? (5 points)
- e) Provide a detailed description of an inductor in respect to its being a passive circuit element (5 points)
- f) Define the following electrical engineering terms:
 - (i) Charge (2 points)
 - (ii) Direct current (2 points)
 - (iii) Power (1 points)

QUESTION 2 [25 points]

Five elemental resistors of a boiler used to generate steam for a steam jacketed milk pasteurizer are connected in a circuit as shown in Figure 1.

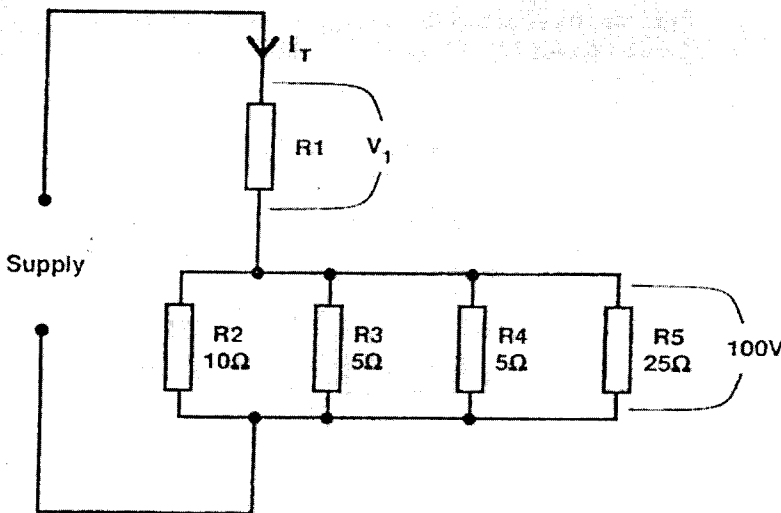

Figure 1. Four elemental boiler system

- a) Calculate the current through R1. (8 points).
- b) What happens to the current in a series circuit if the total resistance is doubled? (5 points)
- c) How will an open resistor affect a series circuit (2.5 points)

- d) Describe the features of a series circuit. (4 points)
- e) Using the I-V graph, show how a non-ohmic conductor behave. Why do these conductors behave this way? (5 points)

QUESTION 3 [25 points]

- a) A single-phase transformer has 120 Volts on the primary with 24 Volts on the secondary. The transformer is feeding a 500 Watt load with an efficiency of 95 percent. Calculate:
 - (i) Secondary Amps (5 points)
 - (ii) Primary Volt-Amps (5 points)
 - (iii) Primary Amps (5 points)
 - (iv) Why are transformers considered linear devices? (5 points)
 - (v) Describe an impedance transformer and its area of application (5 points)

QUESTION 4 [25 points]

- a) Electric motors and generators are very important machines that have found widespread application in the food industry.
 - (i) Give one key difference between the synchronous and asynchronous motors (6 points)
 - (ii) Describe the working principle of an electric generator (4 points)
 - (iii) List five factors that may cause burning out of electric motor in the food industry operations (2.5 points)
 - (iv) Give 5 examples of mechanical drive operations in the food industry that are aided by an electrical motor (2.5 points)
- b) ETHANISA Electricals Limited of Themisa Island would like to set a nuclear power generation plant in Zambia and has approached you for technical advice. Please write a summarized report to guide the client. No gambling please! (10 points)

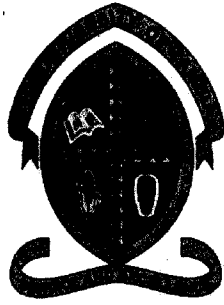

**THE UNIVERSITY OF ZAMBIA
SCHOOL OF AGRICULTURAL SCIENCES
DEPARTMENT OF FOOD SCIENCE & NUTRITION
2020/21 ACADEMIC YEAR FINAL EXAMINATIONS**

**AGF 2262
FUNDAMENTALS OF ENGINEERING DRAWING**

Date: 16TH November, 2022

Time: 09:00 - 12:00 HRS

Venue: TBA

Duration: Three (3) HOURS

INSTRUCTIONS TO THE CANDIDATES:

- 1. THIS PAPER CARRIES 60 MARKS AND HAS A TOTAL OF THREE (3) QUESTIONS**
- 2. ANSWER QUESTIONS 1 & 2 ON THE SAME A3 PAPER**
- 3. QUESTION 3 SHOULD BE ANSWERED ON A SEPARATE A3**
- 4. ATTEMPT ALL QUESTIONS**
- 5. USE ILLUSTRATIONS WHERE NECESSARY**



THE UNIVERSITY OF ZAMBIA
School of Agricultural Sciences
Department of Food Science and Nutrition

INTRODUCTION TO INFORMATION TECHNOLOGY AND COMMUNICATION
AGF 2401

2021-2022 FINAL EXAM

Date: 21st JUNE 2022
Venue: OMNIA 1
Time: 9:00 TO 12:00 HOURS
Duration: 3 Hours

Instructions

- 1. This examination has one section*
- 2. Section A comprises six [6] questions. Answer any five [5] questions. Each question carries 20 marks.*

Section A

Answer any five questions. Each question carries 20 marks.

Question 1

- a) What is Computer? [2] what are the five things you should consider when buying a laptop? [3]
- b) Write short notes on Central Processing Unit, Second generation computers, Fifth generation computers and Mainframe computers? [12]
- c) What is the difference between RAM and ROM? [3]

Question 2

- a) Explain any five different types of Input devices and five different types of output devices? [20]

Question 3

- a) What is storage? [2] what is the purpose of secondary storage medium? [3]
- b) What is the difference between secondary storage and main memory with examples? [3]
- c) Explain the Solid-state drive with examples? [5]
- d) Why backup is important? How you can create a backup? [5]
- e) What is the difference between CD-R and CD-RW? [2]

Question 4

- a) What is a Network? [2] Write any 2 advantages and 2 disadvantages of a Network? [4]
- b) Explain the different devices used in the network? [6]
- c) Describe the different methods of authentication to ensure your login is safe via network? [4]
- d) List the different types of communications? [4]

Question 5

- a) What is a Operating system? [2] Describe any 6 functions of the OS? [6]
- b) Explain any three different types of the operating system? [6]
- c) What is a programming language? [2] Explain the different levels of the programming language? [6]

Question 6

- a) Explain about hacking, computer virus, phishing, pharming, spyware? [10]
How you protect your computer from this above threats? [4]
- b) Explain how ICT helps in Medical field, School Management systems, Monitoring and Tracking systems? [6]



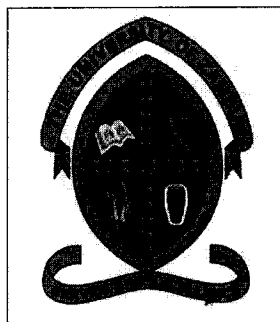

**THE UNIVERSITY OF ZAMBIA
SCHOOL OF AGRICULTURAL SCIENCES
DEPARTMENT OF FOOD SCIENCE & NUTRITION**

2020/21 ACADEMIC YEAR FINAL EXAMINATIONS

**AGF 3042
INSTRUMENTAL METHODS IN FOOD ANALYSIS – SUPPLEMENTARY EXAM**

Date: 14th FEBRUARY, 2022

Time: 09:00 - 10:30 HRS

Venue: OTHER ROOMS

Duration: 1 HOUR 30 MINUTES

INSTRUCTIONS TO THE CANDIDATES:

- 1. THIS PAPER CARRIES 75 MARKS AND HAS A TOTAL OF THREE(3) QUESTIONS**
- 2. EACH QUESTION CARRIES 25 MARKS**
- 3. ANSWER ALL QUESTIONS**
- 4. USE ILLUSTRATIONS WHERE NECESSARY**

QUESTION 1

Figure 1.14 illustrates the components of an HPLC.

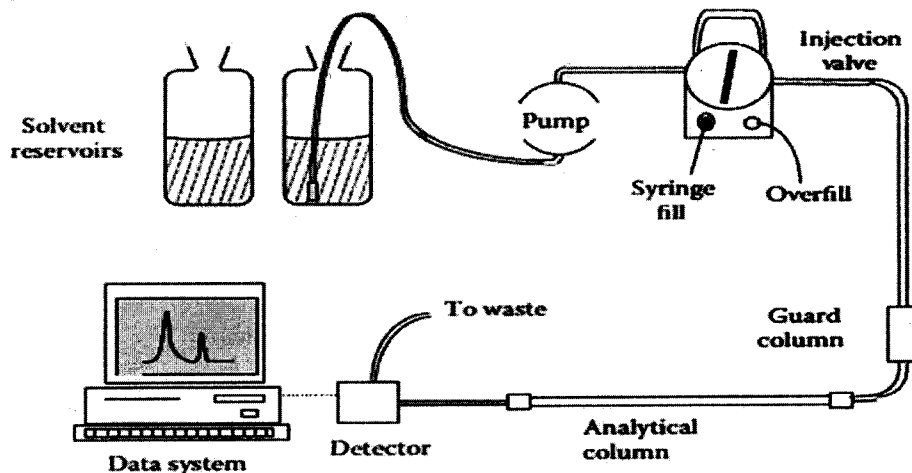

Figure 1.14 HPLC system.

- For each component, state the function(s). (7 Marks)
- The analytical column is considered as the heart of the HPLC. Briefly discuss the any four (4) various types of separations that occur in the column. (12 Marks)
- Give the comparisons between the GC and HPLC? (6 Marks)

QUESTION 2

- What is thermal analysis? In addition, state the properties (giving examples) that are involved in thermal analysis. (6 Marks)
- List and define the three (3) thermal analytical techniques which are applied in thermal analysis. (4 Marks)
- Discuss any two (2) analytical techniques mentioned in part 2(b) and state their applications. Use illustrations and/or diagrams. (15 Marks)

QUESTION 3

A UV/Vis spectrophotometer has been used frequently in the determination of neutral sugars. As a student in Instrumental Methods in Food Analysis, a sample was brought to you for Galacturonic acid (GAIA) determination. After running a set of GAIA standards, the following results were obtained:

Standard (mg GAIA/ml)	Absorbance
0	0.000
1	0.094
3	0.186
6	0.333
9	0.373
12	0.505
15	0.626
18	0.809
20	0.874

You analyzed the sample in triplicates and obtained absorbance readings of 0.765, 0.770 and 0.768, respectively.

- a) What is the concentration of Galacturonic acid in the sample? **(10 Marks)**
- b)
 - i. What does it mean to say that there is a “deviation” from Beer’s law? **(4 Marks)**
 - ii. What is the absorbance given that the absorptivity is $2.30 \times 10^4 \text{ L mol}^{-1} \text{ cm}^{-1}$, the path length is 1.00 cm, and the concentration is 0.0000453 M? **(3 Marks)**
- c)
 - i. What does it mean to say that the cuvettes used must be “matched”? **(2 Marks)**
 - ii. Explain why the cuvettes need to be “matched.” **(3 Marks)**
 - iii. A certain pair of cuvettes is not a matched pair. Tell what exactly may be different about them (Name at least two things over which the analyst does not have any control). **(3 Marks)**

END OF EXAMINATION

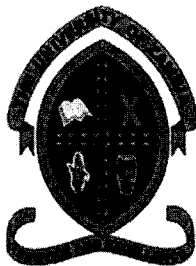

**THE UNIVERSITY OF ZAMBIA
SCHOOL OF AGRICULTURAL SCIENCES
DEPARTMENT OF FOOD SCIENCE & NUTRITION**

2021/22 ACADEMIC YEAR FINAL EXAMINATIONS

**AGF 3042
INSTRUMENTAL METHODS IN FOOD ANALYSIS - PRACTICAL EXAM**

**Date: 2ND NOVEMBER, 2022
Time: 14:00 – 17:00 HOURS
Venue: FOOD CHEMISTRY LAB - FSN**

Duration: 3 HOURS

INSTRUCTIONS TO THE CANDIDATES:

- 1. THIS PAPER HAS A TOTAL OF THREE (3) QUESTIONS.**
- 2. EACH QUESTION CARRIES 25 MARKS.**
- 3. ANSWER ALL QUESTIONS**

QUESTION 1

In AGF 3042 (Instrumental methods in food analysis), you were familiarized with various experiments which involved the use of different instruments. In this practical question, you are provided with a series of stations containing specimens accompanied with questions. Answer all questions. You are advised to spend five (5) minutes on each station. **(25 Marks)**

QUESTION 2

- a) A food scientist determined the concentration of calcium in a sample using UV-Spectroscopy and a cuvette with inside diameter of 1 cm. The scientist diluted 10 ml of original sample with 40 ml distilled water and obtained the absorbance of 0.405 and the corresponding concentration of 2.5 ppm. Calculate the absorptivity and the concentration of the original sample. **(15 Marks)**
- a) Explain in detail the handling of cuvettes in spectroscopy. **(5 Marks)**
- b) Is the Calorimeter different from the UV Spectrophotometer and UV-Vis Spectrometer? YES/NO If YES to a), how are the three types of instrumentations different from each other? **(2 Marks)**
- c) List the different types of refractometers and their application(s) in the food industry. **(3 Marks)**

QUESTION 3

- a) What are steps involved in gel preparation. **(5 Marks)**
- b) Assume that you are a Laboratory Personnel specialised in Proteomics. A client from a different laboratory brings to you three (3) unknown solution samples labelled Sample A, B, and D, respectively. The client suspects that the samples were accidentally swapped in their laboratory and could not tell exactly which sample is which in terms of their nature. After analyzing samples using SDS-PAGE, the following data was collected:

	Tracking Dye	Sample A	Sample B	Sample D
Migration distance (cm)	9.5	7	4.5	2

If the molecular weights of Samples A and D are 25KDa and 125KDa, respectively, what would be the size of Sample B? **(20 Marks)**

END OF EXAMINATION

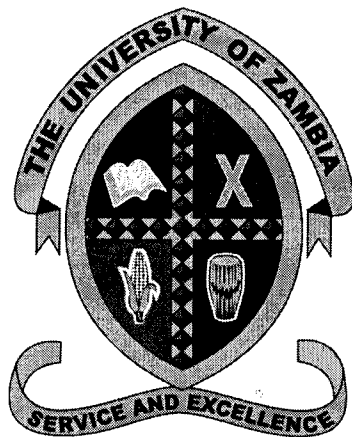

**THE UNIVERSITY OF ZAMBIA
SCHOOL OF AGRICULTURAL SCIENCES
DEPARTMENT OF FOOD SCIENCE & NUTRITION**

**2020/21 ACADEMIC YEAR END OF YEAR FINAL
SUPPLEMENTARY EXAMINATIONS**

**AGF 3100
General and Food Microbiology**

Date: 15th February, 2022

Time: 14:00 to 15:30hrs

Venue: Omnia 1

Duration: ONE HOUR AND THIRTY (30) MINUTES

INSTRUCTIONS TO THE CANDIDATES:

- 1. THIS PAPER CARRIES 100 MARKS.**
- 2. ANSWER ALL THE QUESTIONS.**
- 3. ALLOCATED MARKS FOR EACH QUESTION ARE INDICATED IN THE BRACKETS.**

Question One (1)

- A. Write short notes on the structure and composition, and function of each of the following parts of the prokaryotic cell
- i. Glycocalyx (5 Points)
 - ii. Cytoplasmic membrane (5 Points)
 - iii. Cytoplasm (5 Points)
 - iv. Pili and fimbriae (5 Points)
- B. Describe flagella arrangements and chemotaxis (10 points)
- C. Describe the mechanism of action of microbial control agents (10 Points)

Question Two (2)

- A. Explain in detail why fresh fish easily spoils (8 Marks)
- B. As a food microbiologist, recommend to a fresh fish seller at a Local Market two (2) ways of preventing and or minimising fresh fish spoilage (5 Marks)
- C. Fresh fish is associated with *Salmonella*
- i. List any two types of *Salmonella* antigens (3 Marks)
 - ii. List four (4) common virulent factors of gram negative bacteria such as *Salmonella* (6 Marks)
 - iii. Explain how lack of refrigeration for several hours and inadequate reheating before serving contribute to development of Salmonellosis (6 Marks)
 - iv. Describe in detail at least four (4) hurdles that must be overcome by *Salmonella* in order to demonstrate that the organism is a food borne pathogen that cause intestinal disease (10 Points)
 - v. Differentiate between food infection and food intoxication (2 Points)

Question Three (3)

- A. List any six (6) parts of the compound light microscope and describe the functions of the listed parts (12 Marks)
- B. Define field of vision (2 Mark)
- C. Explain how you obtain the total magnification when using a compound light microscope (2 Marks)
- D. Define aseptic techniques and explain why aseptic techniques are important? (3Marks)
- E. List three common shapes of bacteria (1 Mark)

END OF EXAMINATION

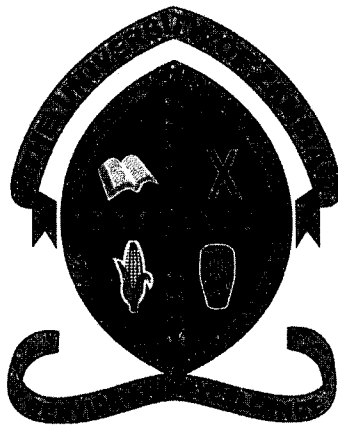

**THE UNIVERSITY OF ZAMBIA
SCHOOL OF AGRICULTURAL SCIENCES
DEPARTMENT OF FOOD SCIENCE & NUTRITION**

**2021/2022 ACADEMIC YEAR END OF YEAR FINAL
EXAMINATIONS**

**AGF 3100
General and Food Microbiology (Practical)**

Date: 31st October, 2022

Time: 14:00 to 17:00 hrs

Venue: Omnia 1 & 2

Duration: THREE (3) HOURS

INSTRUCTIONS TO THE CANDIDATES:

- 1. THIS PAPER CARRIES 100 MARKS.**
- 2. ANSWER ALL THE QUESTIONS.**
- 3. ALLOCATED MARKS FOR EACH QUESTION ARE INDICATED IN THE BRACKETS.**

Question One (1)

- a) Define the following terms
 - a. Microscopy (2 Marks)
 - b. Field of view on a microscope (2 Marks)
- b) Explain why a microscope is important in microbiology (2 Marks)
- c) Distinguish between the resolving power and magnifying power of a microscope. Explain how you determine the total magnification of an image viewed through the microscope (6 Marks)
- d) Name two ways of how to obtain optimal (maximum) resolution when using a light microscope (3 Marks)
- e) Give one limitation of using a light microscope (2 Marks)
- f) Draw the two bacterial shapes you observed during the experiment and give the genus names of the bacteria drawn (3 Marks)

Question Two (2)

- a) Explain in detail how you would prepare a fixed stained smear (5 Marks)
- b) Briefly explain the principle behind direct staining and the importance of direct staining. What types of dyes are used in direct staining? (5 Marks)
- c) In a gram stain, can iodine be added before the primary stain? Explain your reasoning (4 Marks)
- d) Explain what would happen if you gram stain human cells (2 Marks)
- e) Select a sterilizing method you would use for the following and explain your choice of sterilizing method
 - i. Culture media (2 Marks)
 - ii. Heat sensitive liquids (2 Marks)

Question Three (3)

- a) What are aseptic techniques and why are they important? List two (2) that are performed during microbiological analyses (5 Marks)
- b) Define culture media (2 Marks)
- b) Contrast Selective media, Differential media and Enrichment media (6 Marks)
- c) What is the difference between chemically defined and complex media (3 Marks)
- d) Describe the characteristics of Agar an extract from marine algae (4 Marks)

Question Four (4)

- a) Describe the procedure for gelatin hydrolysis and how to interpret the results (6 Marks)
- b) Contrast aerobic respiration, anaerobic respiration and fermentation (3 Marks)

- c) Name the general end products that may be formed as a result of the bacterial fermentation of sugars **(2 Marks)**
- d) From the information provided in the table below, calculate the number of colony forming units per ml. show your calculation **(4 Marks)**

Dilution	Number of colonies
10^{-2}	240
10^{-2}	235
10^{-3}	25
10^{-3}	26
10^{-4}	2
10^{-4}	3

- e) What is the purpose of serial dilutions in the enumeration of microorganisms **(2 Marks)**
- f) Could some bacteria grow on the streak plate and not be seen on the pour plate technique? Explain **(3 Marks)**

Question Five (5)

A client is opening a business of supplying indigenous fresh vegetables to a local supermarket. The client brings a sample of fresh amaranth (Bondwe) (500g) to your lab to help determine the microbiological safety. Among the requirements is the preparation of nutrient culture media.

Materials		
250ml Erlenmeyer Flask with cap or plug	Glass Stirring Rod	45°C Water Bath
100ml Graduated Cylinder	Sterile Petri Dishes	Nutrient Broth Powder
Weighing Balance	Hot Plate	Nutrient Agar Powder
Weighing Dish	Autoclave	Distilled water
5ml Pipette	Autoclave gloves	Dispenser

- a) With the above provided materials, explain in detail the procedure of how you would prepare the following culture media
- Test tubes of 5ml Nutrient Broth **(6 Marks)**
 - Nutrient Agar Plates **(12 Marks)**
- b) Explain why it is important when pouring agar media to not allow agar touch the sides or covers of the plates **(2 Marks)**

END OF EXAMINATION

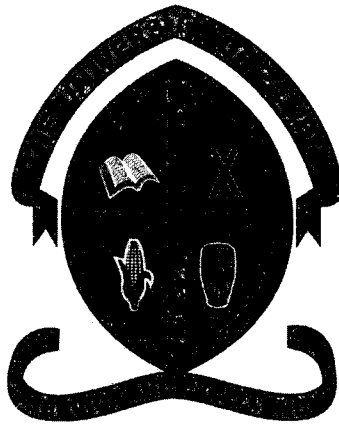

**THE UNIVERSITY OF ZAMBIA
SCHOOL OF AGRICULTURAL SCIENCES
DEPARTMENT OF FOOD SCIENCE & NUTRITION**

**2021/22 ACADEMIC YEAR END OF YEAR FINAL
EXAMINATIONS**

**AGF 3100
General and Food Microbiology (Theory)**

Date: 18th November, 2022

Time: 14 to 17 Hrs

Venue: Omnia

Duration: THREE HOURS

INSTRUCTIONS TO THE CANDIDATES:

- 1. THIS PAPER CARRIES 100 MARKS AND HAS TWO (2) SECTIONS; A AND B**
- 2. ANSWER ALL THE QUESTIONS IN SECTION A AND ANY ONE (1) QUESTION IN SECTION B.**
- 3. ALLOCATED MARKS FOR EACH QUESTION ARE INDICATED IN THE BRACKETS.**

SECTION A

There are **FOUR (4)** questions - Answer **ALL FOUR (4)** questions in this section

Question 1

- a. Most microorganisms are unicellular. What is meant by a unicellular organism? [2 Marks]
- b. Microorganisms are associated with the health and welfare of human beings. Describe **two (2)** ways in which microorganisms are beneficial and **two (2)** ways in which they are detrimental to humans [4 Marks]
- c. Write short notes on the structure and composition, and function of each of the following parts of the prokaryotic cell
- i. Glycocalyx [4 Marks]
 - ii. Cell wall [4 Marks]
- d. Describe any **two (2)** of contributions to the field of microbiology made by the following? And what is the significance of their contribution to modern microbiology?
- i. Robert Hook [3 Marks]
 - ii. Antoine Van Leeuwenhoek [3 Marks]
 - iii. Louis Pasteur [3 Marks]
 - iv. Alexander Fleming [3 Marks]

Question 2

- a. Describe the life cycle of the fungi *Rhizopus stolonifer* (common bread mold) [10 Marks]
- b. Outline steps and mechanisms involved in the infection of a host cell by animal and bacterial viruses [10 Marks]

Question 3

- a. Differentiate between pasteurization and pascalization. Give one (1) advantage and one (1) disadvantage for each of the above methods of food preservation [8 Marks]
- b. Define Redox Potential (Eh) [2 Marks]
- c. Explain in detail how microorganisms affect the redox potential of their environment during growth [4 Marks]

- d. Give an example of a microorganism that would grow in the following conditions and explain why [6 Marks]
- i. Negative Eh (e.g. -200mV)
 - ii. Positive Eh (e.g. +300mV)
 - iii. Slightly reduced conditions
 - iv. Both negative and positive Eh

Question 4

- a. Explain in detail how sodium chloride function as antimicrobial compounds in food preservation and explain how microorganisms respond to the stress of sodium chloride [5 Marks]
- b. Explain how microwaves function in food preservation. Give one (1) advantage and one (1) disadvantage of using microwaves in food preservation [5 Marks]
- c. Explain in detail how non-ionizing and ionising radiation destroy microbial cells. Describe two (2) factors that influence the radiation resistance of microorganisms [9 Marks]

SECTION B

There are **TWO (2)** questions - Answer **ANY ONE (1)** of the two questions in this section

Question 5

- a. State and describe **two** different arrangements for each of the following
- i. Cocci [2 Marks]
 - ii. Bacilli [2 Marks]
- b. Describe any two (2) results of base pair substitutions [4 Marks]
- c. Describe Generalised and Specialised Transduction [3 Marks]
- d. Describe any two (2) characteristics that distinguish specific immunity for non-specific immunity [4 Marks]

Question 6

- a. Explain in detail why fresh fish easily spoils [5 Marks]
- b. Fresh fish is associated with *Salmonella*
- i. List any two types of *Salmonella* antigens [2 Marks]
 - ii. List any two (2) of the common virulent factors associated with gram-negative bacteria such as *Salmonella* [2 Marks]
 - iii. List two (2) foods associated with *Salmonella* [1 Mark]
- c. Mineral deposits such as milk stones (in dairy industry) are nearly impossible to remove with alkaline cleaners. What means of removing mineral deposits would you recommend? [2 Marks]
- d. Identify any two (2) commonly used household detergents, state two active ingredients and explain how the ingredients help in cleaning dirt [4 Marks]
- e. Write short notes on dry cleaning [4 Marks]

END OF EXAMINATION

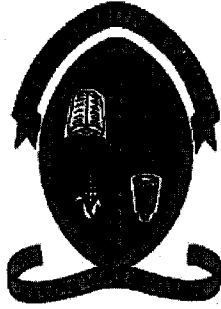

**THE UNIVERSITY OF ZAMBIA
SCHOOL OF AGRICULTURAL SCIENCES
DEPARTMENT OF FOOD SCIENCE AND NUTRITION**

2022 ACADEMIC YEAR – FINAL EXAMINATIONS

**COURSE: AGF 4052
Sensory Evaluation of Foods**

Date: Friday, 18th November 2022

Time: 14.00 – 17.00 Hours

Duration: THREE (3) HOURS

Venue: Omnia 2

INSTRUCTIONS TO CANDIDATES:

1. There are two (2) sections in this examination paper, Section A and Section B.
2. **Section A and Section B carry equal marks (50 marks).** The marks allocated are given at the end of each question.
3. Answers to the two sections should be given in separate booklets. Clearly label each booklet as Section A and Section B.
4. Find also attached **table T4** – Upper α -probability points of student's t-distribution, **table T5** – Upper α -probability points of χ^2 -distribution and **table T6**-Upper α -probability points of F-distribution

SECTION A: Answer all Questions

QUESTION 1

(a) State two (2) differences between the following pairs;

- (i) Parametric and non-parametric tests [1 mark]
- (ii) Gustation and trigeminal perceptions [1 mark]
- (iii) Difference-From-Control and the Simple Difference Tests [1 mark]
- (iv) Interval and nominal data [1 mark]
- (v) Kinesthetic and somesthetic perceptions [1 mark]

(b) In sensory evaluation,

- (i) What are overall and attribute difference tests? [3 marks]
- (ii) Briefly, describe how you as a sensory analyst would practically carry out any one of the overall difference tests and any one of the attribute tests [2 marks]
- (iii) The definition of thresholds in sensory evaluation has various dimensions. Mention and adequately define two (2) terms used to define threshold. [3 marks]
- (iv) In the Duo-trio-test, two forms of the test exist. Mention the two and explain the difference between the two forms of the test? [2 marks]

(c) There are six major sensorial perceptions, namely, vision, touch, olfaction, trigeminal, gustation and hearing. For the vision, touch, olfaction, trigeminal and gustation, state one important sensory concern about each of these perceptions which can affect the abilities of the panelists to evaluate food [5 marks]

QUESTION 2

A drink manufacturer wishes to replace his regular preservative, potassium sorbate, with a newly introduced preservative 'mwenge' on the Zambian market. It has been proven that the new preservative is as effective as the regular preservative in its preservative properties. The new preservative is also cheaper than the regular preservative. The company marketing the new preservative claims that the drinks made using 'mwenge' preservative tastes the same as that made using potassium sorbate. However, it's a known fact that both preservatives cause carryover taste effects when the drinks are tasted. The drink manufacturer hires you as a Sensory Consultant to advise him/her on the following:

- Determine if the two types of drinks produced by the two preservatives can be distinguished by taste

- Determine if the new 'mwenge' preservative can be used in place of potassium sorbate.

To provide the drink manufacturer with the information to his queries, you conducted a sensory test. In this sensory test, you obtained a total of 70 responses, 35 matched and 35 unmatched pairs, collected from 70 panelists. Each panelist evaluated either a matched pair (K-Sorbate/K-Sorbate or mwenge/mwenge) drinks or unmatched pair (K-Sorbate/mwenge or mwenge/K-Sorbate) drinks in a single session. Within the matched pairs, 20 panelists said the samples were the same and 15 panelists said the samples were different. On the other hand, in the unmatched pairs, 24 panelists said the samples were different and 11 panelists said the samples were the same.

- (i) State with reason(s) what kind of sensory test you carried out to obtain this kind of data
[2 marks]
- (ii) Give advice, outlining your basis, to the drink manufacturer regarding his queries above
[10 marks]
- (iii) What decision is the drink manufacturer likely to make?
[3 marks]

QUESTION 3

Eight panelists assessed for a single quality attribute on a new maheu product on a given scale. Each panelist retested the new maheu on six successive days (six replications). The panelists involved in the sensory evaluation were Abel, Bob, Cynthia, Derick, Emery, Fordson, Gibbson and Harriate. Each of the panelists scored: 7, 4, 6, 9, 8 and 6; 6, 3, 5, 7, 8 and 7; 5, 7, 8, 8, 7 and 7; 6, 8, 8, 6, 7 and 6; 7, 6, 8, 5, 6 and 5; 8, 5, 7, 7, 9 and 6; 7, 7, 7, 8, 7 and 5; and, 6, 8, 6, 7, 7 and 5. Assume the scores to come from normally distributed data and having come from populations with the same variance.

- Was the overall performance of the panelists significantly different?
- Which panelists scored differently?
- Was the panel consistent over replications?
- Identify the sets of replications which are different?
- Would you recommend for the continuous use of this panel? Explain your answer

[15 marks]

USEFUL INFORMATION FOR SECTION A

$$\text{LSD} = t \cdot \text{SQRT}(2 \cdot \text{MS}_E / n)$$

where t is the t -value for the level of significance of the ANOVA, SQRT= Square root, MS_E = Error Mean Square for the ANOVA and degrees of freedom being equal to the degrees of freedom of the error term (df_E).

SECTION B: ANSWER ALL QUESTIONS

QUESTION 1

(i) Under Selection for Difference Tests, list and describe four areas of sensory evaluation. Describe the four areas, which the trainees need to know in order to become good food testing panelists.

[15 marks]

(ii) What are acuity test?

[5 marks]

QUESTION 2

To be part of the Panel for Descriptive Tests, name and describe two areas that a trainees has to know in order to qualify to be part of the Descriptive Test Panel

[10 marks]

QUESTION 3

From a Project perspective, name and describe two categories where resources for consumer tests are usually found and why?

[11 marks]

QUESTION 4

Put yourself in the feet of the trainer to the trainees. How would you make the trainees understand the significance of using QUALITATIVE AND QUANTITATIVE DATA IN PRODUCT DEVELOPMENT using figures and tables? Explain with clarity how you would deliver this message to the trainees.

[9 marks]

END



**THE UNIVERSITY OF ZAMBIA
SCHOOL OF AGRICULTURAL SCIENCES
DEPARTMENT OF FOOD SCIENCE & NUTRITION**

BACHELOR OF FOOD SCIENCE AND TECHNOLOGY

**FOOD ENGINEERING
AGF 4210**

2021/2022 END OF YEAR EXAMINATIONS

11th November, 2022.

DURATION: THREE (3) HOURS

VENUE: OTHER ROOMS

INSTRUCTIONS TO THE CANDIDATES:

1. PLEASE READ THE INSTRUCTIONS AND EACH QUESTION CAREFULLY.
2. THIS PAPER HAS SECTION A & B AND CONTAINS 6 QUESTIONS
3. ANSWER ANY 2 QUESTIONS FROM SECTION A AND ANY 2 FROM SECTION B
4. EACH QUESTION CARRIES 25 MARKS.

SECTION A (ANSWER ANY 2)

1.
 - a) Briefly outline two problems that commonly affect the quality of powdered products during storage and transportation. **(6 marks)**
 - b) Describe in details how you would maintain the integrity of powdered milk product during storage and transportation **(8 marks)**
 - c) What is glass transition temperature and why is it important in the storage and transportation of powders? **(5 marks)**
 - d) Describe the principle governing the separation of crude food materials using the following physical techniques:
 - i. Centrifugation **(4 marks)**
 - ii. Sedimentation **(2 marks)**

2. Skim milk is prepared by the removal of some of the fat from whole milk. This milk is found to contain 90.5% water, 3.5% protein, 5.1% carbohydrate, 0.1% fat and 0.8% ash. If the original milk contained 4.5% fat. *Whole milk amount?*
 - a) Draw and clearly label the process flow diagram. **(5 marks)**
 - b) Calculate its composition assuming that fat only was removed to make the skim milk and that there are no losses during processing. **(17 marks)**
 - c) Give three examples of unit operations in Food Engineering. **(3 marks)**

3. A large storage tank contains sunflower oil with a density of 917kg/m^3 . The tank is 3.66 m tall and is vented (open) to the atmospheric pressures of 1 atm at the top. The tank is filled with oil to a depth of 3.05 m and also contains 0.61 m of water at the bottom on which an oil layer floats. $1\text{ atm} = 1.01325 \times 10^5\text{ Pa}$
 - a) Calculate in Pa,
 - i. The pressure at a point 3.05 m from the top of the tank. **(3 marks)**
 - ii. The pressure at the bottom of the tank. **(3.5 marks)**
 - iii. The gauge pressure at the bottom of the tank. **(3.5 marks)**
 - b) Define pseudoplastic fluids and give one example of a food product **(5 marks)**
 - c) Reynolds number is very important in determining the flow type in fluid flow. This number has dimensions. YES or NO, clearly elaborate. **(10 marks)**

SECTION B (ANSWER ANY 2)

4. A newly formed food company is interested in knowing the manufacturing process of oil from soybeans. As a food technologist, can you explain in detail what processes are involved in the processing of cooking oil from soybeans? **(25 Marks)**
- 5.
- a) Discuss in detail crystallization and its importance in the food industry. **(15 Marks)**
 - b) Why is the drying process important and how can you obtain a drying curve for a food product? **(10 Marks)**
6. A continuous single-effect evaporator concentrates 9072 kg/h of a 1.0 wt % salt solution entering at 311.0 K (37.8 °C) to a final concentration of 1.5 wt %. The vapor space of the evaporator is at 101.325 kPa (1.0 atm abs) and the steam supplied is saturated at 143.3 kPa. The overall coefficient $U = 1704 \text{ W/m}^2 \cdot \text{K}$.
- a) Draw a schematic diagram for the single effect evaporation system. Show the main components of this unit. **(5 marks)**
 - b) calculate the amounts of vapor and liquid product this unit. **(10 marks)**
 - c) Calculate the heat-transfer area required for this unit. Assumed that, since it its dilute, the solution has the same boiling point as water. **(10 marks)**

END OF EXAMINATION

THE UNIVERSITY OF ZAMBIA
SCHOOL OF AGRICULTURAL SCIENCES
DEPARTMENT OF FOOD SCIENCE AND NUTRITION
2021_2022 ACADEMIC YEAR
FINAL EXAMINATION
June 2022
AGF4221 PROCESS CONTROL AND INSTRUMENTATION

TIME ALLOWED: **THREE HOURS (3 hours)**

INSTRUCTIONS:

This paper has **SIX (6)** questions. Each question carries **20 marks**

ANSWER ANY FIVE (5) QUESTIONS

In order to get full marks, it is desirable to show the method of calculation and the steps taken to achieve the results.

QUESTION 1

- (a) Given a stirred tank heating system (Figure 1), describe with the aid of a sketch how the height of the liquid in the tank can be maintained at a desired value of h_d using a control system. **[8 marks]**

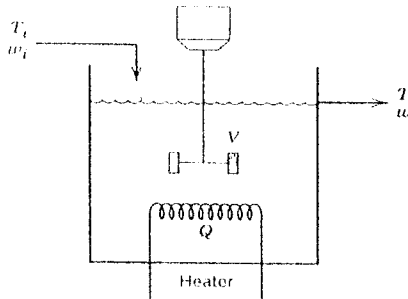

Figure 1. Stirred-Tank Heating Process

- (b) With the help of sketches, write notes on the following control configurations
- i. Feedback Control **[4 marks]**
 - ii. Feed forward Control **[4 marks]**
 - iii. Inferential Control Scheme **[4 marks]**

QUESTION 2

- (a) Write notes on the following classes of process models including their advantages and disadvantages:

- i. Theoretical model **[4 marks]**
- ii. Empirical model **[4 marks]**

- (b) The total mass balance equation for a Liquid Tank Heating System is given as:

$$A(dh/dt) = Fi - Fo.$$

where:

A = Cross sectional area of tank,

h = Height of liquid in the tank,

Fi = Flow rate of liquid into the tank,

Fo = Flow rate of liquid out of the tank.

If $Fo = \alpha(h)^{1/2}$, linearize the equation into an Ordinary Differential Equation so that it can be solved analytically. **[12 marks]**

QUESTION 3

Using a sketch of your choice, illustrate the hardware of a control system clearly explaining the process involved and any six (6) hardware elements and their functions in the process.

[20 marks]

QUESTION 4

You are the processing manager in a food processing factory and your company is experimenting on a new food process line. This being a new process, the staff are finding it difficult to understand the process. Explain in detail five (5) reasons you can give to convince the company to have a mathematical representation of the real system. [20 marks]

QUESTION 5

Identify the forcing functions in the following examples and give the equations and the graphs depicting the function. Q is the quantity of steam and t is the time.

- (a) Open the steam valve at $t = 0$ so that Q changes by A units, hold at the new value for the time duration of b and return to the old value. [5 marks]
- (b) Gradually open the steam valve so that Q increases linearly and then the function ends when the valve is fully open. [5 marks]
- (c) Open the steam valve at $t = 0$ so that Q changes by A units. [5 marks]
- (d) Open the steam valve and instantaneously return to the old value. [5 marks]

QUESTION 6

A beaker containing 2 liters of water is to be heated using an immersed electrical heater. There is no inflow or outflow of water. At time zero, the heater is turned on using electrical power that is converted to heat. The following temperature data are collected:

Time, (t) s	Temperature, (T) °C
0	24
500	31
1000	37
1500	43

If the dynamic model is described by Equation 6 below;

$$Q = [MC](dT/dt)$$

Equation 6

Where Q = electrical heater input, Watts,

M = mass of water in the beaker, kg,

C = specific heat capacity of water (4,200 J/kg °C);

- (a) Plot a graph of temperature against time [5 marks]
- (b) Estimate the term Q/MC from the graph [7 marks]
- (c) Calculate the electrical heater input Q in Watts. [8 marks]

*****END*****



**THE UNIVERSITY OF ZAMBIA
SCHOOL OF AGRICULTURAL SCIENCES
DEPARTMENT OF FOOD SCIENCE AND NUTRITION**

**2020/2021 ACADEMIC YEAR
FINAL EXAMINATION**

**COURSE: AGF 5071
Food Colloids**

Date: Monday, 14th February 2022

Time: 14.00 – 15.30 Hours

Duration: One and half hours

Venue: Omnia 1

INSTRUCTIONS TO CANDIDATES:

1. This paper has a total of three (3) questions and you are required to answer all the three (3) questions
 2. All marks allocated to each question are indicated at the end of each question
-

Question 1

(a) Short answer questions (maximum of two sentences each)

- i. For food emulsions, what does the abbreviation w/o mean? **(2 marks)**
- ii. State the three types of van der Waals intermolecular interactions **(2 marks)**
- iii. What is the difference between lyophilic and lyophobic colloids? **(2 marks)**
- iv. State two roles of emulsifiers in food emulsions production **(2 marks)**
- v. What is the difference between a substance with a low HLB number (3 to 6) and one with a high HLB number (8 to 18)? **(2 marks)**

(b) There are many factors or phenomena involved in destabilization of a well-prepared emulsion. State at least five factors or phenomena and briefly explain (maximum 2 sentences for each factor) how each one is involved in destabilization of emulsions? **(10 marks)**

Question 2

The rheological behavior of liquids can be defined by an empirical power law model

$$\tau = C * (\dot{\gamma})^n$$

Where τ = stress, C = consistency index, $\dot{\gamma}$ = strain and, n = the flow behaviour index. Describe the classification of liquids for the flow behavior index n when $n=1$, $n>1$ and $n<1$ **(10 marks)**

Question 3

You are a R&D officer of a food manufacturing firm in Lusaka. The marketing department has identified two liquid drinks, which they think if blended in a certain ratio, would produce a highly selling product. However, the two drinks are immiscible. The two drinks are labeled X and Y. Drink X is denser than Y. Drink Y is non-polar whereas X is polar. The blend of drink X and Y is envisaged to be sensorially liked by consumers if its blended in the ratio of X:Y – 10:1 by volume, respectively. The drink will also contain the following additives: xanthan, β -carotene, sodium caseinate, sucrose and tocopherol.

- (a) How do you propose to blend X and Y into one blended drink with its additives (propose a flow-sheet to explain your answer, give reasons for each step in the flow-sheet. **(10 marks)**
- (b) State with a reason, which liquid is likely to be the continuous phase **(2.5 marks)**
- (c) State and explain in a sentence for each, 5 important destabilizing factors of your blend **(5 marks)**
- (d) Explain the main purpose for each of the 5 additives added to the blended drink **(2.5 marks)**

End of Exam

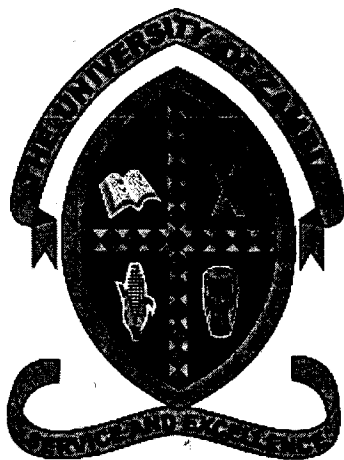

**THE UNIVERSITY OF ZAMBIA
SCHOOL OF AGRICULTURAL SCIENCES
DEPARTMENT OF FOOD SCIENCE AND NUTRITION**

**2021/2022 ACADEMIC YEAR
MID-YEAR EXAMINATION**

**COURSE: AGF 5071
Food Colloids**

Date: Wednesday, 15th June 2022

Time: 14.00 – 15.00 Hours

Duration: THREE (3) HOURS

Venue: Omnia 2

INSTRUCTIONS TO CANDIDATES:

1. This paper has a total of **Five (5)** questions and you are required to answer all the **five (5)** questions
2. All marks allocated to each question are indicated at the end of each question

Question 1

- (a) Write short notes on the following:
- Interface and interfacial tension
 - Stability ratio of coagulation
 - Protein bridging
 - Steric stabilization in emulsions
 - Peptisation
- (b) State three (3) sources of disruptive forces for a droplet during homogenization of a primary emulsion into a secondary emulsion? Out of the three, choose one, which you can describe/explain how that disruptive force breaks up the emulsion droplet?

(10 marks, 2 marks each)

(10 marks)

Question 2

- (a) Briefly discuss the concept of gelation with reference to three (3) modes of gel formation.
- (b) What are viscoelastic materials? In your definition, give an example
- (c) What is the difference between plastic and viscoelastic materials?
- (d) The graphs (a) and (b) describe the surface charges of charged surfaces under different conditions. Explain the circumstance(s) that could lead to the surface potential (potential of the charged surface) to vary as described in each of the two graphs

(6 marks)

(2 marks)

(2 marks)

(4 marks)

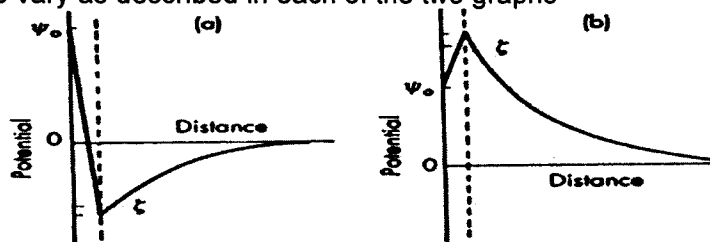

Figures (a) and (b)

- (e) What is meant by lyophobic dispersions and suggest two (2) conditions that make lyophobic dispersions stable?
- (f) When Ca^{2+} ions are added to soymilk, coagulation of the soymilk may be observed. Explain this phenomenon

(3 marks)

(3 marks)

Question 3

- (a) There are many factors or phenomena involved in destabilization of a well-prepared emulsion. State five factors or phenomena and discuss how each one is involved in the destabilization of emulsions?
- (b) (i) Define van der Waals interactions
- (ii) State and briefly explain three types of van der Waals forces
- (iii) Which of the three types is prominent and why?

(10 marks)

(2 marks)

(6 marks)

(2 marks)

Question 4

- (a) Explain the behavior of proteins at a water-in-oil interface in relation to their conformation state. Support your answer by a diagram (s).
- (b) Surfactants aggregate spontaneously in solution to form a variety of thermodynamically stable structures known as association colloids. A common example of association colloids is a micelle. Associated with the micelle is the Critical Micelle Concentration (CMC). Explain and discuss the CMC concept including the effects of a surface-active compound on the properties of a solution below the CMC, at CMC and above the CMC.

(10 marks)

(10 marks)

Question 5

Assume two droplets at such a large distance apart such that their interaction is at very minimum. Describe the process of coagulation between the two droplets in an emulsion using the DLVO theory.

(20 marks)

----- End of Exam -----

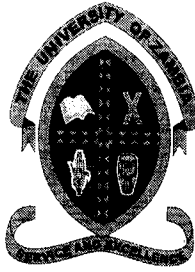

**THE UNIVERSITY OF ZAMBIA
SCHOOL OF AGRICULTURAL SCIENCES
DEPARTMENT OF FOOD SCIENCE & NUTRITION**

2021/22 ACADEMIC YEAR FINAL EXAMINATIONS

**AGF 5321
Technology of Dairy & Egg products**

Date: Thursday 23rd June 2022

Time: 09:00hrs

Venue: OMNIA 1 Lecture Theatre

Duration: THREE (3) HOURS

INSTRUCTIONS TO THE CANDIDATES:

- 1. THIS PAPER CARRIES 100 MARKS AND HAS TWO (2) SECTIONS.**
- 2. ANSWER ALL QUESTIONS IN SECTION 1 AND SECTION 2.**
- 3. ANSWER THE TWO SECTIONS IN SEPARATE ANSWER BOOKLETS.**
- 4. ALLOCATED MARKS FOR EACH QUESTION ARE INDICATED IN BRACKETS.**

5. Name with values the characteristics of egg oil.

[4 marks]

6. Briefly describe how to determine the following:

- a. pH
- b. Ash
- c. α – amylase

For each of the above descriptions, explain the significance of the test in egg technology.

[2 marks for each]

End of Examination!!

SECTION 1: Technology of Dairy Products

1. The Manager of Mapepe Dairy Cooperative approaches you for assistance on diversifying their production from set yoghurt to fresh cream. As a dairy expert, you are expected to make a presentation to the Board members on the viability of this project.
 - a. Explain with aid of a flow diagram, the manufacturing process of fresh cream. [15 marks]
 - b. State the changes (including new equipment) that should be made to the existing production line in order to produce the new product as well as butter. [4 marks]
 - c. Would you support this diversification plan? Give reasons. [1 marks]

2. Tamuke Dairy Products Company is involved in the manufacture of yoghurt. The company's technical manager approaches you with a problem of bulging packs after a few days of storage.
 - a. Explain the possible causes of the problem. [4 marks]
 - b. Give the possible solutions and offer recommendations. [3 marks]
 - c. Discuss the difference between pasteurised and sterilised milk. [6 marks]
 - d. Explain the principle of cheese ripening and give an example of ripened cheese. [4 marks]
 - e. Give three (3) function(s) of starter cultures. [3 marks]

3. For each of the following:
 - a. Explain the importance of aging and freezing in ice-cream making. [6 marks]
 - b. Describe and illustrate the structure of the casein micelle. [6 marks]
 - c. Illustrate the process of UHT milk making. [6 marks]
 - d. Discuss the difference between hydrolytic and oxidative rancidity. [2 marks]

SECTION 2: Technology of Eggs – Answer all questions in a separate booklet.

1. Mention and briefly describe 2 non-food uses of eggs. [2 marks]

2. Describe with aid of a diagram, the formation of the egg as it moves from the mouth of the oviduct, through the oviduct and the laying systematically of different constituents which make up the egg shell. Further describe possible defects that may occur as the egg travels through the oviduct. [18 marks]

3. Describe the four storage methods aimed at prolonging the shelf life of table eggs. [6 marks]

4. Why are eggs not pasteurized at the same the temperature as that of milk? [4 marks]

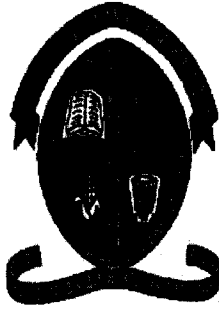

**THE UNIVERSITY OF ZAMBIA
SCHOOL OF AGRICULTURAL SCIENCES
DEPARTMENT OF FOOD SCIENCE AND NUTRITION**

2022 ACADEMIC YEAR – FINAL EXAMINATIONS

**COURSE: AGF 5432
Food Safety and Quality Management**

Date: Monday, 31st October 2022

Time: 09.00 – 12.00 Hours

Duration: THREE (3) HOURS

Venue: FSN 2

INSTRUCTIONS TO CANDIDATES:

1. There are five (5) questions in this examination paper.
2. **Answer all questions in this examination paper**
3. Each question carries 20 marks giving a total of 100 marks for this examination paper
4. The marks allocated are given at the end of each question.

Questions 1

a) What do you understand by the following terms in food safety and quality management:

- i. Codex Alimentarius Commission **[2 marks]**
- ii. Integrated food chain surveillance **[2 marks]**
- iii. Food safety **[2 marks]**
- iv. Precautionary principle in the SPS Agreement **[2 marks]**
- v. Legal metrology **[2 marks]**

b) Answer the following questions (brief answers):

- i. State two main food safety related Acts (Zambians Laws) in the Zambian Food Safety System and briefly state their main objective in relation to food safety **[2 marks]**
- ii. State two Zambian and two international incidents that exemplify food safety crisis **[2 marks]**
- iii. The table below shows three-class attribute plans for ice cream according to the Canadian sampling plans.

Product	Organisms	Plan class	N	m (cfu/g)	M (cfu/g)	c	Source
Ice cream	APC	3	5	10 ⁵	10 ⁶	2	Canada
	Coliforms	3	5	10	10 ³	1	

Five (5) samples from a batch of ice cream were analyzed for Aerobic Plate Count (APC) and the following results were obtained:

Sample 1: 105,000 cfu/g; **Sample 2:** 99,000 cfu/g; **Sample 3:** 101,000 cfu/g; **Sample 4:** 200,000 cfu/g; and **Sample 5:** 80,000 cfu/g.

Would you accept or reject the batch of ice cream? Explain your answer **[2 marks]**

- iv. State one advantage and disadvantage of each, for the passive and active surveillances **[2 marks]**
- v. What is the difference between microbiological standard and specification **[2 marks]**

QUESTION 2

A medium sized food processing company approaches you with a view to develop a HACCP plan for its growing company. With an assumption that the company has already conducted the preliminary stages, state the seven (7) core principles or stages of a HACCP plan and explain on what is involved in implementing the seven steps for their company. **[20 marks]**

QUESTION 3

There are eight broad areas covered by the Codex General Principles of Food Hygiene promulgated by the Codex Alimentarius Commission, that require practical implementation to achieve GMPs in a food chain of a given food sector or food industry.

- (a) Apart from that already stated in 3(b) below, state any other five (5) of the broad areas that a food chain needs to implement to ensure GMPs **[5 marks]**
- (b) One of the important specific areas among the eight broad areas is the Control of Operations in the food chain. Mention five (5) important broader aspects of the Control of Operations that are important in ensuring GMPs in an establishment. Briefly, explain each of the five aspects with an aid of an example for each. **[15 marks]**

QUESTION 4

Risk analysis in food safety is defined by three major components. One of the components, which is a scientific component, is risk assessment and involves different stages in conducting such an assessment.

- a) State and very briefly explain the other two components of risk analysis in food safety **[5 marks]**
- b) State and explain the stages involved in conducting a chemical risk assessment **[15 marks]**

QUESTION 5

A Zambian small-to-medium enterprise (SME) is involved in processing juices. The SME imports fruit juice concentrates, which are processed into ready-to-drink juices. The SME is interested in implementing a quality management system in their establishment. You as an Intern at Zambia Bureau of Standards has been requested by your Supervisor to explain the quality management system based on the process approach of the plan-do-check-act (PDCA) cycle or framework. To do this, your supervisor has asked you to write down the following before the SME comes for explanation, to ensure that you will explain the right things:

- (i) Write down the framework of the PDCA cycle without explaining it **[5 marks]**
- (ii) To ensure the SME makes a decision on whether to implement or not implement the quality management system, your supervisor wants you to explain two important factors that the SME must consider. The factors important to the implementation of the quality management system can be split into two major sets of factors, namely, those that are external to the organization and those that are internal to the organization. State and briefly explain (max. 2 sentences for each) each of the factors that are external to the organization and those that are internal to the organization, that the SME should consider **[13 marks]**
- (iii) What is the major difference between the external and internal factors with regard to the implementation of a quality management system in an organization? **[2 marks]**

END

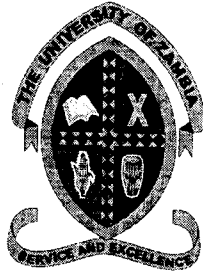

UNIVERSITY OF ZAMBIA

SCHOOL OF AGRICULTURAL SCIENCES

DEPARTMENT OF FOOD SCIENCE AND TECHNOLOGY

2022

FINAL EXAMINATION

PROCESSING AND PRESERVATION OF PLANT PRODUCTS

AGF 5615

DATE: 13th June, 2022

TIME: 09.00 – 12.00 HRS

VENUE: FSN 1

INSTRUCTIONS:

1. Students are **NOT permitted** to bring mobile phones and/or any other unauthorized electronic devices or other materials into the examination room.
2. Write your **student number** in the space provided on the answer booklet.
3. Answer **each section** in a separate booklet.
4. All questions carry **equal marks** and the allocated marks are shown for each question.

Section A: Answer All questions

1. Compare and contrast between the physical refining process and the chemical refining process of crude soybean oil with the aid of a flow diagram. Indicate the products and by products of each of the steps. [10 marks]

2. Write short and concise notes discussing the following (5 lines or less than).

ii) Whitening during rice processing [2 marks]

iii) Desolventizer toaster [2 marks]

iv) *Ipomoea batatas* [2 marks]

v) cereal germ [2 marks]

vi) Raffinose and stachyose [2 marks]

Section B: Answer all questions in this section

1. On processing of Beet Root and sugar cane for sugar production explain in detail the processing steps that are similar and those that are profoundly different. [20 marks]

SECTION C: Answer all questions

1. Fruit & vegetable technology section

a. Explain the manufacturing process of canned guava with aid of a flow diagram.

[18 marks]

b. Discuss the preservation principle in freezing and drying. [2 marks]

2. Food fermentation section

a. Illustrate the tempeh manufacturing process using a flow diagram. [6 marks]

b. The Manager of Moffpego Wineries Ltd approaches you with a problem of their wine white wine being discoloured (brownish colour). Explain the causes of the problem and offer possible solutions. [4 marks]

c. Explain the following in only 5 lines:

i. Malting [2 marks]

ii. Sauerkraut [2 marks]

iii. Sufu [2 marks]

iv. Beer [2 marks]

v. Hops [2 marks]

SECTION D: Answer one question of your choice in this section.

1. (a) What is Cold pressing? [3 marks]

(b) What is the role of roots and tubers in nutrition [5 marks]

(c) Legumes are classified into several classes including oilseeds (groundnut, soyabeans) and pulses or grain legumes (kidney beans, peas). What is the major differences/considerations taken into account during the postharvest handling/processing of the two classes? [4 marks]

(d) Draw a soyabean seed, labelling all the parts. [3 marks]

(e) What is the composition of soyabeans? [3 Marks]

(f) What are soyabean isoflavones?

[2 mark]

2. (a) Describe the following, in relation to sugar production

i) Maltodextrins

[3 Marks]

ii) Bagass

[3 Marks]

iii) Crystallization

[3 Marks]

(b) Name three spice producing countries in Africa.

[3 Marks]

(c) In your own words explain the significance of consuming spices currently, which was previously not much emphasized upon

[8 Marks]

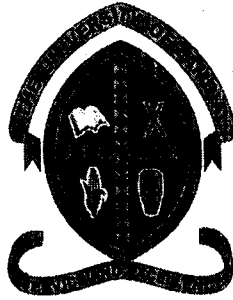

THE UNIVERSITY OF ZAMBIA
SCHOOL OF AGRICULTURAL SCIENCES
DEPARTMENT OF FOOD SCIENCE & NUTRITION

2021/22 ACADEMIC YEAR FINAL EXAMINATIONS

**AGF 5625 – PROCESSING AND PRESERVATION OF ANIMAL
PRODUCTS**

Date: 31ST OCTOBER, 2022

Venue: FSN 2

Time: 09.00 – 12.00 hrs

Instructions:

Answer **all** Sections. Each section has instructions.

Allocated marks are shown in brackets at the end of each question.

Section A: Answer any two questions

1. a) Discuss **in detail** the sliding filament theory of muscle contraction. Include diagrams to illustrate the process. **[15 marks]**
- b) List down the sensory methods that are used to evaluate the quality of fresh fish. **[5 marks]**
2. a) What factors limit the storage life of fish? **[2 marks]**
- b) Discuss the following terms in 5 lines or less (stating all the important and pertinent issues concerning the term)
 - i. Air blast freezer **[1.5 marks]**
 - ii. Fish lipids **[1.5 marks]**
 - iii. Gaspe curing **[1.5 marks]**
 - iv. K value **[1.5 marks]**
 - v. Non protein nitrogen fraction in fish **[1.5 marks]**
 - vi. Fish meal **[1.5 marks]**
- c) Discuss **in detail** the production of fish meal. **[6 marks]**
- d) What is the autolytic breakdown of trimethylamine oxide. Show the reactions that take place during this breakdown. **[4 marks]**
3. a) Ice is commonly used in preservation of fish by chilling. List the five (5) reasons why ice is used in chilling of fish. **[4 marks]**
- b) Why is the storage life of freshwater fish on ice longer than that of marine fish on ice? **[2 marks]**

c) Discuss and outline the processing of frog legs, including the pertinent issues to take care of the safety of the products

[6 marks]

d) List the factors that affect the salting processing. [2 marks]

e) Define the following terms in 5 lines or less (including all the important and pertinent issues in the definition of the term)

i. kench curing [1.5 marks]

ii. solar dryer [1.5 marks]

iii. chilled sea water [1.5 marks]

iv. plate freezer [1.5 marks]

Section B: Answer question 1 and any other question.

1. a) Name and describe four (4) methods of prolonging the shelf life of table eggs [8 marks]

b) Name and describe four (4) methods of preserving eggs that go to the industry [12 marks]

2. a) Describe what happens when there is failure of the protective mechanisms in the live animal. [10 marks]

b) Define the following

i. Exsanguination [2 marks]

ii. Myosin [2 marks]

iii. Rigor mortis [2 marks]

iv. conversion of muscle to meat [3 marks]

v. Sarcoplasm [1 mark]

3. a) Describe the chemical composition of meat **[8 marks]**
- b) Describe the significance of meat in the diet. **[4 marks]**
- c) Explain how meat colour is described using five descriptors. **[4 marks]**
- d) Name and describe the three groups of proteins found in meat. **[4 marks]**

Section C: Answer all questions.

1. Illustrate the manufacturing process of set yoghurt using a flow diagram. **[6 marks]**
2. Tabledub Dairy Products Limited approaches you with a problem of their pasteurised milk having a shelf life of only two days. State the normal shelf life of this product under refrigerated conditions and briefly discuss the possible causes and offer solutions to the problem. **[4 marks]**
3. Briefly explain the significance of cream ripening during butter making. **[2 marks]**
4. Explain the principle of cheese making using lemon juice and give the expected yield of cheese produced by this method in percentage. **[3 marks]**
5. Describe the milk reception platform tests. **[2 marks]**
6. Show the difference between commercial (lacto) & traditional tonga mabisi production using flow diagrams. **[3 marks]**



**THE UNIVERSITY OF ZAMBIA
SCHOOL OF AGRICULTURAL SCIENCES
DEPARTMENT OF FOOD SCIENCE & NUTRITION**

MSc. FOOD SCIENCE AND TECHNOLOGY

**ADVANCED FOOD ENGINEERING
AGF 6321**

2021-2022 MID YEAR EXAMINATIONS

DURATION: THREE (3) HOURS

VENUE: FSN 2

DATE: 13/06/2022

TIME: 0.9.00HRS

INSTRUCTIONS TO THE CANDIDATES:

1. PLEASE READ THE INSTRUCTIONS AND EACH QUESTION CAREFULLY.
2. THIS PAPER HAS **FOUR** QUESTIONS AND EACH CARRIES **25 MARKS**
3. ANSWER ALL QUESTIONS.

1. In the process of producing Apple juice, a fresh extracted and strained juice containing 10 wt % solids is evaporated in the first evaporator, giving 18 wt % solids in the juice. This is fed to a second evaporator, which gives 50 wt % concentrated juice as a final product.
 - a) Draw and clearly label the process flow diagram **(5 points)**
 - b) Calculate the water removal from each evaporator **(7 points)**
 - c) Calculate the amount of product produced (concentrated juice) **(7 points)**
 - d) What does the law of conservation of mass state? Is it holding in the above process? Show by performing a check either on a component or on the overall process. **(6 points)**

2.
 - a) Why is it important for Food Technologists to have knowledge in fluid flow theory? **(5 points)**
 - b) The batch and CSTR reactors are commonly used in the brewing industry. Describe each in **few words** and state their two advantages and two disadvantages **(5 points)**
 - c) Describe the scenario under constant rate filtration **(5 points)**
 - d) Sedimentation separations are commonly used in the food industry, describe the principal and give examples of practical applications **(5 points)**
 - e) List energy types that may be considered when doing energy balances in fluids using Bernoulli equation **(5 points)**

3. Olive oil is pumped from the processing room along a 170 m of 5 cm diameter horizontal steel pipe to the packaging room where it is automatically packaged into 5 Liter containers. The viscosity of olive oil at 20°C = $84 \times 10^{-3} \text{ N s m}^{-2}$ and density = 910 kg m^{-3}
 - a) Calculate the pressure drop along 170 m of 5 cm diameter horizontal steel pipe **(13 points)**
 - b) Why is viscosity important in fluid flow theory **(6 points)**
 - c) Differentiate between absolute pressure and gauge pressure. **(6 points)**

4.
 - a) How much water would be required in a jet condenser to condense the vapours from an evaporator evaporating 5000 kg h^{-1} of water under a pressure of 15 cm of mercury? The condensing water is available at 18°C and the highest allowable temperature for water discharged from the condenser is 35°C. **(10 points)**

Hint: The pressure in the evaporator is 15 cm mercury = $Z\rho g = 0.15 \times 13.6 \times 1000 \times 9.81 = 20 \text{ kPa}$.
From Steam Tables, the condensing temperature of water under pressure of 20 kPa is 60°C and the corresponding latent heat of vaporization is 2358 kJ kg⁻¹.

- b) Describe typical features of the forward feeding arrangement in the multiple effect evaporator. **(5 marks)**
- c) Using a typical drying curve, show five stages of drying? **(5 points)**
- d) Describe two size reduction operations that are commonly used in the food industry **(5 points)**

END OF THE EXAMINATION

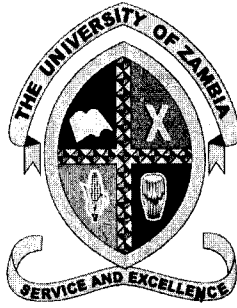

THE UNIVERSITY OF ZAMBIA
SCHOOL OF AGRICULTURAL SCIENCES
DEPARTMENT OF FOOD SCIENCE & NUTRITION

2021/2022 ACADEMIC YEAR FINAL EXAMINATIONS

**AGF 6432 – ADVANCED TECHNOLOGY OF MEAT, POULTRY
AND FISH**

Date: 11th November, 2022

Venue: FSN 3

Time: 09.00 – 12.00 hrs

Instructions:

Answer ALL sections.

All questions carry equal marks and allocated marks are shown in brackets at the end of each question.

SECTION A: Answer any two (2) questions in this section

1. a) State the advantages and disadvantages of thawing frozen blocks of fish by immersion in heated water.

[4 marks]

b) Outline and discuss the production of fish meal.

[3 marks]

c) Define the following terms in 5 lines or less (stating all the important and pertinent issues concerning the term)

i. Structural proteins **[1.5 marks]**

ii. Facultative anaerobes **[1.5 marks]**

iii. Fish meal **[1.5 marks]**

iv. K value **[1.5 marks]**

v. Hysteresis **[1.5 marks]**

v. immersion freezer **[1.5 marks]**

d) Dried fish spoils through physical, chemical and bacterial processes. Discuss the chemical spoilage of dried fish and state how the control of this form of spoilage can be used to increase the shelf life of the dried fish. **[4 marks]**

2. a) Compare and contrast between sun drying and solar tent drying of fish, describing in detail two major advantages and two disadvantages of each method. **[5 marks]**
- b) Discuss the factors that affect the salting process. **[2.5 marks]**
- c) How does slow freezing result in a frozen fish product of inferior quality. **[2.5 marks]**
- d) The preservative effect of smoking on fishery products is due to a combination of several factors. List and discuss four of these factors. **[4 marks]**
- d) Write **short** and **concise** notes on the following terms (five lines or less, stating all the important and pertinent issues concerning the term)
- i. Autolysis **[1.5 marks]**
 - ii. Quality Index method **[1.5 marks]**
 - i. Actin and myosin **[1.5 marks]**
 - ii. Kench curing **[1.5 marks]**

3. a) The methods for evaluation of fresh fish quality may be conveniently divided into two categories: sensory and instrumental methods. The instrumental methods include the biochemical and chemical, the physical and the microbiological methods. Discuss these methods of assessment of fish quality in detail. **[14 marks]**

b) Write **short** and **concise** notes on the following terms (five lines or less, stating all the important and pertinent issues concerning the term)

- i. Calpains **[1.5 marks]**
- ii. Solar salt **[1.5 marks]**
- iii. Champagne method **[1.5 marks]**
- iv. Molluscs **[1.5 marks]**

SECTION B Answer All questions

QUESTION 1

(i) Define the following terms:

- (a) Rigor mortis **[2 marks]**
- (b) PSE meat **[2 marks]**
- (c) Marbling **[2 marks]**
- (d) Cold shortening **[2 marks]**
- (e) Yield grading **[2 marks]**

(ii) Describe the structure of the myofibril? **[10 marks]**

QUESTION 2

Nitrates are usually used in the production of cured meats. One of their major functions in cured meats is to impart a characteristic colour to the cured meat. Describe and discuss the four (4) major stages or steps of the chemistry of the cured meat colour due to the use of nitrates. **[20 marks]**

Section C

Answer all questions in this section

Question 1

- a. Define zoonosis. **[2 marks]**
- b. Identify two (2) human activities and describe how they accelerate the emergence and re-emergence of zoonotic pathogens. **[4 marks]**
- c. List two (2) different ways people can get zoonotic diseases **[2 marks]**
- d. List two (2) zoonotic pathogens of public health significance that are transmitted through unpasteurized milk **[1 mark]**
- e. Define antibiotic resistance and explain how antibiotic resistance in foodborne pathogens is a threat to human health **[5 marks]**
- f. Identify and discuss one (1) way of reducing public health risks from zoonotic diseases and other health threats at the human-animal-ecosystem interface. **[2 marks]**
- g. What is biosecurity, and why is it important in the prevention of zoonoses. **[4 marks]**

END OF EXAMINATION

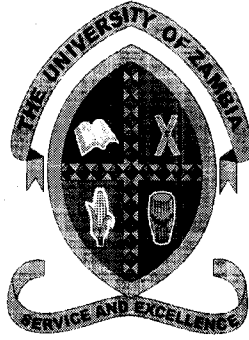

**THE UNIVERSITY OF ZAMBIA
SCHOOL OF AGRICULTURAL SCIENCES
DEPARTMENT OF FOOD SCIENCE & NUTRITION**

**2021/22 ACADEMIC YEAR END OF YEAR FINAL
EXAMINATIONS**

**AGF 6442
Advanced Technology of Fruits & Vegetables**

Date: Thursday 17th November 2022

Time: 09:00hrs

Venue: FSN 3 Lecture Room

Duration: THREE (3) HOURS

INSTRUCTIONS TO THE CANDIDATES:

- 1. THIS PAPER CARRIES 100 MARKS.**
- 2. ANSWER ALL QUESTIONS.**
- 3. ALLOCATED MARKS FOR EACH QUESTION ARE INDICATED IN BRACKETS.**

Answer all questions

Question 1

- a) Explain the production process of dried potato powder with aid of a flow diagram. [20 marks]
- b) A client approaches you with a problem of their fresh peeled potatoes undergoing discolouration after a short storage period. Diagnose the problem and offer possible solutions. [5 marks]

Question 2

- a) Explain the natural production process of sauerkraut with aid of a flow diagram. [15 marks]
- b) How would you modify this production process to direct acidification? [4 marks]
- c) Give the advantages and disadvantages of natural and direct acidification. [6 marks]

Question 3

- a) Discuss three (3) different types of freezers and give an example of the kind of product that is suited for each type. [12 marks]
- b) HBM frozen foods approaches you with a problem of frequent incidences of freezer burn in their frozen peas. Diagnose the problem and offer possible solutions. [8 marks]
- c) Explain the difference between sun and solar drying. [5marks]

Question 4

- a) Concentration is an important preservation technique.
- Briefly explain its principle [3 marks]
 - Give two examples of products that are preserved through concentration [2 marks]
 - Illustrate the production process of one of these products [8 marks]
 - State two parameters you would test at the end of the production process of this product and give reasons. [4 marks]
- b) Briefly explain the significance of can exhausting and sterilization in canning. [8 marks]

End of Examination

THE UNIVERSITY OF ZAMBIA

**UNIVERSITY SUPPLEMENTARY AND DEFERRED
EXAMINATIONS – 2020/21**

AGG 3811 (RURAL SOCIOLOGY)

TIME: 2 Hours

Marks: 100

**INSTRUCTIONS: ANSWER ALL QUESTIONS AND WRITE
LEGIBLY**

QUESTIONS

1. “Social stratification is a tool used to rank people in layers.”
 - a) Using Emile Durkheim’s perspective, discuss the extent to which social stratification represents an inevitable tool to forging societal stability (10 marks).
 - b) With cited examples, explain how Karl Marx’s views on social stratification differs from Durkheim’s (10 marks)
2. Clearly state at least two significant roles that following identified “socializers” play in lives of Zambian people:
 - a) School (5marks), b) Peers (5marks), c) Mass media (5marks) d) Family (5 marks)
3. Explain the definitional differences between the following concepts:
 - a) Sacred and secular association (4 marks)
 - b) Mechanical and organic solidarity (4 marks)
 - c) Social stratification and social change (4 marks)
 - d) Rationalization and formalization (4 marks)
 - e) Rural and urban societies (4 marks)
4. The family is defined as ‘a kinship grouping which provides for the rearing of children and for certain other human needs.’
 - a) State the differences between nuclear and extended family and between monogamous and polygamous forms of marriages (8 marks)
 - b) Briefly describe any **FOUR** functions of the family (8 marks)
 - c) Explain at least **two** known cultural threats that mass media poses on the current Zambian families (4marks).
5. “Traditional, Charismatic and bureaucracy constitute three main forms of authority.”
 - a) Describe each one of these forms of authority (12 marks)
 - b) Provide advantages and disadvantages of traditional and charismatic authority (6 marks)
 - c) State reasons why bureaucracy is a more superior form of authority (4 marks)

..... END.....

THE UNIVERSITY OF ZAMBIA
UNIVERSITY DEFERRED AND SUPPLEMENTAY EXAMINATIONS
2020/21 ACADEMIC YEAR

AGG 3822 (AGRICULTURAL EXTENSION)

TIME: 2 HOURS

MARKS: 100

INSTRUCTIONS: ANSWER ALL QUESTIONS AND WRITE LEGIBLY

QUESTIONS

1. State major differences between Rural Development Programmes and Commodity Development Approach suggesting improved ways to assisting farming communities in Zambia (20 marks).
2. Define the term diffusion and state the major roles the three elements play in the diffusion of innovation process (20 marks).
3. With aid of a diagram, outline and clearly explain any five steps of an extension program planning process (20 marks).
4. Write short notes on the following concepts: (20 marks)
 - a) Informal organization (5 marks)
 - b) Adoption process (5 marks)
 - c) Participatory Extension Approach (5 marks)
 - d) Mass communication (5 marks)
5. Explain the term extension training method and based on two classified methods discuss its associated merits and demerits (20 marks).

..... **END OF EXAM.**.....

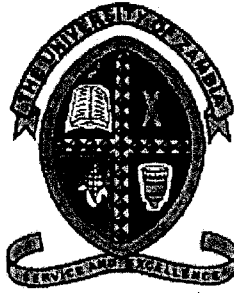

THE UNIVERSITY OF ZAMBIA
SCHOOL OF AGRICULTURAL SCIENCES

2021/2022 END OF YEAR EXAMINATIONS

COURSE : AGG 3832 FORAGE CROP PRODUCTION AND RANGE
MANAGEMENT
DATE : 11TH NOVEMBER 2022 14:00 HOURS
DURATION : THREE HOURS
INSTRUCTIONS : ANSWER ANY FIVE QUESTIONS

Question 1

Differentiate between zero grazing and rotational grazing

[20 marks]

Total [20marks]

Question 2

In range management it is important to carry out a natural resource inventory

- a) In natural resource inventory mention the six types of plant attributes that are commonly measured. (6 marks).
- b) The following data of two desirable browse species Moringa and Leucaena was collected from 12 quadrants from grazing area in Central Province. Each quadrant was 10 meters x 10 meters

Quadrant No.	1	2	3	4	5	6	7	8	9	10	11	12
Number of moringa plants	2	0	5	3	11	0	1	12	0	3	9	4
Number of Leucaena plants	3	1	1	0	0	0	2	0	0	1	0	1

- i) Calculate
The frequency of moringa and of Leucaena [8 marks]
- ii) Which of the two has better results in terms of frequency [6 marks].

Total 20 marks]

Question 3

Pasture grasses and legumes are an importance component of the ecosystem in grazing lands.

- a) Give examples of three pasture grasses and two pasture legumes. Please indicate their scientific names as well. [5mark].
- b) Outline five differences between pasture grasses and legumes. [10mark]
- c) Discuss the benefits of having grass/legumes mixture in grazing lands compared to pure grass or pure legume stands? [5mark]

Total [20marks]

Question 4

Rangelands have been neglected for a long time in programmes concerning agricultural development although they are very importance as sources of livelihoods for the local people?

- a) Describe are the characteristics of range lands? [4 marks]
- b) Mention products of economic importance that can be derived from rangelands. [6 marks].
- c) Outline the causes of land degradation in these rangelands? [4 marks].
- d) Describe the management practices that should be carried out to conserve and improve the productivity of the rangelands? [6 marks].

Total [20marks]

Question 5

A farmer in Chisamba has the following herd of cattle 6 Angoni bulls, 150 Angoni Cows and 10 Angoni heifers. He has 10 hectares of field crops, 30 hectares of citrus fruits, 900 hectares of natural grazing land. **Take 1 Livestock Unit to 5 hectares**

- a) How much grazing land does the farmer need?. [15 marks].
- b) Explain what the farmer would need to do if he had only 250 hectares of land to keep the same number of animals [5 marks].

Total [20marks]

Question 6

Hay is the oldest, and still the most important, conserved fodder, despite its dependence on suitable weather at harvest time. Meeting the feed requirements of each class of cattle is important in producing productive and healthy livestock. To do this, you need to understand both the feed requirements of your cattle as well as the value of the available feed.

- a) Outline the procedure of hay making. [12 marks].
- b) Explain how you would tell the difference between good and bad hay [8 marks].

Question 7

Energy flows through the ecosystem via food webs, they are arranged by feeding levels.

- a) Define an ecosystem. [5 marks]
 b) Describe the components of an ecosystem in rangelands? [8 marks].
 c) What are ecosystem goods and services. Explain and give examples. [7marks]

Total [20marks]

Question 8

- a) Outline the different stages of pasture growth and development. [15 marks]
 b) Explain which stage is the best for feeding animals. [5 marks]

Total [20marks]

Livestock Units of Different Breeds of Cattle

Breed	Cow	Bull	2-3 Years	1-2 Years	5-11 Months	0-5 Months
Brahman, Simmental	1.5	1.8	1.5	0.8	0.4	0.2
Hereford, Sussex, South Devon	1.3	1.6	1.3	0.7	0.3	0.2
Africander, Boran, Friesian	1.2	1.4	1.2	0.6	0.3	0.2
Barotse, Gurnsey	1.0	1.2	1.0	0.5	0.3	0.1
Tonga, Angoni, Jersey	0.9	1.1	0.9	0.5	0.2	0.1

THE END



THE UNIVERSITY OF ZAMBIA
UNIVERSITY EXAMINATIONS – FEBRUARY 2022

AGG 3842
INTRODUCTORY STATISTICS FOR AGRICULTURE

TIME: 2 Hrs.

Marks: 100

INSTRUCTIONS: ANSWER ANY THREE (☛) QUESTIONS AND WRITE LEGIBLY
ANY STATISTICAL TEST SHOULD BE AT 5% SIGNIFICANCY LEVEL

Question One (1)

- Distinguish clearly between Discrete Random Variables and Continuous Random Variables (6 Marks)
- List and describe (briefly) the 5 steps involved in carrying out a statistical investigation (10 Marks)
- Distinguish between Probability sampling methods and Non-probability sampling methods (6 Marks)
- List and describe 3 probability sampling methods (8 Marks)

Question Two (2)

The average yield of a maize variety in one ha field in Kaoma is 100 tonnes. You believe this may not be the case currently.. You pick a random sample of 5 fields and record the following yields:

119	100	125	89	70
-----	-----	-----	----	----

- Is there enough evidence to suggest the average yield in Kaoma has changed? (20 Marks)
- What does the Central Limit Theorem state and why is it important in the field of Statistics? (10 Marks)

Question Three (3)

A student in Animal Science wanted to compare four sources of diet protein. He selected day old chicks and divided them into four groups: A, B. Group A was fed a diet which had fish meal as a source of protein, Group B was fed a diet which had cotton seed cake, Group C had soya bean cake and Group D had sunflower cake as a source of protein. Weight gain was recorded as shown below:

Fish meal	Cotton seed cake	Soya bean cake	Sunflower cake
8	2	3	2
9	4	5	2
6	3	4	-1
7	5	2	0
3	1	3	3

- a) Are there significant differences among the four diets? (17Marks)
b) Which diet would you likely recommend and why?(3 Marks)

Question Four (4)

- a) In your own words, describe what you think Hypothesis Testing is and what is its significance (5 Marks)
b) Distinguish clearly between the main attributes of T-test and Analysis of variance (5 Marks)
c) Why do you think probability statistics is of importance to Research? (5 Marks)
d) List and briefly describe 4 numerical summaries you would use to describe your collected data (5 Marks)

END OF EXAMINATION



THE UNIVERSITY OF ZAMBIA
UNIVERSITY EXAMINATIONS – NOVEMBER, 2022

AGG 3842
INTRODUCTORY STATISTICS FOR AGRICULTURE

TIME: 3 Hrs.

Marks: 100

INSTRUCTIONS: ANSWER ALL QUESTIONS AND WRITE LEGIBLY
ANY STATISTICAL TEST SHOULD BE AT 5% SIGNIFICANCY LEVEL

Question One (1)

- Distinguish clearly between Discrete Random Variables and Continuous Random Variables (5 Marks)
- List and describe (briefly) the 5 steps involved in carrying out a statistical investigation (5 Marks)
- Distinguish between Probability sampling methods and Non-probability sampling methods (4Marks)
- List and describe 3 probability sampling methods (6 Marks)

Question Two (2)

At the University of Zambia, School of Agricultural Sciences research field station, you are employed as a statistician. You find that two out of every ten births from the beef herd has a genetic anomaly.

- If you randomly select 10 calves, what would be the expected number of calves with genetic anomalies? (5 Marks)
- Out of 5 randomly selected calves, what is the probability of observing at most one genetic anomaly? (5 Marks)
- Differentiate between Binomial and Poisson distributions, and state 2 characteristics of each. (5 Marks)
- Briefly describe a practical example of how you would use the binomial distribution 'for your respective majors'. (5 Marks)

Question Three (3)

Random samples of 10 observations of one year growth weight (Kg) of Boran cattle were recorded as:

106, 104, 101, 98, 110, 93, 117, 91, 108, 98.

- Is there enough evidence to suggest the data came from a distribution with mean/ average growth weight value of 100 kg? **(10 Marks)**
- Why is the Central Limit Theorem important in the field of Statistics? **(4 Marks)**
- What is the main difference between a **Z** (standard normal) distribution and **T**- distribution with regards their application? Why are these distributions of importance in the field of Statistics **(6 Marks)**

Question Four (4)

A student in Animal Science wanted to compare 5 sources of diet protein. He selected day old chicks and divided them into 5 groups: A, B, C, D and E. Observed values were as follows:

A	B	C	D	E
37	29	49	40	50
40	33	47	38	46
46	34		42	49
	31		39	
			41	

- Are there significant differences among the 5 diets? **(16Marks)**
- Which diet would you likely recommend and why?**(2 Marks)**
- If there are any differences in the diet, what method(s) would you use to determine which groups are different? **(2 Marks)**

Question Five (5)

- In your own words, briefly describe what you think Hypothesis Testing is and what is its significance **(5 Marks)**
- Distinguish clearly between the main attributes of T-test and Analysis of variance **(5 Marks)**
- Why do you think probability statistics is of importance to Research? **(5 Marks)**
- List and briefly describe 4 numerical summaries you would use to describe your collected data **(5 Marks)**

END OF EXAMINATION

CRITICAL VALUES for the "F" Distribution, ALPHA = .05.

Denominator DF	Numerator DF									
	1	2	3	4	5	6	7	8	9	10
1	161.448	199.500	215.707	224.583	230.162	233.986	236.768	238.883	240.543	241.882
2	18.513	19.000	19.164	19.247	19.296	19.330	19.353	19.371	19.385	19.396
3	10.128	9.552	9.277	9.117	9.013	8.941	8.887	8.845	8.812	8.786
4	7.709	6.944	6.591	6.388	6.256	6.163	6.094	6.041	5.999	5.964
5	6.608	5.786	5.409	5.192	5.050	4.950	4.876	4.818	4.772	4.735
6	5.987	5.143	4.757	4.534	4.387	4.284	4.207	4.147	4.099	4.060
7	5.591	4.737	4.347	4.120	3.972	3.866	3.787	3.726	3.677	3.637
8	5.318	4.459	4.066	3.838	3.687	3.581	3.500	3.438	3.388	3.347
9	5.117	4.256	3.863	3.633	3.482	3.374	3.293	3.230	3.179	3.137
10	4.965	4.103	3.708	3.478	3.326	3.217	3.135	3.072	3.020	2.978
11	4.844	3.982	3.587	3.357	3.204	3.095	3.012	2.948	2.896	2.854
12	4.747	3.885	3.490	3.259	3.106	2.996	2.913	2.849	2.796	2.753
13	4.667	3.806	3.411	3.179	3.025	2.915	2.832	2.767	2.714	2.671
14	4.600	3.739	3.344	3.112	2.958	2.848	2.764	2.699	2.646	2.602
15	4.543	3.682	3.287	3.056	2.901	2.790	2.707	2.641	2.588	2.544
16	4.494	3.634	3.239	3.007	2.852	2.741	2.657	2.591	2.538	2.494
17	4.451	3.592	3.197	2.965	2.810	2.699	2.614	2.548	2.494	2.450
18	4.414	3.555	3.160	2.928	2.773	2.661	2.577	2.510	2.456	2.412
19	4.381	3.522	3.127	2.895	2.740	2.628	2.544	2.477	2.423	2.378
20	4.351	3.493	3.098	2.866	2.711	2.599	2.514	2.447	2.393	2.348
21	4.325	3.467	3.072	2.840	2.685	2.573	2.488	2.420	2.366	2.321
22	4.301	3.443	3.049	2.817	2.661	2.549	2.464	2.397	2.342	2.297
23	4.279	3.422	3.028	2.796	2.640	2.528	2.442	2.375	2.320	2.275
24	4.260	3.403	3.009	2.776	2.621	2.508	2.423	2.355	2.300	2.255
25	4.242	3.385	2.991	2.759	2.603	2.490	2.405	2.337	2.282	2.236
26	4.225	3.369	2.975	2.743	2.587	2.474	2.388	2.321	2.265	2.220
27	4.210	3.354	2.960	2.728	2.572	2.459	2.373	2.305	2.250	2.204
28	4.196	3.340	2.947	2.714	2.558	2.445	2.359	2.291	2.236	2.190
29	4.183	3.328	2.934	2.701	2.545	2.432	2.346	2.278	2.223	2.177
30	4.171	3.316	2.922	2.690	2.534	2.421	2.334	2.266	2.211	2.165
31	4.160	3.305	2.911	2.679	2.523	2.409	2.323	2.255	2.199	2.153
32	4.149	3.295	2.901	2.668	2.512	2.399	2.313	2.244	2.189	2.142
33	4.139	3.285	2.892	2.659	2.503	2.389	2.303	2.235	2.179	2.133
34	4.130	3.276	2.883	2.650	2.494	2.380	2.294	2.225	2.170	2.123
35	4.121	3.267	2.874	2.641	2.485	2.372	2.285	2.217	2.161	2.114
36	4.113	3.259	2.866	2.634	2.477	2.364	2.277	2.209	2.153	2.106
37	4.105	3.252	2.859	2.626	2.470	2.356	2.270	2.201	2.145	2.098
38	4.098	3.245	2.852	2.619	2.463	2.349	2.262	2.194	2.138	2.091
39	4.091	3.238	2.845	2.612	2.456	2.342	2.255	2.187	2.131	2.084
40	4.085	3.232	2.839	2.606	2.449	2.336	2.249	2.180	2.124	2.077
41	4.079	3.226	2.833	2.600	2.443	2.330	2.243	2.174	2.118	2.071
42	4.073	3.220	2.827	2.594	2.438	2.324	2.237	2.168	2.112	2.065
43	4.067	3.214	2.822	2.589	2.432	2.318	2.232	2.163	2.106	2.059
44	4.062	3.209	2.816	2.584	2.427	2.313	2.226	2.157	2.101	2.054
45	4.057	3.204	2.812	2.579	2.422	2.308	2.221	2.152	2.096	2.049
46	4.052	3.200	2.807	2.574	2.417	2.304	2.216	2.147	2.091	2.044
47	4.047	3.195	2.802	2.570	2.413	2.299	2.212	2.143	2.086	2.039
48	4.043	3.191	2.798	2.565	2.409	2.295	2.207	2.138	2.082	2.035
49	4.038	3.187	2.794	2.561	2.404	2.290	2.203	2.134	2.077	2.030
50	4.034	3.183	2.790	2.557	2.400	2.286	2.199	2.130	2.073	2.026



THE UNIVERSITY OF ZAMBIA

UNIVERSITY EXAMINATIONS: DEFFERED/SUPPLIMENTRY EXAM – FEBRUARY 2022

AGG 4851

EXPERIMENTAL DESIGN AND STATISTICAL ANALYSIS

TIME: 1 and Half Hours

Marks: 74

INSTRUCTIONS: ANSWER ALL QUESTIONS AND WRITE LEGIBLY.
FOR STATISTICAL TEST USE 5% LEVEL OF SIGNIFICANCY

Question One (1)

The Minister of Agriculture would like to introduce a new variety of sorghum, to replace the local variety, which would be suitable for the changing climate. The new variety is intended to be used in the whole country. Two new varieties were imported from International Institute for Tropical Agriculture (IITA), namely, IITA-S1 and IITA-S2. One of the officers from Mount Makulu carried the research, taking into consideration the three Agro-Ecological Zones (AE-Zone) of Zambia. The Minister asked you (a 4th Year Student) to analyse the following data which was collected by the officer from Mount Makulu.

AE- Zone	Yield of Sorghum Varieties (50 kg bags per plot)		
	LOCAL	IITA-S1	IITA-S2
1	30	35	33
2	36	35	36
3	40	40	39

- Write a suitable Linear Model for this data. (9 Marks)
- Determine the effect of each sorghum variety. (4 Marks)
- State the statistical hypothesis for this data. (2 Marks)
- Compare the two new varieties against the local variety. (15 Marks)
- Can the Minister's wish be fulfilled? Please give reasons for your answer. (2 Marks)

Question TWO (2)

Studying the influence of education level and the gender of a farmer on the growing of cabbage could be two separate studies or the two factors could be combined into one study. A 4th year Agriculture Extension Student combined the two factors and obtained the following data (kg of cabbage) from the homogeneous experimental units.

<u>Education</u>	<u>Gender</u>	<u>Replication</u>		
Diploma	Male	27	23	24
	Female	24	24	22
Degree	Male	38	39	33
	Female	39	43	45

-
- a) Write an appropriate Linear Model. (11 Marks)
 - b) Estimate the simple effects of education. (2 Marks)
 - c) Estimate the simple effects of gender. (2 Marks)
 - d) Estimate the main effect of education. (1 Mark)
 - e) Estimate the main effect of gender. (1 mark)
 - f) Estimate interaction effect. (1 Mark)
 - g) Write the statistical hypothesis. (3 Marks)
 - h) Test the hypothesis. (19 Marks)
 - i) Make the conclusions. (2 Marks)

END OF EXAM



THE UNIVERSITY OF ZAMBIA

UNIVERSITY EXAMINATIONS: FINAL EXAM – JUNE 2022

AGG 4851

EXPERIMENTAL DESIGN AND STATISTICAL ANALYSIS

TIME: 3 Hours

Marks: 100

INSTRUCTIONS: ALL STATISTICAL TESTS SHOULD BE AT 5% SIGNIFICANT LEVEL
ANSWER ALL QUESTIONS AND WRITE LEGIBLY.

Question One (1)

A Researcher was interested in maize production. She wished to compare Open Pollinated (OP) and Hybrid varieties (H). She was also interested in liming for reducing the soil acidity in maize production. She wished to compare No Liming (NL) and Liming (L). Knowing that the Region of Zambia could influence the results, she undertook the experiment in the four regions (Region IA, Region IB, Region II and Region III). At the end of the research she obtained the following data:

Maize Yield by Treatment

Region	OP-NL	OP-L	H-NL	H-L
IA	26	46	39	58
IB	41	63	49	54
II	50	61	38	58
III	35	51	27	40

- Write the appropriate Linear Model for this data (12 Marks).
- Analyse the data and make recommendations (13 Marks).

Question Two (2)

A Researcher undertook a Vaccine Trial for Foot and Mouth Disease (FMD). He obtained vaccines from China (CV), Britain (BV) and France (FV). He knew that the results can be affected by the age of animals (Young, Mature and Old). He also knew that the Breed of an animal can also affect the results (Angoni, Barotse and Tonga). After taking these into consideration when carrying out the vaccine trial, he obtained the following data (percent mortality rate).

	ANGONI	TONGA	BAROTSE
YOUNG	CV = 5.6	FV = 6.2	BV = 6.5
MATURE	BV = 7.4	CV = 6.5	FV = 6.0
OLD	FV = 6.3	BV = 5.9	CV = 8.0

- a) Write an appropriate Linear Model for this data (11 Marks)
- b) Analyse the data and determine the vaccine with better mortality rate (14 Marks)

Question Three (3)

A Cattle Breeder randomly selected five (5) cows. Each cow produced milk for four (4) lactations as given below:

Cow	Milk Yield for Four Lactations			
1	26	41	50	35
2	39	49	38	27
3	46	63	61	51
4	58	54	58	40
5	70	75	71	74

- a) Write an appropriate Linear Model for this data (9 Marks)
- b) Analyse the data and estimate the variance components (16 Marks)

Question Four (4)

A Food Scientist was interested in determining the best type of Bread Flour. He was interested in three (3) types of bread flour (Pinto, Kings and Bunga). Bunga was the normally used flour while the other two types were new on the market. As far as he was concerned there were no factors that could influence

the results. The response variable was the time it took for the bread to bake. He collected the following data

<u>Flour</u>	<u>Time it took to Bake (Minutes)</u>				
Bunga	24	18	29	22	15
Pinto	32	30	36	27	26
Kings	46	39	37	50	45

- Write the appropriate Linear Model for this data (8 Marks)
- Analyze the data and determine which flour is best if any (17 Marks)

END OF EXAMINATION



THE UNIVERSITY OF ZAMBIA
UNIVERSITY EXAMINATIONS: FINAL EXAM – JUNE 2022

AGG 6811
BIOSTATISTICS

TIME: 3 Hours

Marks: 100

INSTRUCTIONS: ALL STATISTICAL TESTS SHOULD BE AT 5% SIGNIFICANT LEVEL
ANSWER ALL QUESTIONS AND WRITE LEGIBLY.
ANSWER THE TWO SECTIONS IN TWO SEPARATE ANSWER BOOKS

SECTION ONE (1)

ANSWER ALL THE QUESTIONS IN THIS SECTION

Question One (1)

A Cattle Breeder randomly selected five (5) cows. Each cow produced milk for four (4) lactations as given below:

<u>Cow</u>	<u>Milk Yield for Four Lactations</u>			
1	26	41	50	35
2	39	49	38	27
3	46	63	61	51
4	58	54	58	40
5	70	75	71	74

- a) Write an appropriate Linear Model for this data (4 Marks)
b) Analyse the data and estimate the variance components (16 Marks)

Question Two (2)

Distinguish between (5 Marks Each):

- a) Analysis of Variance and Analysis of Covariance
b) Simple regression analysis and Multiple regression analysis

- c) Model II and Model I
- d) Discriminant analysis and Factor analysis

Question Three (3)

A Researcher was interested in maize production. She wished to compare Open Pollinated (OP) and Hybrid varieties (H). She was also interested in liming for reducing the soil acidity in maize production. She wished to compare No Liming (NL) and Liming (L). Knowing that the Region of Zambia could influence the results, she undertook the experiment in the four regions (Region IA, Region IB, Region II and Region III). At the end of the research she obtained the following data:

Maize Yield by Treatment

Region	OP-NL	OP-L	H-NL	H-L
IA	26	46	39	58
IB	41	63	49	54
II	50	61	38	58
III	35	51	27	40

- a) Write the appropriate Linear Model for this data (6 Marks).
- b) Analyse the data and make recommendations (14 Marks).

SECTION TWO (2)

ANSWER QUESTION FOUR (4) AND EITHER QUESTION FIVE (5) OR QUESTION SIX (6)

Question Four (4)

- a) From the following data which was collected from RCBD experiment, give a comprehensive analysis of the data. The analysis should include mean separation (15 Marks).

Block	Bean Variety			
	A	B	C	D
1	1.92	1.95	2.92	2.49
2	1.90	2.03	2.18	2.10
3	2.14	1.39	2.45	1.63
4	2.21	1.52	2.04	1.34

- b) Show clearly, step by step, how randomization of 3 x 3 Balanced Incomplete Block Design can be achieved (5 Marks).

Question Five (5)

Write brief notes on the following (5 Marks each):

- a) Key Components of Research Proposal. Give the purpose for each one of them.
- b) Differences between *Balanced and Partially Balanced Incomplete Design*.
- c) Error Control.
- d) Use of Split-plot Design.

Question Six (6)

- a) List the Experimental Designs that you covered in class. Write a Statistical Linear Model for the two of these, defining all the terms in each of these two models (4 Marks). Under what circumstances would you use these two designs (4 Marks).
- b) In Agricultural Research one hears of **On Station Experiments** and On Farm Experiments. Outline the key differences between these types of experiments. What uncertainties are addressed by each of these types of experiments (12 Marks).

END OF EXAMINATION



THE UNIVERSITY OF ZAMBIA
SCHOOL OF AGRICULTURAL SCIENCES
BSC HUMAN NUTRITION

AGN 2110 FUNDAMENTALS OF HUMAN ANATOMY AND PHYSIOLOGY

DATE: 17TH FEBRUARY, 2022

TIME: 09:00 – 11:00

DURATION: TWO (2) HOURS

VENUE: OMNIA 1

1. THIS PAPER CARRIES 70 MARKS
2. ANSWER ALL QUESTIONS ALL QUESTIONS
3. ANSWER EACH QUESTION ON A SEPARATE PAGE IN THE BOOKLETS PROVIDED.
4. MARKS FOR EACH QUESTION ARE INDICATED IN PARENTHESES

Question 1:

Ms Chawama ate very salty popcorn in the afternoon of the 17th of February, 2022. After some considerable amount of time had elapsed, she was seen frequently drinking water. Briefly explain the physiological changes and implications on her body fluid compartments.

(10 marks)

Question 2:

Micronutrients are vital in almost all physiological processes of the human body, consequently micronutrient deficiencies increase the risk of morbidity and mortality. Identify one vitamin and briefly explain why it is important in wound healing.

(5 marks)

Question 3:

Using appropriate examples, briefly describe any five of the main activities of the gastrointestinal tract.

(10 marks)

Question 4:

- a) With the aid of a labelled diagram describe the formation of urine in the human body. **(10 marks)**
- b) Name the muscle structure found at inferior end of the bladder. **(1 marks)**
- c) Briefly describe the function of the muscle identified in (b) above. **(2 marks)**
- d) Using an example describe why women are more likely than men to develop urinary tract infections (UTIs). **(2 marks)**

Question 5:

- a) In heart anatomy, what are the major components of the fibrous skeleton (1 mark)
- b) Assuming you are invited to the heart as a visitor, which “gate”-valve, in the language of the heart, would you use to find yourself in the left ventricle? (1 mark)
- c) Identify the consequences that would follow if the valve identified in (b) does not fully close at each heart beat (2 marks)
- d) Briefly describe the role of *autorhythmicity* in cardiac muscles (2 marks)
- e) List the two circuits of the heart and describe their pathways (4 marks)

Question 6:

- a) Describe the functions of the human nervous system? (5 marks)
- b) Identify the two subdivisions of the motor nervous systems and their function (5 marks)

Question 7

Identify the three main types of blood cells and their functions (6 marks)

Define **Haematopoiesis** and list the organs where it takes place (4 marks)

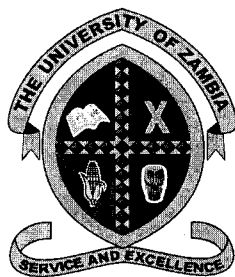

**THE UNIVERSITY OF ZAMBIA
SCHOOL OF AGRICULTURAL SCIENCES
DEPARTMENT OF FOOD SCIENCE AND NUTRITION**

**2020/2021 ACADEMIC YEAR SUPPLEMENTARY
EXAMINATION**

**COURSE: AGN 2212
Principles of Human Nutrition**

Date: Monday, 14th February 2022

Time: 09:00 – 11:00hrs

Duration: Two (2) Hours

Venue: Omnia LT1

INSTRUCTIONS TO CANDIDATES:

- 1. This paper consists of Section A and Section B**
 - 2. Please read the guidance for each section carefully; answer ALL questions**
 - 3. Each question is allocated marks as shown in parenthesis**
-

SECTION A

(10 Marks)

Answer **ALL** questions in this section

1. Which of the following situations is most likely associated with iron deficiency anaemia? (1 mark)
 - a. Mutale has an enlarged thyroid gland and is constantly feeling tired.
 - b. Mwaka notices high blood pressure for the past 5 days.
 - c. Grace has been feeling tired, weak and has pica.
 - d. George's finger and toe nails are whitening with time
2. Which of the following minerals are associated with antioxidant defences? (1 mark)
 - a. Molybdenum and Potassium
 - b. Iron and Selenium
 - c. Fluoride and Calcium
 - d. Magnesium and Phosphorus
3. Engulfment of some nutrients/particles by the cell membrane of enterocytes is known as
4. Give an example of a situation when dispensable amino acids become indispensable.
.....
5. Give one (1) example of a sugar acid.

SECTION B

Answer **ALL** questions in this section

Question 1

- a) List and describe two factors that influence the absorption of minerals. **(6 marks)**
- b) Some organic substances in food are known to have inhibiting or enhancing influence on dietary minerals. Complete the table below; **(10 marks)**

Dietary component	Three (3) Food sources	Brief description of influence on mineral of choice
1. Protein		
2. Polyphenols		

- c) What is nonheme iron? Briefly describe one way in which you can improve the absorption of nonheme iron. **(4 marks)**
- d) Describe how iron is recycled or turned over in the human body. **(10 Marks)**

Question 2

a) Gastric juice plays a vital role in the functioning of the stomach.

i) Describe the composition of gastric juice? **(3 Marks)**

ii) List **four (4)** functions of hydrochloric acid (HCl) in the stomach.

(8 Marks)

b) Vitamin B12 is considered the last vitamin to be discovered.

i) List **three (3)** dietary sources of Vitamin B12 **(3 Marks)**

ii) Describe the digestion, absorption, transport and storage of vitamin B12 in the human body. **(10 Marks)**

c) Define pernicious anaemia. Give two (2) examples of risk factors of pernicious anemia. **(6 Marks)**

Question 3

a) Describe each of the following components. For each one of the factors listed below, briefly describe how long term intake of each component affects an individual's nutritional wellbeing. **(10 marks)**

i) High fructose corn syrup

ii) Diacylglycerol

iii) Incomplete proteins

b) Mrs Phiri has high blood pressure and has also been taking diuretics for some months. Describe in detail how this condition is associated with serum levels of the following minerals.

(10 marks)

i. Calcium

ii. Potassium

iii. Magnesium

END OF EXAMINATION

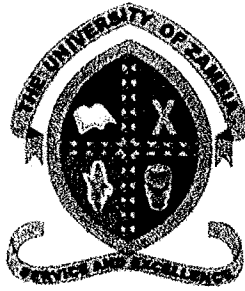

THE UNIVERSITY OF ZAMBIA
SCHOOL OF AGRICULTURAL SCIENCES
DEPARTMENT OF FOOD SCIENCE & NUTRITION

BSc HUMAN NUTRITION

PRINCIPLES OF DIETETICS
AGN 3232
2021 SUPPLEMENTARY EXAMINATIONS

DATE: THURSDAY 17TH FEBRUARY, 2022

TIME: 14.00-15.30H

DURATION: ONE AND HALF HOURS

VENUE: OMNIA 1

INSTRUCTIONS TO THE CANDIDATES:

1. THIS PAPER CARRIES 75 MARKS
2. ANSWER **ALL** QUESTIONS

Question 1

- a) An individual who constantly consumes foods high in trans-fatty acids and saturated fats is found with very high levels of low density lipoproteins (LDL) after laboratory tests.
- i. What disease is this person at risk of? (1 mark)
 - ii. What type of diet would you recommend? Describe this diet in detail. (8 marks)
 - iii. What other lifestyle interventions would you recommend? (3 marks)
- b) A patient with irregular stool and constipation needs nutritional advice from you as a dietitian.
- i. What type of diet would you recommend? (1 mark)
 - ii. Which type of fiber would be most beneficial to this individual? Give reasons for your answer with two examples of foods high in this particular fiber. (3 marks)
 - iii. Describe in detail the benefits of the diet you have recommended in i. above. (9 marks)

Question 2

The elderly are prone to several conditions due to aging and these include autoimmune atrophic gastritis and tooth decay.

- a. Describe in detail how and why B12 deficiency occurs in autoimmune atrophic gastritis. Be sure to explain what happens to the food when ingested, all the way to the small intestines. (8 marks)
- b. You prescribe a mechanical soft diet to an elderly woman who has difficulties chewing due to tooth decay
 - i. Describe in detail the mechanical soft diet and give two (2) examples of food that may be included in this diet (6 marks)
 - ii. Give three (3) signs that you need to look out for when the elderly patient is on this diet? (3 marks)
 - iii. What nutrient deficiencies are this elderly person likely to have as a result of tooth decay and why? (3 marks)

Question 3

- a. Describe in detail alcohol absorption and metabolism, beginning from the mouth all the way up to the small intestines. (15 marks)
- b. Explain why vegetarians are at lower risk of developing cancer and heart disease (10 marks)

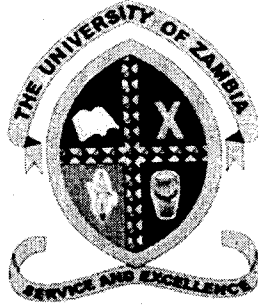

THE UNIVERSITY OF ZAMBIA
SCHOOL OF AGRICULTURAL SCIENCES
DEPARTMENT OF FOOD SCIENCE & NUTRITION

BSc HUMAN NUTRITION

PRINCIPLES OF DIETETICS
AGN 3232
2022 END OF YEAR EXAMINATIONS

DATE: FRIDAY 25TH NOVEMBER, 2022

TIME: 09:00-12:00H

DURATION: THREE (3) HOURS

VENUE: OMNIA 1

INSTRUCTIONS TO THE CANDIDATES:

1. THIS PAPER CARRIES 100 MARKS AND HAS TWO (2) SECTIONS; SECTION A AND B
2. ANSWER **ALL** QUESTIONS

SECTION A (25 Marks)

1. T or F. Women should consume less alcohol than men because they produce less aldehyde dehydrogenase (1 mark)
2. List two (2) important steps that must be followed during a nutrition Intervention in the Nutrition Care Process (2 marks)
3. Provide three (3) possible ways in which the body processes lactate (3 marks)
4. T or F. A score of 1 on the MUST tool means that one is hospitalized (1 mark)
5. List three (3) ways in which the concentration of isotopes in the body can be measured when using the Dilution method (3 marks)
6. Write short notes on plaque buildup in cardiovascular disease (5 marks)
7. T or F. Improperly stored fish naturally contain histamines which can cause food intolerances (1 mark)
8. Give three (3) characteristics of a full liquid diet (3 marks)
9. Why do vegetarians/ vegans have a lower risk for cancer? (5 marks)
10. T or F. Mashbooh foods are prohibited in the Muslim religion (1 mark)

SECTION B (25 Marks Each)

Question 1

a) Cora is a 26 year old woman with a BMI of 26 kg/m². Every morning, Cora eats two (2) cups of muesli with the following nutrition facts label:

Nutrition Facts	
4 servings per container	
Serving size 1 1/2 cup (208g)	
Amount per serving	
Calories	240
% Daily Value*	
Total Fat 4g	5%
Saturated Fat 1.5g	8%
Trans Fat 0g	
Cholesterol 5mg	2%
Sodium 430mg	19%
Total Carbohydrate 46g	17%
Dietary Fiber 7g	25%
Total Sugars 4g	
Includes 2g Added Sugars	4%
Protein 11g	
Vitamin D 2mcg	10%
Calcium 260mg	20%
Iron 6mg	35%
Potassium 240mg	6%

* The % Daily Value (DV) tells you how much a nutrient in a serving of food contributes to a daily diet. 2,000 calories a day is used for general nutrition advice.

Colour on traffic light label	Red	Yellow	Green
Sugar	> 15g	5 - 15g	< 5g
Fat	> 20g	5 - 20g	< 5g
Saturated fat	> 5g	1.5 - 5g	< 1.5g
Sodium	> 0.6g	0.1 - 0.6g	< 0.1g
Salt	> 1.5g	0.3g - 1.5g	< 0.3g

INGREDIENTS: Whole Grain Oats, Mango (Mango, Cane Sugar, Citric Acid), Coconut Flakes, Sorghum, Pumpkin Seeds, Sliced Almonds, Sunflower Seeds, Macadamia Nuts, Freeze-Dried Strawberry Pieces, Quinoa Flour Crisps.

Bob's Red Mill Natural Foods, Inc.
13521 SE Pheasant Court
Milwaukie, Oregon 97222 U.S.A.

Manufactured in a facility that uses tree nuts and soy.
Tested and confirmed Gluten Free in our quality control laboratory.
Store in a cool, dry place. Keeps best refrigerated after opening.



- i. What is the total number of Calories Cora obtains from all the macronutrients each day? (6 marks)
- ii. Using the traffic light system, categorize the sugars, fats, saturated fat and sodium using the different colors and give a reason for each answer (4 marks)
- iii. Why should you be cautious about using the traffic light system? (2 marks)
- iv. Which ingredient was added in the largest quantity and which one is the least in quantity? Give reasons for your answer (4 marks)
- v. Cora decides to lose weight by completely eliminating the muesli from her diet. If all other input and output remains the same, how much weight will Cora lose in three (3) months (12 weeks) (9 marks)

Question 2

- a. Alcohol consumption beyond the recommended amounts may cause several adverse effects on the body.
- Discuss in detail the effect of alcohol abuse on both water-soluble and fat-soluble vitamins (12 marks)
 - Why should mothers avoid alcohol **during breastfeeding**? (5 marks)
- b. Explain why non-vegetarians are at higher risk of osteoporosis due to consumption of meat? (8 marks)

Question 3

- a. Clifford Chabala is a 20-year-old soccer player who weighs 63 kg. He is currently in camp, preparing for the Premier League Finals which will begin next week. He has been advised by some of his friends that he should take an ergogenic aid in order for him to perform better.
- Define the term ergogenic aid. (1 mark)
 - Name four (4) supplements that have been shown to be safe and effective at recommended doses and explain how they work to improve performance. (8 marks)
 - If Clifford is a vegan, how many grams of protein should he consume daily? (5 marks)
- b. A patient with irregular stool and constipation needs nutritional advice from you as a dietitian.
- What type of diet would you recommend? (1 mark)
 - Which type of fiber would be most beneficial to this individual? Give reasons for your answer with two examples of foods high in this particular fiber. (3 marks)
 - Describe in detail the benefits of the diet you have recommended in (i). above. (7 marks)

Annex

General Protein Recommendations based on Exercise Intensity and Duration

Type of exercise	g/kg body weight/ day	Absolute (g) e.g 70 kg athlete
Sedentary	0.8 - 1.0	56
Regular exercise	1.0	70
Endurance (general training)	1.2 - 1.6	84 - 112
General (heavy training)	2.0	140
Strength	1.2 - 1.7	84 - 119
Adolescent or strength athlete in the early stages of training	1.5 - 2.0	105 - 140

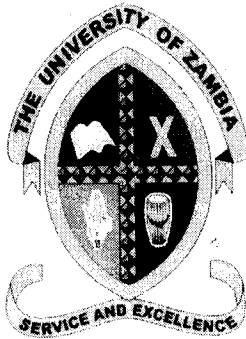

THE UNIVERSITY OF ZAMBIA
SCHOOL OF AGRICULTURAL SCIENCES
DEPARTMENT OF FOOD SCIENCE & NUTRITION

BSc HUMAN NUTRITION

AGN 3510
NUTRITION COMMUNICATION AND HEALTH PROMOTION
2020/2021 END OF YEAR SUPPLEMENTARY EXAMINATIONS

Date: 14th February, 2022

Time: ~~09:00 - 10:30~~ hours
14:00 - 15:30 hours

Duration: 1hr 30 minutes

Venue: OMNIA 1 LT

INSTRUCTIONS TO CANDIDATES:

INSTRUCTIONS TO THE CANDIDATES:

1. THIS PAPER HAS TWO (2) QUESTIONS AND EACH QUESTION CARRIES 15 MARKS
2. ANSWER ALL THE QUESTIONS

QUESTION ONE (15 MARKS)

1. Which of the following is an example of a physical influence on food choice?
a. sadness b. region c. Judaism c. cost
2. If a person chooses to eat a food because it reminds them of a pleasant experience, that is an example of what kind of influence on food choice?
a. Emotional b. Intellectual c. Physical d. Economic
3. Which of the following is one of the primary diseases that can affect food choices?
a. Diabetes b. Appendicitis c. Measles d. Pneumonia
4. A reaction to a food caused by an inability to digest or process a food is a:
a. food allergy b. food intolerance c. food poisoning d. food preference
5. A reaction to a food that involves an immune response is a
a. food allergy b. food intolerance c. food poisoning d. food preference
6. Which of the following is an example of an economic factor affecting food choice?
a. Total price b. ease of preparation c. local production d. unpleasant memory association
7. Appetite, emotions, thoughts, stress and personal likes and dislikes are all examples of:
a. Economic influence b. psychological influence c. cultural influence d. intellectual influence
8. Ethnicity, religious, social groups, customs, and tradition are all examples of:
a. physiological influence b. psychological influence c. Cultural influence d. Situational/social influence
9. Media advertising influence on food choices is
a. Internal b. External
10. Economic influence on food choice is
a. Internal b. External
11. Environmental influences on food choice are
a. Internal b. External
12. Ecological factors, climate, land available, geografia, and local agriculture are:
a. Media b. Economic c. Environmental d. Technological
13. Food processing/additives, food preparation, biotechnology are what types of food influences?
a. Media b. Economic c. environmental d. technological
14. Eating convenience foods because a person doesn't know how to cook is an example of which factor affecting food choices?
a. economic influences b. Intellectual factors c. psychological influences d. emotional influences
15. Choosing to eat pizza at home with friends and family when a parent just became unemployed helps meet which type of need? _____

QUESTION TWO (15 MARKS)

- i. The following are steps in advocacy planning. Rearrange them in the order in which they occur starting with the first step: **(7 marks)**
- A. Making the case
 - B. fostering dialogue through multi-actor collaboration
 - C. Understanding and mapping the context
 - D. Defining what needs to change and how to change it
 - E. Reviewing our plan and knowing if we have made a difference
 - F. Conveying our messages
 - G. Knowing who can make the change happen
- ii. State two (2) **ADVANTAGEs** and two (2) **DISADVANTAGEs** of being part of nutrition advocacy alliance **(4 Marks)**
- iii. List two (2) health behaviour theories in health promotion **(2 marks)**
- iv. State one stage of the communication cycle and briefly explain what happens during that stage **(2 marks)**

END OF EXAMINATION



**THE UNIVERSITY OF ZAMBIA
SCHOOL OF AGRICULTURAL SCIENCES
DEPARTMENT OF FOOD SCIENCE & NUTRITION**

BSC HUMAN NUTRITION PROGRAMME

AGN 4122 NUTRIENT AND DRUG INTERACTIONS

2021-2022

DATE: 7 NOVEMBER 2022

TIME: 14:00-17:00

DURATION: THREE (3) HOURS

VENUE: FSN1

Instructions

1. The paper consists of **THREE (2)** sections. Therefore, you should **ATTEMPT ALL SECTIONS**.
2. Section A should be answered in this question paper, while Section B should be answered in a separate booklet.
3. It is **ESSENTIAL** that you indicate your Student Number, the section, and the number of each question you have attempted on the cover of every booklet. Also, you should indicate your Student Number at the top of every answer sheet page.
4. Complete answer booklets should be handed in and all tied together. These will be collected **BEFORE** you leave your seat.

SECTION A: MULTIPLE CHOICE (30 MARKS)

INSTRUCTION:

CIRCLE THE CORRECT ANSWER FROM THE OPTION PROVIDE

1. The following factors should be considered when assessing the possibility of food-drug interactions in a patient. Except
 - a) Administered Medicines
 - b) Illness of the patient
 - c) Life Style of the patient
 - d) Name of the patient

2. Pharmacokinetics is:
 - a) The study of biological and therapeutic effects of drugs
 - b) The study of absorption, distribution, metabolism and excretion of drugs
 - c) The study of mechanisms of drug action
 - d) The study of methods of new drug development

3. The main mechanism of most drugs absorption in GI tract is:
 - a) Active transport (carrier-mediated diffusion)
 - b) Filtration (aqueous diffusion)
 - c) Endocytosis and exocytosis
 - d) Passive diffusion (lipid diffusion)

4. Which of the following are the risk factors for Drug – Nutrient interactions: Except
 - a) Impaired Renal system
 - b) Impaired Hepatic System
 - c) Rehydration
 - d) Prolong Drug Use

5. Drugs with ENHANCED bioavailability in the presence of Food, except.
 - a) Nitrofurantoin
 - b) Griseofulvin
 - c) Penicillins
 - d) Carbamazepine

6. Drugs with REDUCED bioavailability in the presence of Food, except.
 - a) Tetracyclines
 - b) Warfarin
 - c) Theophylline
 - d) Chloroquine

7. Some Drugs and Nutrients are absorbed via Active Transport, what is implied by ‘active transport’?
 - a) Transport of drugs through a membrane by means of diffusion
 - b) Transport without energy consumption
 - c) Engulf of drug by a cell membrane with a new vesicle formation
 - d) Transport against concentration gradient

8. What does the term "bioavailability" mean?
- Plasma protein binding degree of substance
 - Permeability through the brain-blood barrier
 - Fraction of an uncharged drug reaching the systemic circulation following any route administration
 - Amount of a substance in urine relative to the initial dose
9. All of the following are clinical symptoms of Invasive bacterial gastroenteritis Except:
- Diarrhea Profuse and watery
 - Diarrhea Mucoïd and bloody
 - Abdominal pain
 - Fever
10. Pick out the appropriate alimentary route of administration when passage of drugs through liver is minimized:
- Oral Transdermal
 - Rectal
 - Intraduodenal
 - Which route of drug administration
11. The following microorganism are commonly known bacteria, except:
- Staphylococcus aureus
 - Clostridium botulinum
 - Salmonella
 - Clostridium perfringens
12. Mega doses of which vitamin are sometime beneficial viral respiratory infections
- Vitamin C
 - Vitamin A
 - Vitamin K
 - Vitamin B
13. The following drug factors can modify nutritional status of person, except
- Dose of a drug
 - Duration of Treatment
 - Drug combination used in therapy
 - Source of the drug
14. Which of the following interfere with the metabolism of vitamin B6?
- Isoniazide
 - Ethanol
 - Carbamazepine
 - All of the above
15. If you are taking digoxin for the treatment of heart failure, you must avoid this glycyrrhiza-containing food.
- Orange Juice
 - Lunch Meats
 - Natural Black Licorice
 - Hot Dogs

16. Half life ($t_{1/2}$) is the time required to:
- Change the amount of a drug in plasma by half during elimination
 - Metabolize a half of an introduced drug into the active metabolite
 - Absorb a half of an introduced drug
 - Bind a half of an introduced drug to plasma proteins
17. People being treated for depression with MAOIs should avoid aged cheese and chocolate because they contain this amino acid.
- Tyramine
 - Threonine
 - Glutamine
 - Cysteine
18. The following drugs are recommended to be taken with food to maximize absorption except
- Albendazole
 - Amiodarone
 - Griseofulvin
 - Ciprofloxacin
19. The following drugs should NOT be taken with food to allow optimal absorption except
- Ampicillin
 - Isoniazid
 - Norfloxacin
 - Hydralazine
20. Which class of drugs cause hypokalemia as result of loss of K (Potassium)
- Loop Diuretics
 - Spirolactone
 - Acetaminophen
 - Acetazolamide
21. Which of the following factors can influence the bioavailability of Drugs/Nutrients?
- Altering the luminal PH
 - Gastric emptying rate
 - Chemical Interaction
 - All of the above
22. The most appropriate laboratory test to monitor a patient with diabetes mellitus?
- Hgb A1c
 - D-dimer
 - Alkaline phosphate
 - C-reactive protein Tyramine

23. In Peptic Ulcer disease, the following are true.
- Encourage the intake of coffee
 - Eat an hour before bed time
 - Pain killer such NSAIDs are the drug of choice for pain relief
 - None of the above
24. Which of the following Anti-Tuberculosis drugs interferes with the metabolism of Vitamin B6?
- Rifampicin
 - Isoniazid
 - Pyrazinamide
 - Streptomycin
25. Immediate allergy reaction (type I allergic reaction) is:
- An allergic or immune response that begins within a period lasting from a few minutes to about an hour after exposure to an antigen to which the individual has been sensitized
 - An allergic reaction that becomes apparent only hours after contact
 - An allergic reaction that results from the formation of antigen-antibody complexes between a foreign antigen and IgM or IgG immunoglobulins. (It occurs during blood transfusion reactions and in hemolytic disease of the newborn)
 - An allergic reaction that is due to the presence of elevated levels of antigen-antibody complexes that cause tissue damage
26. Pernicious anemia is:
- A severe form of anemia most often affecting elderly adults, caused by a failure of the stomach to absorb vitamin B12 and characterized by abnormally large red blood cells, gastrointestinal disturbances, and lesions of the spinal cord
 - A form of anemia in which the capacity of the bone marrow to generate red blood cells is defective, caused by a bone marrow disease or exposure to toxic agents, such as radiation, chemicals, or drugs
 - Anemia characterized by a decrease in the concentration of corpuscular hemoglobin
 - All of the above
27. One of the most common food-drug interaction regarding Warfarin occurs with Green leafy Vegetables such as Broccoli, Lettuce due to their rich Vitamin K content. This is because
- Vitamin K leads to an increase in clotting factors
 - Vitamin K leads to a decrease in clotting factors
 - Vitamin K decreases the metabolism of warfarin
 - Vitamin K increases the metabolism of Warfarin
28. Which of the following vitamins is given along with isoniazide in treatment of tuberculosis?
- Nicotinic acid
 - Riboflavin
 - Pyridoxine
 - Ascorbic acid

29. Which class of drugs can result in a hypertensive crisis also known cheese/tyramine reaction when co-ingested with tyramine rich food
- Monoamine Oxidase Inhibitors (MAOIs)
 - Analgesics
 - Antibiotics
 - Antihypertensives
30. Pharmacodynamics involves the study of following EXCEPT:
- Biological and therapeutic effects of drugs
 - Absorption and distribution of drugs
 - Mechanisms of drug action
 - Drug interactions
31. According to Paracelsus (1493-1541), Food or drugs can be poisonous, however it mainly depends on;
- Dose
 - Quality
 - Population
 - Environment
32. The following is correct about Bismuth subsalicylate EXCEPT
- Inhibits activity of pepsin
 - Increases secretion of mucus
 - Inhibits formation of prostaglandins
 - Interacts with glycoproteins in necrotic mucosal tissue
33. Which of the following statements concerning vitamin B12 (cyanocobalamin) functions are true:
- Active functional form is pyridoxal phosphate, which is an essential coenzyme for transamination and decarboxylation of amino acids in more than 50 different enzyme systems
 - Essential constituent of coenzyme A, the important coenzyme for acyl transfer in the TCA cycle and de novo fatty acid synthesis
 - Coenzyme for numerous metabolic reaction, including transformation of methylmalonyl CoA to succinyl CoA in the metabolism of propionate; DNA synthesis (acts in concert with folic acid); transmethylation e.g. methionine synthesis from homocysteine
 - An extremely important antioxidant, which protects cell membrane lipids from peroxidation by breaking the chain reaction of free radical formation to which polyunsaturated fatty acids are particularly vulnerable
34. Long periods of parenteral nutrition may not recommended because of _____
- It increases the toxicity of blood
 - It puts pressure on the kidney
 - It puts pressure on the heart
 - It causes the GI track to degenerate

35. What is the definition of a dietary supplement?
- a) Those that contain ergogenic substance
 - b) Those that are not regulated by law
 - c) Those that contain at least 1 of these: vitamin, mineral, herb, botanical, amino acid, metabolite, extract of a plant
 - d) Those that contain ingredients that have been scientifically proven to have the effect that the manufacturer states on the label
36. Tick the main approach of peptic ulcer treatment:
- a) Neutralization of gastric acid
 - b) Eradication of *Helicobacter pylori*
 - c) Inhibition of gastric acid secretion
 - d) All the above
37. Gastric acid secretion is under the control of the following agents EXCEPT:
- a) Histamine
 - b) Acetylcholine
 - c) Serotonin
 - d) Gastrin
38. Indicate the drug belonging to proton pump inhibitors:
- a) Pirenzepine
 - b) Ranitidine
 - c) Omeprazole
 - d) Trimethaphan
39. All of the following agents intensify the secretion of gastric glands EXCEPT:
- a) Pepsin
 - b) Gastrin
 - c) Histamine
 - d) Carbonate mineral waters
40. Select the drug stimulating the protective function of the mucous barrier and the stability of the mucous membrane against damaging factors:
- a) Metronidazole
 - b) Sucralfate
 - c) Misoprostol
 - d) Omeprazole
41. Choose the drug that causes constipation:
- a) Sodium bicarbonate
 - b) Aluminium hydroxide
 - c) Calcium carbonate
 - d) Magnesium oxide

42. All of the following drugs stimulate appetite EXCEPT:
- Vitamins
 - Cyproheptadine
 - Amiloridine
 - Insulin
43. Which of the following statements concerning vitamin B1 functions are true:
- An extremely important antioxidant, which protects cell membrane lipids from peroxidation by breaking the chain reaction of free radical formation to which polyunsaturated fatty acids are particularly vulnerable
 - An essential coenzyme for oxidative decarboxylation of alpha-keto acids, most important being conversion of pyruvate to acetyl coenzyme A
 - Specifically required for synthesis of prothrombin and several other clotting factors
 - Essential constituent of the flavoproteins, flavin mononucleotide (FMN) and flavin adenine dinucleotide (FAD)
44. Anaphylactic shock is a severe, sometimes fatal allergic reaction characterized by, Except;
- Low blood Pressure
 - High blood Pressure
 - urticaria,
 - breathing difficulties
45. Tick the drug forming a physical barrier to HCL and Pepsin:
- Ranitidine
 - Sucralfate
 - Omeprazole
 - Pirenzepine
46. Delayed allergy reaction (type IV allergic reaction) is:
- An allergic or immune response that begins within a period lasting from a few minutes to about an hour after exposure to an antigen to which the individual has been sensitized
 - An allergic reaction that becomes apparent only hours after contact
 - An allergic reaction that results from the formation of antigen-antibody complexes between a foreign antigen and IgM or IgG immunoglobulins. (It occurs during blood transfusion reactions and in hemolytic disease of the newborn)
 - An allergic reaction that is due to the presence of elevated levels of antigen-antibody complexes that cause tissue damage
47. Side effect of first-generation histamine H₁ antagonists is:
- Aplastic anemia
 - Vomiting, tinnitus, decreased hearing
 - Sedation
 - Gastric ulcers and upper gastrointestinal bleed

48. Which of the following statements concerning the anti-inflammatory effect of NSAIDs are TRUE?
- a) Anti-inflammatory effect of NSAIDs results from inhibition of cyclooxygenase
 - b) Anti-inflammatory effect of NSAIDs results from inhibition of phospholipase A2 and reducing prostaglandin and leukotriene synthesis
 - c) Anti-inflammatory effect of NSAIDs results from induction of cyclooxygenase II expression which results in reducing the amount of an enzyme available to produce prostoglandins
 - d) All of the above
49. The following are mechanisms of cell-mediated food allergies Except:
- a) interaction between specific food allergens and sensitized T lymphocytes
 - b) interaction between specific food allergens and sensitized B lymphocytes
 - c) Lymphocyte stimulation initiates the release of cytokines and lymphokines which produces a localized inflammatory response.
 - d) Antibodies are not involved in these reactions
50. At absorption, some drugs interact chemically by forming insoluble complex with divalent/trivalent cations. Example of such drugs are:
- a) Ciprofloxacin Oral Tablets
 - b) Paracetamol Oral Tablets
 - c) Metronidazole Oral Tablets
 - d) Griseofulvin Oral Tablet

SECTION B

ANSWER ALL QUESTIONS IN THIS SECTION (30MARKS)

1. List four factors that can influence food-Drug interactions. (4 marks)

.....
.....
.....
.....
.....
.....
.....
.....

2. Define Food-Drug Interaction. (2 marks)

.....
.....
.....

3. List four benefits of minimising food-drug intractions. (4 marks)

.....
.....
.....
.....
.....
.....
.....

4. Mention Two adverse effects of food-drug interactions. (2 marks)

.....
.....
.....
.....
.....
.....

5. List four ways of classifying drugs. (4 Marks)

.....
.....
.....
.....
.....
.....
.....

6. Define a drug or medicine. (2 marks)

.....
.....
.....

7. List 2 common food-drug interactions with examples of each. (4 marks)

.....
.....
.....
.....
.....

8. Mention four nutrition therapy strategies (Non- Drug therapy) in managing diabetes. (4 Marks)

.....
.....
.....
.....
.....
.....

9. Mention two major global nutrition problems. (2 Marks)

.....
.....

.....
.....
10. Mention atleast two United Nation Sustainable Development Goals (SDGs) that are aimed at improving Nutrition globally (2 Marks)
.....
.....
.....
.....

SECTION C

ANSWER ONLY ONE QUESTION FROM THIS SECTION

EACH QUESTION CARRYS 20 MARKS

QUESTION 1

- a) Compare and contrast Pharmacokinetics and Nutrient kinetics (4 Marks)
- b) Compare between immediate and delay hypersensitivity of food allergy (4 marks)
- c) Explain with examples how food can influence the bioavailability of drugs by
 - i. Formation of complexes (4 marks)
 - ii. Alteration of the luminal PH (4 marks)
- d) Mention four Nutrition therapy strategies for constipation (4 Marks)

QUESTION 2

- a) Compare and Contract Foodbourne Infections and Foodbourne Intoxication (4 marks)
- b) Comparison between toxigenic and invasive bacterial gastroenteritis (4 Marks)
- c) List Four Contra-indication for Enteral Feeding (4 Marks)
- d) Demonstrate how an illness can affect the nutrition status of a patient (4 marks)
- e) List four benefits of minimising food-drug interactions. (4 marks)

END OF TEST

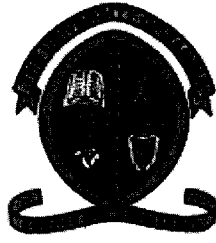

THE UNIVERSITY OF ZAMBIA
SCHOOL OF AGRICULTURAL SCIENCES
DEPARTMENT OF FOOD SCIENCE & NUTRITION

BACHELOR OF HUMAN NUTRITION

DIET FORMULATION & DIETETIC MANAGEMENT

AGN 4410

2020/21 END OF YEAR EXAMINATIONS

DURATION: THREE HOURS

VENUE: OMNIA 1

DATE: TUESDAY, 15th NOVEMBER 2022

TIME: 14:00 TO 17:00 HOURS

NUMBER OF STUDENTS: 14

INSTRUCTIONS TO THE CANDIDATES:

1. PLEASE READ THE INSTRUCTIONS CAREFULLY.
2. THIS PAPER HAS SIX QUESTIONS.
3. EACH QUESTION CARRIES 20 MARKS.
4. ANSWER ALL QUESTIONS.

Question One**[20 marks]**

- (1) Critical thinking skills are important for Nutrition and Dietetic students. Some of the components of critical thinking include specific knowledge base and experience. How do you interpret those two elements of critical thinking in relation to the profession?
- (2) Differentiate between values and ethics.
- (3) Explain the following characteristics of the dietetics profession.
 - (a) Body of knowledge.
 - (b) Education.
 - (c) Autonomy.
 - (d) Service.
- (4) There are several disciplines of the dietetics profession one can specialize in. Identify one area you can specialize in and justify your choice based on your passion and strength.
- (5) With regards to the Zambia Food Based Dietary Guidelines, answer the following questions
 - (a) What is the basis for grouping foods in six food groups and briefly discuss them?

Question Two**[20 marks]**

Severe acute malnutrition (SAM) is one of the most common causes of illness and death among children under 5 years of age worldwide. Many children under 5 with SAM die at home without care or present to the hospital late and with severe medical complications. The lives of many children with SAM can be saved by implementing active case-finding in the community and systematic case-finding in health facilities to identify children with SAM and refer them for early treatment. Chimwemwe is a 4 year old boy who has been admitted to a malnutrition ward at Kitwe Teaching Hospital due to SAM. He has been medically treated and is now on feeds prescribed by a Nutritionist. Answer the following questions;

- (i) Define the following terms;
 - (a) Severe Acute Malnutrition
 - (b) Global Acute Malnutrition
 - (c) Reductive adaptation
- (ii) Explain the difference between F-75 and F-100.
- (iii) How can you identify a child with SAM?
- (iv) When should naso-gastric feeding be initiated among SAM patients?
- (v) Would you use ORS to treat diarrhoea in children with SAM? Explain your reasoning.
- (vi) List some of the signs of shock.

- (vii) What type of antibiotics are administered to children with SAM?

Question Three

[20 marks]

George a.k.a Umuvilivili is a 42 year old man with severe chronic obstructive liver failure. He has been referred to the Medical Clinic for a nutrition assessment in view of Liver transplantation. George receives sickness benefits via NHIMA, lives alone and is often anxious and depressed. His health affects his day to day functions and he is very limited in what he is able to do. He attends outpatient care at the hospital twice a week for rehabilitation. He has never seen a dietitian before.

Weight history: Height: 183cm BMI 18 kg/m²

Current Weight: 61kg Usual weight: 77kg

Weight loss has occurred gradually over the last 6 years. George has had 5 hospital admissions this year. To receive a liver transplant, George must reach a goal weight of 67 kg.

Diet history: Breakfast: 1x Maize meal Porridge , milk, sugar

Lunch: Soup, occasionally yogurt

Dinner: Small meal of meat, potato and vegetables, (sometimes too tired to eat)

Snacks: Rarely

- (i) Provide a summary nutrition assessment for George, noting any assumptions made.
- (ii) George's condition worsens post transplantation. His GCS is now 9/15. You recommend administration of enteral nutrition. Briefly describe preliminary actions you will take before feeding George via EN.
- (iii) Describe the nutrition content of George's recommended feed.
- (iv) Calculate the nutritional requirement for George in 24 hrs.
- (v) Calculate the flow rate of the feed according to your chosen feeding regime.
- (vi) Determine the total volume of feed to be administered in 24 hrs.
- (vii) What ingredients in the feed do you recommend for George to reduce inflammation?

Question Four

[20 marks]

Ndopu is admitted in the ICU for past 7 days. Much of the nutrition provided so far been through common fluids such as ringers lactate, dextrose and normal saline. Unfortunately his medical diagnosis cannot allow him to feed enterally.

- (i) A 3 in 1 bag is highly recommended for use in critical care of patients in developing countries. Give four reasons why such a feed is suitable for Zambian hospitals.
- (ii) Describe what will be your preliminary steps in providing parenteral nutrition for Ndopu.
- (iii) What consumables and equipment is associated with parenteral nutrition?
- (iv) Why is osmolality of a feed a major concern before administration of parenteral feeds?
- (v) Mention four contraindications for parenteral feeding?
- (vi) In patients with low urine output, what may you clinically consider for them before you administer parenteral feeds?
- (vii) What nutrients are commonly missing in 3 in 1 feeds. Mention one probable solution for this gap?

Question Five

[20 marks]

Sara is a 38-year-old female with type 2 diabetes (T2D). She recently noticed blood in her urine and has had a sore on her foot that does not seem to be improving. She goes to the hospital where you are working and is diagnosed with a severe urinary tract infection (UTI). Her blood fasting sugar levels are 17 mmol/l. She is thus admitted to the ward. After your assessment, you find out that Sara takes a can of coke every day and seems to enjoy consuming food from Hungry Lion every other day.

Wt: 84kg, Ht: 1.68m, Disease factor: 3.5%

- (i) Explain why T2D might be causing the UTI and the sore that is not healing on its own
- (ii) Develop a nutritional diagnosis for Sara
- (iii) List the three (3) nutrition diagnosis components and identify these in your diagnosis in b) above
- (iv) Provide three (3) goals of diabetic dietary management

(v) The Doctor prescribes rapid acting insulin for Sara

- (a) What does this mean with respect to the diabetes management algorithm?
- (b) How long does it take for this type of insulin to peak?
- (c) What type of food are you going to prescribe for Sara and why? (Give examples of the foods you have chosen)

(vi) Calculate Sara's total energy requirements for weight loss

Question Six

[20 marks]

Chanda was diagnosed with high blood pressure ten (10) years ago. He has recently been diagnosed with chronic renal failure and you have been called on the ward by the Doctor to provide nutritional advice.

- (i) Define chronic renal failure
- (ii) How do you think the high blood pressure may have resulted in kidney disease?
- (iii) Hyperphosphatemia and hyperkalemia are two key features seen in chronic renal failure.
 - i. Why is this so?
 - ii. Provide nutritional therapies that you would advise Chanda to follow in practice in order to control the high levels of phosphorous and potassium
- (iv) The DASH diet is highly recommended for hypertension. Would this also be recommended for Chanda who now has chronic renal failure? Explain your answer in detail using nutrition principles for both hypertension and kidney disease
- (v) If you were to determine Chanda's total energy needs, what factors would you need to take into consideration to determine his total energy needs for weight loss? (He is mobile around the ward)

THE END

Annex

Table 1: Schofield Prediction Equations

Age range (years)	BMR (kcal/24 hours)	
	Males	Females
10 - 17	$(17.7 \times \text{kg body wt}) + 657$	$(13.4 \times \text{kg body wt}) + 692$
18 - 29	$(15.1 \times \text{kg body wt}) + 692$	$(14.8 \times \text{kg body wt}) + 487$
30 - 59	$(11.5 \times \text{kg body wt}) + 873$	$(8.3 \times \text{kg body wt}) + 846$
60 - 74	$(11.9 \times \text{kg body wt}) + 700$	$(9.2 \times \text{kg body wt}) + 687$
75+	$(8.4 \times \text{kg body wt}) + 821$	$(9.8 \times \text{kg body wt}) + 624$

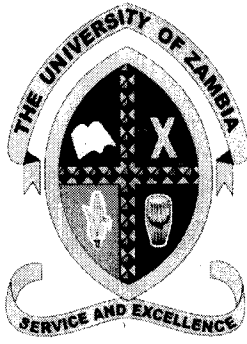

THE UNIVERSITY OF ZAMBIA
SCHOOL OF AGRICULTURAL SCIENCES
DEPARTMENT OF FOOD SCIENCE & NUTRITION

BSC HUMAN NUTRITION

AGN 4520 PUBLIC HEALTH NUTRITION

SUPPLEMENATRY EXAMINATION

DATE: 14TH FEBRUARY, 2022

TIME: 09:00 -10:30 HOURS

DURATION: 1 HR 30 MINUTES

VENUE: OMNIA 1

INSTRUCTIONS TO CANDIDATES:

1. THIS PAPER CARRIES 40 MARKS
2. THIS PAPER HAS THREE QUESTIONS. EACH QUESTION CARRIES 20 MARKS. ANSWER ANY TWO QUESTIONS

QUESTION ONE (20 MARKS)

- a. Discuss the relationship between nutrition and infection (**3 marks**)
- b. Discuss the effects of HIV/AIDS on nutrition and the effects of nutrition on HIV/AIDS (**8 marks**)
- c. Outline the goals of nutrition care and support in the management of HIV/AIDS (**6 marks**)
- d. Identify three (3) components of nutrition care and support (**3marks**)

QUESTION TWO (20 MARKS)

- a. State any four (4) methods of data collection used in Nutrition surveillance systems (**8 marks**)
- b. What do the letters HMIS stand for? (**2 marks**)
- c. List at least four (4) sources of HMIS data? (**4 Marks**)
- d. Outline any five (5) steps involved in the HMIS process (**5 marks**)
- e. State one way in which you would ensure quality of health care data (**1 mark**)

QUESTION THREE (20 MARKS)

- a. State the five (5) approaches to public health nutrition and one intervention under each of the five approaches. (**10 marks**)
- b. Explain the three (3) major interventions that can be used to control Soil Transmitted Helminths (STHs) (**3 marks**)
- c. What two (2) diseases are transmitted and spread through human waste? (**2 marks**)
- d. In Zambia, there are supplementation programs to address nutrient deficiencies of public health significance. List two (2) micronutrient deficiencies of public health significance in Zambia that the supplementation programs target. (**2 marks**)
- e. State **TWO (2)** consequences of micronutrient deficiencies for children 6-59months? (**2 marks**)



SCHOOL OF AGRICULTURAL SCIENCES
DEPARTMENT OF FOOD SCIENCE AND NUTRITION
HOSPITAL DIETARY MANAGEMENT - AGN 5432
END OF THE YEAR EXAMINATION

DURATION: THREE HOURS (3 HRS)
2022

DATE: Tuesday, 1st November

TIME: 14:00 to 17:00HRS

VENUE: OMNIA 2

INSTRUCTIONS

- 1. ANSWER ALL QUESTIONS**

1. You are a Dietician and oversees the National Hospital Dietary Services department (NHDS) at the Ministry of Health Headquarters, Ndeke office. On your routine countrywide monitoring and evaluation of nutrition service activities of all tertiary hospitals with a bed capacity of above 250, you encounter reliable distressing information from the general public and members of staff. All the facilities countrywide currently, are subjecting patients to poor and unacceptable dietary services at all levels. Your supervisor, the Director of clinical services is also concerned with your report. He ask your team to convene an adhoc meeting to address part of the problems highlighted in your report.

Concisely elaborate how you will address each gap listed below. **(30 marks)**

1. Unclear objectives of the service
 2. Questionable food preparation procedures
 3. Meals served cold and delayed
 4. Human resource management (Unqualified workers, No schedules, Not following disciplinary procedures, Workers not motivated, local leadership crisis)
 5. Unsystematic distribution of food
 6. Meal time setup for patients
 7. There is wastage of food both at the wards and kitchen
 8. There is evidence of worker pilfering food stuffs
 9. Undocumented food stuff in the storeroom
 10. Obsolete utensils and equipment
 11. Workers using bare hands and lack of safety gear for operations
 12. Mixing of raw and cooked foods, Kitchen not following a clear setup
 13. Foods served not documented
 14. Workers have not undergone medical examination in the past 2 years.
 15. The hospital management not clear whether the business is making profits or losses (The accountant complains of spending too much on the service and suggest part of the monies be spent on surgical consumables)
2. Nutrition care is a complex activity in health facilities, it is advised that health care professionals deliver care in a team approach. Imagine you are the Head Dietician for facility X, briefly discuss how you would mobilize resources to address one complicated renal case requiring your services in a Renal Unit. **(30 marks)**
3. A 55 year old male with a medical diagnosis of heart failure (diagnosed 2 months prior) retired engineer, lives alone in an apartment, height: 1.78m ; weight: 47Kg . weight loss of 5Kg from dyspnea, inability to consume large meals unable to shop or cook, 24-hour recall indicates he uses many frozen and processed foods; intake between 1000 – 1200 kcal/day. **(30 marks)**

- a. Using the Nutrition diagnostic terminologies, what domains are critical in the documentation of this patients care.
 - b. Make short nutrition notes using the SOAP style of documentation.
 - c. What are your two priority nutrition diagnosis for this patient.
 - d. Document your discharge notes for this patient.
4. You are approached by an enthusiastic matron in-charge of the hospital admission ward, who engages you to consider improving your services after her recent exposure during her visit to Kenyatta National Hospital (KNH). She informs you that at KNH, nutritionists subject each and every patient passing through the admission ward to a nutrition screening tool. This tool helps nutritionists determine whether patients may require further nutrition address whilst in admission. She then shares a copy of this tool for your study and reference.

Describe all the processes and details critical to the successful implementation of this tool at your hospital. **(30 marks)**

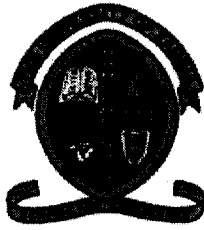

THE UNIVERSITY OF ZAMBIA
SCHOOL OF AGRICULTURAL SCIENCES
DEPARTMENT OF FOOD SCIENCE & NUTRITION

BACHELOR OF HUMAN NUTRITION

OBSTETRICS AND PEADIATRIC NUTRITION

AGN 5442

2021/22 END OF YEAR EXAMINATIONS

DURATION: THREE HOURS

VENUE: OMNIA 2

DATE: FRIDAY, 18th NOVEMBER 2022 NUMBER OF STUDENTS: 04

INSTRUCTIONS TO THE CANDIDATES:

1. PLEASE READ THE INSTRUCTIONS CAREFULLY.
2. THIS PAPER HAS FOUR QUESTIONS.
3. ANSWER ALL QUESTIONS.
4. EACH QUESTION CARRIES 20 MARKS.

Question One (20 marks)

Chanda is an 8 year-old boy who is admitted to Kabwe General Hospital for severe acute malnutrition (SAM). He has been in hospital for nearly 6 days and is showing signs of improvement. Chanda has been managed medically and nutritionally through provision of specialized feeds. The Doctor is optimistic of discharging Chanda very soon. Answer the following questions.

- (a) Define the following terms
 - (i) Severe acute malnutrition [3 marks].
 - (ii) Global Acute Malnutrition [2 marks].
- (b) What is the admission criteria into a malnutrition ward [1 mark].
- (c) What do you understand by “Reductive Adaptation” [4 marks].
- (d) Giving iron early in the treatment of SAM can lead to ‘free iron’ in the body. Explain how free iron can cause some problems in the body. [3 marks].
- (e) Why should a child with SAM be given potassium and magnesium? [2 marks].
- (f) Why should all children with SAM be given antibiotics? [1 marks]
- (g) What is the compositional difference between F-75 and F-100 [4 marks].

Question Two (20 marks)

- (a) Describe some diseases of preterm infants [6 marks].
- (b) Explain the conditions in which fluid restriction is allowed in pre-term infants [4 marks].
- (c) Why is insensible water loss highest in the smallest and least mature infants [4 marks].
- (d) What are some of the consequences of excessive fluid intake among preterm infants [3 marks].
- (e) How can one prevent hyperglycemia in Very Low Birth Weight infants [3 marks].

Question Three (20 marks)

- (a) In relation to intrauterine growth charts, explain the classification of infants [6 marks].
- (b) Why do you think low birth infants are at higher risk for poor nutrition status? [4 marks].
- (c) Explain the benefits of feeding premature infants with breast milk [3 marks].

- (d) Contrast the consequences of inadequate and excessive fluid intake in low birth weight infants [6 marks].
- (e) The energy needs of preterm infants fed parenterally are less than those of enterally fed infants (True or False) [1 mark].

Question Four (20 marks)

- (a) Define the following terms;
- (i) Low birth weight [1 mark].
 - (ii) Very low birth weight [1 mark].
 - (iii) Extremely low birth weight [1 mark].
 - (iv) Pre-term infant [2 marks].
 - (v) Term infant [2 marks].
 - (vi) Post-term infant [2 marks].
- (b) Describe some of the roles of a neonatal nutritionist or dietitian deployed to work in a neonatal unit [8 marks].
- (c) What are some of the causes of low birth weight? [3 marks].

THE END



SCHOOL OF AGRICULTURAL SCIENCES
DEPARTMENT OF FOOD SCIENCE AND NUTRITION
NUTRITION IN GENERAL MEDICINE - AGN 5452
END OF THE YEAR EXAMINATION

DURATION: THREE HOURS (3 HRS)

DATE: 4th November, 2022

TIME: 09:00 – 12:00HRS

VENUE: OMNIA 1

INSTRUCTIONS

- 1. ATTEMPT ANY FOUR QUESTIONS**

REMINDER: ATTEMPT ANY FOUR QUESTIONS

Question 1 (20 marks)

Chabota is a 12-year-old girl who was diagnosed with type 1 diabetes 2 years ago. She practices intensive therapy and has had the support of her parents (the Hamweetes) and an excellent diabetes management team. With their help, Chabota has been able to assume the bulk of the responsibility for her diabetes care and has managed to control her blood glucose remarkably well. In the past few months, however, Chabota has been complaining bitterly about the impositions diabetes has placed on her life and her interactions with friends. Sometimes she gets frustrated to a point of refusing to monitor her blood glucose levels, and she has skipped insulin injections a few times. Recently Chabota was admitted to the emergency room complaining of fever, nausea, vomiting and intense thirst. The Physician noted that Chabota was confused and lethargic. A urine test was positive for ketones, and her blood glucose levels were 22mmol/dl. The medical diagnosis was diabetic ketoacidosis (DKA).

1. Describe the metabolic events that lead to ketoacidosis.
2. Comment about Chabota's symptoms and laboratory test if consistent with the medical diagnosis.
3. What would you consider as intensive therapeutic measures for Chabota's condition?
4. List three motivational suggestions you will consider for Chabota's therapy because of her age for prudently managing her hyperglycemia.
5. How might you explain the importance of glycemic control to a 12-year old girl?
6. Describe the complications associated with long term diabetes.

Question 2 (20 marks)

Mutale is a 41 year old woman diagnosed with type 2 diabetes. Mutale developed gestational diabetes while she was pregnant with her second child. Her blood glucose levels returned to normal following delivery, and was advised to get regular checkups, maintain a desirable weight, and engage in regular physical activity. Although she reports that she does not overeat and that she exercises regularly, she has been unable to maintain a healthy weight. At 163cm tall, Mutale currently weighs 120Kg. The physician referred her to a Dietitian to help her weight management goals.

1. What factors in Mutale increase her risk for diabetes?

2. Imagine Mutale is showing signs of glucose intolerance and you feel at this stage her condition is reversible, devise a detailed therapeutic plan you will recommend for Mutale.
3. You realize her glucose levels persist and physician recommends for pharmacology intervention, describe the mechanism of action of three types of oral drugs for Mutale.
4. Comment on self-management trainings for Mutale.

Question 3 (20 marks)

Robert Mwanza, a 48 year old expert in bioinformatics is 1.65m tall and weighs 120Kg. He sits for long hours at work and is too tired to exercise when he gets home at night. His meals usually include fatty meat, eggs and cheese, and he likes dairy desserts such as pudding and ice cream. He has a family history of CHD and hypertension. His recent laboratory tests show that his blood pressure is 160/100mm Hg, and his LDL and HDL levels are 160 mg/dL and 35 mg/dL, respectively. He smokes a pack of cigarettes each day and usually has two glasses of wine at both lunch and dinner.

1. Identify Mr. Mwanza's major risk factors for CHD and hypertension. Which can be modified? What complications might occur if he delays treatment for his blood lipids and blood pressure?
2. What dietary changes would you recommend that could help to improve Mr. Mwanza's blood pressure and LDL cholesterol level? Explain the rationale for each dietary change.
3. Prepare a day's menu for Mr. Mwanza using the DASH Eating plan as an outline for your choices.
4. What other laboratory tests or measurements would you need to better assess Mwanza's condition? and Why?
5. Describe several benefits that Mr. Mwanza might obtain from a program that includes weight reduction and regular physical activity.
6. Explain why the use of alcohol can be both protective and damaging lifestyle habit.

Question 4 (20 marks)

Thomas is a 55 year old banker who developed chronic kidney disease as a result of hypertension. His condition was discovered several years ago, when routine laboratory tests revealed elevated serum creatinine levels and persistent albuminuria. Since then, he has been taking antihypertensive medications and restricting dietary sodium, but he reported difficulty following the low protein diet that was also

prescribed. Recently, he reported low urine output and neuropathy in the hands and feet. Also reported feeling drowsy at work and bruising more than usual. He also observed swelling of his ankles and feet. Test revealed a GFR had fallen to 10 milliliters per minute.

1. Based on GFR staging, describe progression of CKD.
2. What happens to creatinine and albuminuria as renal function declines?
3. Describe clinical effect you would expect during the final stage of disease, when kidney failure develops.
4. What energy and protein intakes would you recommend for Thomas? (use hypothetical data)
5. You consider renal replacement therapy for Thomas, describe the two options for this therapy.
6. What would change in your energy and protein intake recommendation for Thomas.

Question 5 (20 marks)

A 35 year old woman presents to the emergency department with history of diarrhoea and vomiting. She was recently started on furosemide (Lasix) as treatment for her hypertension. You are called to help manage the patient.

1. List 3 properties of cardiac cells
2. With the aid of a diagram, show how the ECG will depict a person with
(i) **hyperkalaemia** (ii) **hypokalaemia**.
3. What abnormalities do you expect to see on her laboratory results?
4. What are the main clinical signs related to a diagnosis of metabolic syndrome.
5. Congestive cardiac failure (CCF) is a serious complication in adults especially women in Zambia. What are the main clinical characteristics of CCF?
6. Elaborate what is involved in nutrition management of CCF.



THE UNIVERSITY OF ZAMBIA
SCHOOL OF AGRICULTURAL SCIENCES
DEPARTMENT OF FOOD SCIENCE & NUTRITION

BACHELOR OF HUMAN NUTRITION

NUTRITION IN ONCOLOGY, TRAUMA AND SURGERY

AGN 5462

2021/22 END OF YEAR EXAMINATIONS

DURATION: THREE (03) HOURS

VENUE: OMNIA 1

DATE: FRIDAY, 11th NOVEMBER 2022

TIME: 14 – 17 HOURS

NUMBER OF STUDENTS: 04

INSTRUCTIONS TO THE CANDIDATES:

1. PLEASE READ THE INSTRUCTIONS AND EACH QUESTION CAREFULLY.
2. THIS PAPER HAS FOUR QUESTIONS
3. ANSWER ALL QUESTIONS
4. EACH QUESTION CARRIES 25 MARKS.

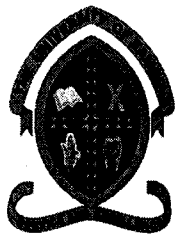

**THE UNIVERSITY OF ZAMBIA
SCHOOL OF AGRICULTURAL SCIENCES
DEPARTMENT OF FOOD SCIENCE & NUTRITION**

**BSc HUMAN NUTRITION
AGN 5542: WORLD FOOD ISSUES**

2021/2022 ACADEMIC YEAR

DATE: 11/11/2021

DURATION: THREE (3) HOURS

TIME: 14.00 – 17.00 HOURS

VENUE: OMNIA 2

INSTRUCTIONS TO CANDIDATES:

- 1. THIS PAPER CARRIES 60 MARKS. ANSWER ALL THE QUESTIONS.**
 - 2. ALLOCATED MARKS FOR EACH QUESTION ARE INDICATED IN BRACKETS**
-

SECTION A: ANSWER ALL QUESTIONS (30 MARKS)

1. Briefly explain what the global food security index is and what indicators are used in its calculation
(5 marks)
2. List any five (5) negative impacts of agricultural technologies. (5 marks)
3. List any five (5) sources of data where food and nutrition information/data can be accessed from.
(5marks)
4. List any four (4) districts in Zambia where the scaling up nutrition (SUN) programme is being implemented and briefly explain the focus of SUN II programme in Zambia (5 marks)
5. List any five stakeholders that influence the direction of food and nutrition policy discussions in Zambia.
(5 marks)
6. Briefly describe the link between trade and food security. (5 marks)

SECTION B: ANSWER ALL QUESTIONS (30 MARKS)

Question 5

Discuss how the following factors can influence food and nutrition security of a country. (15 marks).

- a. Environmental factors
- b. Health factors
- c. Social factors

Question 6

- a. Discuss policies that aim at reducing inequalities and raising incomes of the poor in a country.
(10 marks)
- b. Explain how the following policies/ legislations influence food and nutrition security in Zambia.
 - i) Maternity Protection Law CAP 268 of the Laws of Zambia (1 mark)
 - ii) Employment Act (2 marks)
 - iii) The Food and drug Act (2 marks)

Instructions: There are four questions in this examination. Answer all of them.

Question One [25 marks]

Limpo is a 27 year old lady admitted to the ICU at Levy Mwanawasa Teaching Hospital. She was hit by a car and sustained a broken jaw. The medical team managed to immediately resuscitate her with normal saline and operated on her five days later. She has not had any oral feeds the past 10 days. Considering the fact that the patient is hemodynamically stable, the Senior Doctor writes a consultation to your office for appropriate dietetic advice.

Address the following;

- (i) Which aspects of the patient's body would you focus on in order to determine the nutritional status based on physical assessment? [5 marks].
- (ii) Describe re-feeding syndrome? [5 marks].
- (iii) Based on your expert opinion, explain why the patient may be at risk of re-feeding syndrome? [3 marks].
- (iv) Justify the type of route to use for feeding the patient [2 marks].
- (v) Explain the purpose of diet modification [5 marks].

Question Two

[25 marks]

A newly recruited nutrition technologist is deployed to Kaputa General Hospital. Upon arrival she is oriented to the hospital health care team which is keen on screening the patients on the wards. The nutrition technologist is tasked to devise a nutrition screening protocol for the hospital. Answer the following questions

- (i) Why is nutrition screening performed? [2 marks].
- (ii) Identify common nutrition screening parameters [4 marks].
- (iii) Explain the qualities of a well-designed nutrition screening tool [5 marks].
- (iv) What is a nutrition care process? [4 marks]
- (v) Give examples of nutrition interventions [4 marks].

(vi) What is the difference between a nutrition and medical diagnosis? [2 mark].

(vii) Mention the common nutrition diagnoses? [4 marks].

Question Three

[25 marks]

(i) Explain the multi-stage process involved in the development of cancer [6 marks].

(ii) Why are cancer patients likely to suffer from vitamin and mineral deficiencies [5 marks].

(iii) What is the role of counter-regulatory hormones such as glucagon and cortisol [2 marks].

(iv) "Metabolic response to critical illness is very different from simple or uncomplicated starvation". Explain the statement [6 marks].

(v) Why is it important to avoid overfeeding critically ill patients [4 marks].

(vi) What is the rationale of the surgical practice of requiring Nothing By Mouth [2 marks].

Question Four

[25 marks]

(i) Weight change over a period of time might be more useful than mere weight in the evaluation of a patient's nutrition status. Discuss this statement [3 marks].

(ii) Dehydration is prevalent in many cancer patients, especially those who receive chemotherapy and/or radiation therapy. Hence high-risk patients should be closely monitored for signs and symptoms of dehydration. Give examples of these symptoms [4 marks].

(iii) "Hepatic transport proteins are markers of nutritional status in oncology patients" is the screaming headline on social media made by some renowned nutritionist. What is your comment? [4 marks].

(iv) Discuss some of the risk factors associated with Head and Neck Cancers [6 marks].

- (v) As a Nutrition Professional working at Cancer Disease Hospital, what are some of the key issues you would take into account in the general management of cancer patients [3 marks].
- (vi) What factors are considered in the Medical Nutrition Therapy of cancers of the stomach? [2 marks].
- (vii) Patients with carcinomas of the stomach may sometimes undergo gastric surgery which may result in iron deficiency. Give a possible explanation for this deficiency [3 marks].

THE END

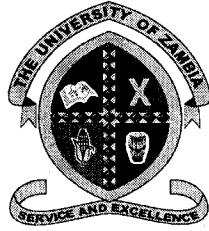

THE UNIVERSITY OF ZAMBIA
SCHOOL OF AGRICULTURAL SCIENCES
DEPARTMENT OF FOOD SCIENCE AND NUTRITION

2021/2022 ACADEMIC YEAR
MID-YEAR EXAMINATION

COURSE: AGN6111
Advanced Metabolism

Date: 13th JUNE 2022

Time: 09 00 – 12 00 hours

Duration: THREE (3) HOURS

**Venue: FSN 2 (MSc LECTURE
ROOM)**

INSTRUCTIONS TO CANDIDATES:

- 1. This paper consists of Section A and Section B.**
 - 2. Please read the guidance for each section carefully.**
 - 3. All four (4) questions in section A are compulsory and marks allocated to each question are shown in parenthesis against the question.**
 - 4. All questions in Section B carry twenty (20) marks each. Answer ANY two (2) questions only.**
-

SECTION A

Section A has a total of **four (4)** questions and this section accounts for **sixty (60)** marks in this question paper.

Answer **ALL** questions in this section

Question 1

- a) Define glycolysis. What inhibits glycolysis? (5 marks)
- b) How many ATP are required for glycolysis and how many are produced during glycolysis?
What is the net gain of ATP? (3 marks)
- c) Explain why ATP is important in metabolism. Give two (2) reasoning. (4 marks)
- d) Explain how ATP is used. (3 marks)

Question 2

- a) Discuss the basic **structure** of protein (3 marks)
- b) How do our bodies prevent our digestive enzymes from digesting the cells that produce them (2 marks)
- c) Explain what is understood by the term 'nitrogen balance'. (2 marks)
- d) Identify two (2) causes of positive nitrogen balance and two (2) causes of negative nitrogen balance. (3 marks)
- e) Explain the importance of transamination and deamination during protein metabolism (5 marks)

Question 3

- a) Summarise the role of leptin in the regulation of food intake (4 marks)
- b) Summarise the nature and effect of insulin in the regulation of food intake (4 marks)
- c) Define energy balance and list the components of energy balance (4 marks)
- d) Summarise the changes in body composition that occur from infancy until old age (3 marks)

Question 4

- a) Define free radicals. Explain how they are formed in the body and how they affect health. **(5 mark)**
- b) Give two (2) examples of vitamins and /or minerals that can remove free radicals and explain in brief how they do it. **(2 mark)**
- c) Give two (2) vitamins and two (2) minerals that you would recommend for a pregnant woman and give your reasoning. **(8 mark)**

SECTION B

Section **B** has a total of **three (3)** questions and this section accounts for **forty (40) marks** in this question paper.

Answer **ANY TWO (2)** questions in this section

Each question carries 20 marks.

Question 5

Summarise events that are involved in the digestion (**including site, action, enzymes**), and absorption of protein **(10 marks)**

AND

Briefly explain how muscle protein breakdown is slowed down in prolonged starvation **(10 marks)**

OR

Briefly describe the processes that occur during the post-absorptive (fasted) state of metabolism **(10 marks)**

Question 6

Identify the general biological characteristics of vitamins and list four (4) physiological processes that depend on vitamins with examples of the vitamin. Discuss two (2) causes of vitamin deficiency and briefly describe two (2) strategies, at the national level, for reducing the risk of vitamin deficiency in the population. **(20 marks)**

Question 7

In brief, describe how feeding is a complex pattern of behaviours. State and explain **two (2)** physiological, and **two (2)** economic and/or social cultural factors that influence our food choices. **(10 marks)**

AND

Define minerals and describe the characteristics of minerals in nutrition. List four (4) essential roles of minerals in the body and list three (3) foods that are good sources of minerals **(10 marks)**

OR

Fatty acids are vulnerable to oxidative damage, explain how humans and other warm-blooded organisms store fat in their bodies. What are Trans fatty acids and why are Trans fatty acids considered harmful to nutritional health? Give a thorough biochemical explanation as to why food rich in fats provides more energy to the body than food rich in carbohydrates. **(10 marks)**

END OF EXAMINATION



**THE UNIVERSITY OF ZAMBIA
SCHOOL OF AGRICULTURAL SCIENCES
DEPARTMENT OF FOOD SCIENCE & NUTRITION**

MSC HUMAN NUTRITION PROGRAMME

AGN 6210 BIOSTATISTICS AND RESEARCH METHODS

2021-2022

DATE: 4 NOVEMBER 2022

TIME: 09:00-12:00

DURATION: THREE HOURS

VENUE: FSN3 MSc CLASSROOM

INSTRUCTIONS TO THE CANDIDATES

- 1. THIS PAPER HAS THREE SECTIONS: A, B AND C.**
 - 2. ANSWER ALL QUESTIONS IN ALL SECTIONS**
 - 3. WRITE EACH SECTION IN A SEPARATE BOOKLET**
 - 4. WRITE EACH QUESTION ON A SEPARATE PAGE**
 - 5. MARKS FOR EACH QUESTION ARE INDICATED IN PARENTHESIS**
-

SECTION A: BIOSTATISTICS PART 1

QUESTION 1 (16 MARKS)

An experiment was conducted to compare the effects of rearing chicks (a) in confinement and (b) on open range. One batch was reared under each system. At 5 weeks of age a sample of 10 chicks was taken from each batch and each individual was weighed (Table 1)

Table 1. Weight gains of chicks reared in confinement A and on open range B (00's gm)

Series A	Series B
9	8
17	15
14	11
13	10
15	9
10	12
11	11
13	10
13	9
15	15

Determine whether there was any significant difference between the methods of rearing chickens

QUESTION 2 (14 MARKS)

A dice is tossed 36 times and the observed results are as shown below (Table 2):

Table 2: Observed results of the tossed dice

Outcome	Observed
1	5
2	8
3	4
4	7
5	6
6	6

- a) Test the null hypothesis that there is no difference between the observed and expected values **[10 Marks]**
- b) Interpret the result in (a) **[4 Marks]**

SECTION B: BIOSTATISTICS PART 2

QUESTION 3 (20 MARKS)

You are presented with a Stata dataset on rural households in Zambia that has variables as defined in Table 3:

Table 3: Variable names and definitions

variable name	variable label/definition
prov	categorical variable for provinces in Zambia
num_members	number of members in each household
eduhead	Level of education of household head in years
malehead	=1 if household is headed by a male member
headage	Age of the household head
hect_cult	Land cultivated by each household
TLU	Tropical Livestock Units
fisp	=1 if household received Farmer Input Support Programme inputs
foodneedHH	Number of months when household had inadequate food provisions
num5HH	number of children under five in each household

- a) Write down the Stata command to generate summary statistics for the three variables: (i) num_members; (ii) hect_cult; (iii) foodneedHH. **[1 mark]**
- b) State and interpret the standard deviation and range for each of the three variables reported in Table 4. **[6 marks]**

Table 4: Summary statistics

VARIABLES	N	mean	Std dev	minimum	maximum
num_members	7,925	6.25	2.75	1	24
hect_cult	7,925	2.41	2.44	0	45.25
foodneedHH	3,284	3.68	1.74	1	12

- c) Write down the Stata command to generate summary statistics for the variable foodneedHH disaggregated by province. **[1 mark]**

- d) Briefly analyze and discuss the results of the summary statistics for the variable foodneedHH disaggregated by province presented in Table 5. [4 marks]

Table 5: Summary statistics of FoodneedHH by Province

Province	Mean of FoodneedHH	Standard deviation of FoodneedHH
Central	3.25	1.44
Copperbelt	3.27	1.15
Eastern	3.08	1.36
Luapula	4.01	1.72
Lusaka	3.28	1.44
Muchinga	4.01	1.73
Northern	3.28	1.77
North Western	3.95	1.99
Southern	4.05	2.04
Western	4.71	1.99

- e) Write down the Stata command to estimate a multiple linear regression model with foodneedHH as the dependent variable and the following as independent variables: (i) eduhead; (ii) malehead; (iii) headage; (iv) hect_cult; (v) TLU; (vi) fisp; (vii) num5HH. [1 mark]
- f) The regression output is reported in Table 6:

Table 6: Regression estimates of foodneedHH on several factors

<i>Number of observations</i>	1,945
<i>R-squared</i>	0.209
<i>F(7, 1937)</i>	5.96
<i>Prob > F</i>	0.000

Explanatory variables	Coefficients	p-values
eduhead	0.010	0.409
malehead	-0.210	0.042
headage	0.006	0.053
hect_cult	0.007	0.768
TLU	-0.010	0.225
fisp	-0.472	0.000
Num5HH	0.028	0.601
Intercept	3.605	0.000

- i. Are the explanatory variables jointly significant at 1% level of significance? State the relevant hypothesis test and interpret the relevant statistic. [3 marks]
- ii. At 10% level of significance, does Num5HH have any effect on foodneedHH? State the relevant hypothesis test, interpret the relevant statistic and explain the effect of Num5HH have on foodneedH. [4 marks]

SECTION C: RESEARCH METHODS

QUESTION 4 (25 MARKS)

There is strong evidence that consumption of red meat (e.g beef, pork and sheep) increases the risk of colorectal cancer (cancer of the large intestine and rectum).

- a) Using an appropriate study design explain how you can establish that consumption of processed meat is associated with colorectal cancer incidence. Include an appropriate hypothesis. **[10 marks]**
- b) Briefly describe limitations of the study design in (a). **[5 marks]**
- c) From the figure below, interpret the findings from a study by Chan et al. (2011) on Red and Processed Meat and Colorectal Cancer Incidence. **[5 marks]**

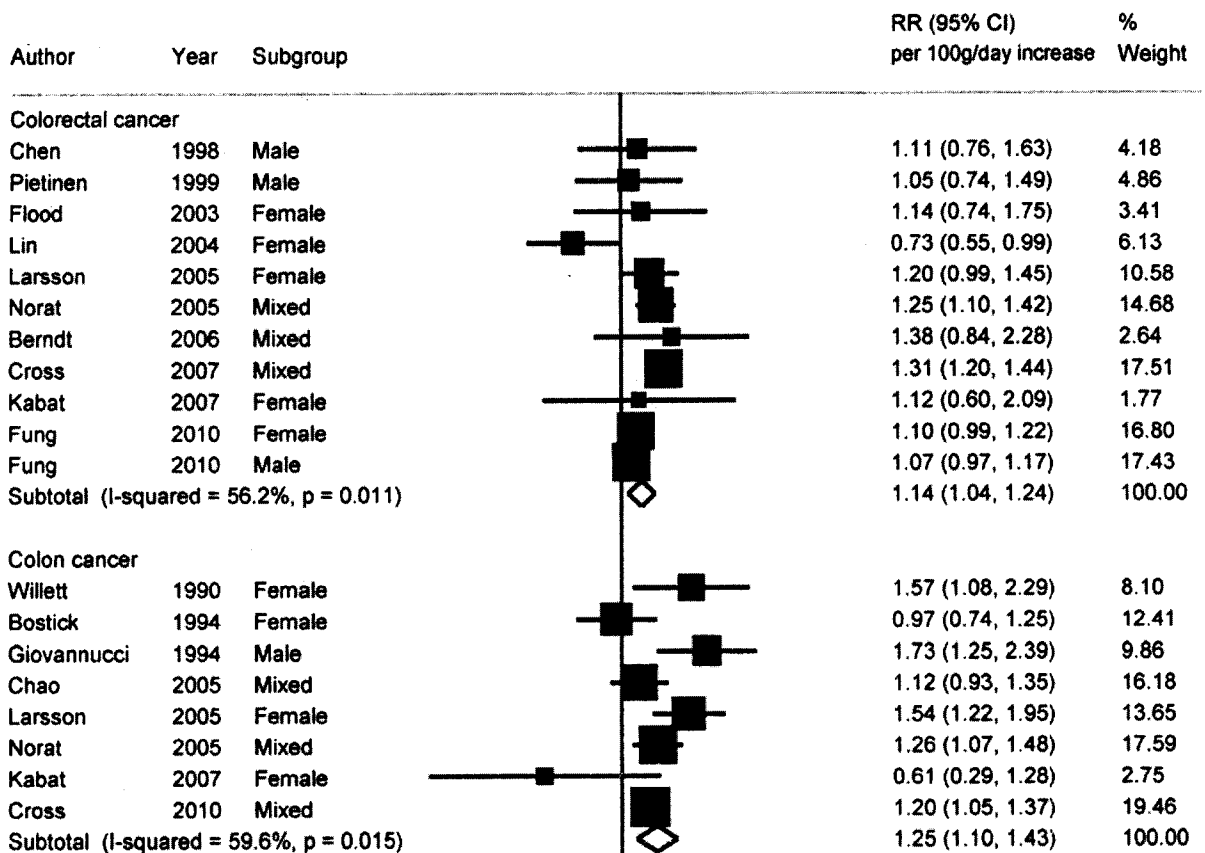

- d) Identify and briefly explain the three basic approaches for controlling for confounding in biological sciences research **[5 marks]**

QUESTION 5 (25 MARKS)

Researchers from social and biological sciences more often than not have to use a sample in their respective study fields.

- a) Define a sample using a relevant example. **[2 marks]**
- b) Give three main reasons for using a sample in research. **[6 marks]**
- c) Differentiate sampling error from a sample frame. **[2 marks]**
- d) Identify and briefly describe the two main types of sampling, in your response explain the justification for selecting either of the two approaches in research. **[10 marks]**

QUESTION 6 (5 MARKS)

List five steps in conducting literature reviewing **[5 marks]**



**UNIVERSITY OF ZAMBIA
SCHOOL OF AGRICULTURAL SCIENCES
FOOD SCIENCE AND NUTRITION DEPARTMENT**

2021/2022 ACADEMIC END OF YEAR EXAMINATIONS

**AGN 6410
SOCIOECONOMIC DIMENSIONS OF NUTRITION**

**Date: 31/10/2022
Time: 09:00 Hours – 12:00 Hours
Venue: MSC LECTURE ROOM, FS**

Duration: THREE (3) HOURS

INSTRUCTIONS TO THE CANDIDATES

- 1. THIS PAPER HAS TWO SECTIONS: A AND B.**
- 2. ANSWER ALL THE QUESTIONS IN BOTH SECTIONS**
- 3. ALLOCATED MARKS FOR EACH SECTION ARE INDICATED IN THE BRACKETS**

SECTION A (30 MARKS)

1. What is Nutrition Transition and list any 2 things that have contributed to nutrition transition **[3 marks]**
2. How does food distribution affect food access? **[3 marks]**
3. Give any 3 reasons why food balance sheets are useful **[3 marks]**
4. A household's vulnerability to hunger (due to climate change) must consider at least three factors. What are they? **[3 marks]**
5. What is an obesogenic environment and list three causes of an obesogenic environment. **[4 marks]**
6. Give one health consequence of an obesogenic environment. **[1 mark]**
7. Explain how the socio-economic status affects access to food in terms of advertising **[2 marks]**
8. Trade policies are important as they may affect food access. List three primary functions of tariffs **[3 marks]**
9. Why is the "carrying capacity of land" important in terms of nutrition? **[2 marks]**
10. Discuss any three ways of how population growth may affect nutrition **[3 marks]**
11. What are food crops and what is their role in nutrition **[3 marks]**

SECTION B (70 MARKS)

1. Regarding Gender, early marriages and nutrition, answer the following.
 - a. In relation to the importance of gender equality, why is a woman's health important? **[4 marks]**
 - b. Why does gender matter in nutrition? **[5 marks]**
 - c. Why is adolescent pregnancy bad for both the adolescent mother and her baby? **[5 marks]**
 - d. List three consequences of early marriages. **[3 marks]**
 - e. Name any three interventions that can be put in place to prevent early marriages. **[3 marks]**

2. Regarding global health, answer the following questions.
 - a. Differentiate between global and international health **[1 mark]**.
 - b. What are the 6 key concepts in relation to global health? **[9 marks]**
 - c. List any 5 determinants of health **[5 marks]**
 - d. Imagine that you are the health minister and have just been awarded a huge grant by the World Bank. The grant is to tackle the most pressing health problem in the country. How do you decide how to prioritise disease X over disease Y, Y over disease Z? And how will you go about finding a solution to the problem? **[5 marks]**

3. Regarding social protection, answer the following questions.
 - a. Food transfers are one of the social protection instruments, what is the main aim of food transfers **[2 marks]**?
 - b. What are the three major methods for food transfers **[3 marks]**
 - c. What are the aims of social protection in Zambia **[4 marks]**
 - d. Discuss any 5 key principles for making social protection more nutrition-sensitive **[15 marks]**
 - e. Briefly Discuss cash transfers in light of improving nutritional status **[6 marks]**

UNIVERSITY OF ZAMBIA
SCHOOL OF AGRICULTURAL SCIENCE
FINAL EXAMINATIONS NOVEMBER 2022
AGS 2110
FUNDAMENTALS OF SOIL SCIENCE

TIME: 3.0 HOURS

**INSTRUCTIONS: ANSWER FOUR QUESTIONS
ALL FROM SECTION A AND ONE FROM SECTION B**

MARKS: 100

SECTION A ANSWER QUESTIONS 1, 2 AND 3

1. Define the following terms: (15 marks)

- a. Pedology
- b. Physical weathering
- c. Soil Structure
- d. Sand as a particle size
- e. Air filled porosity
- f. Dispersion of soil colloids
- g. Variable charge
- h. 1: 1 layer silicate
- i. Secondary mineral
- j. Histosols

2. Indicate whether the following statements are True (T) or false (F). (15 marks)

- a. More energy is required to extract gravitational water than hygroscopic water from soils.
- b. The value of the dry bulk density of a mineral soil is always less than the value its particle density.
- c. A soil containing 2.5 cmol (+)K /kg soil contains more potassium than one containing 500 mg k/ kg soil.
- d. Di-ammonium phosphate (DAP) $(\text{NH}_4)_2\text{HPO}_4$ is a Compound Fertilizer.
- e. Metallic micronutrients are generally more soluble in acid soils than in alkaline soils
- f. A soil containing 0.04 % N, has less N than a soil with 3 % Organic matter with a C: N ratio of 16:1.
- g. A sodic soil is more likely to have a higher Aggregate Instability Index than a normal soil
- h. Muscovite $(\text{KAl}_2(\text{Si}_3\text{Al})\text{O}_{10}(\text{OH})_2$ is a 2:1 layer silicate which is a primary mineral .
- i. Biological nitrogen fixation is a process that increases the amount of N available to plants.
- j. The plasticity of the soil is determined when the soil is dry.
- k. Uncultivated surface soil horizons usually contain more organic matter than subsurface soil horizons
- l. A soil with colour code of 10YR2/4 is darker than one with colour code of 10YR 6/8.
- m. Isomorphic substitution in minerals always results in the development of a net negative charge.
- n. Massive structure is an example of non-aggregated soil structure.
- o. Humus has both permanent and variable charges.

3. Answer the following questions: (35 marks)

- a. A soil has pores with the largest diameter of 40 μm filled with water. Answer the following: (6 marks)
- List and define the three components of the soil water potential of this soil and describe how these affect the total water potential of the soil. Give reasons why you picked on the three water components. (6 marks)
- b. Potassium, molybdenum, sulphur, and zinc are plant nutrient elements. Answer the following : (7 marks)
- Indicate the classification of these nutrients according to plant nutrition (2 marks)
 - Indicate the classification of the nutrients according to the fertilizer industry (3 marks)
 - Indicate the bioavailable forms of these nutrients (2 marks).
- c. Soils form as a result of the interaction of five factors which result in processes that lead to the formation of different soil horizons. Answer the following: (9 marks)
- List the five factors of soil formation and list and define the four major groups of soil forming processes. (5 marks)
 - If a soil profile has the soil horizons: Bt, C, A, O AB forms, sketch a diagram showing the order in which these horizons occur in the profile from the surface to the bottom of the profile and indicate the horizons that make up the solum (3)
 - What specific soil forming process results in the formation of the Bt horizon (1)
- d. Measurements are important in scientific studies. Answer the following: (7 marks)
- What are the following instruments and apparatus used to measure in soils:
(a) Tensiometer (b) Hydrometer (c) Measuring tape (d) pH meter (4 marks)
 - Briefly describe how the gravimetric moisture content of soil is measured in the laboratory and show the formula used to calculate the moisture content from the measurements obtained in the laboratory. (3 marks)
- e. Organic fertilizers are an important source of nutrients. Their performance in soils is related to the activity microorganisms in the soil, which are in turn affected by soil conditions and the properties of the organic material. Answer the following: (6 marks)
- Discuss three environmental factors or soil conditions that have an influence on the activity of microorganisms (3 marks)
 - Define the C: N ratio of soil organic material and describe how it influences the fate of nitrogen in the materials upon decomposition. (3)

SECTION B, ANSWER ONE QUESTION (EITHER 4 OR 5)

4. The physical properties of soils are important in the functioning of soils in the environment. Answer the following questions: (35 marks)

4a. A soil sample was obtained from a 25 cm thick surface horizon using a core ring with a height of 6 cm and internal diameter of 5 cm. The mass of soil in the core ring from the field was 170.0 g, while the oven dry mass was 165.0 g. Given that the particle density of the soil is 2.65 g.cm^{-3} , while the density of water is 1.0 g.cm^{-3} , and the gravimetric moisture contents are 9.9 % at permanent wilting point and 18 % at field capacity, answer the following: (22 marks)

- (i) What is the dry bulk density of this soil in kg.m^{-3} ? (3 marks)
- (ii) What was the gravimetric moisture content in percent of the soil obtained from the field? (3 marks)
- (iii) Was the soil sample obtained from the field dry, moist or wet? Give reasons to support your answer. (2.5 marks)
- (iv) What is the volumetric moisture content of this soil in $\text{cm H}_2\text{O.cm soil}^{-1}$ when it is saturated? (3 marks)
- (v) How many litres of air are present in one hectare of this soil, when the soil is at field capacity? (4 marks)
- (vi) What is the water-holding capacity of this soil in $\text{cmH}_2\text{O/cm soil}$? (2.5 marks)
- (vii) To what depth in centimeters would this soil layer be wetted by 15 mm of rainfall, if the initial moisture content is that of the sample obtained from the field? (4 marks)

4 b. If the bottom of the Goma lakes at UNZA has a 10 cm thick soil layer which has saturated hydraulic conductivity (K_{sat}) of $7.5 \times 10^{-8} \text{ m.s}^{-1}$ and the height of the water in the lake standing above this soil layer is constantly 50 cm, answer the following: (13 marks)

- a. Assuming the surface of the water in the lake is the reference level for the gravitational potential, calculate the Hydraulic heads (H) in metres at the top and bottom of the soil layer. (5 marks)
- b. What is the direction of water flow between the top and bottom of the soil layer? Give reasons to support your answer (3 marks)
- c. How many litres of water flow through a 25 m^2 area of this soil layer in one hour? Show the necessary calculations to support your answer. (5 marks).

5. Selected physical and chemical properties of a soil from a farmer's field in Sesheke are presented in the Table 1 below.

Depth	ρ_b	pH	Sand	Silt	Clay	OM	Total N	P	K	ECEC	BS
(cm)	g.cm^{-3}	0.01M CaCl_2	%			%	%	mg/kg	cmol(+)/kg		%
0-20	1.46	4.71	92.5	3.0	4.5	2.02	0.04	11.8	0.19	5.6	75

Answer the following questions: (35 marks).

- What figure in Table 1 represents the active acidity of this soil? (1 mark)
- Plot the percentages of sand, silt and clay in this soil horizon on the attached textural triangle and determine the textural class of this soil. (3 marks)
- Is this soil likely to have a high or low water holding capacity? Give reasons to support your answer. (3 marks)
- Would you expect high levels of activity of bacteria in this soil? Give reasons to support your answer. (2.5 marks)
- Calculate the exchangeable acidity of the soil in $\text{cmol}(+)\text{.kg soil}^{-1}$. (2.5 marks)
- Given that 50 g of pure CaCO_3 is required to neutralize 1 mole of acidity, how many kilograms of pure CaCO_3 are required to neutralize the exchangeable acidity in 1 hectare of this soil layer. (4 marks)
- Assuming that all the nitrogen in this soil is part of the organic matter (OM), would you expect nitrogen to be mineralized when the soil organic matter is decomposed? Show the necessary calculations to support your answer. (3 marks)
- How many kilograms of organic carbon are present in one hectare of this soil? (4 marks)
- A farmer wants to grow crop of maize whose seasonal nutrients requirements are 120 kg N/ha, 22 kg P/ha and 100 kg K/ha on this soil. If 3 % of total N is mineralized in one season, and if all available P and exchangeable K are readily available to the crop in one season, would the soil be able to meet these season requirements of maize per hectare for N, P and K? Show the necessary calculations used to determine the amounts of N, P and K the soil is able to supply in one season. Also show the balance between the crop requirement and what the soil is able to supply in one season for each nutrient. (12 marks).

Useful Data:

Molar masses: H= 1g, C=12 g, N = 14g, P= 31g, K= 39g, Ca= 40g, Mg=24g, Na=23g

END OF EXAM

SOIL SCIENCE IS FUN

AGS 2110 EXAM

COMPUTER NO:

TEXTURAL TRIANGLE FOR QUESTION 5b.

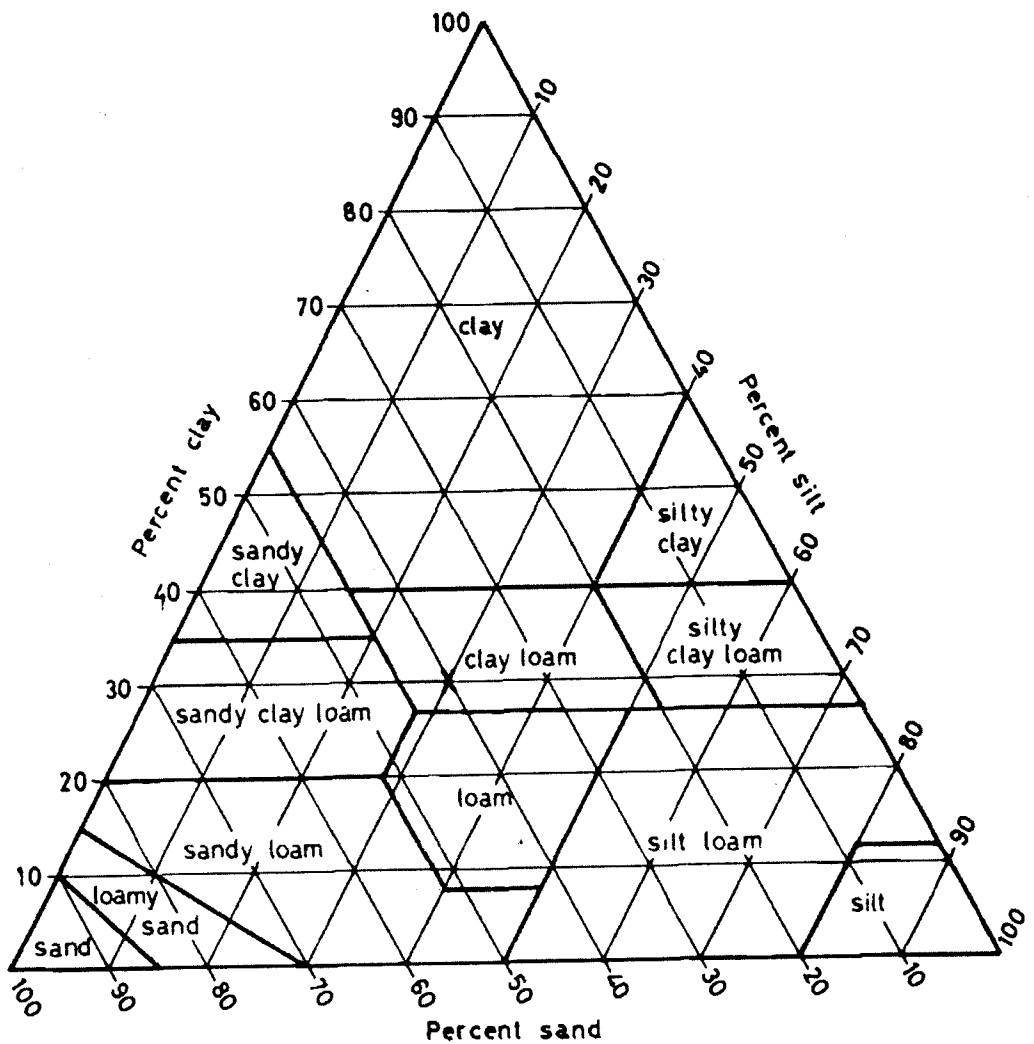

SUBMIT TOGETHER WITH ANSWER SHEET AS PART OF QUESTION 5.

UNIVERSITY OF ZAMBIA
SCHOOL OF AGRICULTURAL SCIENCES
DEPARTMENT OF SOIL SCIENCE
AGS 2110
FUNDAMENTALS OF SOIL SCIENCE
2020/21 SUPPLEMENTARY EXAMINATION

INSTRUCTIONS:
TIME: 2 HOURS

ANSWER 4 QUESTIONS
MARKS: 100

Section A: Answer all three questions in this Section

1. Define the following terms: (15 marks)
 - a. Soil parent material
 - b. Hydrometer
 - c. Anaerobic microorganism
 - d. Eluviation
 - e. Dry bulk density of soil
 - f. Field capacity
 - g. Sand as a particle size
 - h. Nitrogen fixation
 - i. Igneous rock
 - j. E-horizon

2. Indicate whether the following statements are true (T) or false (F) (15 marks)
 - a. The value of the particle density of a mineral soil is always greater than the value its dry bulk density when both are expressed in the same units.
 - b. A soil with a colour code of 7.5 YR 3/4 is redder than a soil with a colour code of 10YR6/3.
 - c. The Ap horizon usually occurs above the E-horizon
 - d. The fertilizer $\text{NH}_4\text{H}_2\text{PO}_4$ is a Compound fertilizer
 - e. The liming material $\text{CaMg}(\text{CO}_3)_2$ has a higher Neutralizing value than $\text{Ca}(\text{OH})_2$.
 - f. Quartz is harder than orthoclase
 - g. A soil with a dry bulk density of $1.5\text{g}/\text{cm}^3$ and a particle density of $2.65\text{g}/\text{cm}^3$ cannot have a volumetric moisture content of 50 %.
 - h. Mineral soils have parent materials that originate from rocks or minerals.
 - i. More energy is required to extract a kilogram of water from soil pores with a diameter of $50\ \mu\text{m}$ than to extract a kilogram of pure water from a 0.2 molal solution of CaCl_2 at 20°C .
 - j. Fungi, are better adapted to acid soil conditions than bacteria.

3. Answer the following questions: (30 marks)

- List and define the three components of the total water potential of a saturated soil. (7.5 marks)
- List any 3 macronutrients and any 3 micronutrients and (i) indicate their classification according the fertilizer industry and (ii) indicate their bioavailable forms (7.5 marks).
- Define the two major components of the total acidity of a soil. (5 marks)
- List and define the three main ways by which nutrients in the soils reach the surface of plant roots (6 marks)
- List the classes of soil microorganisms based on: (i) their source of carbon and (ii) their source of energy. (4 marks).

Section B: Answer one question from this Section.

4. Table 1 below presents a summary of properties of an Ap horizon from a farmer's field.

Depth	pH	Bd	Total N	Org C	Avail P	K	Al	ECEC	Sand	Silt	Clay
cm	0.01M CaCl ₂	g.cm ⁻³	%	%	mg.kg ⁻¹	cmol.kg soil ⁻¹			%	%	%
0-25	4.40	1.5	0.04	0.95	8.0	0.2	1.2	1.5	60	15	25

Answer the following: [40 marks]

- Plot the data for the percentages of sand, silt and clay on the USDA textural triangle attached to this examination paper and determine the textural class of the soil. (5 marks)
- What is the agronomic interpretation of the pH of this soil? (2.5 marks)
- Which group of microorganisms do you expect to be dominant in this soil? Give reasons to support your answer? (2.5 marks)
- How many kilograms of organic matter are present in one hectare of this soil layer? (5 marks)
- What is the C: N ratio of this soil? (2.5 marks)
- What is the Al saturation of this soil? (2.5 marks)
- What is the base saturation of this soil? (3 marks)
- How many 50 kg bags of agricultural lime with a neutralizing value of 94 % are required per hectare to reduce the Al saturation of the soil to 10 %? (5 marks)
- If a farmer wants to grow a potato crop that requires 175 kg N/ha, 35kg P/ha and 257 kg K/ha, would this soil be able to meet the N, P and K requirements of the crop, if only 4 % of the total N is mineralized in one season, and if all the available P and K can be taken up by the crop in one season? (12 marks).

5. A soil sample obtained from a field had a total mass of 160 g, an oven dry mass of 145 g, and a volume of 98 cm³ and particle density of 2.65g /cm³. Answer the following questions: (40 marks)
- What is the dry bulk density of the soil in kg/m³? (4 marks)
 - What is the volumetric moisture content of this soil in percent? (4 marks)
 - What is the porosity of the soil in percent? (4 marks)
 - How many litres of air are present in 10 m³ of this soil? (4 marks)
- e. If the volumetric moisture content of this soil at Field Capacity is 36.4 % and at Permanent wilting point is 7.3 %.
- Was the soil collected from the field moist or wet? Give reasons to support your answer. (4 marks)
 - What was the water holding capacity of this soil? (4 marks)
- f. If the soil horizon is 30 cm deep, and is at Field capacity, calculate the hydraulic head at the top and at the bottom of the soil horizon, assuming the top of the horizon is the reference level and indicate the direction of water flow between the top and the bottom of the soil horizon. (8 marks)
- g. A student decides to determine the saturated hydraulic conductivity of this soil, using 2 core rings 5 cm long and with an internal diameter of 5 cm, one to hold the water above the soil and the other to hold the soil sample. If after one hour she collects 90 mL of water in the beaker placed below the 5 cm long soil column, calculate the saturated hydraulic conductivity of the soil (k_{sat}) in m/s using Darcy's equation given below.

$$Q = k_{sat} * A * \frac{\Delta H}{L}$$

Show how you obtain ΔH , A, and Q. (8 marks)

Useful Data:

R = 8.3145 J/mol/k.

Temp k = temp °C + 273.15

Molar masses: K = 39g, P= 31g, N= 14 g, Ca= 40g, C=12g, O= 16 g, Mg=24g H= 1 g

SOIL SCIENCE IS FUN

END OF EXAMINATION

AGS 2110 FINAL EXAMINATION

COMPUTER NO:

TEXTURAL TRIANGLE FOR QUESTION 4a.

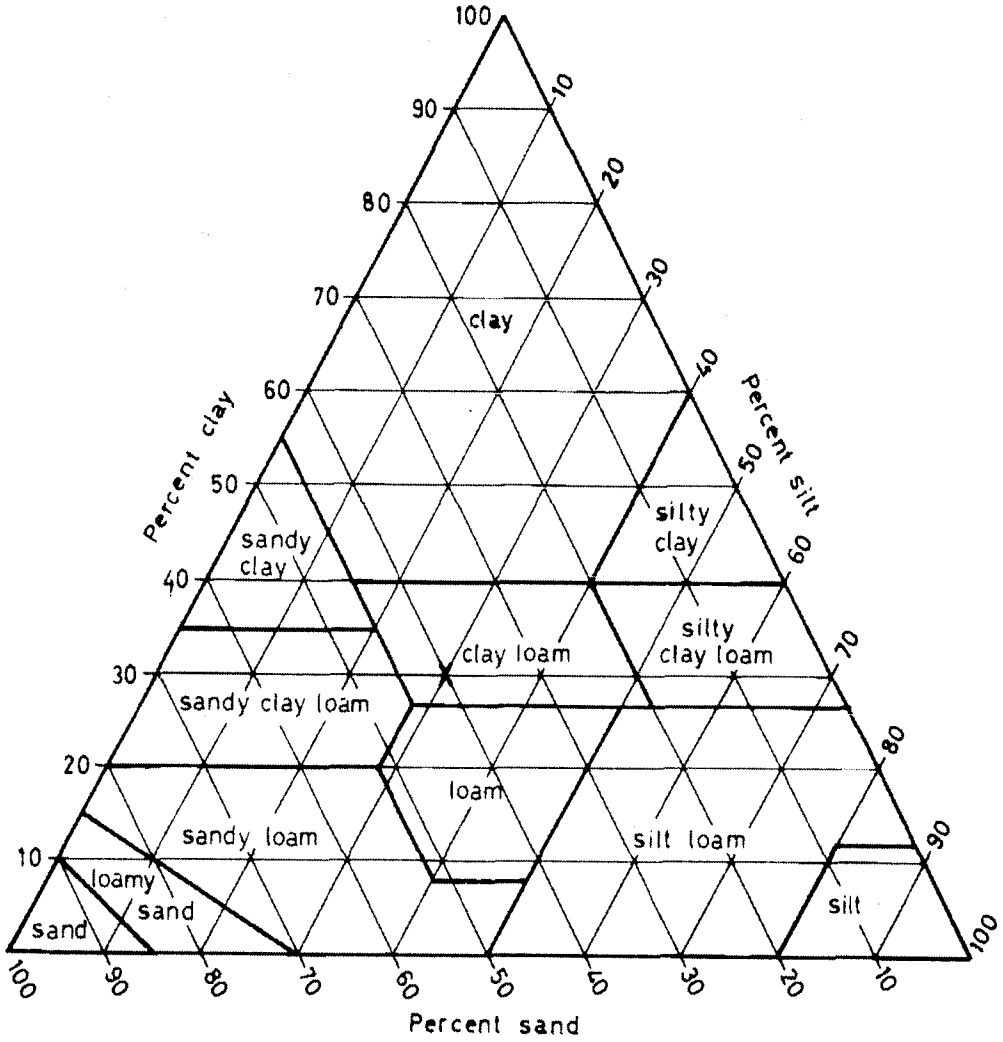



UNIVERSITY OF ZAMBIA

UNIVERSITY SUPPLEMENTARY EXAMINATIONS – FEBRUARY, 2022

AGS 3312: SOIL PHYSICS

Time: One and a half hours

Instructions: Answer **ALL** Questions

Total Marks: **100**

Non-programmable calculators are allowed

1. A given soil is in equilibrium with the water table at 60cm. **With the aid of a diagram**, and taking *the reference at the soil surface*, in intervals of 20 up to a depth of 80cm, determine; (Show your initial working) **[25 Marks]**
 - a. The potentials (gravitational (z), matric/pressure (h/p), total hydraulic head (H)) across the soil profile. **[20 Marks]**
 - b. Describe briefly the process of determining soil water content gravimetrically (include its pros and cons)? **[5 Marks]**

2. The soil is a three-phase system that governs specific characteristics and functions of a given soil. Briefly explain each of the following;
[15 Marks]
 - a. The importance of soil structure in plant growth **[5 Marks]**
 - b. Waterlogging **[2 Marks]**

c. Soil surface crusting [3 Marks]

d. The importance of organic matter in soil functions? [5 Marks]

The End



THE UNIVERSITY OF ZAMBIA
UNIVERSITY EXAMINATIONS – NOVEMBER 2022

AGS 3312
SOIL PHYSICS

TIME: 3 Hours

Marks: 100

INSTRUCTIONS: ANSWER ALL QUESTIONS AND WRITE LEGIBLY

1. Briefly define each of the following terms; *[20 marks]*
 - a) Hysteresis
 - b) Void ratio
 - c) Osmotic potential
 - d) Matric potential
 - e) Tensiometer

2. With a diagram illustration, list four points on the pF curve that are useful for soil water retention behavior *[15 marks]*

3. A given 100cm soil column in which soil water is in equilibrium with the water table at 50cm. Taking the reference at the water table, determine; *[20 marks]*
 - a) The potentials (gravitational (z), matric/pressure (h/p), total hydraulic head (H)) across the soil column at intervals of 10cm. [12 Marks]
 - b) What is the driving force for water to flow, and in which direction is the water flowing between the surface and 20cm in the profile? [2 Marks]
 - c) Draw the potential diagram of the soil column [3 Marks]
 - d) Is the soil water content the same throughout the soil column? Explain [3 Marks]

4. A soil 1.2m deep has a soil water content of 12% at a bulk density of 1500 kg/m³. *[20 marks]*
 - a) Calculate the depth of water in the soil profile (mm/m and in m³/ha) [6 Marks]
 - b) Calculate amount of water (in mm) that must be added to it to bring it to field capacity of 30%? [8 Marks]
 - c) State two indirect methods that can be employed to determine volumetric soil water content [4 Marks]
 - d) List two (2) disadvantages of using the Neutron Scattering method in monitoring soil moisture profiles. [2 Marks]

5. A soil in a greenhouse experiment has a wet bulk density of 1.7 g cm^{-3} and dry bulk density of 1.4 g cm^{-3} , calculate: *(25 marks)*
- a) Gravimetric moisture content (%) (5 marks)
 - b) Volumetric moisture content (%) (5 marks)
 - c) Depth of water (cm) in a 1m of this soil depth (5 marks)
 - d) Air-filled porosity (%) (5 marks)
 - e) New air-filled porosity (%) if a 2 cm of irrigation is applied and penetrates to a soil depth of 25 cm (5 marks)

END OF EXAMINATION



THE UNIVERSITY OF ZAMBIA
UNIVERSITY SUPPLEMENTARY EXAMINATIONS – FEBRUARY 2022

AGS 3711
AGROCLIMATOLOGY

Time: 2 Hours

Marks: **60**

Instructions: Answer **ALL** questions and write legibly

Non programmable calculators are allowed

1. Briefly discuss and give examples for each of the following. **[25 Marks]**
 - a. Greenhouse effect **[5 Marks]**
 - b. Agro-ecological zoning **[5 Marks]**
 - c. Climate change **[5 Marks]**
 - d. Climate change mitigation and adaptation **[10 Marks]**

2. Radiation depletion is one of the processes that occurs in the earth's atmosphere. **[15 Marks]**
 - a. What do you understand by radiation depletion? **[3 Marks]**
 - b. Briefly discuss processes of solar radiation depletion in the earth's atmosphere. **[9 Marks]**
 - c. Outline the importance of radiation depletion to life on earth. **[3 Marks]**

3. Meteorological measurements have a wide range of applications in diverse disciplines including agriculture. **[20 Marks]**
- a. What do you understand by meteorology? [2 Marks]
 - b. Give at least five applications of meteorology to agriculture. [5 Marks]
 - c. Briefly outline how measurements of at least five meteorological parameters are obtained at a standard meteorological station. [5 Marks]
 - d. Given an air temperature measurement of 27 °C and a relative humidity of 34 %, calculate the vapour pressure deficit. [6 Marks]
 - e. What do you understand by vapour pressure deficit? [2 Marks]
-

END OF EXAMINATION

UNIVERSITY OF ZAMBIA
SCHOOL OF AGRICULTURAL SCIENCES
FINAL EXAMINATION -NOVEMBER 2022
AGS 4210
SOIL MINERALOGY AND CHEMISTRY

INSTRUCTIONS:
questions

Answer All

TIME: 3 HOURS

Marks: 100

1. Soil reaction (pH) is the single most important determinant of bioavailability of nutrient ions for plant uptake such that its accurate determination is critical to making correct recommendations for soil amendments. Answer the following questions: **[10 marks]**
 - a. Elaborate on the meaning of the above statement. **[2 marks]**
 - b. Apply the Donnan ion exchange equation and explain the basis for measuring soil pH in a dilute solution of 0.01 M CaCl₂, especially for highly weathered tropical soils. **[5 marks]**
 - c. Describe how you can determine the polarity or nature of surface charge on colloids using measured pH values. **[3 marks]**

2. Chemistry deals with the study of the basic characteristics of substances and the different ways in which they react or combine with other substances. In Soil Chemistry the focus is the reactions of rocks and minerals, and organic substances with the soil solution. Answer the following questions: **[20 marks]**
 - a. Define the term rock. **[2 marks]**
 - b. List the EIGHT chemical classes of minerals and for any SEVEN of these, list ONE agronomically important mineral. **[7.5 marks]**
 - c. State the FIVE criteria essential to the definition of the term "*mineral*". **[5 marks]**
 - d. Is coal a mineral? Why and why not? **[2.5 marks]**
 - e. Both diamond and coal contain carbon. What makes one of these substances a mineral and the other one not? **[3 marks]**

3. In the dissolution of minerals in a closed system at a constant temperature and pressure, chemical equilibrium is the reversible condition that is established between the dissolving solid surface and the constituent components in the solution in the neighbourhood of the solid. Answer the following questions: [20 marks]

- a. Define and distinguish the terms “activity” and “concentration” of a chemical species. [2 marks].
- b. Using specific examples, distinguish a reaction that is at true *chemical equilibrium* from one that is said to be only in *steady state*. [3 marks]
- c. Ferrihydrite ($\text{Fe}(\text{OH})_3$) is a poorly crystalline sesquioxide found in soils. It controls the bioavailability of Fe^{3+} for plant uptake in soils. The release of Fe^{3+} from this mineral into solution is represented by the reaction below:

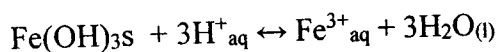

Given that the equilibrium constant for the above reaction is $10^{-37.5}$, explain why iron deficiency would be expected on crops grown in calcareous or over-limed soils with pH 8.5 compared to soils with pH 5.5. [7.5 marks]

- d. The dissolution of calcite in water is given by the reaction below:

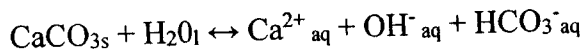

If the equilibrium constant for this reaction at 25°C and 1 bar pressure is $10^{-12.04}$, would you expect a soil solution containing 2.0 mM Ca^{2+} and 10.6 mM HCO_3^- to contain precipitated CaCO_3 (s) at pH 8.2 at the above temperature and pressure? Justify your answer with reasoning from chemistry. [7.5 marks]

4a. Define the following terms: [9 marks]

- i. Anhydrous mineral
- ii. Physical weathering
- iii. Secondary mineral
- iv. Plane of symmetry
- v. Low activity clays
- vi. Dioctahedral 2: 1 layer silicate

4b. Indicate whether the following minerals are true (T) or false (F). [6 marks]

- i. In the structure of the mineral $K(AlSi_3)O_8$, three elements occur as cations.
 - ii. Fe, Cu, Zn, and Si are among the eight most abundant elements in the earth's crust.
 - iii. Calcite contains more Ca than anorthite ($CaAl_2Si_2O_8$)
 - iv. A soil dominated by $FeOOH$ and $Al(OH)_3$ in its clay fraction is more highly weathered than a soil containing $CaSO_4 \cdot 2H_2O$ and $CaCO_3$ in its clay fraction.
 - v. Halite which is isometric has no birefringence and exhibits complete extinction in crossed polarized light.
 - vi. Incongruent weathering gives rise to the formation of secondary minerals in soils.
5. The physical properties of most minerals are related to the structure of the minerals.
Answer the following: [15 marks]

a. List the six structural groups of silicates minerals and sketch the arrangement of SiO_4^{4-} tetrahedra in two structural groups, and indicate the S: O ratio of the unit formulas of the two groups. [4 marks]

b. Fluorapatite ($Ca_5(PO_4)_3F$) is used in the manufacture of phosphate fertilizers:
Answer the following:

i. What is the percentage of phosphorus in pure fluorapatite? [2 marks]

ii. If the ionic radii of Ca^{2+} , P^{5+} and O^{2-} in fluorapatite are 0.106 nm, 0.035 nm and 0.140 nm respectively, how many O^{2-} ions surround each Ca^{2+} and P^{5+} ion in the mineral? Show necessary calculations to support your answer. [3 marks]

c. Fluorapatite belongs to the hexagonal system, and has the critical crystallographic properties: $a = 0.932$ nm, $c = 0.678$ nm, $n_e = 1.624$ and $n_o = 1.629$ Answer the following:

(i) Is fluorapatite isotropic or anisotropic? Give reasons to support your answer. [1.5 marks]

(ii) What would the retardation in nanometers (nm) of the slow ray from a ray of light with a wavelength of 440 nm passing through a 0.03 mm thin section. [2 marks]

- (iii) Would constructive or destructive interference occur after the right rays emerge from the mineral. 1 Show calculations to support your answer.
[2.5 marks]

6. Layer silicates are important primary and secondary minerals in soils. Some are important sources of nutrients, and major constituents of the clay fraction of soils. They have a significant influence on the physical and chemical behavior of soils. A layer silicate mineral with formula $(\text{Na}_{0.3} \text{Ca}_{0.05}) (\text{Al}_{1.8} \text{Mg}_{0.2}) (\text{Si}_{3.8} \text{Al}_{0.2}) \text{O}_{10} (\text{OH})_2$ commonly occurs in soils.

Answer the following: [20 marks]

- i. Is this a 1:1 or 2:1 layer silicate? Give reasons to support your answer. [2 marks]
- ii. To which group of layer silicates does this mineral belongs? Give reasons to support your answer. [2 marks]
- iii. Draw a schematic diagram of the structure of this mineral showing the various planes, sheets that make up the layers and interlayer space, in which the elements in the formula of the mineral occur? [4 marks]
- iv. Describe the properties of this mineral in terms of its sources of charge, the magnitude of the CEC, and Specific Surface Area, and its ability to expand and contract. Relate these properties to the crystal structure. [5 marks]
- v. Calculate the CEC of this mineral in $\text{cmol (+)}/\text{kg}$. [4 marks]
- vi. Write a balanced chemical weathering reaction of this mineral to kaolinite $(\text{Al}_2\text{Si}_2\text{O}_5 (\text{OH})_4$ by hydrolysis. [3 marks]

Useful data

Atomic masses: Ca=40g, Na=23g, Mg=24g, Si=28g, Al=27g, O=16, H=1g, S=32g, F= 19g P= 31g,

END OF EXAMINATION

UNIVERSITY OF ZAMBIA
SCHOOL OF AGRICULTURAL SCIENCES
AGS 4210
SOIL MINERALOGY AND CHEMISTRY
SUPPLEMENTARY EXAMINATION 2021

DURATION: 2 hours

MARKS: 100

INSTRUCTIONS: Answer all questions

1. Define the following terms: (10 marks)
 - a. Short range order mineral
 - b. Crystal form
 - c. Polymorphs
 - d. Variable charge
 - e. Sedimentary rock
 - f. Secondary mineral
 - g. Physical weathering

2. Indicate whether the following statements are true (T) or false (F): (15 marks)
 - a. Gibbsite can form from the weathering of Talc ($\text{Mg}_3\text{Si}_4\text{O}_{10}(\text{OH})_2$)
 - b. SiO_2 is a tectosilicate
 - c. Pure gypsum contains more Ca than pure calcite
 - d. Kaolinite is a trioctahedral 1:1 layer silicate
 - e. Thermal gravimetric analysis can be used for both qualitative and quantitative analysis of minerals
 - f. Carbonates minerals are more likely to be found in soils of Agro-ecological zone III than in Agro-ecological zone I of Zambia

3. Answer the following questions: (25 marks)
 - a. The main X-ray diffraction peaks for goethite are 4.18 Å, with a peak intensity of 100 %; 2.69 Å, with a peak intensity of 35 % and 2.45 Å, with a peak intensity of 50 %. Sketch a diffractogram showing the 2θ value at which the three peaks occur and indicating relative the intensities of each peak, assuming that goethite was analyzed using $\text{CuK}\alpha$ radiation, with $\lambda = 1.5418 \text{ \AA}$. Show how you obtain the 2θ values corresponding to each of the peaks. (7.5 marks)

 - b. Write a balance chemical reaction for the weathering of muscovite ($\text{KAl}_2(\text{AlSi}_3)\text{O}_{10}(\text{OH})_2$) to kaolinite ($\text{Al}_2\text{Si}_2\text{O}_5(\text{OH})_4$) by hydrolysis (4 marks)

- c. In 1982 a hydrated sodium magnesium sulphate mineral ($\text{Na}_2\text{Mg}(\text{SO}_4)_2 \cdot 5\text{H}_2\text{O}$) was discovered in soils from Konya desert in Turkey which they named Konyaite. The crystallographic properties of Konyaite are:

$$a = 5.784 \text{ \AA}, b = 24.026 \text{ \AA}, c = 8.066 \text{ \AA}; \alpha = 90^\circ, \beta = 95.37^\circ, \gamma = 90^\circ$$

(i) To which crystal system does Konyaite belong? Give reasons to support your answer. (4 marks)

(ii) What is the axial ratio of Konyaite? (2 marks)

- d. Thernadite (Na_2SO_4) is a common sulphate mineral that occurs in surface salts crusts in soils of some Sugarcane fields at Nakambala Sugar Estates in Mazabuka. Using the thermodynamic data below calculate the solubility (moles/L) of thernadite in water at 25 °C. (5 marks)

Species	ΔG_f° (J.mol ⁻¹)
$\text{Na}_2\text{SO}_4\text{s}$	-1269,985
Na^+_{aq}	-261,900
$\text{SO}_4^{2-}_{\text{aq}}$	-744,630

- e. Would you expect to find thernadite in very wet soils? Give reasons to support your answer. (2.5 marks)
4. Soil chemical reactions are basically an electrostatic interaction between surface charge on colloids and ions in solution, involving attraction, repulsion, exchange, transfers of electrons, etc. between these two phases. Answer the following questions: (25 marks)
- a. Describe how you would demonstrate that soil colloids are predominantly negatively charged. (5 marks)
- b. State the major differences between Cation Exchange Capacity determined using ammonium acetate buffered at pH 7 (CEC- pH 7) and the Effective Cation Exchange Capacity (ECEC). (4 marks)
- c. Briefly describe how the CEC-pH 7 and ECEC are determined on soil samples in the laboratory. (6 marks)
- d. Express the potassium content of a soil layer with a depth of 20 cm, a bulk density of 1300 kg. m⁻³ and a test value of 0.22 cmol (+) K. kg⁻¹, in kg of K₂O per hectare. (10 marks)

5. To a very large extent minerals present in soils (solid phase of soil) control the amounts of soluble ions in the soil solution. Answer the following questions: (25 marks)
- State FIVE fundamental characteristics of substances that are called minerals. (5 marks)
 - Explain why expressing dissolved ionic species as *activities* rather than *concentrations* is much more useful for application to describing the chemical composition of soil systems. (5 marks)
 - Describe how you can use the *Solubility Product Principle* to determine whether a soil mineral would dissolve or precipitate in water. (5 marks)
 - Elaborate on the concept of salt balance as a tool to manage salt-affected soils. (10 marks)

Useful Data:

$$R = 8.3415 \text{ J}\cdot\text{mol}^{-1}\cdot\text{K}^{-1}$$

$$\text{Temp (K)} = \text{Temp (}^{\circ}\text{C)} + 273.15$$

Molar masses: Ca= 40g, Na=23g, S= 32g, O=16g, K=39g, C=12g, H= 1g

END OF EXAMINATION



THE UNIVERSITY OF ZAMBIA
UNIVERSITY EXAMINATIONS – NOVEMBER 2022
AGS 4232 - SOIL FERTILITY AND AMENDMENTS

TIME: 3 hours

Marks: 100

INSTRUCTIONS: ANSWER ALL QUESTIONS AND WRITE LEGIBLY

1. State whether the following statements are **true (T)** or **false (F)**. [10.5 marks]
- Only two of the secondary plant nutrients are taken up by plants in anionic form.
 - Crop rotation is having two or more crops on the same field at the same time of the growing season.
 - A fertilizer with a grade of 34:0:0, N:P:K, is termed as a straight fertilizer.
 - Adding adequate organic materials to the soil will improve the soil texture.
 - The nutrient ratio of a fertilizer indicates the minimum guaranteed nutrient content of a fertilizer.
 - In the sufficient stage of the crop response curve, increasing nutrient supply results to no change in yield.
 - Temperature is one of the five soil forming factors.
2. a. Answer the following question: [12.5 marks]
- Briefly describe the classification of the plant nutrients according to plant nutrition. [4 marks]
 - List all the plant nutrients that are classified as primary nutrients according to the fertilizer industry and indicate their bioavailable forms. [4 marks]
 - What is the major driving force behind the movement of nutrients in the soil by mass flow? [1.5 marks]
 - Briefly explain your understanding of the term soil fertility. [3 marks]
- b. A soil from a smallholder farmer's field was tested and had the characteristics shown in Table 1.

Table 1. Soil characteristics

Depth (cm)	Bulk density (g/cm ³)	pH (0.01M CaCl ₂)	Available P (mg/kg soil)	Total N (%)	SOM (%)	K Na Ca		
						(cmol/kg soil)		
20	1.3	5.10	39.8	0.13	1.6	0.23	0.15	1.17

If the farmer would like to grow Green Pepper which has the nutrient requirement as follows:

N: 150 kg/ha

P: 30 kg/ha

K: 70 kg/ha

Using the data provided in Table 1, answer the following questions: **[15 marks]**

- i. Would this soil be able to supply adequate amounts of K and P to meet the requirement for growing Green Pepper? Show your working to support your answer. **[5 marks]**
 - ii. If all the N required by the crop is supplied using Urea (46% N), while the shortfall of P, is supplied Triple Super Phosphate (46% P₂O₅), and the shortfall of K in the soil, is supplied by Muriate of Potash (60% K₂O), calculate the number of 50 kg bags of Urea, Triple Super Phosphate and Muriate of Potash required to produce Green Pepper on this one hectare plot? **[3 marks]**
 - iii. Calculate the potential N supply of this soil layer in kilograms per hectare. **[3 marks]**
 - iv. Describe four (4) agronomic strategies that farmers can use to ensure high fertilizer use efficiency. **[4 marks]**
3. Soil acidity can be caused by natural and human-induced factors. **[12 marks]**
- a. Briefly discuss any two (2) natural causes of soil acidification. **[4 marks]**
 - b. Using balanced chemical equations, show how the process of nitrification of ammonium fertilizers can lead to acidification of the soil **[4 marks]**
 - c. What are the advantages of using dolomitic agricultural lime to ameliorate soil acidity in comparison with calcitic agricultural lime? **[2 marks]**
 - d. Briefly discuss why gypsum (CaSO₄·2H₂O) cannot be used to neutralize soil acidity. **[2 marks]**

4. A soil sample was analysed for selected chemical properties and the results are tabulated below. Answer the following questions: **[20 marks]**

pH	Organic matter	K ⁺	Na ⁺	Ca ²⁺	Mg ²⁺	Exc. Acidity (1M KCl)	ECEC
0.01 M CaCl ₂	(%)	Ammonium Acetate (cmol(+)/kg)					
4.28	1.92	0.19	0.02	1.47	0.68	0.76	3.12

- a. Briefly explain the expected chemical behaviour of phosphorus at the given pH of the soil. **[2 marks]**

- b. Calculate the lime requirement of this soil if the target is to neutralize exchangeable acidity using pure calcite (CaCO_3). Assume an area of one hectare, soil depth of 20 cm and bulk density of 1400 kg/m^3 . [6 marks]
- c. Given that you are presented with two liming materials with neutralizing values (NVs) and particle size distributions per 100 g sample as tabulated below, calculate the amount of lime to be applied to the same soil described in (b) above. [8 marks]

Sieve size	Sample A (NV = 88 %)	Sample B (NV = 178 %)
Coarser than 8 mesh	0 g	2 g
8 to 40 mesh	3 g	8 g
40 to 60 mesh	18 g	28 g
Finer than 60 mesh	79 g	62 g

- d. Assuming that the prices per 50 kg of **Sample A** and **Sample B** are K 58 and K 70, respectively, which of the two samples would you consider to be cheaper based on the lime requirements calculated in (c) above? [4 marks]

5. Answer the following questions. [30 marks]

- a. In what geographical locations/agro-ecological region can you expect to find salt-affected soils in Zambia and explain the circumstances under which they might form? [4 marks]
- b. Describe the soil properties that would indicate to you that the soils are salt-affected. [4 marks]
- c. Describe the appropriate soil management practices to ameliorate sodic soils as distinguished from those of managing merely saline soils. [6 marks]
- d. Determine the amount of agricultural lime (NV of 85 %) in kilogram per hectare that you would recommend for an acid soil with the following soil test analysis: Al 0.8, Ca 0.6, Mg 0.3, K 0.15, Na 0.1 and H 0.2 cmol (+) kg^{-1} and on which it is proposed to grow soybeans which has a Critical Aluminum Saturation (CAS) or Target Aluminum Saturation (TAS) of 20 %. Assume a soil depth of 20 cm and bulk density of 1400 kg/m^3 . [8 marks]
- e. If a soil has a CEC of $2.3 \text{ cmol (+) kg}^{-1}$, pH of 4.5 and a base saturation of 30% and you need to lime the soil to a pH of 5.5 with a base saturation of 50%. Calculate the amount of agricultural lime (NV of 80 %) in kg/ha , required to raise the pH from 4.5 to 5.5. Assume a soil depth of 20 cm and bulk density of 1300 kg/m^3 [8 marks].

Atomic masses: O = 16g, Na = 23g, S = 32g, N = 14g, P = 31g, Al = 27g, H = 1g, K = 39g, C=12g, Mg=24g, Ca=40g

END OF EXAMINATION

THE UNIVERSITY OF ZAMBIA

UNIVERSITY SUPPLEMENTARY EXAMINATIONS 2020/21 ACADEMIC YEAR

AGS 4232

SOIL FERTILITY AND AMENDMENTS

TIME: 2 HOURS

MARKS: 100

INSTRUCTIONS:

ANSWER ALL QUESTIONS

Useful molar masses: N=14g; P=31g; K=39g; Ca=40g; Mg=24g; Al=27g; Na=23g; O=16g

1. State whether the following statements are true (T) or false (F): [15 marks]
 - a. The law of the minimum in plant nutrition states that the yield of a crop can only be as high as permitted by the factor that is not limiting.
 - b. Nitrogen immobilization is the conversion of inorganic nitrogen to organic nitrogen.
 - c. The negative charge on humus in soils is a result of isomorphous substitution.
 - d. A soil with a total pore space of 50% has a higher bulk density than a soil with a total pore space of 46% if both soils have a particle density of 2.65 g/cm³.
 - e. Plant nutrients that are classified as macronutrients are more abundant in the soil than those classified as micronutrients.
 - f. Fertigation is applying fertilizer through irrigation water.
 - g. One of the major limitations to crop production for soils in Agro-ecological region III of Zambia is strong acidity.
 - h. Three (3) of the six (6) macronutrients are classified as primary nutrients by the fertilizer industry.
 - i. Hydrolysis is a physical weathering process involving the addition of hydrogen to mineral structure.
 - j. Crop rotation is having two or more crops in the same field at the same time of the growing season.
2. A material that a farmer wants to use as organic fertilizer has the properties indicated in Table 1.

Table 1. Selected chemical properties of organic material

Organic carbon	N	P	K	S
%				
23.2	1.5	1.3	2.9	0.8

Answer the following questions: [25 marks]

- a. Define nitrogen mineralization and nitrogen immobilization. [2 marks]
- b. Can this material be a good source of plant nutrients nitrogen and phosphorus if applied as an organic fertilizer? Give reasons to support your answer. [3 marks]
- c. How much of the material should be added to a one hectare field to supply an equivalent of 100 kg nitrogen? [5 marks]
- d. How many kilograms of potassium would be contained in the amount of organic matter required to supply an equivalent of 100 kg N? [5 marks]

- e. Organic matter is key to productivity of soils because it positively affects both physical and chemical properties of the soil. List any five (5) properties of organic matter and indicate their associated effects on soils. [10 marks]
3. Soil acidity is a recurrent problem in most tropical environments with excessive rainfall. Therefore, farmers, need to lime their cropped fields. Answer the following questions. [30 marks]
- Briefly discuss any three (3) causes of soil acidity. [6 marks]
 - Briefly discuss the relationship between soil acidity and nutrient availability for crop uptake.[7 marks]
 - Briefly describe how you would determine the lime requirement of a soil with an initial pH of 5.00 assuming that the desired soil pH is 6.5 and that you are provided with a liming material that is in powdered form. [12 marks]
 - Using balanced chemical equations show how the process of nitrification of ammonium fertilizers can lead to acidification of the soil. [5 marks]
4. A farmer had a sample of soil from their farm analysed for various soil fertility parameters whose results are shown in Table 2.

Table 2. Soil analysis results

pH in CaCl ₂	Organic Matter	Total N	Avail. P	K	Na	Ca	Mg	Exch. acidity	S
	%	%	mg kg ⁻¹	cmol kg ⁻¹					mg kg ⁻¹
4.38	0.64	0.12	3.79	0.25	0.10	1.96	1.02	1.32	7.0
Micronutrients									
Cu	Fe	Mn	Zn						
mg kg ⁻¹									
0.64	19.4	4.26	0.54						

Answer the following questions: [30 marks]

- What is the agronomic interpretation of the soil pH? [3 marks]
- Identify any THREE (3) constraints to soil productivity in this soil. [3 marks]
- For the three constraints identified above give a specific recommendation on what the farmer should do to remedy the constraints. [12 marks]
- Describe the mechanism of nutrient and pH buffering in soil. [3 marks]
- Indicate the soil properties or factors that have an influence on the buffering capacity of the soil, and explain how they influence buffering capacity. [4 marks]
- List and discuss factors that affect the quality of agricultural lime. [5 marks]

END OF EXAMINATION



THE UNIVERSITY OF ZAMBIA
UNIVERSITY EXAMINATIONS - JUNE 2022
AGS 5511
AGRICULTURE HYDRAULICS AND IRRIGATION

Time: Three (3) Hours

Total Marks: 100

Instruction: Answer all Questions

1. Briefly define each of the following terms and state their significance for fluid flow problems **(25 marks)**
 - a) Hydrostatics
 - b) Laminar flow
 - c) Darcy-Weisbach formular
 - d) Aquiclude
 - e) Air-lift pump

2. Turbulent flow is characterized by random, irregular, and haphazard movement of fluid particles, list the one (1) major and six (6) minor energy losses attributed to turbulent flow in pipes **(15 marks)**

3. A farmer's field has a trapezoidal channel with side slopes of 1.5 horizontal to 1 vertical and bed slope of 1 in 1800. If the channel is to carry water at $30 \text{ m}^3/\text{s}$ and Chezy's constant is 50, determine the optimum dimensions of the channel i.e., bed width (b) and depth of flow (y). **(15 marks)**

4. A horizontal pipe 150 mm in diameter is joined by sudden enlargement to 225 mm diameter pipe. Water is flowing through it at a rate of $0.05 \text{ m}^3/\text{s}$. Find: **(20 marks)**
 - a) Loss of head due to abrupt expansion
 - b) Pressure difference in the two pipes, and
 - c) Change in pressure if the change of section is gradual without any loss

5. A farmer at Nanga has a rectangular channel of 0.5 m width that supply water to an irrigated field. A hydraulic jump occurs at a point where depth of water flow is 0.15 m and Froude number is 2.5. Determine: **(25 marks)**
 - a) Upstream velocity (m/s)
 - b) Discharge per unit width (m^3/s per m)
 - c) Specific energy (m)
 - d) Critical depth (m)
 - e) Downstream depth (m)

End of Exam



THE UNIVERSITY OF ZAMBIA

AGS 5522

MANAGEMENT OF IRRIGATION AND DRAINAGE SYSTEMS FINAL EXAMINATION NOVEMBER 2022

TIME: 3 Hours 00 Minutes

Marks: 100

INSTRUCTIONS: ANSWER ALL QUESTIONS AND WRITE LEGIBLY

Q1. a) How would soil textural class influence your design of a sprinkler irrigation system, give examples for your answer?

[5 Marks]

b) You are given the following information on soil and crop data: Field to be irrigated is 10 ha, Soil is medium texture, loam with total available soil moisture (TAM) equal to 190 mm/m, peak crop consumptive use for the wheat crop equal to 5.8 mm/day, allowable soil moisture (p) is 50 %, effective root zone depth (RZD) is 70 cm. Determine the net depth (I_{net}) of water application

[5 Marks]

c) Determine the irrigation frequency (IF)? What will be the final adjustment to the design parameters?

[10 Marks]

Q2. A surface irrigation event involves four phases, list and explain what these phases involve

[20 Marks]

Q3. Explain how soil criteria may influence your choice of a surface irrigation system. Give examples where necessary [20 Marks]

Q4. Discuss the five key data requirements for the successful design of a sprinkler irrigation system

[20 Marks]

Q5. a). Discuss the factors that you would use to assess the performance of a surface irrigation system [10 Marks]

b) With the aid of a sketch, explain the different components of infiltrated water under a surface irrigation system [10 Marks]

END OF EXAMINATION

4. In a survey in Kafue District to promote conservation farming, the sample size was estimated at 1000 smallholder farmers, given that the $p=0.05$, $e =0.05$, $z=1.96$. answer the following questions
- Calculate, what could be the population of smallholder farmers in Kafue District? **[6 Marks]**
 - Why is it important to choose the appropriate sample size? **[4 Marks]**
 - What is the strength of qualitative survey compared to quantitative survey **[4 Marks]**
5. Fifty four (54) bags of Uniturtle lime with an effective neutralizing value of 85.5% were recommended for liming a certain farm in Lusaka West. Given that the depth of soil sampling was 20cm and a bulk density of 1500kg/m³. Answer the following questions;
- Estimate the exchangeable aluminium of the soil? **[5 Marks]**
 - Given that the CEC of the soil is 2.2 cmol (+)/kg soil, estimate the aluminium saturation percent? **[2 Marks]**
 - What is the importance of the aluminum saturation percent? **[3 Marks]**
6. The valleys in Zambia, experiences the hottest temperatures in the country.
- Explain why the growing period is shorter in the valleys? **[3 Marks]**
 - Explain the effects of climate change are dominant in such areas? **[3 Marks]**
 - The evapotranspiration is very high in the valleys implying frequent irrigation interval, suggest at 4 other measures which can be used in water management to increase productivity? **[4 Marks]**
7. A sunflower project to process cooking oil has set up a 200 ha farm in Lukanga swamps. Given that the land is susceptible to waterlogging, answer the following questions?

- i. The method would you use to ascertain the size of the land for planning purposes before you go to the project size? **[2 Marks]**
 - ii. How would you differentiate floods from waterlogging? **[2 Marks]**
 - iii. If you find that the sunflower is unsuitable because of low rainfall, what advice would you suggest to the project? **[4 Marks]**
 - iv. Given that the field capacity, soil critical moisture content and permanent wilting point of sunflower are 0.65, 0.4 and 0.25. Calculate the readily soil moisture available to sustain the crop growth. **[2 Marks]**
8. The rapid increase in population has exacerbated the demand for food and fuel worldwide exerting more pressure on land availability for agriculture thus causing use of mountainous lands which is prone to erosion. This land being proposed for crop production and house settlement has a length dimension of 500m with an erodibility of 0.3, the rainfall erosivity is 200, slope of 13% and assuming a bulk density 1.5ton/m³: (Refer to Figure 1 attached)
- a. Given that they are no crop management and erosion control processes being practiced, calculate the soil loss in tons/ha/year **[2 marks]**
 - b. Based on your answer in (a),
 - a. calculate the depth of soil removed in cm by erosion per annum? **[2 marks]**
 - b. calculate the depth of soil removed in cm in a decade? **[1marks]**
 - c. Given that the all area would be planted with velvet velvet bean with a crop management practice of 0.2 and that the erosion control practice is 0.5, calculate the soil loss tons/ha/year? **[3 marks]**
 - d. Given that the all area would be planted with maize which has a crop management practice of 0.5 and that the erosion control practice is 0.5, calculate the soil loss in tons/ha/year? **[3 marks]**

- e. Based on c and d which option would reduce soil erosion significantly? **[1 marks]**
- f. Given that soil losses of 17 t/ha/year causes crop loss of 8% annually, state which crop will result in significant losses, given that velvet beans and maize give that the actual yield are 3 and 5 t/ha. **[5 marks]**
- g. With the aid of a drawing, design 100 m terraces and calculate the soil that need to moved, given that the new slope is 8% and that $1\text{m}^3=1.5\text{ton}$. **[7 marks]**
- h. What are the advantages and disadvantages of terracing **[2 marks]**
- i. Why is terracing applied as the last option in controlling soil erosion **[3 marks]**

Formulas

$$n = N \times \frac{\frac{Z^2 \times p \times (1 - p)}{e^2}}{\left[N - 1 + \frac{Z^2 \times p \times (1 - p)}{e^2} \right]}$$

Lime Requirement = 2 * Exchangeable Aluminium

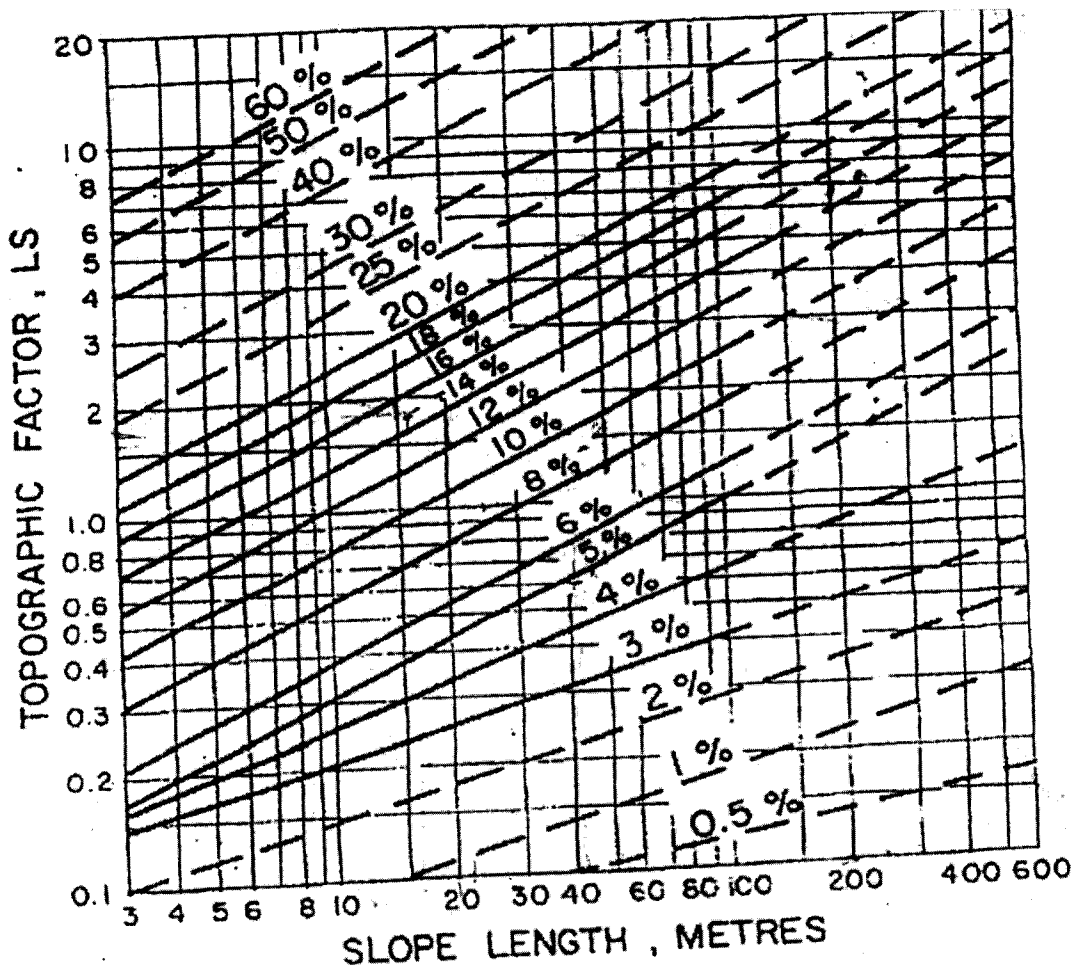

Figure 1: Relation between topographic factors LS and slope length