

THE UNIVERSITY OF ZAMBIA
FIRST SEMESTER EXAMINATION
SCHOOL OF ENGINEERING

MARCH 1988

1.	STATICS AND INTRODUCTION TO STRENGTH OF MATERIALS.....	CE 219
2.	STRENGTH OF MATERIALS.....	CE 311
3.	SOIL SCIENCE, ROADS AND HYDRAULICS.....	CE 365
4.	FLUID MECHANICS.....	CE 389
5.	STRUCTURAL ENGINEERING.....	CE 431
6.	HYDROLOGY.....	CE 565
7.	WATER MANAGEMENT AND HYDRAULIC STRUCTURES.....	CE 585
8.	FARM MACHINERY AND POWER.....	EA 311
9.	FARM STRUCTURES I.....	EA 521
10.	PRINCIPLES OF ELECTRICITY.....	EE 209
11.	PRINCIPLES OF ELECTRICITY II.....	EE 309
12.	ELECTRIC CIRCUITS.....	EE 311
13.	ELECTROMECHANICS AND ELECTRICAL MACHINES.....	EE 321
14.	DIGITAL ELECTONICS.....	EE 381
15.	ELECTROMAGNETIC FIELDS.....	EE 411
16.	TELECOMMUNICATION I.....	EE 471
17.	COMPUTER ENGINEERING.....	EE 481
18.	ELECTRONIC ENGINEERING.....	EE 541
19.	INTRODUCTION TO COMPUTING.....	EG 279
20.	ENGINEERING, MANAGEMENT, AND SOCIETY II.....	EG 575
21.	ENGINEERING MECHANICS ^{MATHEMATICS}	EM 311
22.	ENGINEERING MECHANICS ^{MATHEMATICS}	EM 411
23.	THERMODYNAMICS I.....	ME 341
24.	PRODUCTION TECHNOLOGY I.....	ME 415
25.	STRENGTH OF MATERIALS II.....	ME 431
26.	FLUID MECHANICS 2.....	ME 461
27.	HEAT TRANSFER.....	ME 541
28.	VIBRATIONS AND CONTROL ENGINEERING.....	ME 571
29.	CARTOGRAPHY I.....	SE 321
30.	PHOTOGRAMMETRY I.....	SE 332
31.	METHODS AND PRINCIPLES OF SURVEYING I.....	SE 371
32.	SURVEYING MATHEMATICS.....	SE 411
33.	CARTOGRAPHY II.....	SE 422
34.	PHOTOGRAMMETRY II.....	SE 431
35.	REMOTE SENSING.....	SE 462
36.	SE 481
37.	GEOLOGY MAPPING.....	SE 481
38.	PHOTOGRAMMETRY III.....	SE 531
39.	GEODESY II.....	SE 542
40.	GEOGRAPHIC INFORMATION SYSTEMS.....	SE 561
41.	ENGINEERING MATERIALS I.....	ME 252

THE UNIVERSITY OF ZAMBIA.

UNIVERSITY FIRST SEMESTER EXAMINATIONS - MARCH 1998.

CE 219

STATICS AND INTRODUCTION TO STRENGTH OF MATERIALS.

TIME: Three Hours.

ANSWER: Any THREE from Section A, and Any TWO from Section B.

SECTION - A.

1. The uniform rectangular block rests on its corner edge A and is supported by the horizontal tension T in the chord attached to the diagonally opposite corner. If the horizontal component of the contact force at A cannot exceed 20 % of the vertical component of this force before slipping occurs, calculate the minimum value of θ that can be maintained for equilibrium as the chord is gradually relaxed but still kept horizontal. (Fig: 1)
2. Calculate all member forces and components of the reactions at supports A and B acting on the truss shown in Fig: 2.
3. The threaded collar in Fig: 3 is used to connect two shafts, both with right hand threads on their ends. The shafts are under a tension $T = 8$ kN. If the threads have a mean diameter of 16 mm and a lead of 4 mm, calculate the torque M required to turn the collar in either direction with the shafts prevented from turning. The coefficient of friction is 0.24.
4. The maximum and minimum moments of inertia of the shaded area in Fig: 4 are 15 m⁴ and 5 m⁴, respectively, about axes passing through the centroid G, and the product of inertia with respect to the X-Y axes is $-5\sqrt{3}/2$ m⁴. Calculate I_x and the angle α measured from the X-axis to the axis of maximum moment of inertia.

SECTION - B.

5. The bar AD in Fig: 5 is pinned at A. It is supported at B by a copper rod of 40 mm² in area and 1.5 m in length, and also at C by a steel rod of 30 mm² in area and 1 m long. The bar AD is rigid and horizontal in position before a load of 10 kN is applied at D. Determine the stresses and elongations produced in the copper and steel rods after application of this load. Given, $E_c = 100$ kN/mm² and $E_s = 200$ kN/mm².

6. A composite bar shown in Fig: 6 is made up of aluminium and steel and is held between two end supports. The bars are stress-free at a temperature of 38°C . What will be the stresses in the two parts of the bar if the temperature is 21°C , when:-

- (a) the supports are unyielding, and when
- (b) the supports can come nearer to each other by 0.1 mm ?

Given, $E_s = 210\text{ kN/mm}^2$ and $E_a = 74\text{ kN/mm}^2$
 $\alpha_s = 11.7 \times 10^{-6}/^{\circ}\text{C}$ and $\alpha_a = 23.4 \times 10^{-6}/^{\circ}\text{C}$

7. A piece of material is subjected to two tensile stresses at right angles and a shearing stress acting upwards on the right hand face (Fig: 7). Their respective values are 100 , 200 and 200 N/mm^2 . Determine the direction and magnitude of the principal stresses in the material. Also locate the planes of maximum shearing stresses and calculate the normal and shearing stresses on these planes. Show these stresses on a properly oriented element.

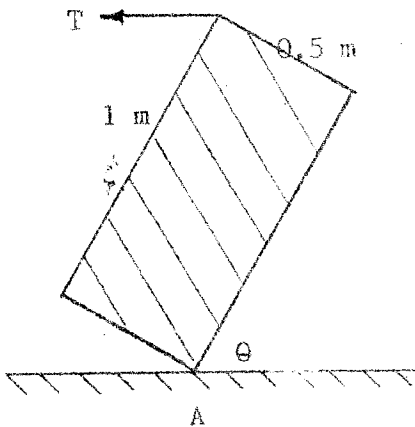

FIG: 1.

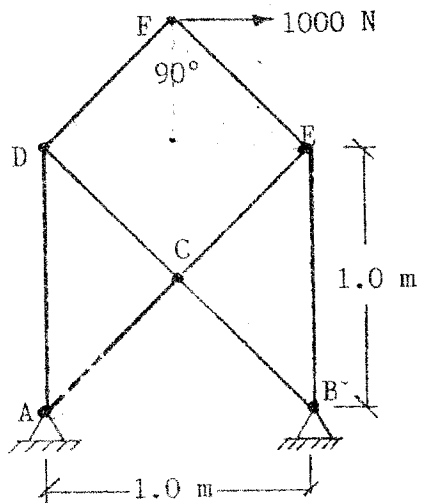

FIG: 2.

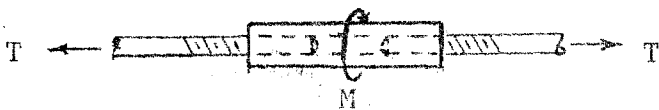

FIG: 3.

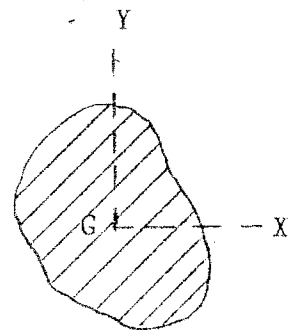
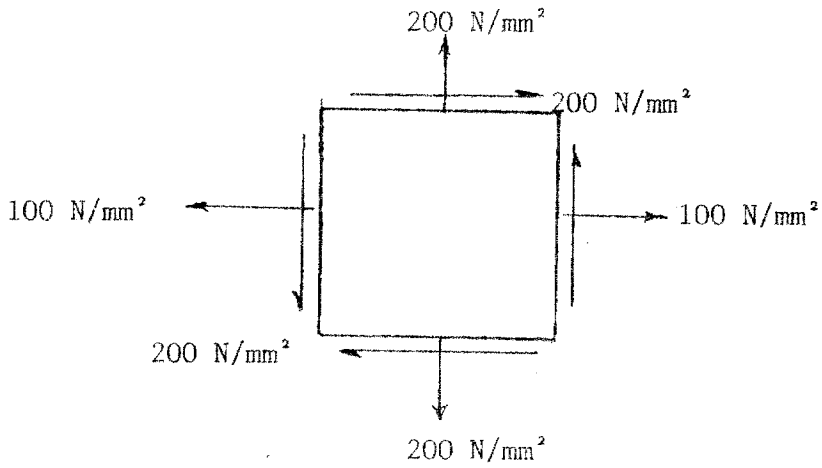
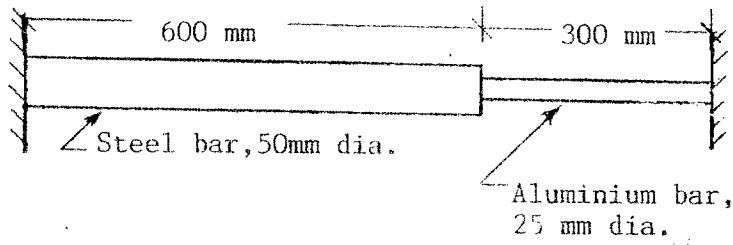
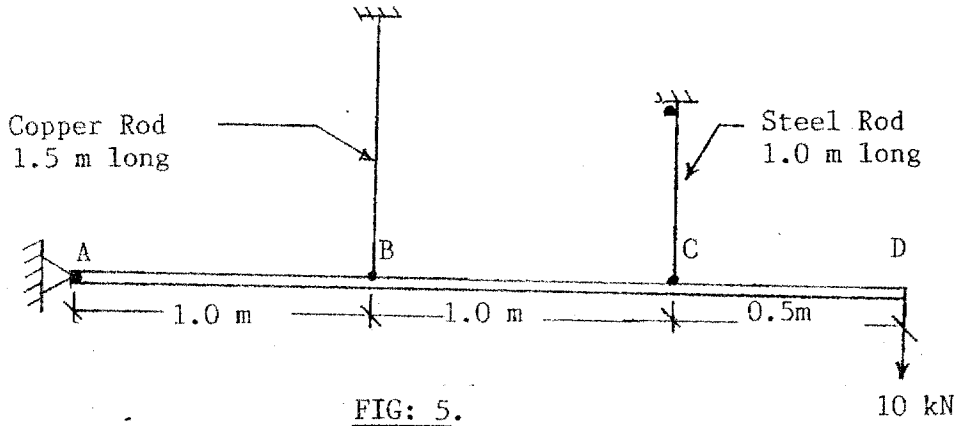

FIG: 4



END OF EXAMINATION

THE UNIVERSITY OF ZAMBIA
UNIVERSITY EXAMINATIONS- 1st SEMESTER 1996/98
CE311
STRENGTH OF MATERIALS

TIME: THREE HOURS

INSTRUCTIONS TO CANDIDATE

- (a) Candidates must ensure that their computer numbers are clearly written on each answer booklet used and that the number of questions answered are entered in the space provided on the front cover of the answer booklet.
- (b) Answer FIVE questions only.
- (c) All questions carry equal marks (20). Marks of sub-questions are indicated at the end of each sub-question.
- (d) Mathematical gadgets and drawing instruments are allowed.

MAXIMUM SUM OF MARKS: 100

CLOSED BOOK

- Q1 (a) Over what span can a uniform distributed load of 6.3 kN/m run be carried if the maximum bending stress is 100 N/mm² for the T-section beam shown in figure one. (08)
- (b) What additional concentrated load that can be carried at mid span if the maximum allowed bending stress is 175 N/mm². (08)
- (c) What is the major advantage of I- and T- sections over rectangular sections for beams? What advantage does the T section sometimes have over the I-section? (04)
- Q2 Determine the location and magnitude of maximum deflection for the beam shown in figure 2. $E = 200 \text{ GPa}$, $I = 30 \times 10^{-6} \text{ mm}^4$.
- Q3 Prove that a strut that is fixed supported on both ends (built in) will support four times the compression force that the same strut over the same length would if the ends were pin supported. (20)
- Q4 (a) Find the end moments and the middle span moment for a built in beam carrying a uniformly distributed load over the entire span. Comparing with the load carried by a simply supported beam, how many times more can be carried in a built in beam. (10)
- (b) If the built in beam in (a) is to be loaded until plastic failure, what will be the load factor if load factor is the ratio of load at collapse to load at yield point. (10)
- Q5 A 50 mm by 12.5 mm flat steel bar was placed in a testing machine and subjected to 60 kN load acting as shown in figure 3. An extensometer placed in the line with the load recorded an extension of 0.16 mm on a gauge length of 200 mm. Calculate;

(a) The maximum and minimum stresses set up (in tension and compression if present)(10)

(b) The Young's Modulus. (10)

Q6 For the cantilever beam shown in figure 4, using the **Moment Area method**; determine;

(a) the vertical deflection at **B** in millimetres; (10)

(b) the vertical deflection at **C** in millimetres; (5)

(c) the rotation at **C** in radians. (5)

For the beam, $E = 200 \times 10^9 \text{ N/m}^2$ and $I = 40 \times 10^6 \text{ mm}^4$.

Q7 Two rectangular bars, one steel and one brass, each 40 mm by 10 mm are placed together to form a beam 40 mm wide and 20 mm deep, on two supports 750 mm apart, the brass on top of the steel. Determine the maximum central load if the bars are:

(a) separate and can bend independently (8)

(b) firmly secured throughout their length.(8)

(c) Sketch the stress and strain variations at the mid span for the two cases.(4)

Maximum allowable stress in the brass = 70 N/mm². Maximum allowable stress in the steel = 105 N/mm²; $E_b = 87\,500 \text{ N/mm}^2$; $E_s = 210\,000 \text{ N/mm}^2$.

Q8 A T-section beam has a width of 125 mm and a depth of 150 mm. The flanges and the web are 10 mm thick. Calculate the maximum torque that can be applied to this beam if the yield strength is 235 N/mm². Assume a factor of safety of 1.5. (20)

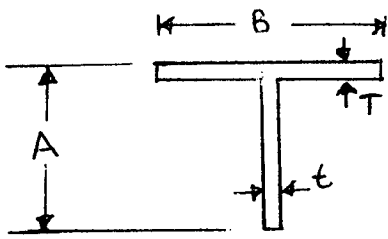

$B = 209 \text{ mm}$
 $A = 110 \text{ mm}$
 $T = 20 \text{ mm}$
 $t = 13 \text{ mm}$

Figure 1

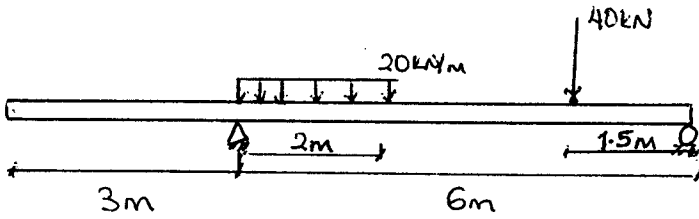

Figure 2.

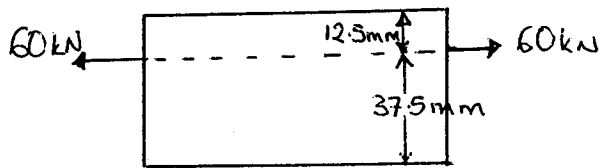

Figure 3

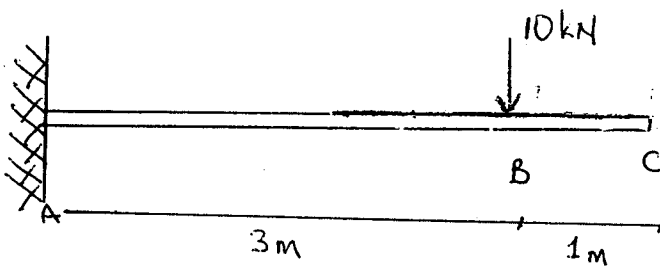

Figure 4

THE UNIVERSITY OF ZAMBIA

UNIVERSITY FIRST SEMESTER EXAMINATIONS - MARCH 1998

CE 365

SOIL SCIENCE, ROADS AND HYDRAULICS

TIME: THREE (3) HOURS

CAUTION!! READ INSTRUCTIONS VERY CAREFULLY!!

INSTRUCTIONS: ANSWER FIVE QUESTIONS OUT OF EIGHT.

ALL QUESTIONS CARRY EQUAL MARKS. ANSWER TWO QUESTIONS FROM SECTION B, AND AT LEAST ONE FROM EACH OF SECTIONS A AND C. BUT NOT MORE THAN TWO.

SECTION A: SOIL SCIENCE

Q1. An air-dry soil sample weighing 0.617 kg is brought to the soils laboratory for mechanical grain-size analysis.

The laboratory data are as follows:

Sieve size (mm)	Mass retained (g)
4.750	28
2.000	42
0.850	48
0.425	128
0.250	221
0.150	86
0.075	40
Pan	24

- (a) Determine the percentage finer than each sieve and plot the particle-size distribution curve for this soil sample on a semi-logarithmic chart.
- (b) Determine the effective size.
- (c) Determine the median size.
- (d) Calculate the coefficients of uniformity and curvature.

[20 marks]

Q2. (a) The following were obtained as results of a shrinkage limit test:

- *Initial volume of soil in a saturated state is 24.6cm^3
- *Final volume of soil in a dry state is 15.9cm^3
- *Initial mass in a saturated state is 44g.
- *Final mass in a dry state is 30.1g.

Determine the shrinkage limit of the soil.

(b) With the use of the Cassagrande Apparatus, a liquid and plastic limit determination on a soil gave the following results:

LIQUID LIMIT TEST

Test No.	Tin mass (g)	Tin+wet soil(g)	Tin+dry soil
1	23.68	40.86	34.68
2	22.93	42.62	35.78
3	26.27	38.02	34.27

PLASTIC LIMIT TEST

Test No.	Tin mass (g)	Tin+wet soil(g)	Tin+dry soil
1	25.34	32.17	31.01
2	24.83	30.48	29.51

- (i) Determine the plasticity index of the soil.
- (ii) Which one of the two tests above tests have been done due to the use of the Cassagrande Apparatus? [20 marks]

- Q3. Sketch the rock cycle and explain how the igneous, sedimentary and metamorphic rocks are formed. [20 marks]

SECTION B: ROADS

Attempt only two (2) questions from this section.

- Q4. Outline the difference in meaning between the running and journey speeds. Indicate also the three (3) methods that are used to obtain the running and/or journey speed. [20 marks]
- Q5. Explain what geometric design is concerned with, without leaving out the features that are considered in geometric design and what influences the design of these features. [20 marks]
- Q6. What do you understand by design speed? Outline as well the primary factors that affect the choice of a design speed. [20 marks]

SECTION C: HYDRAULICS

- Q7. The 1mm - 1 hour Unit Hydrograph for the catchment of a certain stream is given below.

Time (hrs)	0	1	2	3	4	5	6
UH (m^3/s)	0	3.0	6.0	4.0	2.0	1.0	0

The following rainfall data (of a storm event) were collected from a rain gauge station sited close to the downstream border of the catchment area of this stream. The baseflow in the stream (during the storm event) is a constant $20 m^3/s$. The total volume of surface runoff resulting from this storm event was $2,592,000m^3$.

Time (hrs)	0	1	2	3	4	5	6
RAINFALL (mm)	0	30	25	20	10	30	0

- (a) Explain the difference in using runoff-coefficients and the ϕ -index when estimating surface runoff resulting from a storm event.
- (b) Determine the surface area (in km^2) of this catchment.
- (c) Determine the ϕ -index (in mm/hr) for this rainfall event.
- (d) Estimate the peakflow (m^3/s) at the downstream border of the catchment area and its time of occurrence (in hrs).
- (e) Determine the runoff coefficient (in %) for this rainfall event.

Remark:

In case you were unable to determine the ϕ -index (Q7c), assume this ϕ -index to be 10mm/hr.

- Q8. (a) With the aid of a sketch, explain the difference between a confined and an unconfined aquifer.
- (b) (i) With the aid of a sketch, explain the difference between the permeability and transmissivity of a confined aquifer.
- (ii) Give the units of measurement of permeability and transmissivity.
- (c) Two boreholes (borehole A and borehole B) penetrate 100m deep into an unconfined aquifer. They are sited 120m apart. The water is being pumped from borehole A at a rate of 1.0 l/s and from borehole B at a rate of 2.0 l/s. The following data are given:
- permeability of aquifer: 1.31 m/day
 - diameter of borehole A: 400mm
 - diameter of borehole B: 400mm
 - original piezometric water level: 30m below ground level.
 - drawdown in borehole A (when both borehole A and B are being pumped) 13.80m
 - drawdown in borehole B (when only borehole B is being pumped) 10m

- (i) Determine the drawdown in borehole A (in m) when only borehole A is being pumped.
- (ii) Determine the drawdown in borehole B (in m) when both borehole A and borehole B are being pumped.

Remark:

In case you were unable to determine the drawdown in borehole A when only borehole A is being pumped (Q8c(i)), assume this drawdown to be 4m.

[20 marks]

END OF EXAMINATION & GOOD LUCK!!

THE UNIVERSITY OF ZAMBIA
UNIVERSITY FIRST SEMESTER EXAMINATIONS - MARCH, 1998

CE 369
FLUID MECHANICS

TIME: THREE (3) HOURS

INSTRUCTIONS: ATTEMPT ANY FIVE (5) QUESTIONS. ALL QUESTIONS CARRY EQUAL MARKS.

- Q1. (a) Two distinct types of flow can be distinguished in the flow of a real fluid. State and describe these two types of flow.
- (b) Show that the loss of head when a pipe undergoes a sudden increase in diameter is given by $(v_1 - v_2)^2 / 2g$ where v_1 is the velocity in the smaller pipe upstream of the enlargement and v_2 that in the larger pipe.
- (c) A pipe increases suddenly in diameter from 0.5m to 1m. A mercury U-tube has one leg connected just upstream of the change and the other leg connects to the larger section a short distance downstream. If there is a difference of 35mm in the mercury levels, the rest of the gauge being filled with water, find the discharge.
(4+8+8)

- Q2. (a) What is meant by open channel flow? State Chezy's equation for open channel flow. To what type of open channel flow is the Chezy equation applicable?
- (b) A rectangular open channel has a width B of 4.5m and a slope of 1 vertical to 800 horizontal. Find the mean velocity of flow v and the discharge Q when the depth D of water is 1.2m, if C in the Chezy formula is 49 in SI units.
- (c) An open channel is V-shaped, each side being inclined at 45° to the vertical. If the rate of flow Q is $45 \text{ dm}^3/\text{s}$ when the depth of water at the centre is 225mm, calculate the slope of the channel using the Chezy formula, assuming that C is 49 in SI units.
(4+8+8)

- Q3. (a) Define Fluid Mechanics. How does fluid mechanics differ from "solid-body" mechanics?
- (b) What is meant by the viscosity of a fluid? A fluid has absolute viscosity 0.0010 Pas and relative density 0.913. Calculate the velocity gradient and the intensity of shear stress at the boundary and at points 1cm, 2cm and 3cm from the boundary, assuming a straight line velocity distribution.
- (c) A mercury U-tube manometer is used to measure the pressure above atmospheric of water in a pipe, the water being in contact with the mercury in the left-hand limb. Sketch the arrangement and explain its action.
- (d) If the mercury is 30cm below A (Fig 1) in the left limb and 20cm above A in the right-hand limb, what is the gauge pressure at A? Relative density of mercury = 13.6.
(5+5+5+5)

- Q4. (a) Show that for fluids at rest there can be no shear stresses in the fluid.
 (b) State and prove Pascal's law.
 (c) A circular lamina 125cm in diameter is immersed in water so that the distance of its perimeter measured below the water surface varies between 60cm and 150cm. Find the total force due to the water acting on one side of the lamina, and the vertical distance of the centre of pressure below the surface.

(4+8+8)

- Q5. (a) What is meant by continuity of flow and under what conditions does it occur?
 (b) Oil flows through a pipeline (Fig.2) which contracts from 450mm diameter at A to 300mm diameter at B and then forks, one branch being 150mm diameter discharging at C and the other branch 225mm diameter discharging at D. If the velocity at A is 1.8m/s and the velocity at D is 3.6m/s, what will be the discharges at C and D and the velocities at B and C?
 (c) A fluid is flowing in a tapering pipe (Fig.3). At section AB, the area of cross-section is a_1 and the velocity v_1 and at section CD the corresponding values are a_2 and v_2 . Derive an expression for the rate of change of momentum of the fluid between the two sections.

(4+8+8)

- Q6. (a) Distinguish between steady and unsteady flow; and between uniform and non-uniform flow.
 (b) Write down Bernoulli's equation in its usual form and list the conditions under which it is applicable.
 (c) Explain how provision can be made in Bernoulli's equation for loss of energy occurring between two points in a stream of liquid.
 (d) A conical tube is fixed vertically with its smaller end upwards. The velocity of flow down the tube is 4.5m/s at the upper end and 1.5m/s at the lower end. The tube is 1.5m long and the pressure head at the upper end is 3m of the liquid. The loss in the tube expressed as a head is $0.3(v_1 - v_2)^2 / 2g$ where v_1 and v_2 are the velocities at the upper and lower ends. What is the pressure head at the lower end?

(3+5+3+9)

- Q7. (a) A pipeline connecting two reservoirs having a difference of level of 6m is 720m long, and rises to a height of 3m above the upper reservoir at a distance of 240m from the the entrance before falling to the lower reservoir. If the pipe is 1.2m in diameter and the frictional coefficient $f = 0.01$, what will be the discharge and the pressure at the highest point of the pipeline?
 (b) Water is discharged from a reservoir into the atmosphere through a pipe 39m long. There is a sharp entrance to the pipe and the diameter is 50mm for 15m from the entrance. The pipe then enlarges suddenly to 75mm in diameter for the remainder of its length. Taking into account the loss of head at entry and at the enlargement, calculate the difference of level between the surface of the reservoir and the pipe exit which will maintain a flow of $2.8 \times 10^{-3} \text{ m}^3/\text{s}$. Take f as 0.0048 for the 50mm pipe and 0.0058 for the 75mm pipe.

(10+10)

FIG. 1

Q3

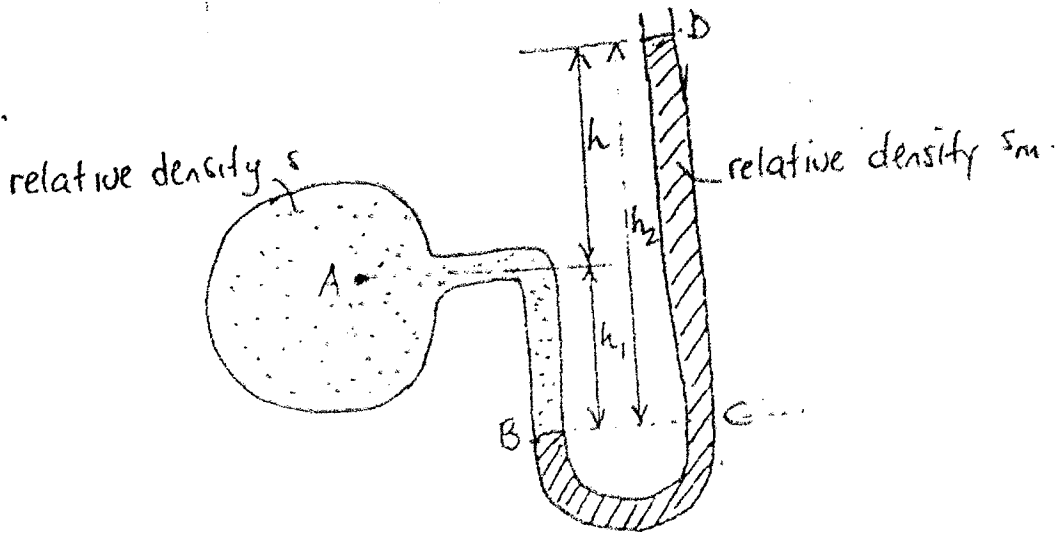

FIG. 2

Q5

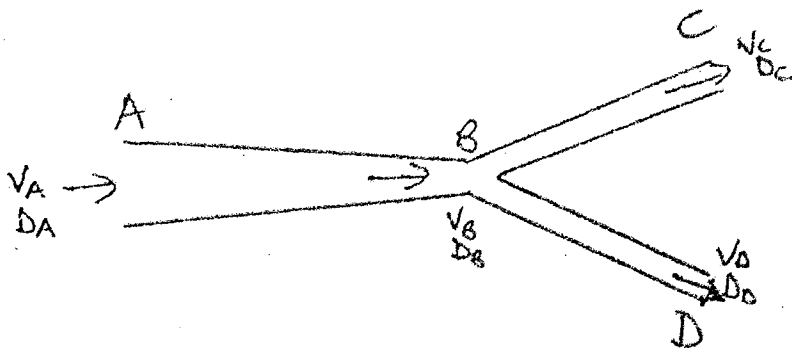
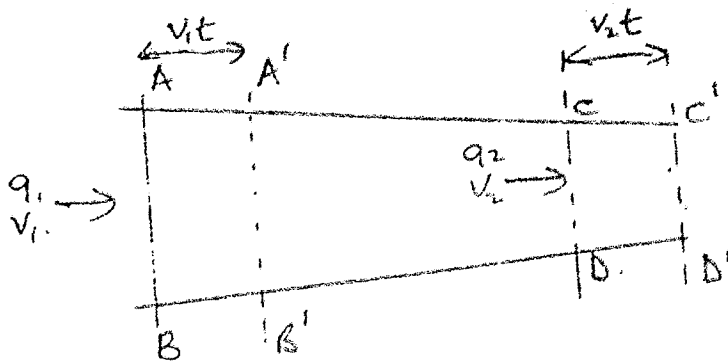

FIG. 3

Q5



THE UNIVERSITY OF ZAMBIA
UNIVERSITY EXAMINATIONS - 1996/98

CE 431 STRUCTURAL ENGINEERING

TIME: 3 HOURS

ANSWER: FIVE QUESTIONS AS FOLLOWS:
THREE QUESTIONS FROM SECTION A AND
TWO FROM SECTION B. ALL QUESTIONS CARRY
EQUAL MARKS

NOTE: OPEN BOOK

SECTION A: STRUCTURAL MASONRY

1. (a) What are the common masonry units in Zambia?
(b) For a typical interior wall shown in Figure 1, constructed using 400x190x140 hollow masonry units, check whether the wall can withstand the design load. Walls are spaced at 5m centres, both directions. Assume access to carry only for cleaning and maintenance. Assume the following loading:

$$\begin{aligned} \text{Density of Concrete} &= 24 \text{ kN/m}^3 \\ \text{Imposed loading on roof slab} &= 0.75 \text{ kN/m}^2 \\ \text{Dead Load on floors, } G_k &= 5.0 \text{ kN/m}^2 \\ \text{Live Load on floors, } Q_k &= 1.5 \text{ kN/m}^2 \end{aligned}$$

- (c) If the wall is an exterior one, list the main considerations in the design?

(5+12+3)

2. The wall shown in Figure 2a is a double wall constructed using modular bricks 190x90x90. The walls have cast in-situ reinforced concrete roof slabs on top and bottom. The compressive strength of the units is 25N/mm^2 and mortar designation iii is used. Assuming normal manufacturing and construction procedures, determine:

- (a) What load the wall can carry?
(b) If instead, a cavity wall stiffened by piers of 190mm width, at 1.9m centres and of thickness 90mm, as shown in Figure 2b are used, what would be the capacity of the wall?
(c) What is the minimum thickness for the cavity in (b)?

(9+9+2)

3. A 150mm thick (nominal) concrete block boundary wall of height 2.4m is supported on a reinforced concrete strip foundation. The construction joints of the walls are at 4.0m centres.

(a) If the wall has short return walls at ends, determine the lateral load carrying capacity against wind for the wall, if the wall is made from solid blocks of compressive strength 15 N/mm^2 in mortar type iii.

(b) If in this case, the wall has bonded return walls, what would be the lateral load carrying capacity against wind, if hollow blocks of 10 N/mm^2 in mortar type iii are used.

(10+10)

4. (a) What is meant by progressive collapse? List 3 types of loads that may lead to this.

(b) For the inner wall, 140mm thick solid blockwork shown in Figure 3, which is part of a six-storey building, determine whether the tie force can be wholly resisted by friction on the contact surfaces, A and B, indicated. Assume $\mu=0.6$ for the contact surfaces.

Cavity thickness	= 100 mm
Density of concrete	= 24 kN/m^3
Load on Roof (access only)	= 1.5 kN/m^2
G_k on floor	= 2.5 kN/m^2
Q_k on floor	= 1.5 kN/m^2

Assume clear distance between walls across the building is 4.86m. The slabs are simply supported between walls. Interior walls are plastered on both sides, exterior ones only on the inside

(4+16)

SECTION B: TIMBER ENGINEERING

5. (a) What is meant by the Equilibrium Moisture Content for timber and what values are used in Zambia?
- (b) List factors that may affect the seasoning of timber in air.
- (c) For the mono-pitch truss shown in Figure 4, obtain solid cross-sections for the most heavily loaded members in Tension and Compression, respectively. The timber is Mukwa, in an inside location. Assume nodal loads on the truss are as shown in the figure. Design the compression members using Madison formula. Assume $W=2.5 \text{ kN}$ and $W_c=0.30 \text{ kN}$.

(3+2+15)

6. The coped beam in Figure 5 is supported on 100mm thick bearings made out of timber. The beam spans 5.5m over simple supports. The beam is of dimensions 125x350mm and is in an inside location. Assuming the beam is made from Pine timber, what is the maximum uniformly distributed loading it can carry? For this loading, check whether deflection requirements are satisfied, if it supports asbestos ceiling panels. Also check the bearing stress at the supports.

(12+4+4)

7. (a) By using the German design approach, design a rectangular solid column using Mukwa, in an outside location. The vertical load to be transmitted is 100 kN. The column is assumed hinged top and bottom and is of width 150mm. The column is of height 2.4m.
- (b) Assuming that the column also resists a horizontal load of 35 kN/m, in addition to the vertical load, check whether the designed section in (a), satisfies strength requirements.

(12+8)

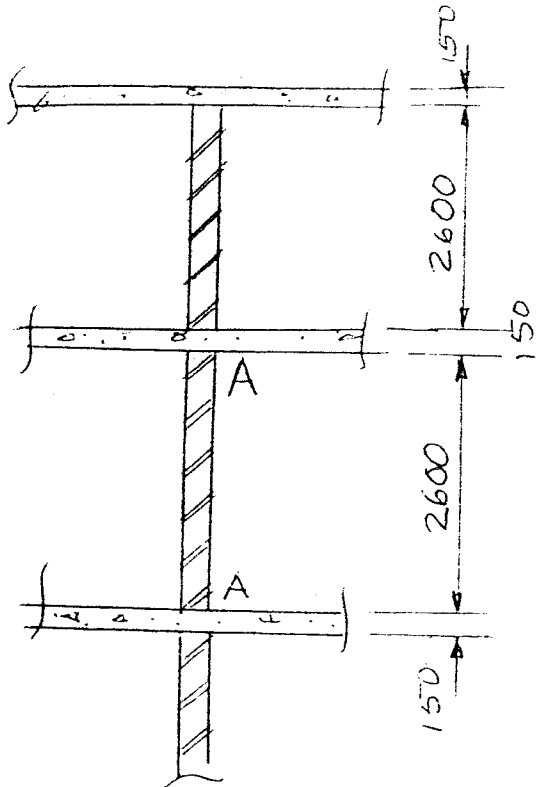

Figure 1

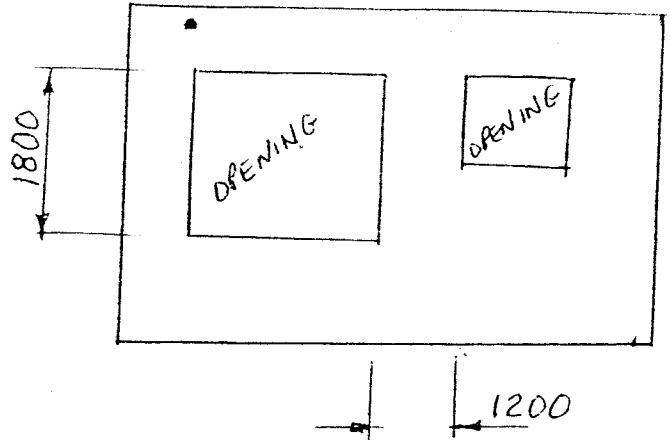

Figure 2a

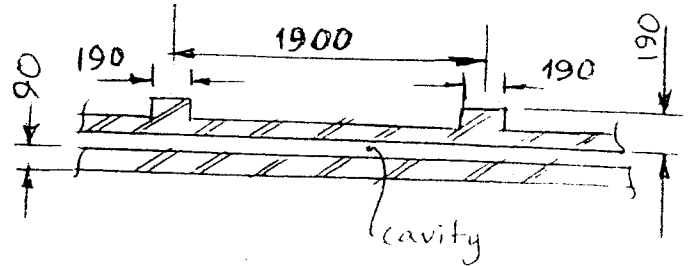

Figure 2b

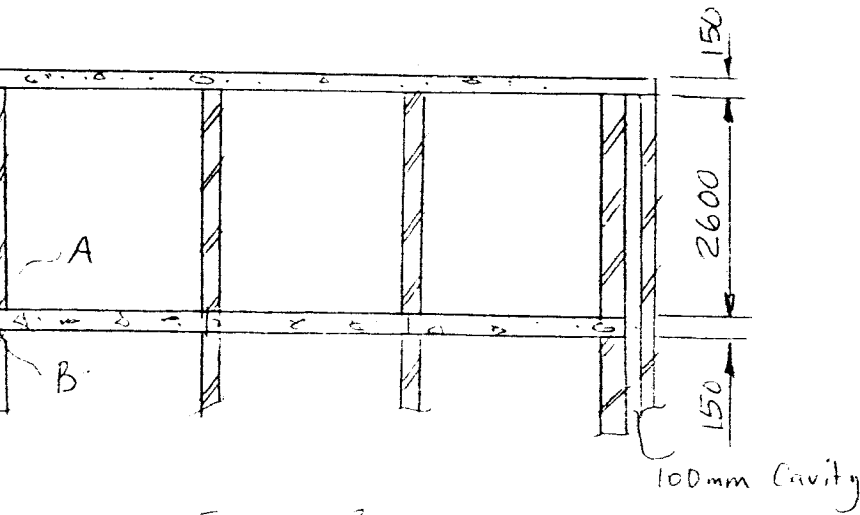

Figure 3

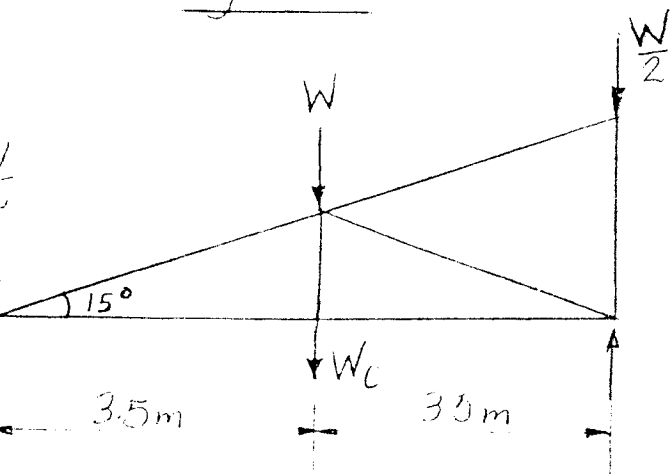

Figure 4

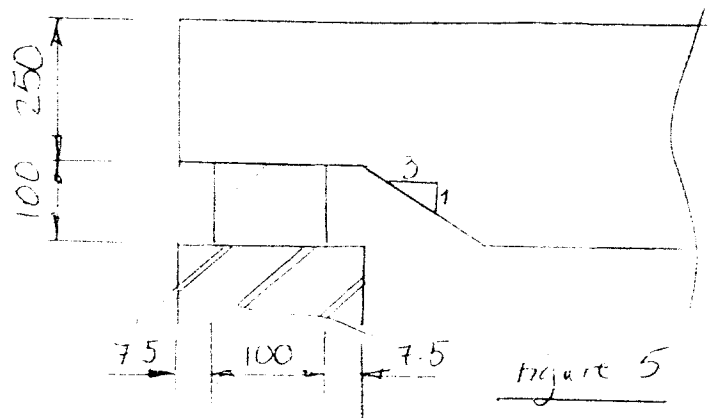

Figure 5

THE UNIVERSITY OF ZAMBIA
UNIVERSITY EXAMINATIONS MARCH 1998
CE 461 HYDROLOGY

TIME: THREE (3) HOURS

ANSWER: QUESTION 1 AND ANY THREE FROM SECTION B.

SECTION A

THIS QUESTION IS COMPULSORY. YOU MUST ANSWER IT.

1. A storm over the catchment shown in the figure below generates simultaneously at A and B the hydrograph listed below:



Hours	Q(m ³ / s)
0	12
6	33
12	70
18	49
24	42
30	33
36	20

Use the Muskingum stream routing technique to determine the combined maximum discharge at C. The travel time for the centre of mass of the flood between A and C is 12 hours and the factor $x = 0.17$. Any local inflow is neglected.

(31 MARKS)

SECTION B**ANSWER ANY THREE QUESTIONS**

2. The following data are hypothetical annual rainfall figures (in mm) for four stations in and around Lusaka. The average values for the airport and Makeni have not been established.

	1981	1982	Annual Average over past 22years
University	670	1215	887.5
Met.Office	540	1052.5	782.5
Airport	487.5	1060	-
Makeni	827.5	1355	-

- a) Predict the Met. Office 'annual average' from that of the University over the two years of record. Compare with the value given.
 b) Forecast the annual average for the Airport and Makeni based on the University and Met. Office.
 c) Discuss problems you might encounter when using data of the following type for hydrological applications:

Day	1	3	7	8	11
Rainfall (mm)	6	40	16	8	1

(23 MARKS)

3. The distribution of annual daily mean inflows to a certain reservoir are given by the Extreme Value Type I (Gumbel) Distribution where:

$$Q_T = Q_{av} + \sigma (0.78 y - 0.45)$$

$$p' = e^{-e^{-y}}$$

Below are the annual mean daily inflows (in m^3 / s) to a reservoir during 20 consecutive years:

7.31	6.90	6.64	5.08	5.37	5.75	7.30	7.22	6.48	5.20
6.38	5.51	5.65	5.82	5.81	6.30	6.53	6.12	6.06	6.07

The mean and standard deviation of the data are 6.175 and 0.68 ($\times m^3 / s$) respectively.

- a) Determine the annual maximum mean daily inflow with a 100 year return period.
 b) What is the probability of this 100-year value occurring in any period of 10 consecutive years.
 c) The Environmental Council of Zambia is planning to establish surface water quality standards in Zambia. Discuss hydrological phenomenons that will have to be taken into account.

(23 MARKS)

4. Consider a sub-basin within the Kafue River Basin. The data of a rainfall storm and of the corresponding discharge at the outlet of the sub-basin are given in the table below. The baseflow has a constant value of $25 \text{ m}^3 / \text{s}$. The phi - index has been computed and is $14.2 \text{ mm} / \text{hr}$.

time (min)	rainfall (mm)	discharge (m^3 / s)
0	0	22
30	12	23
60	18	35
90	6	71
120	10	103
150	2	111
180		100
210		86
240		59
270		47
300		28

- a) What is the area of the sub-basin?
- b) What would be the depth of rainfall lost if the following rainfall storm was recorded on the sub-basin:

time (min)	rainfall (mm)
0	0
30	20
60	24
90	7
120	5
150	10

(23 MARKS)

5. A rectangular parking lot 100m wide and 200m long has an estimated time of concentration of 20 minutes. Of the 20 minutes concentration time, 15 minutes is required for overland flow across the pavement to the longitudinal gutter along the centre of the lot. A rain of 50 mm / hr falls on the lot for 5 minutes and then stops abruptly. If the runoff coefficient is 0.85, determine the peak flow, in m^3 / s , past point A.

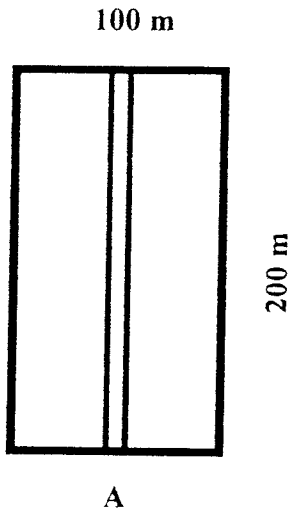

(23 MARKS)

6. Four 300 mm wells fully penetrate an unconfined aquifer of 60 m depth and hydraulic conductivity K of 10 m / day. Three of the wells are pumping wells whilst the fourth one is a recharge well. The wells are all located 50 m from point X. The drawdown in the well caused by the pumping of one well only is 4.6 m. The flow is steady and all pumps have the same discharge of $1000 m^3 / day$. Calculate the drawdown at X.

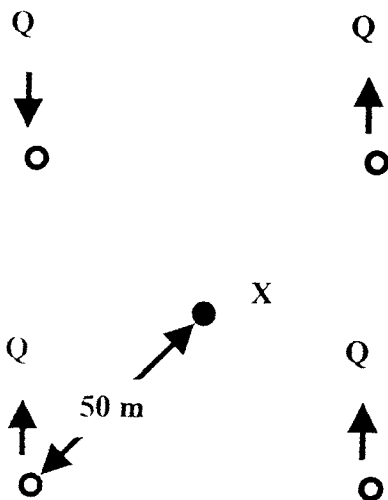

(23 MARKS)

END OF EXAMINATION

UNIVERSITY OF ZAMBIA
UNIVERSITY EXAMINATIONS - MARCH, '98
CE 531
REINFORCED AND PRESTRESSED CONCRETE DESIGN

TIME : THREE AND HALF (3.5) HOURS

ATTEMPT : ALL QUESTIONS

OPEN BOOK

Figure 1 shows a first floor plan and a section of a building structure. The first floor is for general office use. Materials to be used on the site are grades 30 and 460 concrete and steel respectively. A minimum of 1 hour fire resistance is required to all structural elements. Roofing sheets weighing 20 kg/m^2 are to be used. The weight of steel trusses, purlins, ceiling and services in the roof may be taken as 0.3 kN/m^2 . The live load on the roof is 1.5 kN/m^2 . Weight of brickwork is 21 kN/m^3 .

QUESTION ONE

Determine all loads acting on Beam B1

(20 MARKS)

QUESTION TWO

- (i) Use the loads shown in the line diagram in Figure 2, to analyse Beam B1 for the load case with maximum loading on the cantilevers and minimum loading on span BC. Draw a bending moment and shear force diagram.
(15 MARKS)
- (ii) What is the significance of analysis of this load case with respect to the design of the span BC of the beam? What is the limitation of this load case with respect the design of the same span?
(5 MARKS)

QUESTION THREE

- (i) For Beam B1 analysed in Question One, calculate and show the position of bending steel required at the supports.
(15 MARKS)
- (ii) State three possible advantages of using an upstand beam in stead of a down stand beam in this case?
(5 MARKS)

QUESTION FOUR

- (i) Determine the maximum design values of reactions at B and C. (Use loading shown on Figure 2) (5 MARKS)
- (ii) Assuming that Column C1 carries the reaction at the simple support C and a moment of 30 kNm, use a design chart to design and sketch a suitable square short column section. The column is braced and the connections at both ends, though not specifically designed to provide restraint to rotation of the column will, nevertheless, provide some nominal restraint. Use a minimum cover of 40 mm (15 MARKS)

QUESTION FIVE

Column C1 carries the reaction at the support and the moment (whose composition is 15 kNm due to dead load and 5.3 kNm due to live load) to a square foundation base. Make a preliminary design of the foundation base, with an area not exceeding 1.5m^2 . (You are required to make all necessary shear checks but not to work out amounts of steel required). The allowable soil bearing pressure is 76 kN/m^2 (20 MARKS)

NOTE : Where specific information is not given, make reasonable assumptions. The assumptions you make must be clearly stated.

END OF EXAMINATION

The University of Zambia

Final examination CE 565
Water Management and Hydraulic structures

27th of February 1998

OPEN BOOK Examination

Instructions to candidates:

1. Candidates must ensure that their computer numbers are clearly written on each used answer booklet and that the numbers of questions answered are entered in the space provided on the front of the booklet.
 2. Please answer any FIVE questions out of SIX.
 3. All questions carry equal mark (20 %). Marks for sub-questions are indicated at the end of each sub-question.
 4. Textbooks, lecture notes, mathematical gadgets and drawing instruments are allowed.
-

Question 1

The data for this question were taken from the Water Management Master Plan in the Republic of Zambia for the period of 1995 to 2015, developed by Yachiyo Engineering Company Ltd. Where necessary, adjustments have been made to make the data more applicable for the question.

In the above mentioned Master Plan the construction for several new dams is recommended. Among them is the proposed Mutundu dam at the Mutundu river, 15 km north of Kitwe. The dam with a volume of 981,000 m³ and an height of about 30 meter will create a reservoir upstream in the valley.

The following data are given (see table in appendix 1):

1. The monthly inflow rates (in m³/s) during a low water period at the site of the proposed dam are given in column 2 of the table;
2. The corresponding monthly pan evaporation and precipitation (in mm/month) are tabulated in columns 3 and 4 respectively;
3. The pan evaporation coefficient which is to be applied: $K_{p,e} = 0.7$;
4. The estimated monthly domestic demands per capita (in liter per capita per day) of drinking water are given in column 5;
5. The proposed pool area is 13.7 km²;
6. The served population of Kitwe, Kalulushi and Mufulira is estimated at 155,500 inhabitants;
7. The demand (given in mm/month) for irrigation foresees two harvests: an early crop and a late crop;
8. The total surface for irrigated agriculture is 8000 ha; ✓
9. For calculations you can use 30 days in every month of the year.

Determine with the help of the tabular method, the required reservoir capacity. Please note the units of the given data !

Question 2

Calculate the probable life of the Kafue Gorge reservoir with an initial reservoir capacity of $800 * 10^6$ m³, if the average annual flood inflow can be calculated from the performance of 5 turbines at a rate of 20.5 m³/s and the average annual sediment inflow is $9.1 * 10^5$ tonnes, $\rho_{\text{sediment}} = 1350$ kg/m³. The life of the reservoir will terminate when 80 % of the initial capacity is filled with sediment. The relationship between the trap efficiency (η) and the capacity-inflow ratio is presented in the table below.

Do so, when:

- the time period is not divided into a number of intervals, i.e. the only "time interval" is from full storage capacity until the moment 80 % of the initial capacity is filled with sediment (3 %)
- the period of time $T_{\text{tot}} = T_1 + T_2 + T_3 + T_4$, where T_n is the time interval when 20 % of the reservoir's capacity is filled with sediment, i.e. the period of time is divided into four intervals. (13 %)
- Compare the results of the two calculations. (4 %)

Table The trap efficiency in relation to the ratio capacity/inflow

Capacity/inflow	0.05	0.06	0.07	0.08	0.09	0.10	0.11	0.12	0.13	0.14
η (%)	76	77.8	79.5	81.5	83	84.5	86	87.1	88.1	88.9

Table - continuation

Capacity/inflow	0.15	0.16	0.17	0.18	0.19	0.20	0.25	0.30	0.40	0.50	0.60
η (%)	89.5	90.3	90.8	91.5	92.2	92.6	93.5	94	94.8	95.5	96

Question 3

- Give for the following two designs of a dam (see appendix 2, all measures in meters) the principles of calculation for control of stability. It is not necessary to calculate the results ! (15 %)
 - Indicate how the factor of safety and the factor of stability for reservoir full conditions for all dam's body should be calculated in case of the gravity dam given in figure. Indicate what other maximum stresses should be checked.
 - Indicate for the given embankment dam how the slope stability should be calculated. Which other stresses should be checked ?
- Given the two designs with the required dimensions for which would you opt ? Give some general considerations you would integrate in your decision between a gravity and an embankment dam.. (5 %)

Appendix 1**DETERMINATION OF REQUIRED STORAGE CAPACITY OF THE RESERVOIR
(tabular method)**

1	2	3	4	5	6	7
Month	Inflow at dam site (m ³ /s)	Panevaporation (mm)	Precipitation (mm)	Domestic demand liter/cap. day	Agricultural demand mm/month early crop	Agricultural demand mm/month late crops
January	4.2	119	316	125	0	0
February	8.1	110	230	125	0	0
March	10.7	132	197	125	5	0
April	10	131	70	150	39	0
May	5.3	141	7	150	53	0
June	2.5	134	0	150	60	0
July	1.5	152	0	150	14	78
August	1.0	191	0	150	0	130
September	0.6	226	2	150	0	134
October	0.3	236	36	150	0	93
November	0.4	172	164	125	0	0
December	1.8	122	290	125	0	0
Σ		1866	1312		171	435

Appendix 2

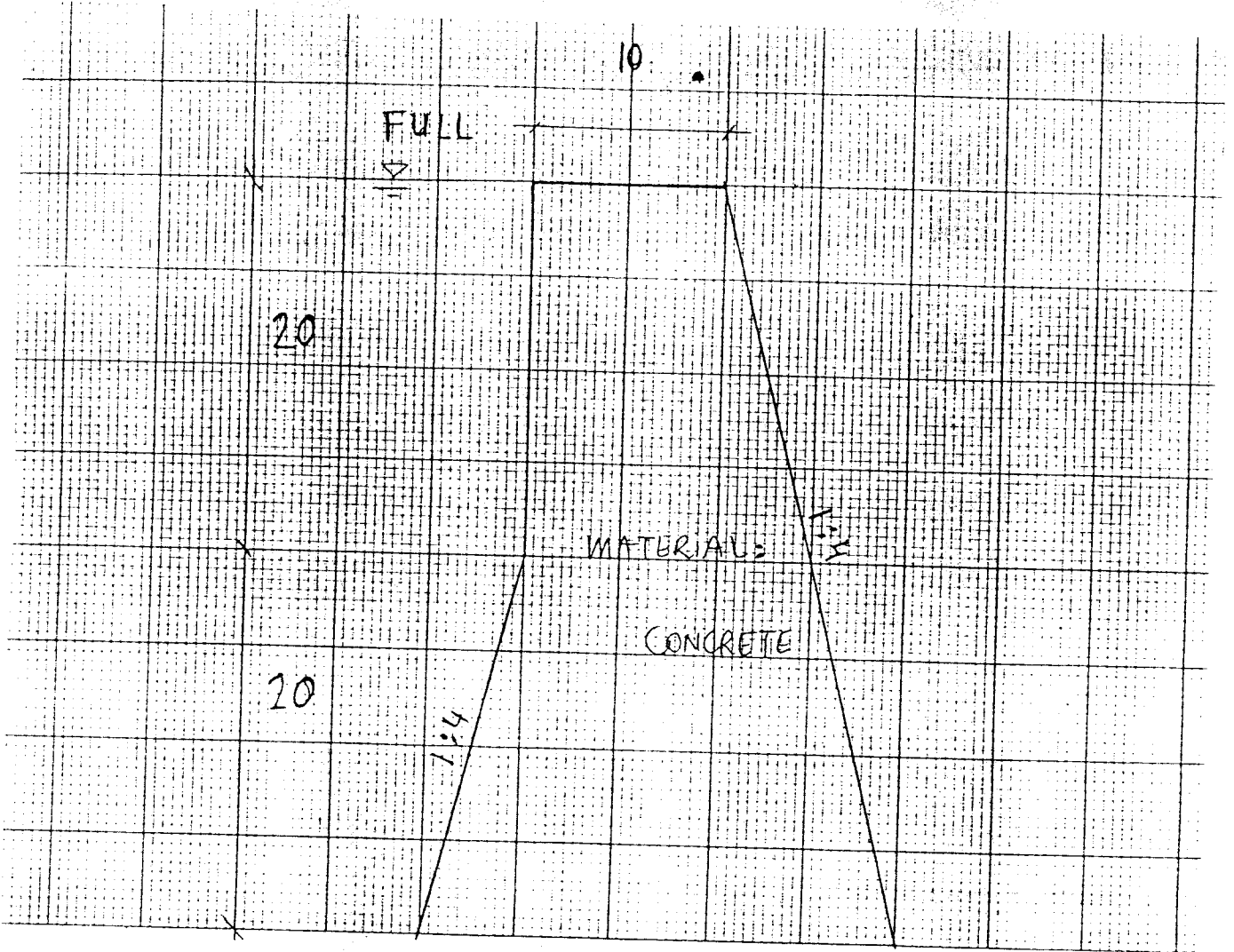

Figure 1 Gravity dam

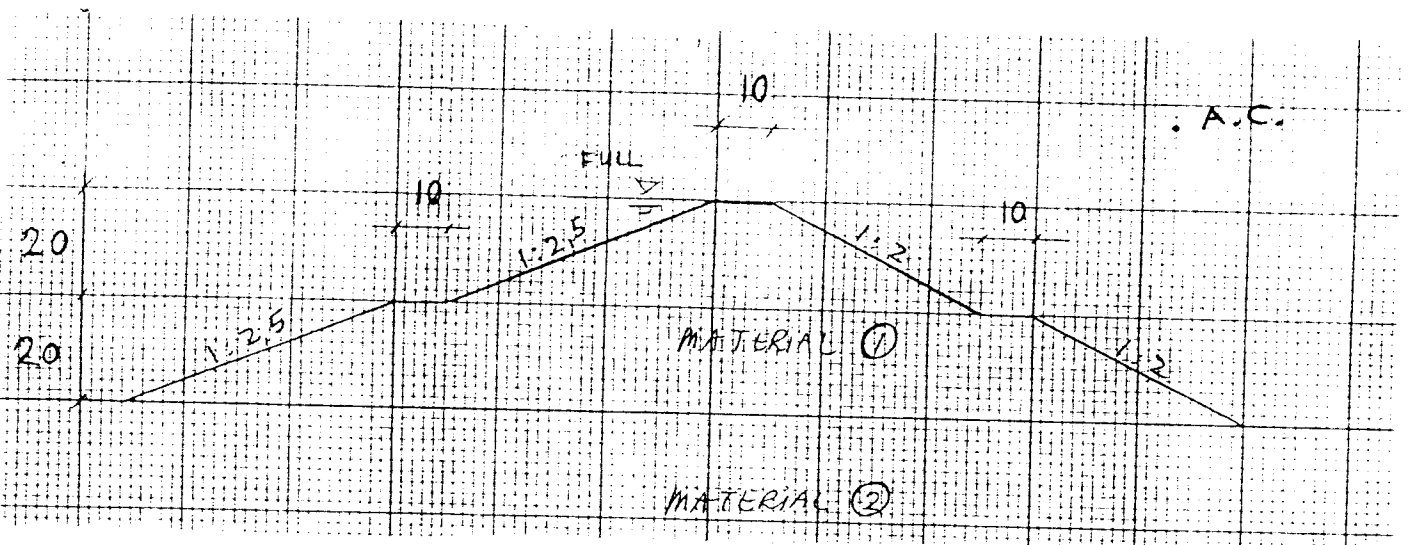

Figure 2 Embankment dam

THE UNIVERSITY OF ZAMBIA
SCHOOL OF ENGINEERING
AGRICULTURAL ENGINEERING DEPARTMENT
FIRST SEMESTER EXAMINATIONS, FEBRUARY/MARCH 1998

EA311 FINAL EXAM
Farm Machinery and Power

INSTRUCTIONS

Time for exam

THREE (3) Hours

Total marks

100

Answer any five questions

Section A and section B should be answered in separate answer booklets

Number of pages for question paper

4

Use table Q3 when answering question 3e and submit this table with your answer script.

Section A

1. Why is cooling necessary in an engine? **[3 marks]**
 - a) What are the common coolants used? Describe a system of classification that is based on the coolant used? **[3 marks]**
 - b) What are the functions in a cooling system of ;
 - i) a radiator **[2 marks]**
 - ii) a fan **[2 marks]**
 - iii) a thermostat **[2 marks]**
 - iv) a pressure cap **[2 marks]**
 - c) List and describe briefly the various types of lubrication systems used on tractors and other farm implements. **[6 marks]**

2. Given a 110mm X 127mm six cylinder engine calculate:
 - a) The crank radius **[2 marks]**
 - b) The piston displacement **[2 marks]**
 - c) The total cylinder volume **[2 marks]**
 - d) The engine displacement **[2 marks]**
 - e) The compression ratio given that (given that $CV=PD/13$) **[3 marks]**
 - f) From the compression ratio give the name of the fuel system and list five main parts of this fuel system. **[6 marks]**
 - g) How is ignition achieved in the engine above? **[3 marks]**

3. What angle has the crankshaft got to travel between one power stroke and the next in a:
 - a) One cylinder four stroke engine **[1 mark]**
 - b) Four cylinder four stroke engine **[1 mark]**
 - c) Two cylinder two stroke engine **[1 mark]**

- d) Six cylinder four stroke engine [1 mark]
- e) Assuming a firing order of 1-5-3-6-2-4 for a six cylinder engine, complete the events in the other cylinders if the events for cylinder 1 are as shown in table Q3 on page 4. (Use this table and submit it with your answer sheet) [12 marks]
- f) Why does a cam shaft run at half the speed of the crankshaft? Illustrate. [4 marks]

Section B

4.

- a) On what basis can primary tillage be differentiated from secondary tillage operation? [3 marks]
- b) Briefly describe four situations that would necessitate secondary tillage operation during crop production process. [4 marks]
- c) Describe how a mouldboard plough works. [5 marks]
- d) Briefly state four field conditions that would favour the use of a disk plough for primary tillage operation. [4 marks]
- e) A rotary cultivator (also known as rotary tiller) is particularly suitable for secondary tillage operation in heavy clay soils. State two ways of how pulverisation of clods may be intensified when using a rotary cultivator [4 marks]

5.

- a) Define the following terms:
 - i) Integrated Pest Management
 - ii) Economic Injury Level
 - iii) Economic Threshold
 [6 marks]
- b) List any four Integrated Pest Control Techniques [2 marks]
- c) Give three advantages and three disadvantages of chemical pest control. [6 marks]
- d) State three factors that influence the chemical application rate when spraying crops using a tractor mounted sprayer and briefly explain the relationship between each factor and the application rate. [3 marks]

- e) Illustrate with appropriate diagrams the spraying patterns exhibited by the three most common sprayer nozzles.

[3 marks]

6.

- a) Outline the static (workshop) calibration procedure of a seed drill.

[10 marks]

- b) During the field calibration of a 20 x 200 mm seed drill with a fluted roller metering mechanism, a farmer collected an average weight of 150 grams of wheat seed from each seed tube after covering 100 m. Given that the recommended seed rate of that particular variety of wheat is 80 kg/ha:

- i) determine whether the farmer need to adjust the seed rate, and if so, briefly explain what he should do to correct the seed rate.

[5 marks]

- ii) State two factors that are likely to cause incorrect seed rate in the field despite accurate static (or workshop) calibration of a seed drill. For each factor, briefly explain the effect it has on the application rate obtained in the field.

[5 marks]

Table Q3

Crank travel	Cylinder number					
	1	2	3	4	5	6
0	power					
30						
60						
90						
120						
150						
180	Exhaust					
210						
240						
270						
300						
330						
360	intake					
390						
420						
450						
480						
510						
540	compression					
570						
600						
630						
660						
690						

END OF EXAM

THE UNIVERSITY OF ZAMBIA
UNIVERSITY FIRST SEMESTER EXAMINATIONS - MARCH 1998

EA 521 - FARM STRUCTURES I

TIME: 3 HOURS

INSTRUCTIONS: ANSWER ANY FIVE (5) QUESTIONS

Question 1

- (a) A reinforced concrete beam shown in Figure Q1 supports the following uniformly distributed loads:

Dead load = 40 kN/m including self weight

Live load = 12 kN/m

In working out the design load, the dead load should be increased by 40 percent and the live load by 60 percent.

The characteristic strength of the concrete is $f_{cu} = 30 \text{ N/mm}^2$ and the characteristic strength of the steel for bending reinforcement f_y is 460 N/mm^2 , while that for shear reinforcement f_{yv} is 250 N/mm^2 . If the effective depth of the beam is 550 mm and the breadth is 300 mm, calculate the area of bending and shear reinforcement required and show the typical arrangement of this reinforcement in section and longitudinal views. Use Tables Q1 and Q2 for calculating shear reinforcement.

Reinforcement bar diameters are:

6 mm, 8 mm, 10 mm, 12 mm, 16 mm, 20 mm, 25 mm, 30 mm

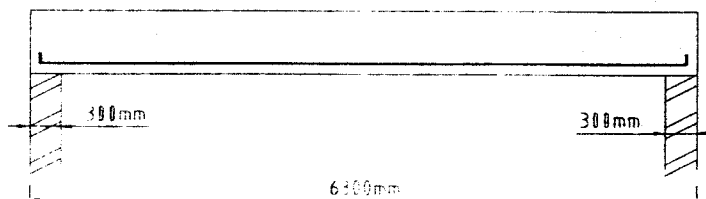

FIGURE Q1

- (b) Pinus kesiya timber purlins are required for a roof structure of pitch 21 degrees. The roof is to be covered by asbestos cement sheeting weighing 24 kg/m^2 . A wind load which acts perpendicular to the roof surface is estimated at 4.6 kN/m^2 . The live load is 1.5 kN/m^2 on a plan area.

The purlins are to be spaced at 1.2 m centres and to span 2.0 m between centres of trusses. The purlins may be considered to be simply supported on the truss rafters. The timber has a density of 524 kg/m^3 and a modulus of elasticity of 9250 N/mm^2 . The allowable bending stress is 7.0 N/mm^2 and the allowable shear stress is 0.81 N/mm^2 .

Using a width of 75 mm for the purlins, determine the required depth to within 25 mm.

Question 2

- (a) List any five factors that affect the selection of building materials.
- (b) Describe two methods of timber preservation giving the appropriate preservative for each method.
- (c) Calculate the amount of materials required to construct a concrete floor 10 m by 6 m by 100 mm thick. The concrete is 1:3:5 nominal mix. Assume that the volume of a 50 kg cement bag is 37 litres, and also that there is a 30% decrease in volume due to mixing and 5% wastage during carting and placing.
- (d) What are the major disadvantages of earth as a building material?

Question 3

- (a) Explain the principle of deflection superposition as applied to the analysis of indeterminate structures and use it in conjunction with the method of virtual work to analyze the truss shown in Figure Q3 (a) whose data is as follows:

Modulus of elasticity is 205 kN/mm^2

Cross sectional areas of the members are

$$AB = BC = 37.3 \times 10^2 \text{ mm}^2$$

$$AD = BD = CD = 30.0 \times 10^2 \text{ mm}^2$$

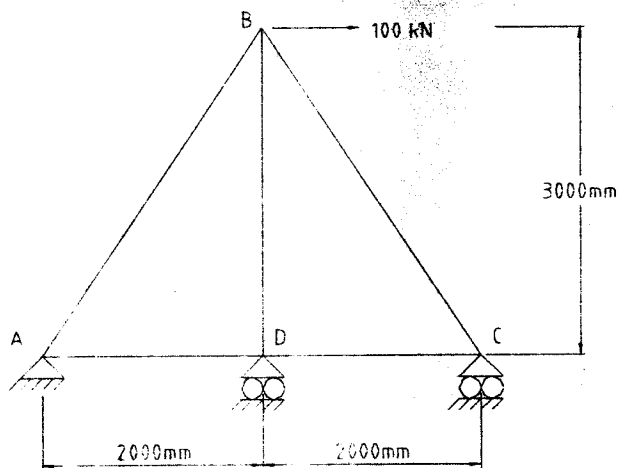

FIGURE Q3 (a)

- (b) Use the moment-area method to compute the maximum deflection of the beam loaded as shown in Figure Q3 (b) if the flexural rigidity EI is constant on the beam.

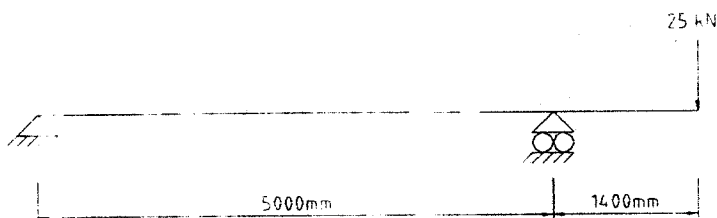

FIGURE Q3 (b)

Question 4

Using suitable sketches, describe the construction of four types of concrete foundations giving typical applications of each type.

Question 5

- (a) Calculate the force on a wall of a square maize storage bin of side length 4 m and retaining maize to a uniform depth of 2 m. Assume that the angle of repose for maize is 27 degrees and the specific weight is 7.7 kN/m^3 .
- (b) Consider a mass concrete dam with the cross section shown in Figure Q5 which retains water to a depth of 3.2 m. Assume a safe bearing capacity of the ground of 300 kN/m^2 , a coefficient of sliding friction at the base of 0.7, and specific weight of concrete of 24 kN/m^3 . Check the wall against possible overturning, sliding at base, ground bearing failure and failure of the wall material.

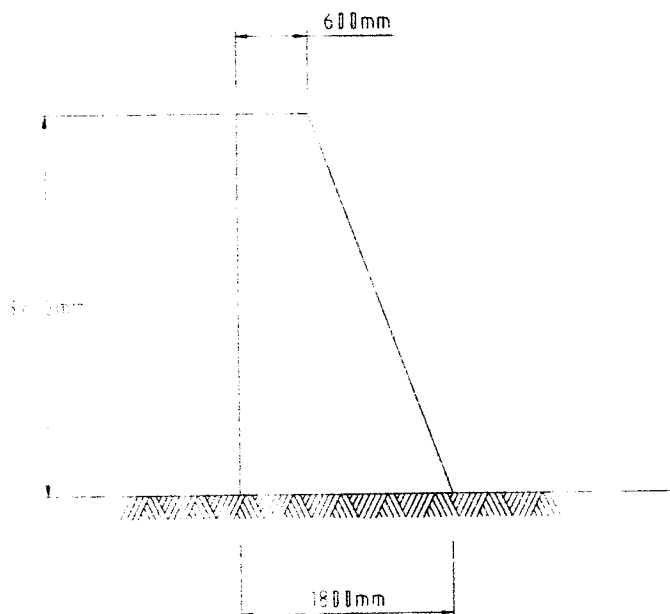

FIGURE Q5

Question 6

Explain the following terms and expressions using suitable illustrations where applicable.

- (i) Concurrent co-planar forces.
- (ii) Moment of inertia of a rectangular section.
- (iii) Primary load effects .
- (iv) Secondary load effects.
- (v) Slenderness ratio for rectangular columns.
- (vi) Characteristic strength of concrete.
- (vii) Modulus of elasticity for timber.
- (viii) Short concrete columns.
- (ix) Stress diagram due to combined bending and compressive loading.
- (x) Angle of repose in granular materials.

TABLE Q1

Values of v_c , design concrete shear stress								
$\frac{100 A_s}{b_v d}$	Effective depth (in mm)							
	125	150	175	200	225	250	300	> 400
< 0.15	0.45	0.43	0.41	0.40	0.39	0.38	0.36	0.34
0.25	0.53	0.51	0.49	0.47	0.46	0.45	0.43	0.40
0.50	0.67	0.64	0.62	0.60	0.58	0.56	0.54	0.50
0.75	0.77	0.73	0.71	0.68	0.66	0.65	0.62	0.57
1.00	0.84	0.81	0.78	0.75	0.73	0.71	0.68	0.63
1.50	0.97	0.92	0.89	0.86	0.83	0.81	0.78	0.72
2.00	1.05	1.02	0.98	0.95	0.92	0.89	0.86	0.80
> 3.00	1.22	1.18	1.12	1.08	1.05	1.02	0.97	0.91

TABLE Q2

Form and area of shear reinforcement in beams		
Value of v (N/mm ²)	Form of shear reinforcement to be provided	Area of shear reinforcement to be provided
Less than $0.5 v_c$ throughout the beam	See note 1	
$0.5 v_c < v < (v_c + 0.4)$	Minimum links for whole length of beam	$A_{sv} \geq 0.4 b_v s_v / 0.87 f_{yv}$ (see note 2)
$(v_c + 0.4) < v < 0.8 \sqrt{f_{cu}}$ or 5 N/mm^2	Links or links combined with bent-up bars. Not more than 50% of the shear resistance provided by the steel may be in the form of bent up bars (see note 3)	Where links only provided: $A_{sv} \geq b_v s_v (v - v_c) / 0.87 f_{yv}$ Where links and bent up bars provided: see 3.4.5.6

THE UNIVERSITY OF ZAMBIA
SCHOOL OF ENGINEERING
DEPARTMENT OF ELECTRICAL & ELECTRONIC ENGINEERING
EE 209 PRINCIPLES OF ELECTRICITY
SEMESTER I FINAL EXAMINATIONS

TIME: 3 HOURS

DATE: MARCH 1998

ANSWER QUESTION ONE AND FOUR OTHER QUESTIONS OUT OF EIGHT
ALL QUESTIONS HAVE TWENTY POINTS EACH

1. (a) For the circuit of Fig 1a, determine the instantaneous steady state voltage across the inductor for $v(t) = 12 \sin(2t + 30^\circ)$.
(b) Use a phasor diagram to find the value of the source current I required to establish a voltage $V = 10 \angle 0^\circ$ in the circuit of Fig 1 b.
(c) Define the concept of power factor of a component in an ac circuit. Give the three nested power factor triangles which can be used to calculate the power factor angle.
(d) Draw diode circuits for two input OR and AND Gates. For each gate give the truth table and briefly describe how the states in the truth table are obtained in the diode circuits.
2. The circuit shown in Fig. 2 is the representation of a transistor amplifier stage. Determine by use of mesh analysis:
 - (a) The current I_0 .
 - (b) The power supplied by the 1.0mV source.
 - (c) The power dissipated in the $2k\Omega$ resistance.
 - (d) The power in the dependent voltage source. Is it supplied or absorbed.
3. An incandescent lamp is supplied by a 220/120 V transformer uses electric energy at the rate of 100W. Determine:
 - (a) The current in the lamp.
 - (b) The electric charge flowing through the circuit per hour.
 - (c) The cost of operation for one year, assuming the lamp is on 10 hrs/day and the cost of electric energy is \$ 0.06 / kWh. 1 US\$ = ZK 1550 (February 1998).
4. (a) Find the voltage across the 8Ω resistance in the circuit of Fig. 4a. Use network reduction and source conversion.
(b) Find the phasor voltage V_{AB} (the potential at point A minus the potential at point B) in the circuit shown in Fig. 4b.
5. Draw the universal resonance curve for both the series and parallel R,L,C resonance circuit. Show the half-power points and the corresponding magnitudes of relative amplitude and circular frequencies in rad / s. Let $\delta = (\omega - \omega_0) / \omega_0$.
For $\delta \ll 1$, what is the ratio of $Y(j\omega) / Y_0$ and $Z(j\omega) / Z_0$. Define bandwidth and half-power point frequencies in terms of R, L, C, ω_0 and the corresponding quality factors Q_p and Q_s .
6. (a) What is the use of the input coupling capacitor in a transistor amplifier stage. What is the normal biasing mode of operation for a transistor to be used as an amplifier.
(b) Draw the typical amplification curves for a transistor in the common emitter configuration together with the collector load line.
(c) Give the ideal dc and ac equivalent circuits for a transistor connected in the common emitter configuration.
7. Give the four ways of performing impedance matching in an ac circuit shown in Fig 7. Why is impedance matching an important consideration in electronic and communication devices and not in high voltage electric power devices.
8. Draw the schematic diagrams for an adaptive speed control system, microprocessor-based temperature control system and a functional representation of a digitally controlled drill press. Briefly describe the process of control in each control system.

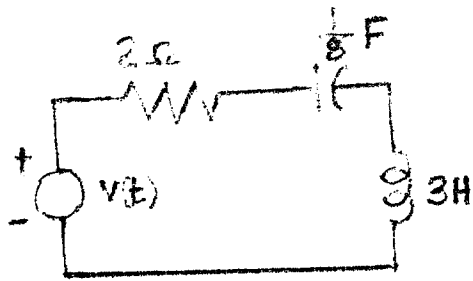

FIG. 1a

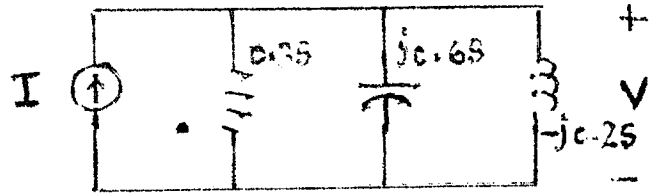

FIG. 1b

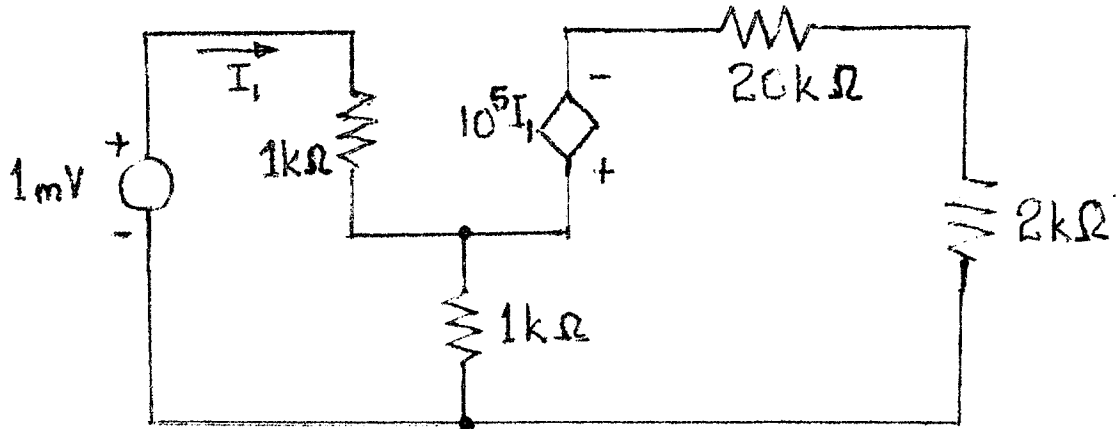

FIG. 2

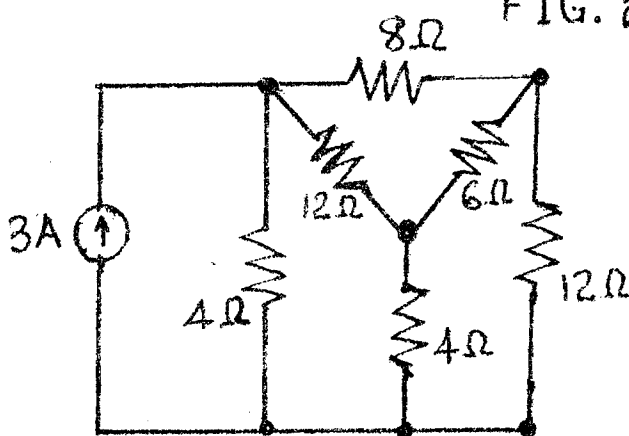
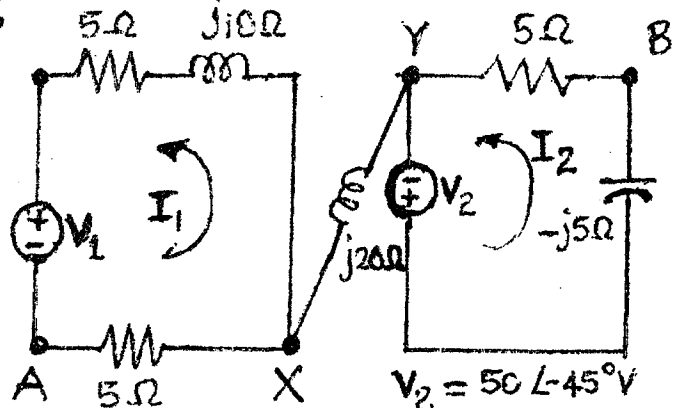

FIG. 4a



$V_1 = 20 \angle 30^\circ \text{ V}$

FIG. 4b

$V_2 = 50 \angle -45^\circ \text{ V}$

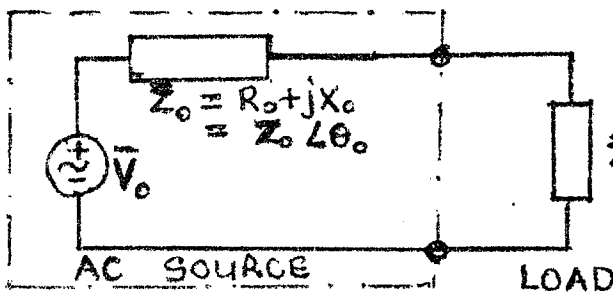

FIG. 7

END OF EE 209 SEMESTER I EXAMINATION

UNIVERSITY OF ZAMBIA
SCHOOL OF ENGINEERING
EXAMINATION - I SEMESTER, March 1998.
EE309 : PRINCIPLES OF ELECTRICITY II

Time: **three hours**
 Answer: **any five questions**
each question carries 20 marks

Question 1

- (i) Find (a) the potential and (b) the field strength and direction at points A and B in Fig 1, due to two small spheres X and Y, 1.0 m apart in air and carrying charges of $+2.0 \times 10^{-8}$ C and -2.0×10^{-8} C respectively. (12 marks)
- (ii) Calculate the intensity and direction at the middle point of the side having charges X and Y if we place a new sphere charge of value -1×10^{-8} C at the corner B of the equilateral triangle (8 marks)

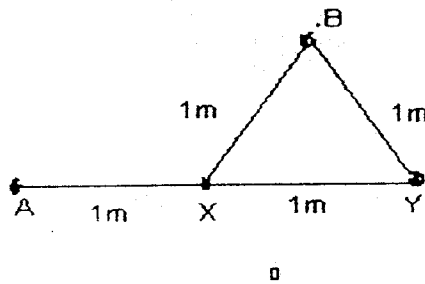

Fig. 1

Question 2

Calculate the energy storage per unit volume (J/m^3):

- (a) electrostatic field in air dielectric ($\epsilon_r = 1$) when electric strength is 80% of the breakdown value 3×10^6 kV/m. (3 marks)
- (b) electrostatic field in air dielectric ($\epsilon_r = 4$) when $E = 1.5 \times 10^7$ v/m; (2 marks)
- (c) magnetostatic field in air for which ($\mu_r = 1$) and a magnetic flux density of 1.4 tesla (3 marks)
- (d) magnetostatic field in iron for which ($\mu_r = 1000$) and a magnetic flux density of 1.4 (2 marks)
- (e) potential energy of water in the earth's gravitational field, with an available vertical height of 400 m; (4 marks)
- (f) chemical energy in a car battery, 12V, 60 A-h, of size 300mmx200mmx150mm; (4 marks)
- (g) heat energy in oil, 40 kJ/g, relative density 0.8; (2 marks)

Question 3.

- (i) An iron ring 100 cm mean circumference is made from round iron of cross-section 10 cm^2 , its relative permeability is 500. If it is wound with 200 turns, what current will be required to produce a flux of 0.1×10^{-2} Wb? (6 marks)
- (ii) The same ring in (i) has a saw cut 2 mm wide made in it. Find the new current required to produce a flux of 0.1×10^{-2} Wb in the air gap, given that the leakage factor is 1.3, and that the relative permeability of the iron under the new condition is 300. (8 marks)
- (iii) In a telephone receiver the size of each of the two poles is $1.2 \text{ cm} \times 0.2 \text{ cm}$, and the flux between each pole and the diaphragm is 300 maxwells. With what force is the diaphragm attracted to the poles? (6 marks)

Question 4

- Each of two transformers, A and B, has an output of 40 kVA. The core losses in A and B are 500 and 250 W respectively, and the full-load I^2R losses are 500 and 750 W respectively. Tabulate the losses and the efficiencies at quarter, half and full load for a power factor 0.8. For each transformer, find the load at which the efficiency is a maximum. (10 marks)
- If the transformers are used for supplying a lighting load (unit power factor) and have their primaries permanently connected to the supply system, compare the all-day efficiencies of the two transformers, assuming the output to be 4 hours at full load, 8 hours at half load and the remaining hours on no load. What would be the saving effected in 12 weeks (7 days per week) with the better transformer if the charge for electrical energy be 42 Kwacha /kWh? (10 marks)

Question 5

- The load shown in Fig. 5 is connected to three-phase, 4-wire, 220V per phase, 50 Hz supply, the phase sequence is A,B,C. Find the currents and their phase angles in each of the four connections. The values of resistances and reactances are written next to each element. (14 marks)
- Plot the phasor diagram. (6 marks)

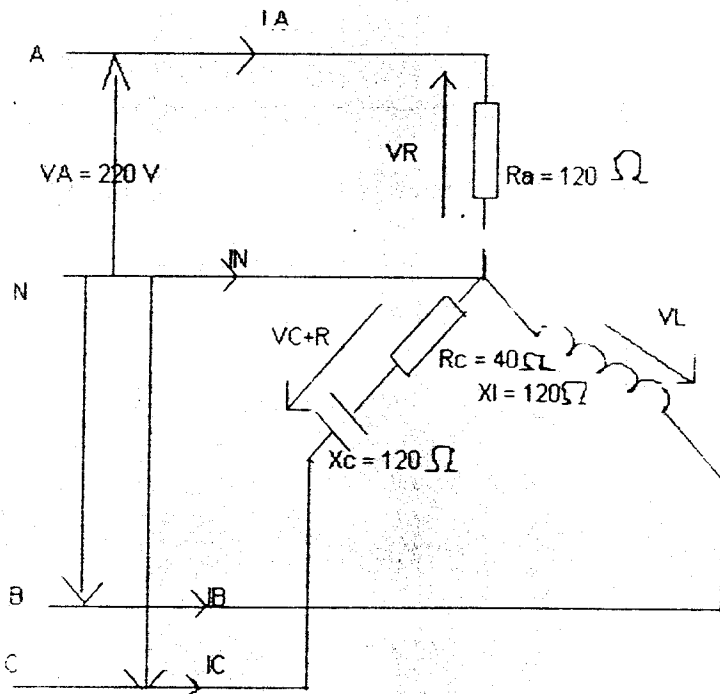

Question 6.

- A 120 V shunt motor draws 23 A and spins at 1200 rpm; $R_A = 0.40\ \Omega$, $R_f = 200\ \Omega$, and P_{rot} (mechanical losses) = 350W. Calculate: (a) the developed power; (b) the output power; (c) the output torque; (d) the efficiency at full load. (4 marks)
- Suppose that when a shunt generator produces 15 kW of load power, we determine that $V_t = 90\text{ V}$ and $E_G = 100\text{ V}$. The field resistance is $80\ \Omega$.
 - find the value of E_G that must exist if the load and the cranking speed are changed such that when on the same machine $V_t = 100\text{ V}$, 25 kW is produced. (This calculation will require the determination of the value of R_a .)
 - for both the originally stated conditions and those in part (a), find V_{LNL} . You should find that each is almost identical to the associated generated voltage.
 - considering the two values of V_t to be V_{LFL} for the two situations described above, find the two corresponding values of the voltage regulation.
 - find the load resistance R_L for each of the two stated operating conditions. (16 marks)

Question 7.

(i) Realise the function

$$F = AC + \bar{A}BC$$

in both NAND and NOR forms. (6 marks)

(ii) Using Karnaugh map, minimise the Boolean function :

(iii)

$$F = \bar{A}\bar{C}D + \bar{A}BCD + BCD + BCD\bar{D}$$

And how many input AND , input OR gates are required to realise the circuit for the new function ? (8 marks).

(iv)) One phase of a three - phase cable is found to be short circuited to the lead sheath. Setting up a Wheastone Bridge as shown in Fig.7, find the distance at which the fault has occurred. The cable resistance is R ohms per metre (6 marks).

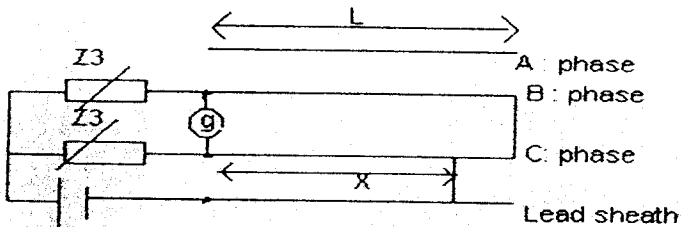

Fig. 7.

Question 8.

For the Fig.8:

- (i) Define the role of C_1 and C_2 , R_1 and R_2 , C_E and R_E (6 marks)
- (ii) Plot the general h - parameter representation assuming C_E very large (7 marks)
- (iii) Determine Z_i , Z_{in} , Z_o , A_v , and A_i for the this amplifier (7marks).

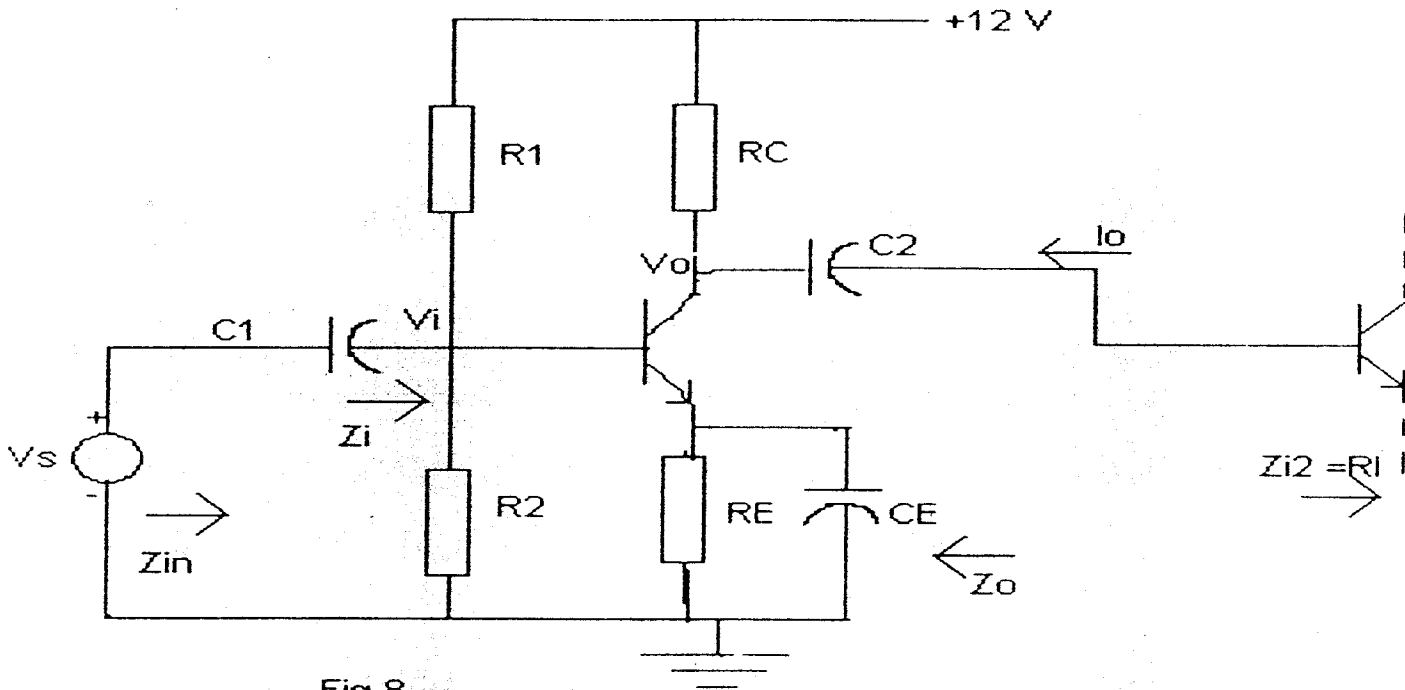

Fig.8

- $R_s = 1\text{ k Ohm}$
- $R_1 = 39\text{ k Ohms}$
- $R_2 = 9.1\text{ k Ohms}$
- $R_C = 3.3\text{ k Ohms}$
- $R_E = 1\text{ k Ohm}$
- $R_L = 1.5\text{ k Ohms}$

- $C_1 = 1\ \mu F$
- $C_2 = 1\ \mu F$
- $C_E = 0.1\ \mu F$
- $h_{fe} = 120$
- $h_{fe} = 2125$

A_v : the voltage gain

A_i : the current gain

Z_i : the input impedance

Z_{in} : the impedance at the input side ($Z_i + R_s$)

Z_o : the output impedance

End

UNIVERSITY OF ZAMBIA
DEPARTMENT OF ELECTRICAL AND ELECTRONICS ENGINEERING

FINAL EXAMINATION, EE311 : ELECTRIC CIRCUITS, March, 1998

Duration: THREE hours

Answer FIVE questions
[20 marks for each question]

Q1: For the circuit shown in Figure-1, calculate the current through the load impedance, Z_L . Solve by Thevenin's equivalent circuit.

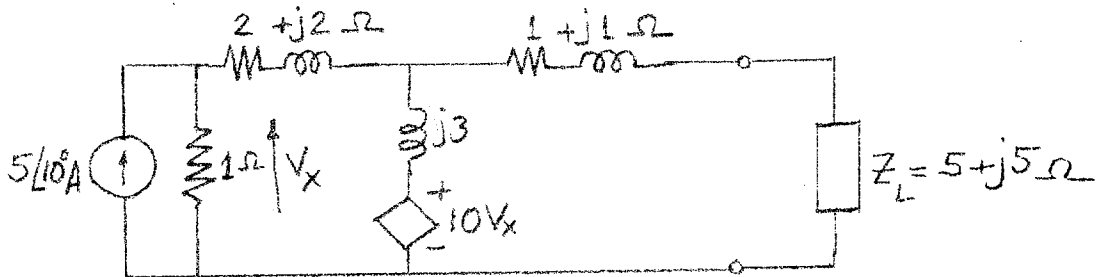

Figure-1

Q2: For the three-phase circuit shown in figure-2, calculate (i) the readings of the of each of the wattmeters. (ii) Which of the two wattmeters you must add to get the total power in the circuit? (iii) Calculate the total theoretical power and check the result by the summation of readings of the two wattmeters .

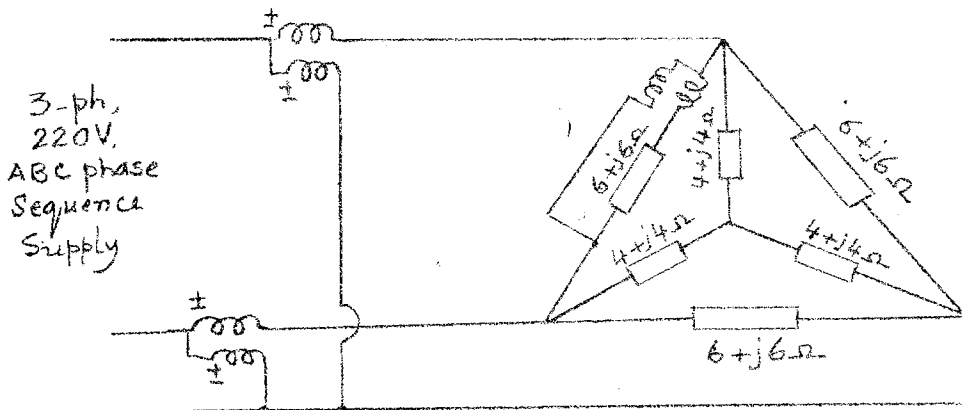

Figure-2

Q3: Calculate the following initial and final conditions of the currents and voltages in the circuit shown in figure-3 after the switch is opened at $t=0$.

$$i_L(0^-), \frac{di_L}{dt} \text{ at } t = 0^+, i_L(\infty), v_C(0^-), \frac{dv_C}{dt} \text{ at } t = 0, \text{ and } v_C(\infty)$$

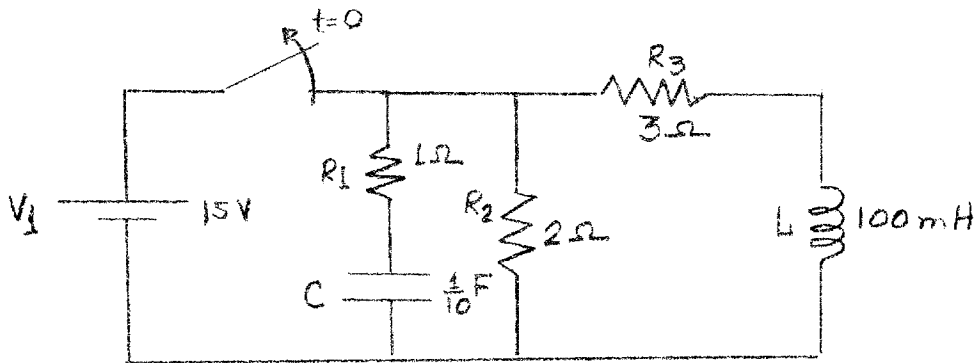

Figure-3

Q4: The figure-4 shows a second order circuit with L and C are in parallel. The switch was closed for a long time. At $t=0$, the switch is closed, (i) find the expression of current through the inductor. (ii) If the current is found oscillatory, calculate the frequency of oscillation and damping factor.

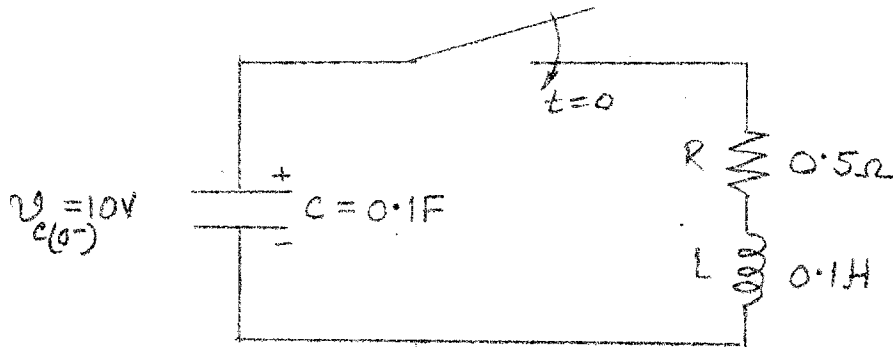

Figure-4

Q5: For the circuit shown in figure-5, the switch was initially open. At $t=0$, the switch is closed, calculate the current, $i(t)$ in the resistance R_3 . Use Laplace Transform to solve.

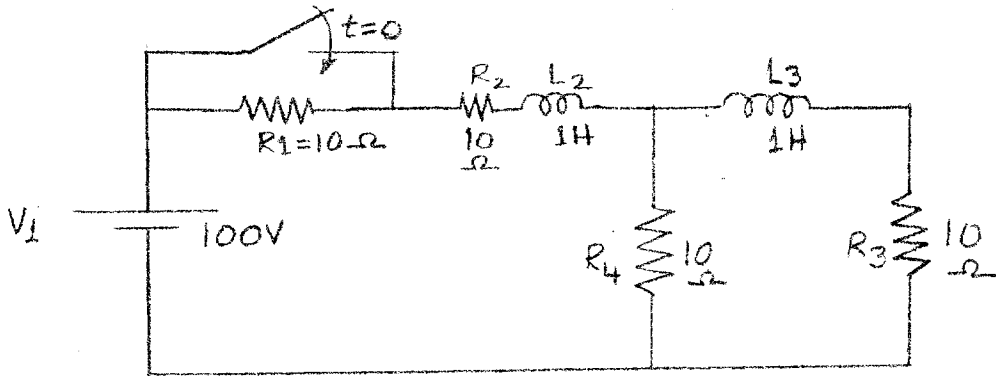

Figure-5

Q6: In the following half-wave rectifying circuit in figure-6, the input voltage is 50 Hz AC with peak voltage of 100V. Calculate the rms value of the output voltages across the capacitor upto the 3rd harmonics.

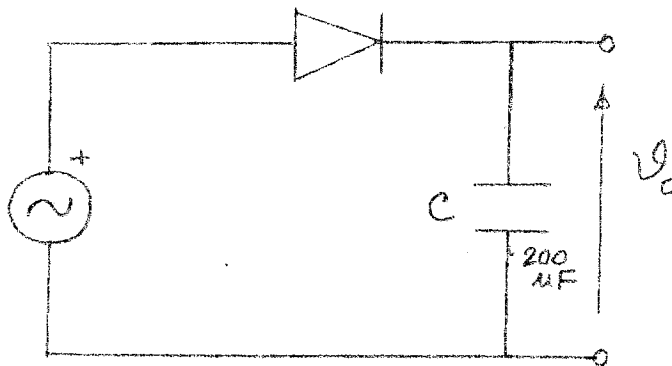

Figure-6

Q7: For the RLC series circuit shown in figure-7, calculate the resonant frequency, ω_0 . Also calculate the half power frequencies and the bandwidth.

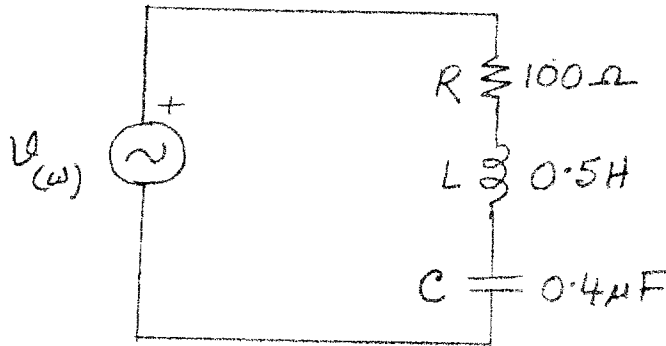

Figure-7

Q8: For the Two-port network shown in figure-8, calculate the Transmission line parameters A, B, C, and D.

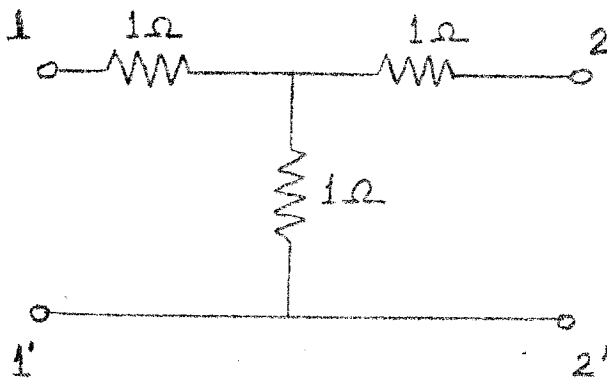

Figure-8

THE UNIVERSITY OF ZAMBIA
SCHOOL OF ENGINEERING
Department of Electrical & Electronic Engineering
University Examinations March 1998

EE321
Electromechanics & Electrical Machines

Time: Three hours.

Answer Five questions.

Permeability of free space $\mu_0 = 4\pi \times 10^{-7} \text{ H/m}$

Permittivity of free space $\epsilon_0 = 8.85 \times 10^{-12} \text{ F/m}$

1.

Given that the illuminance at a point A on a surface which is exactly normal to the incident light and is separated by a distance x from a uniform source is $E_A = \frac{I}{x^2}$, where I is the luminous intensity of the

source, show that for such a surface tilted at an angle θ , $E_A = \frac{I}{x^2} \cos \theta$.

Hence derive the expression for the illuminance at a point C on a horizontal surface which is a distance d from a point B on the same surface directly below a lamp hung on a ceiling at a height h .

[12 marks]

A 500 cd lamp emits light uniformly in all directions and is suspended 5 m above the centre of a 10 m by 20 m working plane. Find the illuminance below the lamp and at each corner of the plane.

[8 marks]

2.

Derive the expressions for capacitance and the maximum electric field intensity E_{max} for a concentric cable of length l , conductor radius R_1 and insulation thickness extending to radius R_2 when subjected to a dc voltage V . Find the conditions for minimum E_{max} for a given value of R_2 .

[8 marks]

A concentric cable has a capacitance of 97.1 nF and links two points 400 m apart. The inner conductor has a diameter of 20 mm and there is room for insulation of thickness 15 mm around the conductor. Calculate

(i) the relative permittivity of the insulation

[4 marks]

- (ii) the maximum electric field intensity in the cable, if it is connected to an 80-kV, 50-Hz ac supply [4 marks]
- (iii) the associated total capacitive current in the cable. [4 marks]

3.

Derive, from basics, an expression for the energy stored per unit volume in a magnetic field of flux density B in a material with relative permeability μ_r .

[8 marks]

An iron ring of cross-sectional area 0.4 m^2 has a circumference of 5 m. A coil of 200 turns is uniformly wound on the ring to give negligible leakage flux. Calculate the stored energy when the coil is energised with a current of 10 A, if the B-H characteristic can be represented in the relevant region by $\mu H = B^3$, where $\mu = \mu_0 \mu_k$ and $\mu_k = 100$ in appropriate units.

[12 marks]

4.

Discuss the experimental methods used to determine the parameters of the equivalent circuit of a single-phase transformer.

[6 marks]

Using the equivalent circuit of a single phase transformer, carefully defining all terms, derive an expression for its regulation when supplying a load of phase angle ϕ_L .

[6 marks]

A 3300/220-V single phase transformer has in its equivalent circuit a total series impedance of $44/60 \angle \theta$ Ω referred to the 3.3 kV primary side. Find the regulation of the transformer when supplying a load current of 45 A at 0.85 lagging power factor.

[8 marks]

5.

Describe the circuit that would be used to measure reactive power in a balanced three phase circuit and prove that such a circuit measures reactive power.

[6 marks]

Find the readings of the two wattmeters used to measure real power on a 3-wire, 240-V system with a balanced delta-connected load of $20/80 \angle \theta$ Ω .

[8 marks]

Show that the 2-wattmeter method can be used to measure total power in a 3-phase system for a general unbalanced situation.

[6 marks]

6.

Derive from faraday's law the expression for total induced voltage in a slip ring machine and in a commutator machine.

[10 marks]

A 4-pole machine has 124 lap wound coils each having 2 turns. The flux per pole is 0.015 Wb. Calculate, assuming sinusoidal field distribution,

(i) the rms voltage across a pair of brushes when running as a single-phase slip ring machine with relative conductor-field speed at 1500 rev/min.

[5 marks]

(ii) the dc voltage appearing across a pair of brushes as a commutator machine at 1500 rev/min.

[5 marks]

7.

(i) The magnetic characteristic obtained for a dc generator at 1200 rpm is as follows.

Field current (A)	0.5	1.0	1.5	2.0	2.5	3.0	3.5	4.0	5.0	5.5
Generated emf (V)	120	240	360	480	540	600	660	696	738	744

The generator is shunt excited and is driven at 1000 rpm. If its field resistance is 120 Ω , what is its no-load generated voltage? If the load resistance is 5 Ω and the armature resistance is 1 Ω , find the terminal voltage and load current.

[10 marks]

(ii) A 400-V dc shunt motor takes 50 A on full-load, and the speed is then 1000 rev/min. For this full-load condition, the field current is 2 A, and the windage, friction and iron losses amount to 600 W. If the armature resistance is 0.5 Ω calculate the total losses, the efficiency and output torque.

[10 marks]

8.

Assuming no power loss and no magnetic saturation, show that the torque-speed characteristic of a dc series motor reduces to an inverse square relationship. Contrast this with the torque-speed characteristic of the dc shunt motor.

[12 marks]

A dc series motor operates at 750 rpm with a line current of 80 A from a 230-V source. The series field has a total resistance of 0.11 Ω and the armature circuit resistance is 0.14 Ω . Determine the motor speed when the line current is 20 A.

[8 marks]

END OF EE321 EXAMINATION

The University of Zambia

School of Engineering

Department of Electrical & Electronic Engineering

UNIVERSITY EXAMINATIONS - March 1998

EE381

Digital Electronics

TIME : THREE HOURS

ANSWER : FIVE QUESTIONS (EACH QUESTION CARRIES 20 MARKS)

Q1. Minimise the following function using the Karnaugh map method.

$$F = \bar{A}BC + \bar{A}BC + \bar{A}BCD + \bar{A}BCD$$

Draw the circuit diagram for the realisation of this function. Realise the same function using NAND gates only. Realise the same function using NOR gates only.

Q2. (a) Using Boolean algebra, simplify the following expressions:

(i) $F = ABC + \bar{A}\bar{B}(\bar{A}\bar{C})$

(ii) $F = ABC + ABC + \bar{A}BC$

- (b) Using Boolean algebra, show that the two circuits shown in figure 1(a) and figure 1(b) are equivalent.

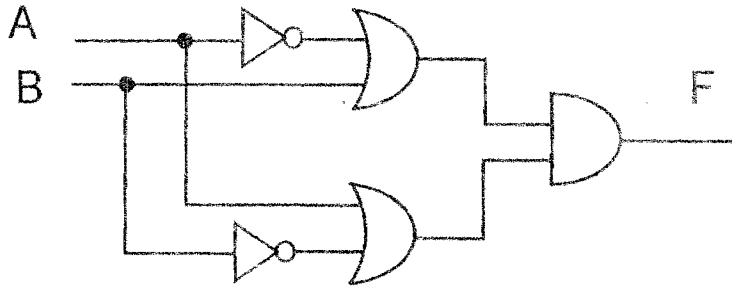

Figure 1 (a)

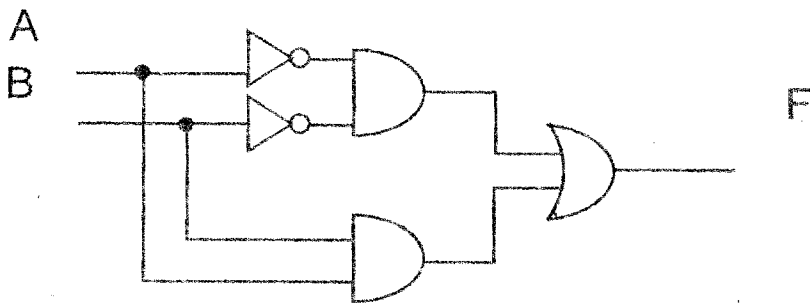

Figure 1 (b)

- (c) Draw the circuit diagram for a full adder and explain its operation.

Q3. Draw the circuit and prepare the truth tables for the flip-flops below. Explain briefly and clearly the truth tables.

- (a) NOR **S-R** flip-flop
- (b) NAND **S-R** flip-flop
- (c) **J-K** flip-flop

- Q4. (a) Design a 3 to 8 decoder
- (b) (i) Express numbers 0 – 15 using the base 3
(ii) Express numbers 0 – 12 using the base 5
- (d) Let X and Y be two-bit binary numbers i.e. $X = x_1x_0$ where x_1 is the most significant bit, and similarly for Y. Design a circuit that should have 1 as the output when $Y \geq X$.

- Q5. Design a **J-K** BCD-Counter which will count according to table 1 as shown below.

Table 1: Counter states and clock pulses

Clock pulses	0	1	2	3	4	5	6	7	8	9	10
X_1	0	0	0	0	0	0	0	0	1	1	0
X_2	0	0	0	0	1	1	1	1	0	0	0
X_3	0	0	1	1	0	0	1	1	0	0	0
X_4	0	1	0	1	0	1	0	1	0	1	0

- Q6. (a) Convert 431_5 to the number system with the base:
- (i) 3 (ii) 8 (iii) 10 (iv) 16
- (b) Convert:
- (i) 92_{10} to quinary (ii) 212_3 to octal
(iii) 716_8 to binary (iv) 314_5 to hexadecimal

Q7. Design a Moore Type non-overlapped bit sequence detector (BSD) using D flip-flops that will have "1" as the output when it has received a sequence "1 1 1". Below is an example of the input and output.

Input	10010111011100111001
Output	00000001000100001000

- Q8. (a) Explain the function of the following:
- (i) Program Counter (PC)
 - (ii) Address Register (AR)
 - (iii) Data Register (DR)
 - (iv) Instruction Decoder (ID)
- (b) Describe procedures involved in both the FETCH and EXECUTE phases when a micro-processor executes the program of adding two numbers.

END OF EXAM

THE UNIVERSITY OF ZAMBIA
School of Engineering, Dept of Electrical & Electronic Eng.
UNIVERSITY EXAMINATION 1997/1998 MARCH 1998
ELECTROMAGNETIC FIELDS EE411
time: 3 HOURS
ANSWER 5 QUESTIONS OUT OF 8
ALL QUESTIONS CARRY 20 POINTS

Question 1.

Given is a parallel plate capacitor.
The distance between the plates is d metre.
The area of both plates is S m² each.
 $\epsilon_0 = 8.85 \times 10^{-12}$ F/m.

- a. Derive the capacitance. (5 points)
- b. Now this capacitor is filled for 50% with a dielectricum having a rel. permittivity ϵ_r . See fig Q1.
Find its capacitance. (15 points)

Question 2.

Given is a vector field $\vec{F} = x\vec{a}_x + xy\vec{a}_y + y\vec{a}_z$
Verify the divergence theorem over a cube one unit on each side.
This cube is situated in the first octant of the Cartesian coordinate system with one corner at the origin as shown in figure Q2.

Question 3.

Find the voltage across each dielectric in the capacitor, shown in figure Q3, when the applied voltage is 100 V.
There is a 3mm layer with relative permittivity 2 and the remaining 5mm space is filled with air.
The parallel conducting plates both have an area of 0.2m².

Question 4.

The electrostatic field intensity \vec{E} is derivable as the negative gradient of a scalar electric potential V ; that is $\vec{E} = -\nabla V$.
Determine \vec{E} (give magnitude and direction) at the point (2,1,1) if $V = V_0 e^{-y} \cos(\pi x)$.

Question 5.

Determine the resistance of the insulation in a length 1 metres of coaxial cable whose cross sectional area is shown in figure Q5.

Assume a current I from the inner conductor (radius a) to the outer conductor (radius b).

See next page for questions 6, 7 and 8.

Question 6.

N turns of wire are wound around a toroidal core of a ferromagnetic material with permeability μ . The core has a mean radius r , a circular cross section of 0.01 m^2 , and a narrow air gap of length l_{gap} as shown in figure Q6.

A steady current I flows in the wire.

Determine:

- the magnetic flux density \vec{B}_f in the ferromagnetic core. (6 points)
- the magnetic field density \vec{H}_f in the core. (6 points)
- the magnetic field density \vec{H}_g in the gap. (8 points)

Question 7.

A piece of straight wire as shown in figure Q7 carries a steady current I Ampere in the positive z direction.

This current causes a magnetic field in point P .

- Using Biot-Savart law, find the general expression for the field contribution $d\vec{H}$ (at point P) that originates from the current section $I d\vec{l}$. (4 points)
- Express $d\vec{H}$ as a function of I , r and α (6 points)
- Find \vec{H} in point P . (6 points)
- This filament is extended to infinity in both directions. Find \vec{H} at point P and check the result with Ampères circuital law. (4 points)

Question 8.

A current filament of 1 Ampere in the \vec{a}_z direction is parallel to the z -axis at $x = 1$ metre and $y = 1$ metre. Refer to figure Q8.

Find the magnetic field intensity \vec{H} in the origin.

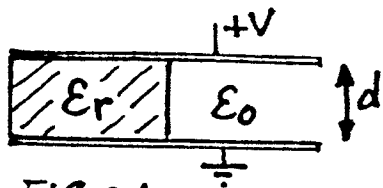

FIG Q1

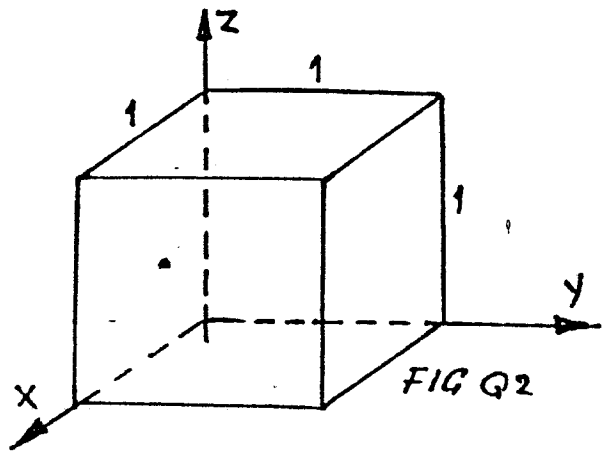

FIG Q2

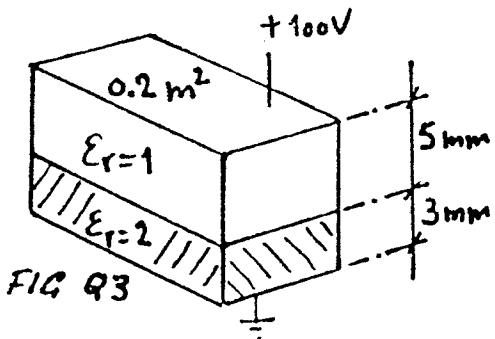

FIG Q3

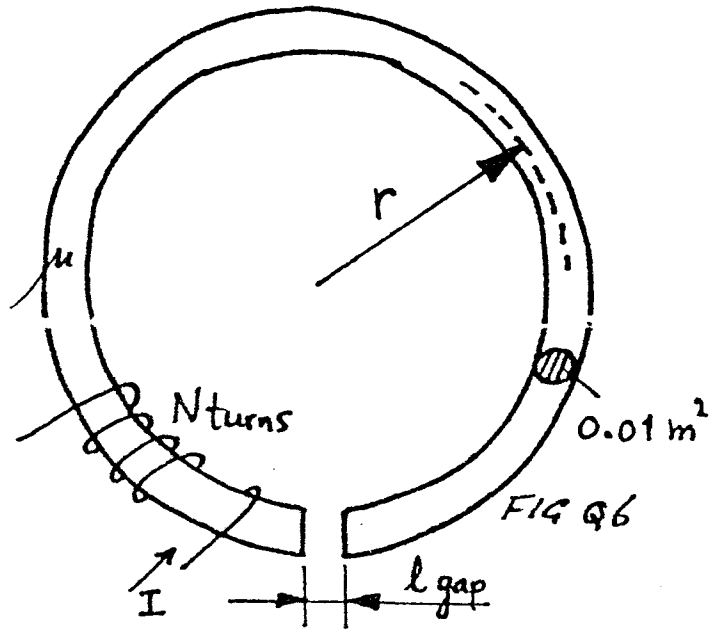

FIG Q6

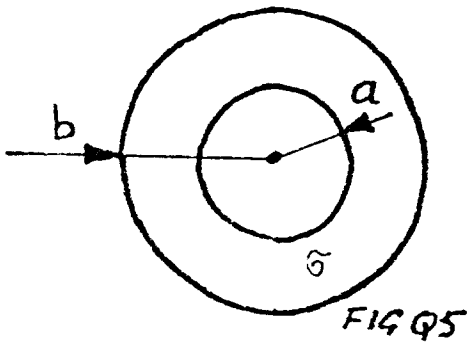

FIG Q5

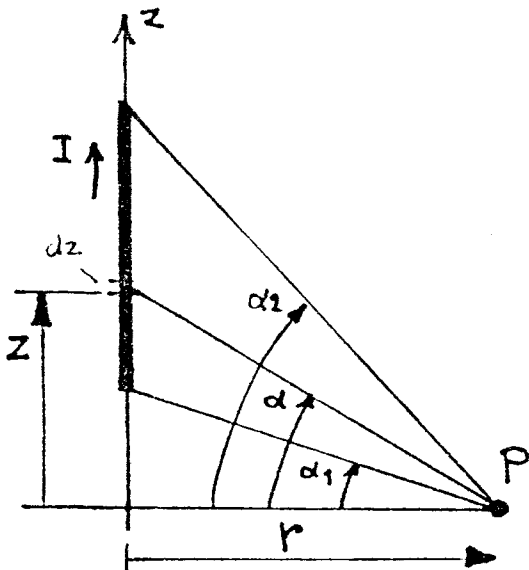

FIG Q7

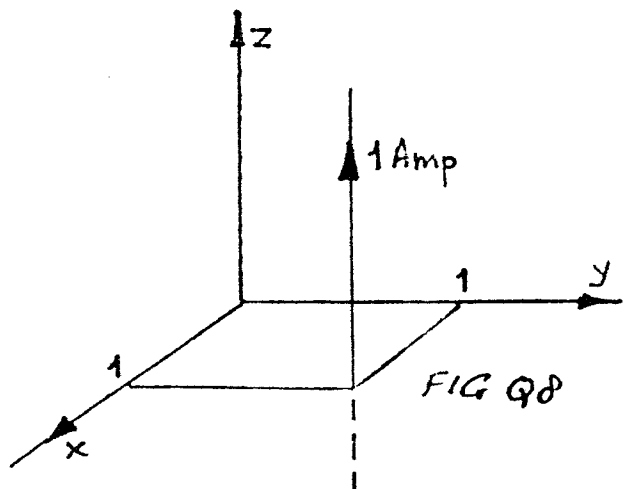

FIG Q8

The University of Zambia

Department of Electrical and Electronic Engineering

University Examination - March, 1998

EE471 Telecommunication I

Time: Three hours

Answer: Five Questions

Permitted Materials

Calculator

Table of Bessel Functions

Smith Chart

Complementary Error Function Table

Question 1 (20 marks)

a) Derive an expression for the overall noise figure for an analog cascade network, as shown below in Fig. 1.1.

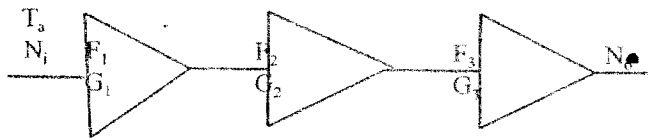

Figure 1.1 An analog cascade network.

b) What is the important relationship between F_1 and G_1 for the network in Fig. 1.1, in terms of noise figure and gain?

c) A receiver front end, shown in Fig. 1.2a, has a noise figure of 10dB, a gain of 80dB, and a bandwidth of 6MHz. The input signal power, S_i , is 10^{-11} W. Assume that the line loss is zero and the antenna temperature is 150K. Find T_R , T_S , N_{out} , $(SNR)_{in}$, and $(SNR)_{out}$.

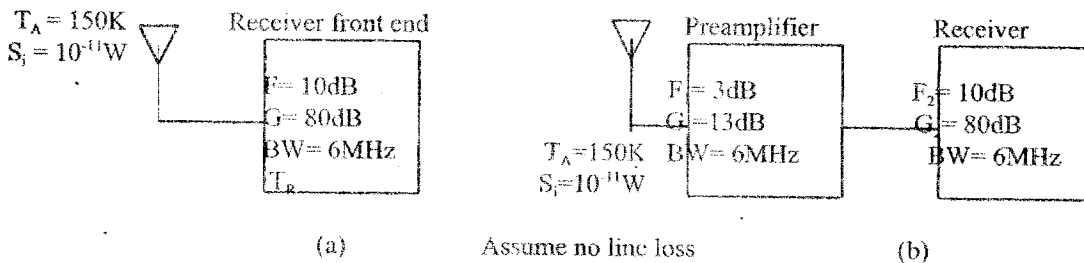

Figure 1.2 Improving a receiver front end with a low-noise preamplifier.

Now a preamplifier, as shown in Fig. 1.2b, is introduced with a noise figure of 3dB, and a bandwidth of 6MHz to improve the SNR of the receiver. Find T_c (composite) for the preamplifier and receiver. Similarly, find T_s , F_c , N_{out} , and $(SNR)_{out}$. Assume zero line loss.

d) A filter has a transfer function as shown below in Fig. 1.3. What is the noise equivalent bandwidth of the filter, for a base-band system. Assume white noise with $PSD = \frac{N_0}{2}$

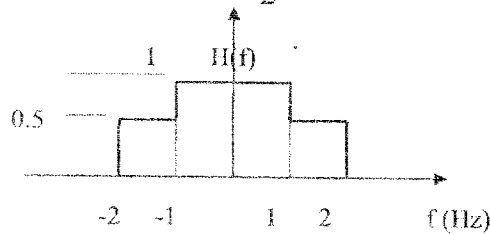

Figure 1.3 Filter transfer function.

Question 2 (20 marks)

a) Find the Fourier series of a sinusoid, $x(t) = A \cos(2\pi t/T)$, with period T , and band-limited to $1/T$ Hz. By exploiting the properties of the Discrete Fourier Transform (DFT), with number of samples, N , being 4.

b) We are given a 4 point digital filter: $x(0) = x(2) = 1$, and $x(1) = x(3) = -1$. Find the DFT for $X(n)$ of the filter and plot its frequency response from π to $-\pi$. The filter frequency response is given by $X(\omega) = \sum_{k=0}^3 x_k e^{-j2\pi nk/N}$

c) Plot the magnitude and phase for the signal, $x(\omega) = j\sin(2\omega)$, from π to $-\pi$.

d) Consider a purely real signal x_k using the definition of the DFT, $X(n) = \sum_{k=0}^{N-1} x_k e^{-j2\pi nk/N}$, with $n = 0, 1, \dots, N-1$. Prove that $|X_1| = |X_{N-1}|$ and the phase $\angle(X_1) = -\angle(X_{N-1})$.

Question3 (20marks)

- a) Verify that the message signal $m(t)$ is recovered from a modulated double side-band suppress carrier (DSBSC) signal by first multiplying it by a local oscillator sinusoid carrier and then passing the resultant signal through a low-pass filter, as shown in Fig. 3.1 below, a.1) in the time domain, a.2) in the frequency domain.

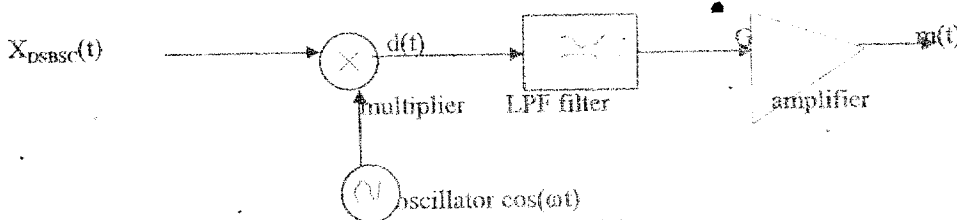

Figure 3.1 A synchronous demodulator.

- b) Sketch an amplitude modulation (AM) diode detector schematic circuit diagram. Include in your diagram the input signal coupling network, and appropriate signals where suitable (input to output stage). What kind of diode would you recommend to be used in the detector, and what is the main factor that affects the efficiency of the detection?
- c) In a square law modulator a carrier $3\cos(2\pi f_c t)$ is added to the message signal $\cos(2\pi f_m t)$, and the sum is passed through a non-linear transistor amplifier with input output voltage relationship $V_{out}(t) = 1 + 0.2V_{in}(t) + 0.1V_{in}^2(t)$. What is the modulation index of the signal emerging from a band-pass filter centred on f_c with bandwidth $2f_m$?
- d) For a single-tone signal, $m(t) = qA\cos(\omega_m t)$, which amplitude-modulates a carrier wave, $A\cos(\omega_c t)$. Show that the maximum efficiency, η , of the total sideband power to the total signal power in AM-FC modulation is 33.3%.

Question 4 (20 marks)

- a) Describe, with the aid of a schematic circuit diagram and phasor diagram, the operation of a Foster-Seeley frequency discriminator. What is the purpose of the RF choke in your schematic diagram?
- b) An oscillator operating at 100MHz has a 75pF capacitor in its tuning circuit. What total capacitance swing must the varactor supply to allow the modulator to have 80KHz peak frequency deviation?
- c) A 10V, 100MHz carrier wave is frequency modulated by a 2KHz tone when the frequency deviation is 1KHz. Calculate the amplitude of the first-order, and second-order frequencies.
- d) An FM modulator has a frequency deviation constant K_f of 5Hz/V. The modulator has input $m(t) = 4\cos(2\pi t)$:
- What is the modulation index?
 - Is this narrow band FM? why?
 - If the same $m(t)$ is used for a phase modulator (PM), what must the phase deviation constant, K_p , be to yield the modulation index determine in i) above?

Question 5 (20 marks)

- a) Explain in your own words:
- why sampling give rise to a PAM waveform, support your answer with the aid of diagrams,
 - why a PPM signal is more resistant to noise than a PAM signal. What type of noise does PPM likely to experience?
- b) In a PAM system there are N base-band signals, $\cos(2000\pi t)$, $\cos(3500\pi t)$, and $\cos(6000\pi t)$.
- What should be the sampling rate required for the N original signals to be reconstructed at the receiver?
 - What is the channel bandwidth?
- c) Draw a block diagram for a PCM system, including transmitter, communication link, and receiver.
- d) Twenty-four voice signals are to be transmitted via multiplexed PAM with a marker pulse for frame synchronization. The sampling frequency is 8KHz and the TDM signal has a 50% duty cycle. Calculate the signaling rate, pulse duration, and minimum transmission bandwidth.
- e) The information in an analog waveform, with maximum frequency, $f_m = 3\text{KHz}$, is to be transmitted over an M-level PCM system, where the number of pulse levels is $M = 16$. The quantization distortion is specified not to exceed $\pm 1\%$ of the peak-to-peak analog signal.

Question 5 continue.

- what is the minimum number of bits/sample, or bits/PCM word that should be used in the PCM system?
- what is the minimum required sampling rate, and what is the resulting bit transmission rate?
- what is the PCM pulse or symbol transmission rate.

Question 6 (20 marks)

a) Define the following set of terms, with appropriate diagram and equation where necessary:

- Orthogonal signal set,
- Orthonormal set,
- Antipodal signal space, and
- Coherent detection

b)

- Show that the three functions illustrated in Fig. 6.1 are pairwise orthogonal over the interval $(-2, 2)$.
- Determine the value of the constant, A , that makes the set of functions in part (i) above an orthonormal set.
- Express the following waveform, $x(t)$, in terms of the orthonormal set of part (ii).

$$X(t) = \begin{cases} 1 & \text{for } 0 \leq t \leq 2 \\ 0 & \text{otherwise} \end{cases}$$

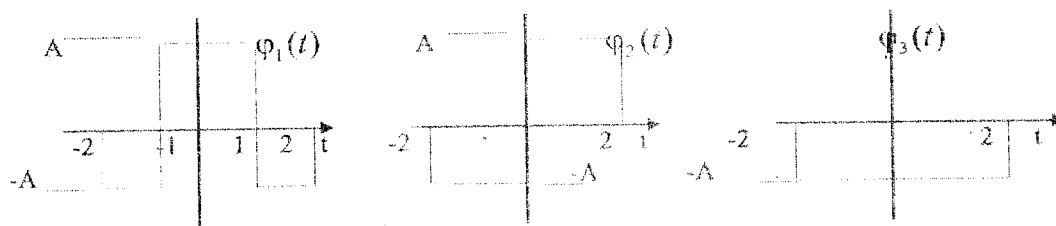

Figure 6.1 A set of waveform to test for orthogonal and orthonormal properties.

- Find the bit error probability for a BPSK system with a bit rate of 1Mbits/sec. The received waveforms, $s_1(t) = A\cos(\omega_c t)$, $s_2(t) = -A\cos(\omega_c t)$, are coherently detected with a match filter. The value of A is 10mV. Assume that the single sided noise power spectral density is $N_0 = 10^{-11}$ W/Hz and that signal power and energy per bit are normalized relative to 1Ω resistive load.
- Sketch a binary correlator receiver, using two correlator, with reference signal $S_i(t)$. If a system's main performance criterion is bit error probability, which of the following two modulation schemes would be selected for an additive white gaussian noise (AWGN) channel? Show computations.
Binary coherent orthogonal FSK with $E_b/N_0 = 12$ dB.
Binary noncoherent orthogonal FSK with $E_b/N_0 = 14$ dB.

Question 7 (20 marks)

- A high-frequency transmission line of negligible loss has a characteristic impedance of 600Ω and is terminated by an antenna. Calculate the standing wave ratio along the line when the antenna impedance is:
 - 500Ω,
 - $400 + j300 \Omega$
- For the following line length determine the input line impedance, Z_i in terms of characteristic line impedance, Z_0 , and terminating load impedance, Z_L .
 - Short circuit line termination,
 - Quarter wave transformer ($\lambda/4$),
 - Matched line,
 - Without the aid of the Smith Chart, what is the reflection coefficient, Γ , looking into a load of impedance, $Z_L = 75\Omega$, with a line of characteristic impedance, $Z_0 = 83\Omega$.

Question 7 continue.

- c) A 50Ω transmission line is connected to a load, a double stub eight of a wavelength ($\lambda/8$) apart, is used to match the load to the line, as shown in Fig. 6.1. Find the required lengths of the short-circuited stubs. Note submit your Smith chart with your solution!

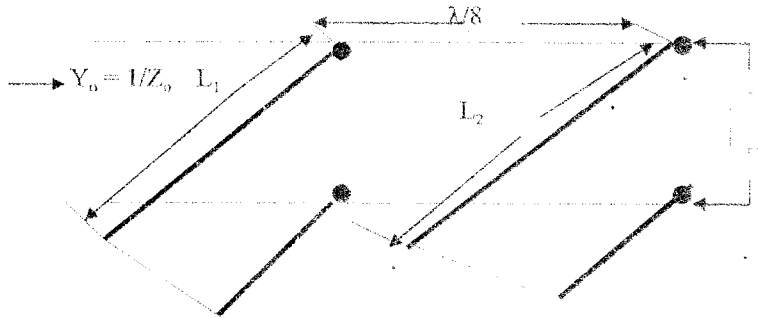

Figure 6.1 Double stub transmission line matching (short circuited stubs).

Question 8 (20 marks)

- a) With the aid of diagram or equation, state what you understand by the following terms:

- i) dynamic range of a receiver,
- ii) reciprocal mixing,
- iii) total harmonic distortion, and
- iv) intermediate frequency.

- b) An-FET has a perfect square-law characteristic - $I_D = I_{DSS}(1 - V_{gs}/V_p)^2$ - resulting in a transfer function:

$V_o = A_0 + A_1 V_i + A_2 V_i^2$. Which of the following effects may be observed in this FET amplifier, and state reason for your choice:

- i) second harmonic distortion,
- ii) third harmonic distortion,
- iii) gain compression,
- iv) third-order intermodulation.

- c) For an amplifier with a 10dB noise figure and desired signal-to-noise ratio of 160dB in 1Hz bandwidth, determine the lowest power level that would give rise to a detectable output signal power. An oscillator with the following specification: amplifier gain = 10dB, output power = 10dBm, frequency = 50MHz, with resonant Q factor, $Q = 100$, noise figure = 10dB at ambient temperature 27°C . Calculate the noise floor and sketch the curve.

Fundamental Constants

Boltzmann's Constant	$K = 1.38 \times 10^{-23}$
Velocity of light in free space	$c = 2.997 \times 10^8$ m/s
Charge on the electron	$q = 1.6 \times 10^{-19}$ C

$$\text{Noise Figure} = \frac{\text{input}(S/N)\text{ratio}}{\text{output}(S/N)\text{ratio}}$$

Noise Figure of cascade amplifiers (Friis formula):

$$F_{\text{total}} = F_1 + \frac{F_2 - 1}{G_1} + \frac{F_3 - 1}{G_1 G_2}$$

Noise:

Thermal	$\overline{V_n^2} = 4KTRB$	$\overline{i_n^2} = 4KTBR$
---------	----------------------------	----------------------------

Shot	$\overline{i_n^2} = 2qIB$
------	---------------------------

Flicker	$\overline{i_n^2} = \frac{K(I_{DC})^a B}{f_b}$
---------	--

Power Transfer:

Maximum power delivered to matched load $V^2/4R$

Linear Modulation:

$$\text{modulation index } q = \frac{V_{\text{max}} - V_{\text{min}}}{V_{\text{max}} + V_{\text{min}}}$$

power efficiency $\eta = (\text{power in side tone})/(\text{power in total})$

Angular Modulation:

instantaneous phase $\phi(t)$

PM $k_p m(t)$, FM $2\pi k_f \int m(\lambda) d\lambda$

Transmission lines:

$$Z_i = Z_0 \left[\frac{Z_l \cos \beta \ell + jZ_0 \sin \beta \ell}{Z_0 \cos \beta \ell + jZ_l \sin \beta \ell} \right]$$

$$\text{SWR} = \frac{1 + |\Gamma|}{1 - |\Gamma|}$$

For loss-less line $Z_0 = \sqrt{\frac{L}{C}}$

Trigonometric Identity:

$$\sin(a) + \sin(b) = 2 \sin[(a+b)/2] \cos[(a-b)/2]$$

$$\cos^2(a) = [1 + \cos(2a)]/2$$

$$\cos(\theta) = (e^{j\theta} + e^{-j\theta})/2$$

TABLE
FM Side Frequencies from Bessel Functions

n or Order

x (β)	J_0	J_1	J_2	J_3	J_4	J_5	J_6	J_7	J_8	J_9	J_{10}	J_{11}	J_{12}	J_{13}	J_{14}	J
0.00	1.00	—	—	—	—	—	—	—	—	—	—	—	—	—	—	—
0.25	0.98	0.12	—	—	—	—	—	—	—	—	—	—	—	—	—	—
0.5	0.94	0.24	0.03	—	—	—	—	—	—	—	—	—	—	—	—	—
1.0	0.77	0.44	0.11	0.02	—	—	—	—	—	—	—	—	—	—	—	—
1.5	0.51	0.56	0.23	0.06	0.01	—	—	—	—	—	—	—	—	—	—	—
2.0	0.22	0.58	0.35	0.13	0.03	—	—	—	—	—	—	—	—	—	—	—
2.5	-0.05	0.50	0.45	0.22	0.07	0.02	—	—	—	—	—	—	—	—	—	—
3.0	-0.26	0.34	0.49	0.31	0.13	0.04	0.01	—	—	—	—	—	—	—	—	—
4.0	-0.40	-0.07	0.36	0.43	0.28	0.13	0.05	0.02	—	—	—	—	—	—	—	—
5.0	-0.18	-0.33	0.05	0.36	0.39	0.26	0.13	0.05	0.02	—	—	—	—	—	—	—
6.0	0.15	-0.28	-0.24	0.11	0.36	0.36	0.25	0.13	0.06	0.02	—	—	—	—	—	—
7.0	0.30	0.00	-0.30	-0.17	0.16	0.35	0.34	0.23	0.13	0.06	0.02	—	—	—	—	—
8.0	0.17	0.23	-0.11	-0.29	-0.10	0.19	0.34	0.32	0.22	0.13	0.06	0.03	—	—	—	—
9.0	-0.09	0.24	0.14	-0.18	-0.27	-0.06	0.20	0.33	0.30	0.21	0.12	0.06	0.03	0.01	—	—
10.0	-0.25	0.04	0.25	0.06	-0.22	-0.23	-0.01	0.22	0.31	0.29	0.20	0.12	0.06	0.03	0.01	—
12.0	0.05	-0.22	-0.08	0.20	0.18	-0.07	-0.24	-0.17	0.05	0.23	0.30	0.27	0.20	0.12	0.07	0.01
15.0	-0.01	0.21	0.04	-0.19	-0.12	0.13	0.21	0.03	-0.17	-0.22	-0.09	0.10	0.24	0.28	0.25	0.01

IMPEDANCE OR ADMITTANCE COORDINATES

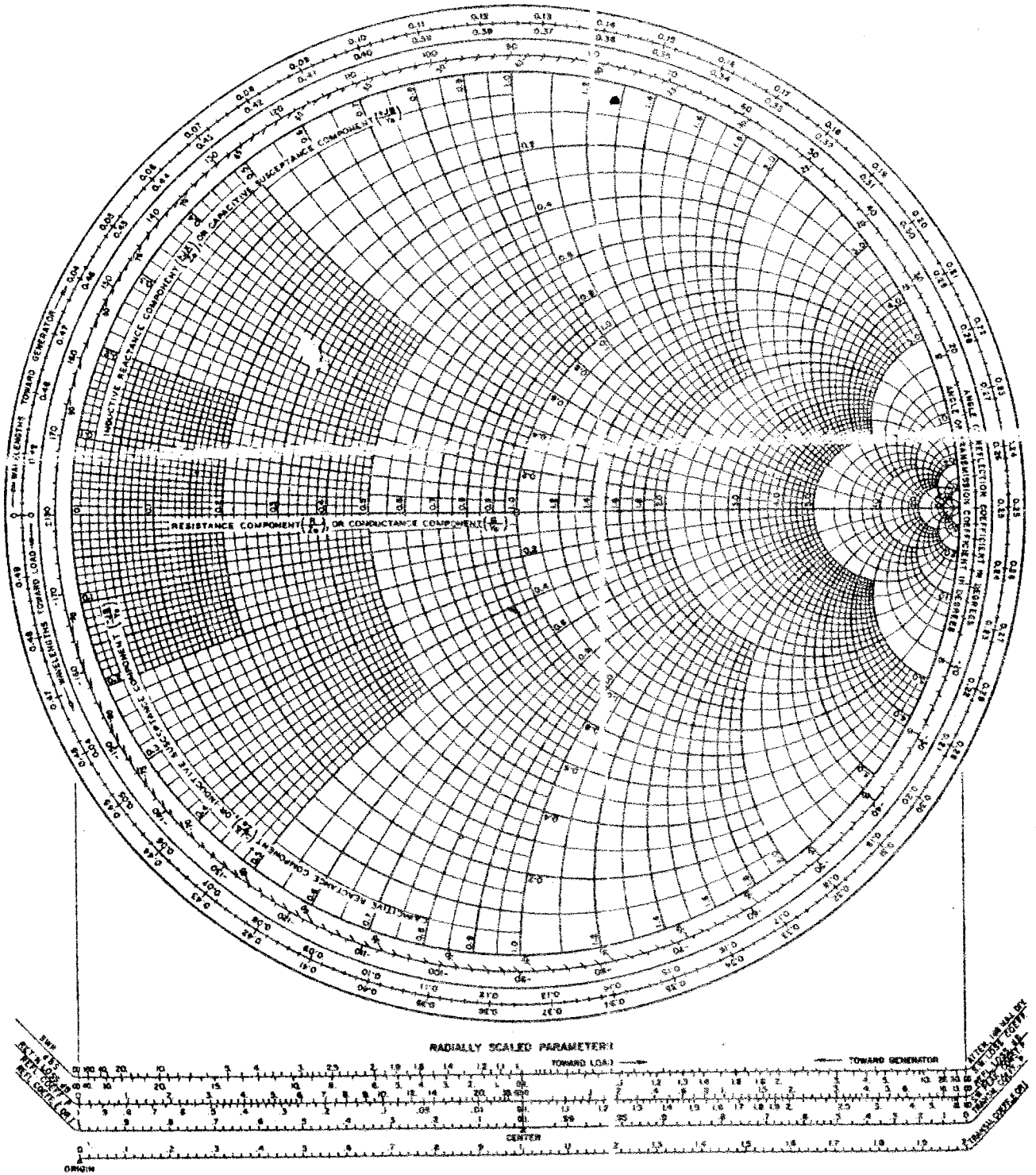

Fig. 8.6. SMITH CHART (1966) with transmission coefficient scales (see Chart A in cover envelope).



THE UNIVERSITY OF ZAMBIA
DEPARTMENT OF ELECTRICAL AND ELECTRONIC ENGINEERING
COMPUTER ENGINEERING
EE481

UNIVERSITY EXAMINATIONS, MARCH 1998.

TIME : 3 HOURS

ANSWER : Five QUESTION

: ALL QUESTIONS CARRY EQUAL MARKS.

- Q1.**
- a) How would you classify microprocessors? [2]
 - b) Draw the programmer's model for the Intel 8086 processor and describe the functions of all the registers and their applications [9]
 - c) Describe (with examples) the different addressing modes used in an Intel 8086 processor. In each case, show (if any) the segment involved [9]
- Q2.**
- Linked lists, stacks and queues are among dynamic data structures that grow and shrink at execution time
- a) Define a self-referential structure and explain how it is used in connection with dynamic data structures. [3]
 - b) Describe the basic operations of linked lists, stacks and queues. [10]
 - c) With the help of self-referential nodes, explain how an addition is done to a linked list, stack and queue. [7]
- Q3.**
- a) Outline the steps required in designing a memory system. [3]
 - b) What are two advantages gained in using partial-address decoding? Name two disadvantages [2]
 - c) Design a fully decoded 56K RAM and an 8K EPROM memory system using SRAM (6164) and EPROM (2764) shown in Appendix B. Use the 74LS138 and assume EPROM is at base address of 00000H. Show the connection of the memory system to the 8088 processor. Draw the memory map of the system. [15]

- Q4**
- a) Discuss the difference between the following I/O channels:
- PC Bus; ISA Bus; EISA Bus; MCA Bus; PCI Bus. [6]
 - b) With the help of the 8086 bus cycle, describe the use of wait states and show how they relate to the system's bus cycle? [3]
 - c) Prove that the figure shown in Appendix C will insert two wait states [11]

Q5. Apply the process of software development to the following design problem. [20]
Design a PC-based control system for a road junction with a single traffic light and a pedestrian crossing. The sequence and timing of each of the individual lights is outlined in the table below.

The traffic light has a pedestrian button which when activated causes the normal sequence to be interrupted and the traffic lights goes RED in a safe manner (i.e. if the button is pressed when a sequence is at RED/AMBER, then the system should follow the normal sequence until it gets back to the RED only then should the pedestrian light become active). A WALK (W) light will be active when pedestrians are allowed to cross the road. This should stay active for four seconds, followed by flashing WALK (W) light for another four seconds (note: flashing on/off is spaced one second apart). When this goes OFF a DON'T WALK light should be ON. Other system specifications are as follows

- (i) The pedestrian button is a push button type and may only be pressed for a short time. It can also be pressed at any time in the sequence. The minimum time for a button press is 0.5 seconds.
- (ii) The system should act in a predictable manner, that is, RED/AMBER must always follow RED, GREEN must follow RED/AMBER, AMBER follows GREEN, and RED follows AMBER. The sequence timing is not affected by the pedestrian switch status.
- (iii) For safety, the DON'T WALK light should always be on when the AMBER or GREEN lights are on and the WALK should only be on when the RED light is on.

Traffic Table Sequence.

<i>Sequence No.</i>	<i>Sequence</i>	<i>Timing (seconds)</i>
1	RED	6
2	RED/AMBER	1
3	GREEN	4
4	AMBER	2
1	RED	6
2	RED/AMBER	1
etc		

Hints: Use the PC-Labcard port 230H and 8255 chip, ports A (push button) and port B (for traffic lights). Make the connections and write a C program that performs the task

- Q.6** In a communication application, the 8251 is connected to the 8259. The TXC and RXC of the 8251 are both connected to a clock at 76.800 kHz and the CLK is at 8 MHz. The TXRDY and RXRDY of the 8251 are connected to the 8259's IR0 and IR1 respectively. When a character is transmitted, IR0 is active due to TXRDY and similarly, on reception IR1 is active due to RXRDY. The 8251 is decoded at base port address of 40H and the 8259 at base port address of 44H. The interrupt service routine (ISR) for character transmission and reception are at 18000H and 28000H respectively. (Refer to Appendix A and B).
- a) Use the NAND gate in to decode the PIC and USART [3]
- b) If the mode instruction to the 8251 is DEH, what is the baud rate for both transmit and receive? [2]
- c) The 8259 is programmed to operate as:
- single master; edge-sensitive; ICW4 required; base interrupt vector 40H; no specific full-nested mode; no buffered mode; AEOI mode enabled.
 Program the 8259 and discuss the sequence of events from the time a character is received by the 8251 to the time the ISR finishes processing the character. [15]
- Q7.** Write a C program that implements a scientific calculator functions: ADD, SUB, MULT, DIV, SIN, COS, TAN, NOT, AND and OR. Each of these function are implemented as a separate function. Use a simple menu for user selections of operation and print result on the screen. [20]
- Q8.** a) What are casts as used in C? [1]
 b) Describe the variable lifetimes and scopes as used in C? [6]
 c) (Given the following declaration:

```
typedef struct Air {
    char * name;
    int seat_number;
    char smoking_or_nonsmoking;
} Airdata;
```

 Explain the meaning of the following declarations:

```
Airdata Personal_Data[10];
Airdata * Personal_Data[10];
Airdata (*Personal_Data)[10];
```

 [6]
- d) Describe the memory models implementation in C and state with reasons the memory model used for *far pointers*. [7]

END OF EE481 EXAMINATIONS MARCH 1998

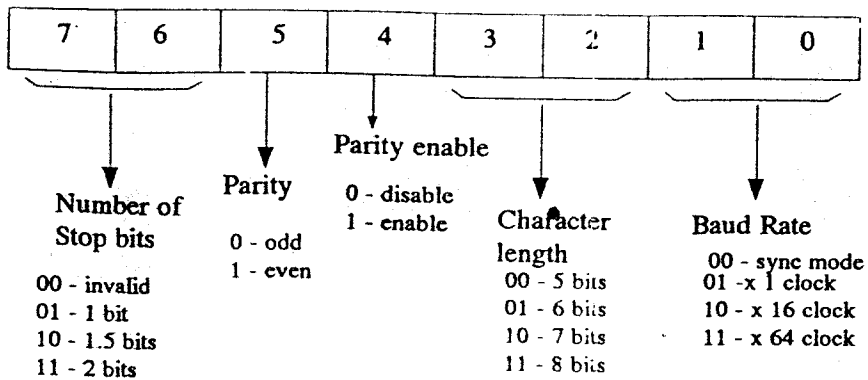

8251 Mode instruction format.

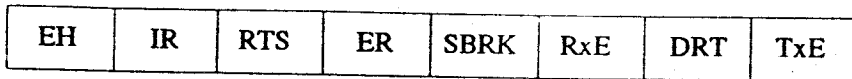

8251 Command instruction format

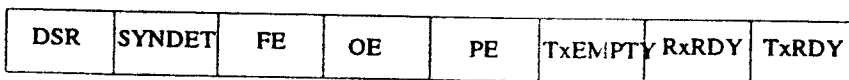

8251 Status byte

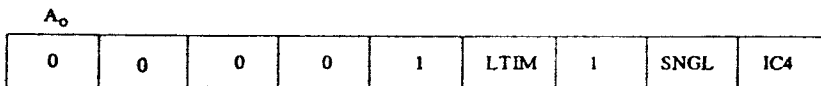

8259 Initialisation Command Word 1

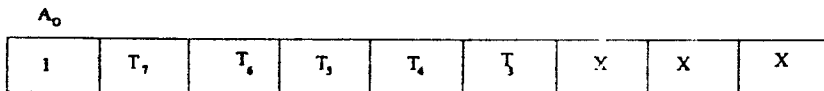

8259 Initialisation Command Word 2

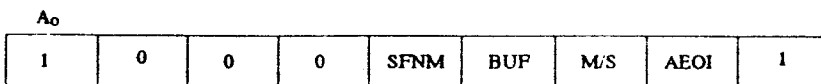

8259 Initialisation Command Word 4

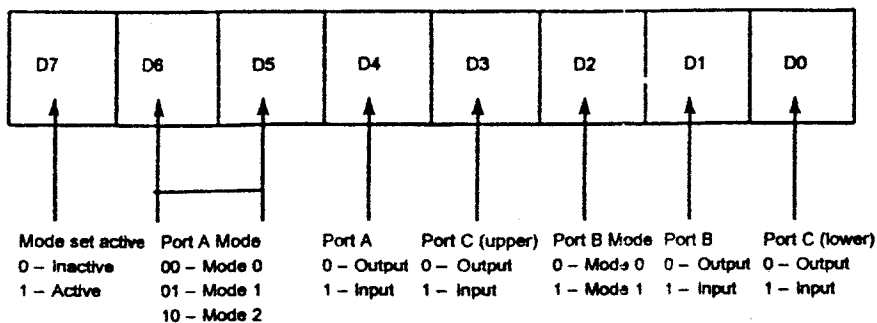

8255 mode word format

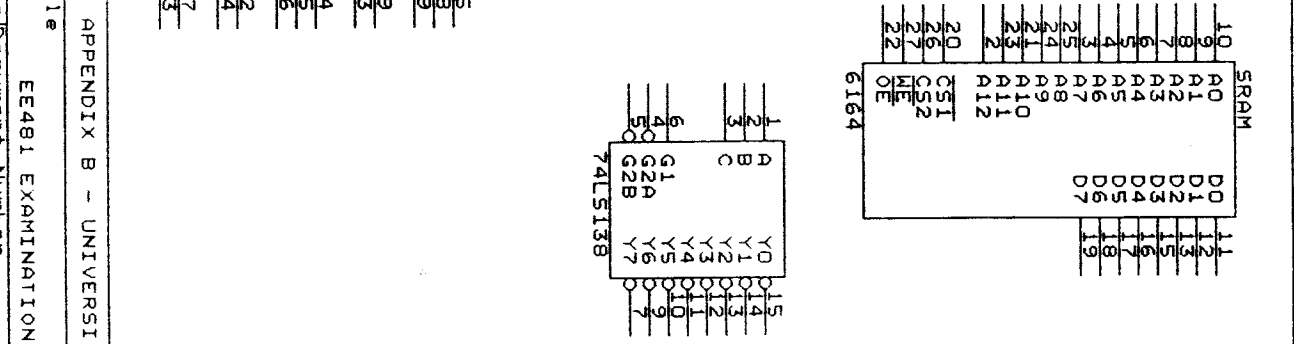
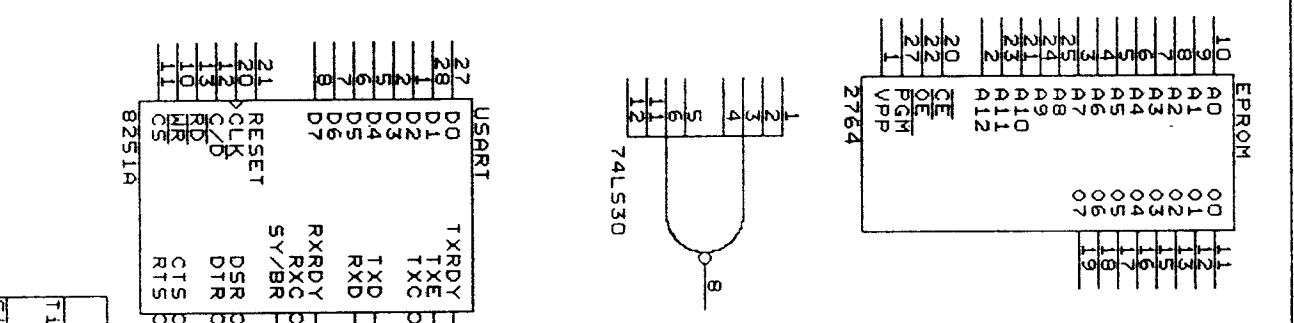
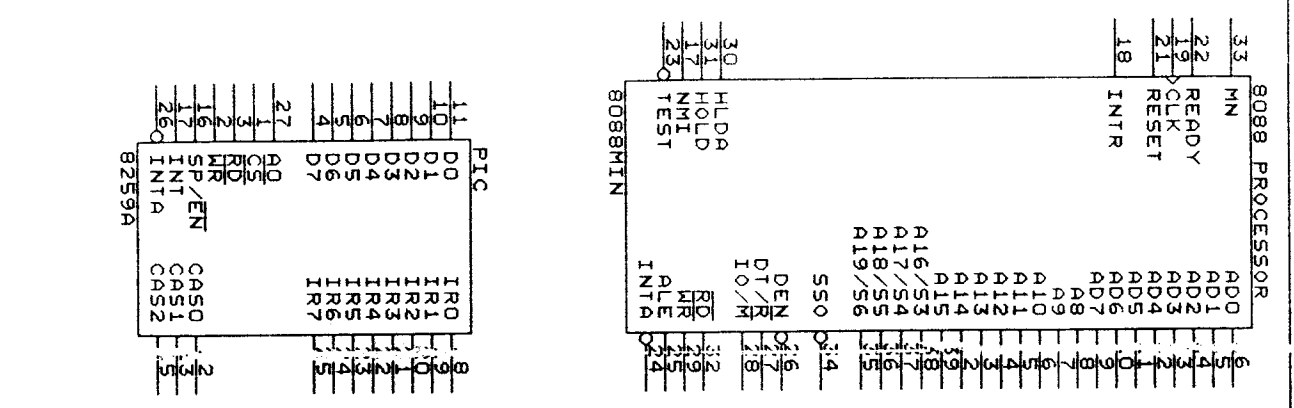
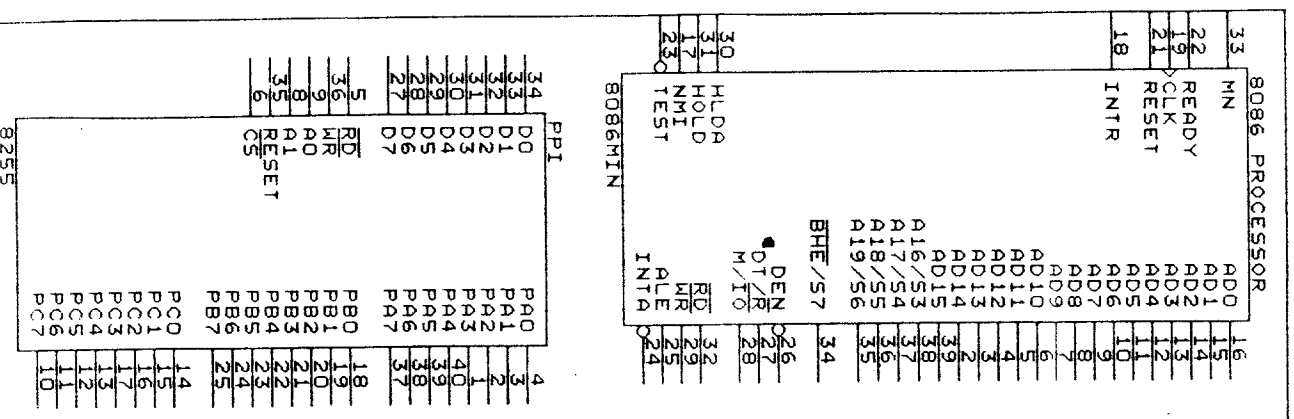

Signal	Pin	Signal	Pin
ADD0	16	ADD1	17
ADD2	18	ADD3	19
ADD4	20	ADD5	21
ADD6	22	ADD7	23
ADD8	24	ADD9	25
ADD10	26	ADD11	27
ADD12	28	ADD13	29
ADD14	30	ADD15	31
ADD16	32	ADD17	33
ADD18	34	ADD19	35
ADD20	36	ADD21	37
ADD22	38	ADD23	39
ADD24	40	ADD25	41
ADD26	42	ADD27	43
ADD28	44	ADD29	45
ADD30	46	ADD31	47
ADD32	48	ADD33	49
ADD34	50	ADD35	51
ADD36	52	ADD37	53
ADD38	54	ADD39	55
ADD40	56	ADD41	57
ADD42	58	ADD43	59
ADD44	60	ADD45	61
ADD46	62	ADD47	63
ADD48	64	ADD49	65
ADD50	66	ADD51	67
ADD52	68	ADD53	69
ADD54	70	ADD55	71
ADD56	72	ADD57	73
ADD58	74	ADD59	75
ADD60	76	ADD61	77
ADD62	78	ADD63	79
ADD64	80	ADD65	81
ADD66	82	ADD67	83
ADD68	84	ADD69	85
ADD70	86	ADD71	87
ADD72	88	ADD73	89
ADD74	90	ADD75	91
ADD76	92	ADD77	93
ADD78	94	ADD79	95
ADD80	96	ADD81	97
ADD82	98	ADD83	99
ADD84	100	ADD85	101
ADD86	102	ADD87	103
ADD88	104	ADD89	105
ADD90	106	ADD91	107
ADD92	108	ADD93	109
ADD94	110	ADD95	111
ADD96	112	ADD97	113
ADD98	114	ADD99	115
ADD100	116	ADD101	117
ADD102	118	ADD103	119
ADD104	120	ADD105	121
ADD106	122	ADD107	123
ADD108	124	ADD109	125
ADD110	126	ADD111	127
ADD112	128	ADD113	129
ADD114	130	ADD115	131
ADD116	132	ADD117	133
ADD118	134	ADD119	135
ADD120	136	ADD121	137
ADD122	138	ADD123	139
ADD124	140	ADD125	141
ADD126	142	ADD127	143
ADD128	144	ADD129	145
ADD130	146	ADD131	147
ADD132	148	ADD133	149
ADD134	150	ADD135	151
ADD136	152	ADD137	153
ADD138	154	ADD139	155
ADD140	156	ADD141	157
ADD142	158	ADD143	159
ADD144	160	ADD145	161
ADD146	162	ADD147	163
ADD148	164	ADD149	165
ADD150	166	ADD151	167
ADD152	168	ADD153	169
ADD154	170	ADD155	171
ADD156	172	ADD157	173
ADD158	174	ADD159	175
ADD160	176	ADD161	177
ADD162	178	ADD163	179
ADD164	180	ADD165	181
ADD166	182	ADD167	183
ADD168	184	ADD169	185
ADD170	186	ADD171	187
ADD172	188	ADD173	189
ADD174	190	ADD175	191
ADD176	192	ADD177	193
ADD178	194	ADD179	195
ADD180	196	ADD181	197
ADD182	198	ADD183	199
ADD184	200	ADD185	201
ADD186	202	ADD187	203
ADD188	204	ADD189	205
ADD190	206	ADD191	207
ADD192	208	ADD193	209
ADD194	210	ADD195	211
ADD196	212	ADD197	213
ADD198	214	ADD199	215
ADD200	216	ADD201	217
ADD202	218	ADD203	219
ADD204	220	ADD205	221
ADD206	222	ADD207	223
ADD208	224	ADD209	225
ADD210	226	ADD211	227
ADD212	228	ADD213	229
ADD214	230	ADD215	231
ADD216	232	ADD217	233
ADD218	234	ADD219	235
ADD220	236	ADD221	237
ADD222	238	ADD223	239
ADD224	240	ADD225	241
ADD226	242	ADD227	243
ADD228	244	ADD229	245
ADD230	246	ADD231	247
ADD232	248	ADD233	249
ADD234	250	ADD235	251
ADD236	252	ADD237	253
ADD238	254	ADD239	255

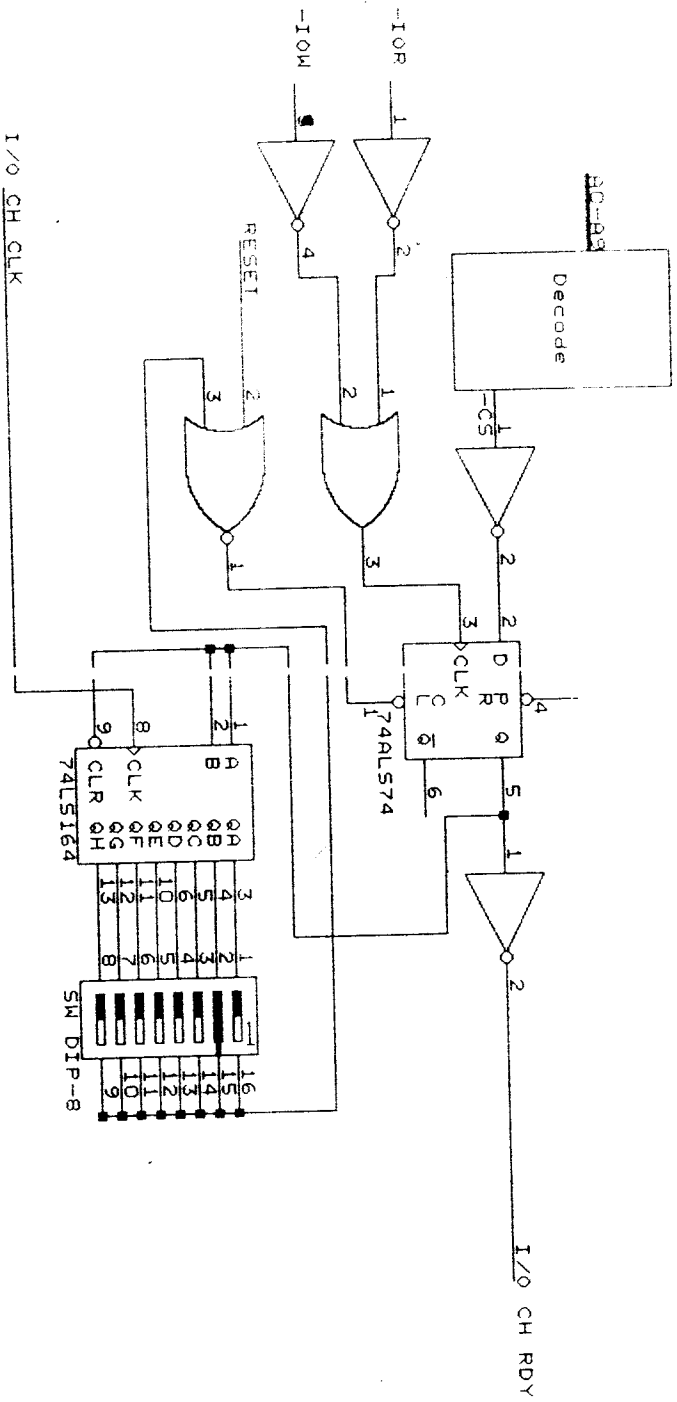

APPENDIX C - UNIVERSITY EXAMINATIONS

Title

E481 EXAMINATIONS MARCH 1998

Size Document Number

A

1

REV

Date: February 7, 1998 Sheet of

UNIVERSITY OF ZAMBIA

School of Engineering Department of Electrical and Electronic Engineering

Examination: Electronic Engineering EE541

Answer any five questions

Time allowed: Three Hours

Question 1

A clock generator, implemented as a synchronous sequential circuit, is required to produce two continuous non-overlapping clock signals as shown in Figure Q1. The numbers shown in the diagram indicate durations in multiples of the input clock period.

Design a circuit which implements this function using D-type edge-triggered flip-flops as the memory elements.

Your design must guarantee glitch-free outputs and, ignoring transient output errors, must start correctly under all circumstances without the use of an external reset signal.

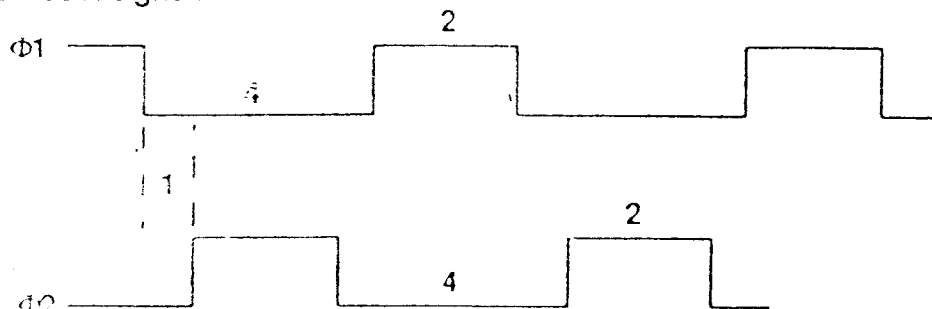

Figure Q1.

Question 2

The outputs of a 4 bit BCD counter are to be displayed on a 7-segment display. Implement the required logic in the following three separate ways:

- using the minimum number of NAND gates.
- using the minimum number of 8-to-1 multiplexers.
- using one PAL device.

Question 3

a) Describe the problems of static and dynamic hazards in combinational logic and show how they can be avoided. Explain why these problems do not usually cause undesirable consequences in synchronous circuits.

b) consider the following flow table for an asynchronous machine:

Present state AB	Next state PQ (inputs)			
	00	01	11	10
00	①	8	-	7
01	2	⑧	⑥	③
11	1	⑤	④	3
10	②	5	6	⑦

Identify the critical races in this table.

Suggest a self-clocked architecture for the implementation of this machine, using edge-triggered D-type flip-flops, to overcome race and hazard problems.

Question 4

Explain the principle of operation of a successive approximation analogue-to-digital (A/D) converter.

Draw the detailed circuitry, using conventional integrated circuit components, for a 4 bit successive approximation A/D converter to convert voltages up to 15 volts. Explain its operation and discuss the errors involved.

Compare the maximum conversion times of a 10 bit digital ramp A/D converter and a 10 bit successive approximation A/D converter if both utilize a 1 MHz clock frequency.

Question 5

Consider the following Algorithmic State Machine (ASM) chart:

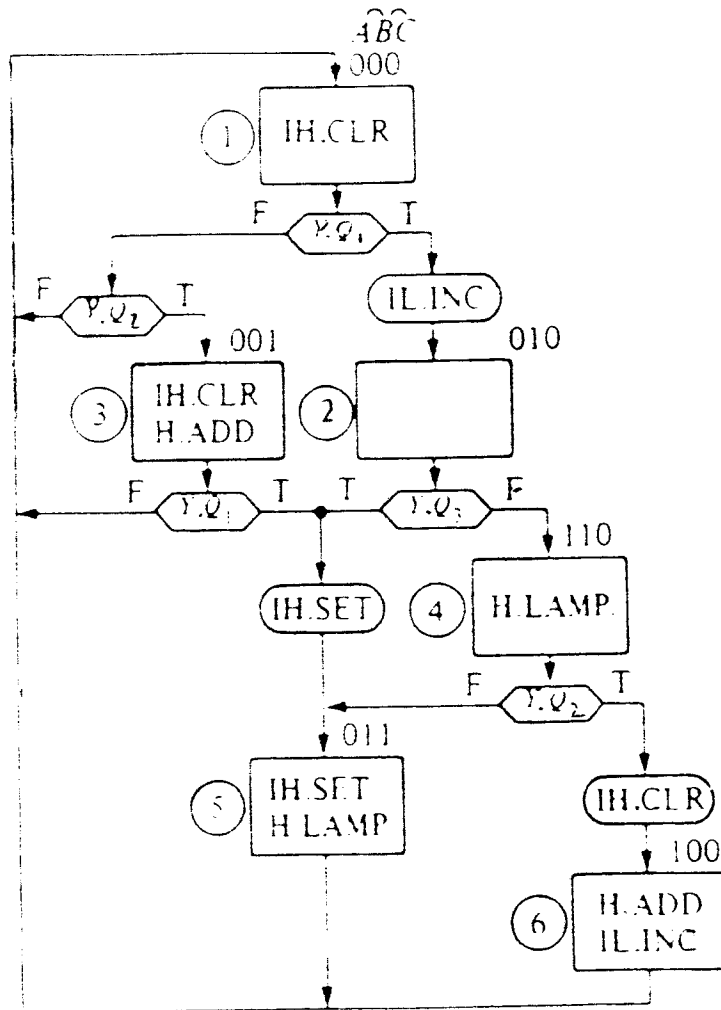

Derive the combined state and output table for the implementation of this ASM chart. Derive the minimized output and excitation functions for implementation by J-K flip-flops, using inputs as map-entered variables.

Question 6

- a) Describe the architecture of Field Programmable Logic Sequencer (FPLS) devices and explain their application in the design of Finite State Machines.
- b) Explain how the architecture of Logic Cell Arrays can be exploited to implement synchronous state machines directly from their ASM charts using one-hot state assignment.

Question 7

Some programmable logic devices contain flip-flops which are wired as shown below:

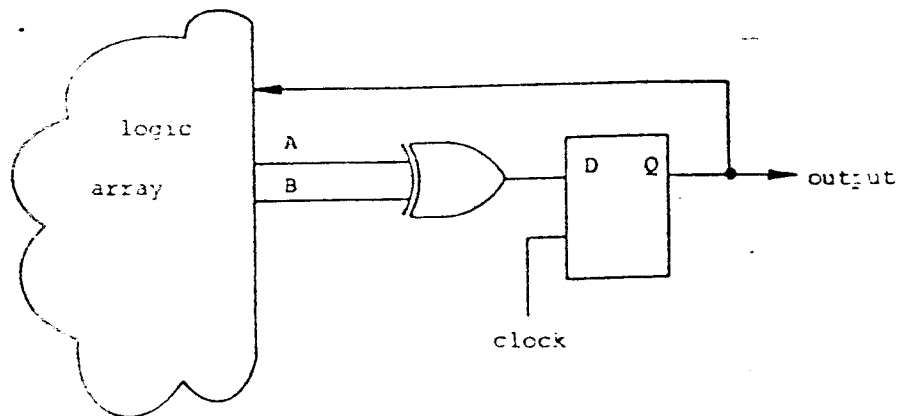

Show how signals A and B can be defined such that the flip-flop appears to be of J-K type. (First look at how it can be converted to the T type.) What are the advantages of J-K flip-flops when used in state machine applications?

Question 8

Explain the fundamental difference between the Reed-Muller algebraic description and Boolean algebra.

Find the Reed-Muller expansion of the following Boolean switching function:

$$f = \bar{x}_4 \bar{x}_3 \bar{x}_2 x_1 + \bar{x}_4 \bar{x}_3 x_2 \bar{x}_1 + x_3 \bar{x}_2 \bar{x}_1 + x_4 \bar{x}_2 \bar{x}_1 + x_3 x_2 x_1 + x_4 x_2 x_1$$

THE UNIVERSITY OF ZAMBIA

SCHOOL OF ENGINEERING

UNIVERSITY EXAMINATIONS- FEBRUARY 1998

EG 279 - INTRODUCTION TO COMPUTING

TIME: THREE HOURS

INSTRUCTIONS: ANSWER ANY FIVE (5) QUESTIONS.

QUESTION ONE:

- A) Using a diagram, illustrate the units that make up a basic digital computer. Explain the function of each unit.
- B) What are the various types of software that can be used on a computer system? Give examples and explain the role each of them plays.
- C) The transfer rate between the CPU and its associated memory is orders of magnitude higher than the mechanical Input/Output transfer rate:
- i) How would this imbalance cause inefficiencies in the effective utilisation of a computer system?
- ii) State and explain any two (2) methods that are used to try and solve these inefficiencies.
- D) i) A student speculated on building a computer to be equipped with 262,144 bytes of Memory but this surprised his classmates who wondered why he thought of such a peculiar number instead of an easy-to-remember number such as 250,000. Justify his choice of 262,144.
- ii) Explain the following types of memory and state what they are used for:
- a) ROM
- b) RAM
- c) CACHE

QUESTION TWO:

- A) High level languages are often said to be "people-oriented" where as low level languages are said to be "machine-oriented". What is meant by the foregoing expressions on high and low level languages?
- B) High level languages are grouped into different types/categories depending on what features they have. State any four (4) of them and give an example for each category.
- C) What are the benefits of the log-in sequence on a multi-user computer system?
- D) Write brief notes on the following:
- i) Spreadsheet

- ii) Word-processing
- iii) Sub-Program
- iv) Assembler
- v) DataBase Management Systems (DBMS)

QUESTION THREE:

PART ONE:

- A) A computer is an electronic machine capable of processing data into information. However, data can also be processed into information manually. State any four (4) advantages of using a computer instead of doing the job manually.
- B) State any four (4) functions of an Operating System.
- C) State any four (4) features you would expect a Fourth Generation Language (4GL) to have.
- D) State any four (4) features of an Expert System.
- E) A well written computer program should satisfy certain programming aims and characteristics. State any four (4) of them.

PART TWO:

All the questions under Question Three Part Two below relate to the Disk Operating System (DOS).

1. Suppose you are on drive C, what command would you use to switch to drive A?
2. Supposing the directory called "NORWAY" is one level below the root directory. A command "CD \NORWAY", changes the directory to NORWAY. Under what circumstances will a command "CD NORWAY", achieve the same results?
3. Supposing you are in the directory "C:\NORWAY\TEXT>" and you want to move to "C:\NORWAY>". State any two (2) commands/methods, which can achieve this.
4. You type a command to list the contents of a directory and you find that the output is scrolling up very fast. How would you modify the command such that you can see the output with pauses?
5. Supposing you want to copy all files whose extension is ".exe" from "C:\NORWAY\TEXT>" to "C:\PROGRAMS>". What command would you use if you are:
 - i) at the root directory,
 - ii) at the directory "C:\NORWAY\TEXT>",
 - iii) at the directory "C:\PROGRAMS>".
6. State one command you may use to delete a directory together with all its contents (i.e. sub-directories and files).
7. Groups of DOS commands can be executed together by placing them in a file and giving that file a special extension. What extension should these files have?

QUESTION FOUR:

- A) Flowcharts, Decision Tables and Pseudocode are all known as program planning tools.
- i) Give diagrammatic representation of any three (3) Flowcharting symbols naming and explaining what each symbol is used for.
 - ii) What are the four (4) main features of a Decision Table?
 - iii) Name and explain the three (3) basic control structures found in Pseudocode.

B) There are three (3) types of customers, A, B and C.

- i) Type A receives a 10% discount on all orders, except that for orders above K200,000 in value, the discount is 12%.
- ii) Type B receives a 7% discount on all orders, except that for orders above K200,000 in value, this discount is 9%.
- iii) Type C receives a 5% discount on all orders regardless of value.

Draw the Flowchart of a program, which, for batches of order records:

- a) Prints the discount for each order;
- b) Calculates the total amount of discount allowed on all orders.

- C) IF the invoice amount exceeds K500,000.00 THEN
 IF the account has any invoice more than sixty (60) days overdue THEN
 Hold the confirmation pending resolution of the debt
 ELSE { account is in good standing }
 Issue confirmation and invoice
ELSE { invoice K500,000.00 or less }
 IF the account has any invoice more than sixty (60) days overdue THEN
 Issue confirmation, invoice and write message on the credit action report
 ELSE { account is in good standing }
 Issue confirmation and invoice

Represent the above procedure on a limited entry decision table, stating why the decision table and not the flowchart is the most ideal design aid for the above procedure.

- D) You and your spouse are interested in seeing a movie tonight. You will read the newspaper together and democratically come to a decision. Here is the procedure you will follow:
- i) You will read the advertisement for each film in the newspaper;
 - ii) If you find one which you both like then you go to watch it and ignore the remaining adverts if any;
 - iii) If you read the advertisements for all the movies and haven't found any you both want to see, you will turn on the television.

Put the above procedure in a form of a Pseudocode. (N.B. Assume that there is atleast one film advert in the newspaper).

QUESTION FIVE:

- A) In Pascal, the REPEAT Statement, the WHILE Statement and the FOR Statement are termed as repetitive control structures. Write their general syntax formats and explain their differences.
- B) The program below is to display results across your computer screen. Using a dry run, simulate and write down the results, as they would appear after execution of the program.

```
Program DisplayResults;
Var
  line, position, number : integer;
Begin
  writeln;
  writeln ('The square of ');
  FOR line := 0 to 2 DO
  Begin
    FOR position := 1 to 2 DO
    Begin
      number := line * 2 + position;
      write (number:2, ' = ',(number * number):4, ' ');
    End;
    Writeln
  End
End.
```

- C) i) Trace the following section of a Pascal program to find the resulting value of "X".

```
X := 1;
N := 6;
Y := 0;
WHILE Y < N DO
BEGIN
  Y := Y + X;
  X := X + Y
END;      WRITE (X);
```

- ii) Re-Write the above code (5 C (i)) using the REPEAT – UNTIL loop.

QUESTION SIX:

- A) A programmer wrote the Pascal program to compute the sum of:

$$\frac{0.1}{0.2} + \frac{0.2}{0.3} + \frac{0.3}{0.4} + \dots + \frac{1.0}{1.1}$$

Part of the program is shown below:

```
-----
SUM := 0.0;
X   := 0.1;
WHILE X < 1.0 DO
BEGIN
  SUM := SUM + X / (X + 0.1);
  X := X + 0.1;
END;
-----
```

- i) Why did the program “run out of time” before producing the correct results?
 - ii) How do you call the type of error that caused the problem in part i) above?
 - iii) Develop the above code into a FULL program (i.e. a complete program) that will:
 - a) be error free;
 - b) produce the correct result of the sum;
 - c) report the sum in a “friendly” and formatted output.
- B) Write a Pascal program that will read a list of positive (+ve) integers (one at a time) from the screen and then report how many of them are even numbers and how many are odd numbers. The program should stop when a zero (0) is encountered.

QUESTION SEVEN:

- A) Examine the Pascal program written below:

```

1 PROGRAM LOGARITHM;
2 VAR
3     SIGN, N           : INTEGER;
4     LOGN, TERM       : REAL
5 BEGIN
6     LOGN := 0
7     SIGN := 1
8     N    := 1
9     TERM := 1;
10    WRITELN(' N LOGN TERM ');
11    WHILE TERM >= 0.00001 DO;
12    BEGIN;
13        TERM := 1 / N
14        LOGN := LOGN + TERM * SIGN;
15        WRITELN(' N LOGN TERM ')
16        N := N + 1;
17        SIGN := -SIGN
18    END
19 END

```

- i) Identify the line numbers with syntax errors and write down what the errors are.
 - ii) What will be the output given at the line numbers below when the syntax errors have been cleared and the programs executes:
 - a) line No. 10
 - b) line No. 15 after executing it in the first loop
 - c) line No. 15 after executing it in the second loop?
 - iii) What is the reason for defining some variables as integers while others are defined as real?
- B) Write a Pascal program that reads in two positive integers and calculates their greatest common divisor. The output format should be something similar to:

The greatest common divisor of “A” and “B” is “C”.

Where “A” and “B” are the two integers read in and “C” is their greatest common divisor.

END OF EXAMINATION

THE UNIVERSITY OF ZAMBIA
SCHOOL OF ENGINEERING
UNIVERSITY EXAMINATIONS MARCH 1998

EG575: ENGINEERING, MANAGEMENT & SOCIETY II

Time: Three hours

*Answer **five (5)** questions, with at least one from each section; use a separate answer booklet for each question.*

Section I: Legal Aspects of Engineering

1.

On Friday June 10, Samson Banda offers to sell his building to Michael Mulenga for the sum of K 80 000 000. Samson Banda informs Mulenga that he will leave the offer open for one week for him to think about. On Wednesday June 15, Michael Mulenga whilst at Church meets Bertha Silumesi, who tells him that she heard a rumour that Samson Banda has sold the Building to Peter Foloki. On Thursday June 16, Michael Mulenga goes to see Samson Banda and informs him that he will buy the building. Samson Banda informs Michael Mulenga that he is sorry but the building has been sold to Peter Foloki. Michael Mulenga is infuriated and sues Samson Banda alleging that a contract had already been formed. Advise Michael Mulenga.

2.

On September 2, Penza Suppliers writes to Chituta Engineer to sell some parts for a crane which Chituta is building. Penza indicates that he expects a response through the Zambian postal system no later than September 7. Penza's letter arrives at Chituta's office on September 5 and Chituta immediately posts an acceptance. Unfortunately, the letter is misdirected by the post and does not arrive at Penza's until September 12. Penza, not having heard from Chituta by the required date, sells the parts to Ng'andu Elevators. Does a contract exist. Why or why not?

3.

Write short notes on the following.

- (a) Distinction between an offer and invitation to treat.
- (b) Communication of an offer.
- (c) Revocation of an offer.
- (d) Consideration.
- (e) The Supreme Court of Zambia.

Section II: Industrial Management

4.
 - (a) Define the concept of motivation and explain differences in motivation among workers.
 - (b) What are the three main steps which should be considered when locating an industrial enterprise? Explain what is considered in each of these steps.

5.
 - (a) Assume that you a site engineer for Shimuz contractors on a major road resurfacing project. How would you attempt motivating your staff given the current government policy of wage freezes? Illustrate your answer with tangible but realistic examples.
 - (b) Compare and contrast “plant lay-out by product” and “plant lay-out by operation”

Section III: Technology, Development and the Engineer.

6.

Engineering profession and practice have a lot of flaws and temptations in the market place.

 - (i) Discuss these flaws and temptations.
 - (ii) How are existing laws of the country structured to combat these flaws and temptations.
 - (iii) What improvements would you recommend to ensure almost complete eradication of these flaws and temptations.

7.

Critically analyse the controversy that surrounds technology transfer in developing countries.

8.

Describe and discuss the alienation or marginalisation of indigenous scientific activities from production in developing countries.

END OF EG575 EXAMINATION

THE UNIVERSITY OF ZAMBIA

UNIVERSITY FIRST SEMESTER FINAL EXAMINATIONS - MARCH 1998

EM 311

TIME: THREE (3) HOURS

INSTRUCTIONS: ANSWER ANY FIVE QUESTIONS. FULL WORKING MUST BE SHOWN.

1. (a) Write down the n^{th} order Cauchy-Euler equation and write down the form of solution.
(b) Solve the differential equation $\frac{d^2y}{dx^2} + \frac{10}{x} \frac{dy}{dx} + \frac{8}{x^2}y - 1 = 0$.
2. (a) Using Rodrigues' formula find $P_0(x), P_1(x), P_2(x)$ and $P_3(x)$ and verify that $\int_{-1}^1 P_n^2(x) dx = \frac{2}{2n+1}$ for $n = 0, 1, 2, 3$.
(b) Express x^2 and x^3 in terms of Legendre polynomials and hence show that $\int_{-1}^1 x^5 dx = 0$ using the fact that the polynomials are such that $\int_{-1}^1 P_i(x)P_j(x) dx = 0 \quad i \neq j$.
3. (a) Define an ordinary point of the differential equation $a_2(x)y'' + a_1(x)y' + a_0(x)y = 0$.
(b) Solve $y'' - 2xy = 0$ expressing your answer in closed form.
4. (a) Show that $u = \ln[(x-x_0)^2 + (y-y_0)^2]$ satisfies Laplace's equation where $u \equiv u(x, y)$ is a function of x and y .
(b) Discuss the nature of the partial differential equation $u_{xx} + (x^2 - y^2)u_{yy} = 0$, whether it is parabolic, elliptic or hyperbolic.
5. (a) For the function

$$F(t) = \begin{cases} 5, & 0 < t < 3 \\ 2t+1, & 3 < t \end{cases}$$

sketch the graph of the function. Express the function in terms of Heaviside functions and hence find its Laplace transform.

(b) Evaluate $\int_0^{\pi/2} \cos^6 \theta d\theta$.

6. (a) Find the Fourier cosine series for the function $f(x) = x(\pi - x)$, $0 \leq x \leq \pi$. A graph of the function should be plotted.

(b) Show that $\sum_{n=1}^{\infty} \frac{(-1)^{n-1}}{n^2} = \frac{\pi^2}{12}$ from part (a).

7. (a) Given

$$f(x) = \begin{cases} e^{-ax}, & x > 0 \\ 0, & x < 0 \end{cases}$$

$$g(x) = \begin{cases} e^{ax}, & x < 0 \\ 0, & x > 0 \end{cases}$$

where $a > 0$, find their Fourier transforms.

(b) Hence compute $F^{-1} \left\{ \frac{1}{w^2 + a^2} \right\}$.

8. (a) Given that $J_n(x)$ is the Bessel function of order n , verify that

$$J_{-n}(x) = (-1)^n J_n(x) \text{ where } J_K(x) = \sum_{n=0}^{\infty} \frac{(-1)^n}{n!(n+K)!} \left(\frac{x}{2}\right)^{2n+K}$$

(b) Use Laplace transforms to solve the linear ordinary differential equation $\frac{d^2x}{dt^2} - x = t+1$ with initial conditions $x(0) = 0$, $x'(0) = 1$.

END OF THE EXAMINATION

THE UNIVERSITY OF ZAMBIA

UNIVERSITY FIRST SEMESTER EXAMINATIONS - MARCH 1998

EM411

ENGINEERING MATHEMATICS V

TIME: THREE (3) HOURS

INSTRUCTIONS: ATTEMPT ANY FIVE (5) QUESTIONS

1. (a) Suppose the function f is twice continuously differentiable on the interval $[a, b]$, and $x_n \in [a, b]$ is an approximation to the root of f on $[a, b]$ such that $f'(x_n) \neq 0$. The Newton-Raphson method uses the iterative scheme

$$x_{n+1} = x_n - \frac{f(x_n)}{f'(x_n)} = \phi(x_n)$$

Successive iterates converge if $|\phi'(x)| < 1$ near the root. Show that

$$|f(x)f''(x)| < [f'(x)]^2 \text{ if } |\phi'(x)| < 1.$$

- (b) (i) Show that there exists a unique solution to the equation $x = 2 \cos x - 1$ in the interval $[0, \frac{\pi}{2}]$.
- (ii) Use the Newton-Raphson method to approximate the solution to the equation in (i) with error not exceeding 10^{-3} . Use $x_0 = 1.5$.

2. Let $A = \begin{pmatrix} 1 & 0 & 1 \\ 0 & 2 & 2 \\ 1 & 2 & 3 \end{pmatrix}$ and \bar{x} be a column vector.

- (a) Show that the equation $A\bar{x} = \lambda\bar{x}$, where $\bar{x} \neq \bar{0}$, has a solution for each of the distinct values of λ .
- (b) Find solutions corresponding to each λ .
3. (a) Suppose x_0 and x_1 are two distinct points and a function $f \in C^2[x_0, x_1]$. If we let $h = x_1 - x_0$, use the first Lagrange polynomial to show that
- $$f'(x_0) = \frac{f(x_1) - f(x_0)}{h} - \frac{h}{2} f''(\epsilon) \text{ for some } \epsilon \in [x_0, x_1].$$

(b) Consider the function f defined in the table

n	0	1	2
x_n	1.5	1.6	1.7
$f(x_n)$	0.9975	0.9996	0.9917

(i) Use the formula in (a) to approximate $f(1.5)$ and find a bound for the error given that $f(x) = \sin x$

(ii) Use a second Lagrange polynomial to approximate $f(1.55)$.

4. (a) (i) Given that $\frac{dy}{dx} = f(x, y)$ for $a \leq x \leq b$, with $y(a) = \alpha$, write down a fourth order Runge-Kutta method that may be used to approximate $y(x)$ to the initial-value problem.

(ii) If $y' = -2y$, with $y(0) = 1$, use the fourth order Runge-Kutta method with step-size h to approximate $y(h)$.

(b) Use the Taylor method of order two, with $h = 0.25$ to approximate the solution to the initial-value problem

$$y' = x + y; 0 \leq x \leq 1; y(0) = -1.$$

5. (a) Define the terms

- (i) analytic function
- (ii) harmonic function

(b) Show that the function $u = \ln(x^2 + y^2)$ is harmonic and find a corresponding analytic function $f(z) = u(x, y) + iV(x, y)$.

(c) Find $\int_{\gamma} e^z dz$, where γ is the line segment from $z = -3 + 2i$ to $z = -4 + 5i$.

6. (a) Let λ be an eigenvalue of an $n \times n$ matrix $A = (a_{ij})$. Show that for some integer k , $1 \leq k \leq n$,

$$|a_{kk} - \lambda| \leq |a_{k1}| + |a_{k2}| + \dots + |a_{kk-1}| + |a_{kk+1}| + \dots + |a_{kn}|$$

(b) Let $A = \begin{pmatrix} 3 & -1 & 1 \\ 0 & 5 & -4 \\ 1 & 1 & -4 \end{pmatrix}$, $B = \begin{pmatrix} 1 & -1 & 0 \\ -1 & 2 & -1 \\ 0 & -1 & 1 \end{pmatrix}$.

- (i) Determine and sketch the disks which contain the eigenvalues of A .
- (ii) If $\rho(A) = \max_{1 \leq i \leq n} |\lambda_i|$, determine the bounds for $\rho(A)$.
- (iii) Apply the power method to approximate the dominant eigenvalue λ and corresponding eigenvector \bar{x} of B . Use $\bar{x}_0 = (1, -1, 2)^T$ and do four iterations.
7. (a) Let $I = \int_0^2 e^{-x} dx$.
- (i) Approximate I using the trapezoidal rule with $n = 4$.
- (ii) Find the values of n needed for I to have error less than 10^{-5} .
- (b) Let $P_2(x)$ be the Lagrange interpolating polynomial for the data $(0, 0)$, $(0.5, y)$, $(1, 3)$. Find y if the coefficient of x^2 in $P_2(x)$ is -11 .

END OF EXAMINATION

THE UNIVERSITY OF ZAMBIA
SCHOOL OF ENGINEERING
DEPARTMENT OF MECHANICAL ENGINEERING

UNIVERSITY SEMESTER I EXAMINATIONS - MARCH, 1998

ME 341 - THERMODYNAMICS I

TIME: THREE (3) HOURS

CLOSED BOOK

- INSTRUCTIONS:**
- ANSWER FIVE (5) Questions only
 - ANSWER At least two (2) Questions from each section
 - All Questions Carry Equal Marks
 - Use separate answer books for each section
 - Steam Tables, Mollier Charts, Freon Tables and Charts may be used

SECTION A

Answer Question ONE (1) and At least One other Question from this Section

Q1. The following statements are either true or false. Indicate which by writing down the appropriate letter in your answer book.

Marking: $\left[\text{Number correct} - \frac{\text{Number Incorrect}}{2} \right] \times 1.25$

- | | | | |
|-------|---|---|---|
| (i) | A Nozzle is a device for converting pressure energy into kinetic energy. | T | F |
| (ii) | It is impossible to devise a machine to deliver a limited quantity of work without requiring a source of energy in the surroundings. | T | F |
| (iii) | Quality (x) is a thermodynamic property. | T | F |
| (iv) | If a change of state in one system requires corresponding changes in another system, it is said that there is an interaction between the two systems. | T | F |
| (v) | A process that involves no interactions other than work is called an adiabatic process. | T | F |

- (vi) The coefficient of performance of a Carnot refrigerator working between temperature limits T_1 and T_2 ($T_1 > T_2$) is $\frac{T_1}{T_1 - T_2}$ T F
- (vii) A wet vapour is a perfect gas. T F
- (viii) The entropy change between two states is determined by the process which produces the change. T F
- (ix) In an adiabatic expansion process (closed system), the temperature of the working fluid rises. T F
- (x) In a throttling process, the change of enthalpy is proportional to the change in pressure. T F
- (xi) For a perfect gas in an adiabatic process which is reversible steady flow, work transfer is given as ${}_1W_2 = c_p(T_1 - T_2)$. T F
- (xii) If water is at a pressure lower than the critical pressure, it is always in a liquid phase. T F
- (xiii) For a perfect gas in a isentropic non-flow process, work transfer is given as $({}_1W_2)_s = c_v(T_1 - T_2)$ T F
- (xiv) A system of a pure substance cannot consist of several co-existing phases, say gas and liquid. T F
- (xv) If two reversible heat engines work between the same source and sink, one engine using an ideal gas, the other steam, the engine using an ideal gas will have the higher efficiency. T F
- (xvi) A device converting heat transfer into work transfer is a heat pump. T F

- Q2. (a) Identify the proper type of system (isolated, closed or open) to be used in the analysis of each of the following, and explain (briefly) your reasons.
- (i) the universe
 - (ii) an electrical generator
 - (iii) a kitchen refrigerator.
- (b) Show that no heat engine receiving heat from a heat source at temperature T_1 and rejecting heat at a temperature T_2 can be more efficient than a Carnot engine operating between the same temperatures ($T_1 > T_2$).

- (c) An engineer has invented an automobile engine that operates in a closed cycle, with the working fluid receiving heat from combustion gases at 1500°C and rejecting heat to ambient air at 25°C . He claims that for steady fuel flow of 0.0012 kg/s , his engine can produce 45 kW . Evaluate this claim. Assume that for each kilogram of fuel burned, 44 MJ of heat are transferred into the working fluid.

- Q3. (a) An inventor claims to have developed an engine that operates on a cycle that consists of two reversible adiabatic processes and one reversible isothermal heat addition process as follows:

- 1 - 2 Isothermal heat addition
- 2 - 3 Adiabatic Expansion
- 3 - 1 Adiabatic Compression.

Explain whether this engine violates either the First or Second laws of Thermodynamics.

- (b) 0.025 m^3 of air at 15°C and 5 bar is heated at constant pressure to a temperature of 204°C and then expanded adiabatically until the temperature falls to 120°C . It is then cooled at constant volume to 15°C and restored to its initial volume by an isothermal compression.

Draw the cycle in a P-V diagram and determine

- (i) the heat supplied or rejected during the four phases of the cycle;
- (ii) the work done;
- (iii) the thermal efficiency of the cycle.

For air, take $c_p = 1\text{ kJ/kg.K}$ and the adiabatic index as 1.4 . Consider air as an ideal gas.

- Q4. (a) A perfect gas leaks through a valve from a thermally insulated cylinder into an initially evacuated second cylinder, which is also thermally insulated. Show by logical thermodynamic argument that this process is irreversible.

- (b) Steam enters a turbine at a rate of 8 kg/s . The conditions at the inlet are $P_1 = 6.0\text{ MPa}$ and $T_1 = 500^{\circ}\text{C}$, and the pressure at the exit is $P_2 = 0.1\text{ MPa}$. The isentropic efficiency is 0.8 . Find

- (i) The power delivered by the turbine
- (ii) The change in the specific entropy of the steam passing through the turbine.

END OF SECTION A

SECTION B

ANSWER AT LEAST TWO QUESTIONS FROM THIS SECTION

- Q5. (i) Discuss the various processes occurring in the Carnot cycle with the help of P-V and T-S diagrams.
- (ii) Prove that the thermal efficiency of a Carnot cycle is governed by the equation

$$\eta = 1 - \frac{1}{r_v^{(k-1)}}$$

where r_v is the adiabatic compression

- Q6. (i) With the help of a P-V diagram, discuss the principle of operation of a reciprocating compressor.
- (ii) Determine the theoretical work input per 1 m³ of air for a single stage compressor used to compress air to a pressure of 125 bar. Initial pressure is 1 bar and temperature 300 K. The polytropic exponent is assumed to be 1.2.

Determine also the temperature at the end of polytropic compression.

- Q7. A four stroke cycle single cylinder engine, with a swept volume of 14 litres, and having a piston diameter of 24 cm, is coupled to a dynamometer with an effective brake radius of 0.7 m and leaves a load of 77 kgf. A mechanical indicator with a string calibration of 27 KN/m²/mm is used to obtain a P-V diagram with a diagram area of 840 mm² and diagram length of 40 mm. To obtain a crankshaft speed of 400 revolutions per minute, the engine uses diesel, with a calorific value of 44,000 kJ/kg at 7.2 kg per hour. Water at a flow rate of 540 kg/hr is used to cool the engine and enters the engine at 38^o C and leaves at 71^o C. Specific heat of water is given as 4.18 kJ/kg ^oC. Energy equivalent to the exhaust gases is given as 30.6 KW.

Determine

- (i) Indicated power
(ii) Brake power
(iii) Energy balance and also as a percentage of the overall.

END OF ME 341 EXAMINATION
Dr. A.N. Ng'andu\Prof. F.D. Yamba

UNIVERSITY OF ZAMBIA
SCHOOL OF ENGINEERING
DEPARTMENT OF MECHANICAL ENGINEERING
UNIVERSITY EXAMINATIONS - SEMESTER I, MARCH 1998

ME 415 PRODUCTION TECHNOLOGY I

CLOSED BOOK

TIME: THREE HOURS.

ANSWER: FIVE QUESTIONS, AT LEAST TWO FROM EACH SECTION;

SECTIONS A AND B TO BE ANSWERED IN SEPARATE BOOKS.

SECTION A.

- (a) With the help of clearly labelled sketches, describe how you would manufacture hollow aluminium cylindrical products using the green sand and CO₂ casting processes. Product dimensions are as follows: outside $\phi 90$ mm, internal $\phi 70$ mm, length 100 mm.

(10 marks)

- (b) What are the likely defects associated with this method of manufacturing hollow cylindrical products and how would the defects be eliminated?

(10 marks)

- (a) Discuss general causes of errors in mechanical measurements. Give sketches to illustrate your discussion where possible.

(10 marks)

- (b) Determine the instrument error when a vernier caliper with a beam curve of 0.06 mm is set to measure 299 mm. The caliper jaw length is 60 mm. Derive any expressions used.

(10 marks)

- (a) With help of sketches, describe a method for measuring the virtual effective diameter of an ISO metric thread. Derive any expressions used in the method you have described.

(10 marks)

Q3. (Cont'd)

(b) Give an outline of the method you would use to measure the following screw thread parameters:

- (i) flank angle,
- (ii) pitch.

(10 marks)

Q4. (a) Derive an expression that relates the equivalent spur gear and the helical gear to be cut using the profile milling process of gear production.

(b) Given the following:

(14 marks)

Number of teeth for the helical gear to be cut = 50;
Helical angle = 30 deg.

<i>Cutter No.</i>	<i>No. of spur teeth to be cut.</i>
1	Rack - 135
1.5	134 - 80
2	79 - 55
2.5	54 - 42
3	41 - 35
3.5	34 - 30
4	29 - 26
4.5	25 - 23
5	22 - 21
5.5	20 - 19
6	18 - 17
6.5	16 - 15
7	14
7.5	13
8	12

Select a cutter from the table above to be used for milling the helical gear. Comment on the accuracy of the profile to be cut using the chosen cutter.

(6 marks)

SECTION B.

- Q5. (a) State the 4 main assumptions of Merchant's theory of cutting. (2 marks)
- (b) From Merchant's circle, Derive expressions in terms F_v and F_p for:
- (i) Force along the rake face. (4 marks)
 - (ii) Force normal to the rake face. (4 marks)
- (c) Using the shear angle predicted by Merchant, calculate for the following conditions:

Cutting velocity	$V = 240$ m/min
Tool rake angle	$\gamma = +6^\circ$
Cut thickness	$h = 0.45$ mm
Width of cut	$b = 4.20$ mm
Shear stress on shear plane	$\tau_\phi = 600$ N/mm ²
Apparent coefficient of friction	$\mu = 0.70$

- (i) Cutting force (2.5 marks)
- (ii) feed force (2.5 marks)
- (iii) Force along the rake face (2.5 marks)
- (iv) Force normal to the rake face (2.5 marks)

- Q6. (a) State 5 main economic and production requirements for the selection of a suitable cutting tool material. (5 marks)
- (b) Briefly describe the 5 basic wear mechanisms (with diagrams) considered in metal cutting. (10 marks)
- (c) State whether the following statements are TRUE or FALSE in reference to cutting tool materials: (5 marks)
- (i) Hard cutting HSS requires very high room temperature hardness.
 - (ii) Fast cutting HSS requires high toughness.
 - (iii) Cubic Boron Nitride Compacts have good performance in interrupted cutting.
 - (iv) In carbides, increasing the Co content increases the crater resistance.
 - (v) In carbides, increasing the TiC content increases thermal conductivity.
 - (vi) In carbides, increasing the TaC (NbC) content increases Hot hardness.
 - (vii) In carbides, increasing the Co content increases Wear resistance.
 - (viii) In carbides, increasing the TiC content reduces strength.
 - (ix) In HSS, increasing the Co content increases toughness.
 - (x) In HSS, increasing the Cr content improves hardness penetration.

- Q7. (a) Derive expressions for:
- (i) Maximum chip thickness for up-cut milling. (4 marks)
 - (ii) Mean chip thickness (Schlesinger's formula). (4 marks)
- (b) Given:
- | | |
|---------------------------|------------------------|
| Diameter of cutter | 132 mm |
| No. of teeth | 8 teeth |
| Depth of cut | 7 mm |
| Cutter speed | 40 m/min |
| table feed | 145 mm/min |
| Width of slot | 15 mm |
| Specific cutting pressure | 4150 N/mm ² |
- Find:
- (i) The maximum chip thickness for climb milling. (3 marks)
 - (ii) The mean chip thickness using Schlesinger's formula. (3 marks)
 - (iii) Power required by the cutter in (kW) (3 marks)
 - (iv) The maximum number of teeth in engagement. (3 marks)
- Q8. (a) For the heavy duty metal lathe shown in Figure No.1, name the parts numbered 1 to 5. (5 marks)
- (b) For the shaper in Figure No.2 name the parts numbered 1 to 5. (5 marks)
- (c) Briefly describe the working of a coil fed lathe. (5 marks)
- (d) Briefly describe the working of a broaching machine, and give examples of the products that can be produced from broaching. (5 marks)

END OF EXAMINATION

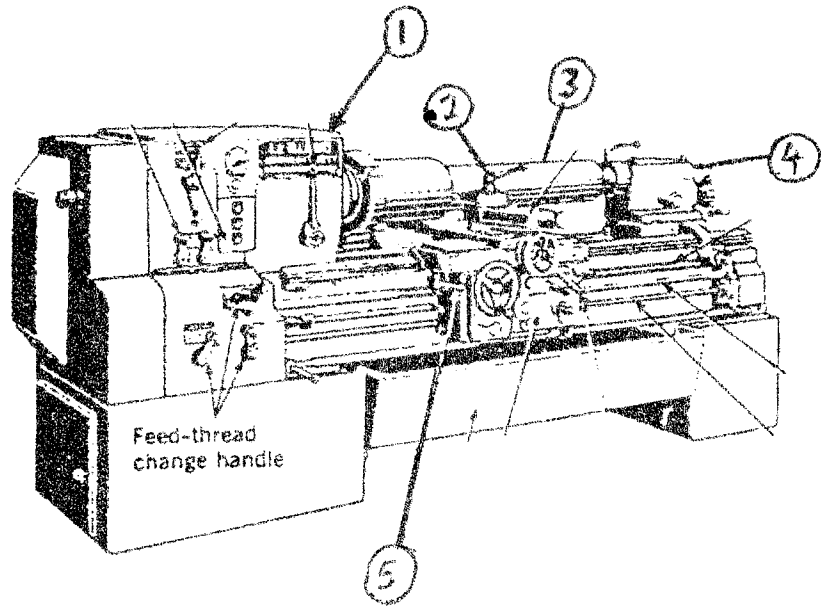

FIGURE No.1 : A TYPICAL HEAVY DUTY LATHE

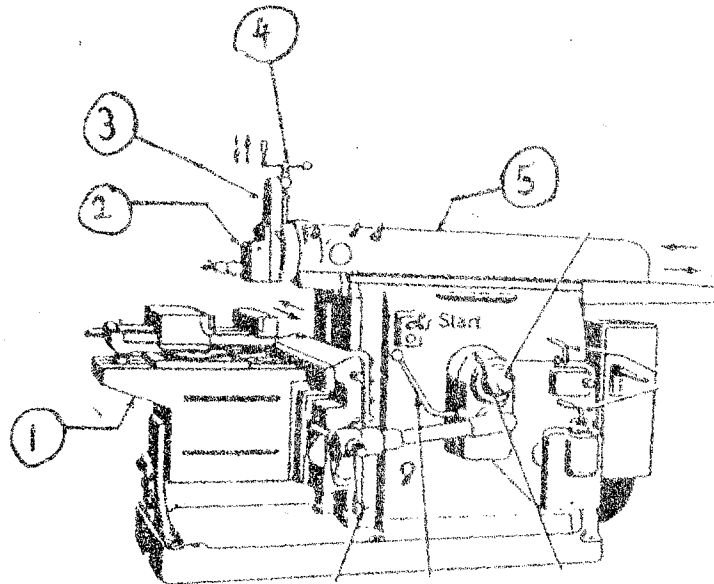

FIGURE No.2 : A SHAPER

THE UNIVERSITY OF ZAMBIA
SCHOOL OF ENGINEERING
DEPARTMENT OF MECHANICAL ENGINEERING

UNIVERSITY SEMESTER I EXAMINATIONS - MARCH, 1998

ME 431 STRENGTH OF MATERIALS II

TIME: **THREE (3) HOURS**

CLOSED BOOK

ANSWER: **FIVE (5) QUESTIONS**

ALL QUESTIONS CARRY EQUAL MARKS

- Q1. A solid AISI 1020 steel shaft is required to transmit power of 50 kW. The speed of the shaft will be 6 r/s. The allowable shear stress is 67 MPa and the allowable angle of twist (per meter of shaft length) is not to exceed 0.065 radians.

Determine the required diameter of the shaft.

- Q2. A 100 mm nominal diameter standard-weight steel pipe is used as simple beam with a span length of 4m. The member is loaded as shown in fig Q2.

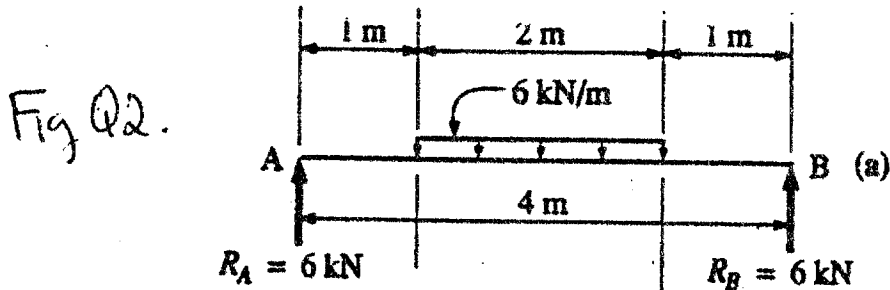

If the weight of the pipe is neglected, Calculate the deflection at midspan.

- Q3. A steel cylinder of 300mm diameter contains a gas at a gauge pressure of 1.5 MPa. Using a steel having a yield stress of 350 MPa and a factor of safety (based on yielding) of 3.0, Calculate the required wall thickness of the cylinder.
- Q4. A railway line uses steel rails ($E=200$ GPa) with a depth of 184 mm. The distance from the top of the rail to its centroid is 99.1 mm, and the moment of inertia of the rail is $36.9 \times 10^6 \text{ mm}^4$.

The rail is supported by ties, ballast, and a road bed that together are assumed to act as an elastic foundation with spring constant $K=14.0 \text{ N/mm}^2$.

Determine:

- (a) the maximum deflection
- (b) maximum bending moment
- (c) maximum flexure stress
in the rail for a single wheel load of 170 kN.

Q5. A built-in beam of span 12m carries a uniformly distributed load of 10 kN/m over its whole length together with concentrated loads of 20 kN at 3m and 30 kN at 8 m from one end. If the bending stress is limited to 100 N/mm^2 , calculate the section modulus required, and sketch the bending moment diagram.

Q6. A steel shaft 50 mm diameter is to be pressed into a cast-iron hub 150 mm external diameter and 100 mm long, so that no relative slip occurs under a torque of 5 kNm.

- (a) Find the necessary force fit allowance and the maximum circumferential stress in the hub. $E_s = 2E_{ci}$. Poisson's ratio = 0.25 for both, and coefficient of friction between surfaces = 0.3.
- (b) If, after assembly, the shaft is subjected to an axial compressive stress of 80 N/mm^2 , what is the resulting increase in the maximum circumferential hub stress.

Q7. (a) From Paris Equation for propagation of cracks under fatigue loading, derive an expression to determine the remaining life to fracture for a cracked structure. Given initial crack size, a_0

Fracture Toughness	K_{IC}
Applied stress (maximum)	σ_{max}
Applied stress (minimum)	σ_{min}
Remaining life,	N_f
The material constraints are C and m.	

- (b) A machine element is to be constructed in the form of a plate from either (i) mild steel with $\sigma_y = 207 \text{ MNm}^{-2}$, $K_{IC} = 200 \text{ MNm}^{-3/2}$
or (ii) Low Alloy Steel with $\sigma_y = 500 \text{ MN}^{-2}$
 $K_{IC} = 160 \text{ MNm}^{-3/2}$.

For a safety factor of two on the yield stress, show which of these materials would tolerate a longer crack.

END OF EXAMINATION ME 431
Dr. S.B. Kanyanga and Dr. C.K. Wamukwamba

- i) Determine the angle of incidence of the airfoil.
 ii) Find the power required to propel the aircraft assuming that 20% of the total drag comes from the wing.
- 3)
- Develop a formula for the theoretical discharge over a square notch. What is the error in the observed discharge if the measured height is wrong by 1%?
 - Develop a formula for the theoretical discharge over a V-notch. What is the error in the observed discharge if the measured height is wrong by 1%?
 - Give four different methods of measuring the velocity and indicate their advantages and disadvantages.
- 4) Consider the tilted flat-plate-bearing sketched below.
- Qualitatively explain the change along the direction of U in the velocity profiles of the fluid in the bearing, assuming that the lower plate is moving to the right. Also indicate the variation in the pressure gradient. For this direction of movement of the lower plate, is the total pressure positive or negative? Also explain the variation in the wall shear stress along the upper and the lower wall and sketch the velocity profiles for the locations where these are zero.
 - Derive the formula for the pressure distribution between the two plates (of infinite width) to be

$$p = -\frac{6\mu U (h_1 - h)(h - h_2)}{m (h_1 + h_2)h^2}$$
 - Consider a bearing filled with oil with viscosity $\mu = 0.1 \text{ kg/ms}$, density $\rho = 1000 \text{ kg/m}^3$ and bearings with length 0.1 meter, height $h_1 = 10^{-4} \text{ m}$ and height $h_2 = 2 \times 10^{-4} \text{ m}$, where the lower plate is moving with a velocity $U = 10 \text{ m/s}$. Find the total force on the plates.

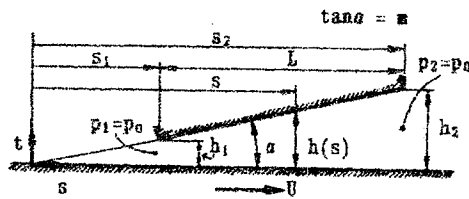

- 5) To find the force of the water on a pier at the mouth of a river, a scale model of the harbor is built where the horizontal and vertical scales are both scaled with a factor A : $A = L_p / L_m = z_p / z_m$, where the index m stands for the model and p for the prototype, L for the horizontal scales and z for the vertical scales. Viscous effects can be ignored.
- Determine the ratio of the frequency of the tides as a function of A . Which two dimensionless numbers are important here?
 - Find the ratio of the drag forces per unit area for the case of the model as compared to the real pier (assuming that the mass densities are the same in the case of the model and the prototype).
 - Explain the significance of the Reynolds number, the Froude number and the Strouhal number.
- 6) An axial flow pump has a rotor tip diameter 2.0 meter and hub diameter 1.0 meter. The rotational speed is 300 rpm and the blade angles are 21° with the tangential direction at inlet and 25° with the tangential at outlet. The inlet whirl is zero and the pumped fluid is water ($\rho = 1000 \text{ kg/m}^3$).
- Sketch the mean diameter velocity triangles (assuming shock free flow).

- b) Give the Power required, assuming that the total efficiency of the pump is 85%.
 c) In this problem, shock free flow is assumed. What does this mean and why is this important?

7)

- a) For a laminar pipe-flow, we found the velocity profile analytically from equilibrium of forces. Explain why we cannot use the same method to find the velocity profile for a turbulent flow.
 b) If the average velocity in a laminar pipe flow is 2 m/s , what is the maximum velocity in the pipe? And what would have been the maximum velocity if this flow would have been turbulent? (Use $u/U_{\text{max}} = [(r_0 - r)/r_0]^{1/7}$). Also sketch the velocity profiles for a laminar pipe flow and a turbulent pipe flow for the same average velocity.
 c) A pipe has diameter $D = 0.1 \text{ m}$ and length $L = 10 \text{ m}$. The pressure at the beginning of the pipe is $p = 1.25 \times 10^5 \text{ Pa}$ and at the end of the pipe it is $p = 1.0 \times 10^5 \text{ Pa}$. Assume that water is the working fluid with a density of 1000 kg/m^3 and that we can ignore all end-effects in the pipe and assume the flow to be a fully developed pipe flow throughout.
 i) Find the discharge if the pipe is made of cast iron ($k = 0.26 \text{ mm}$)
 ii) If the pipe is now polished until smooth. What will be the new discharge?
 (Hint: you might need some iteration. However, it is also possible to use the lines for constant values of $\text{Re} \sqrt{f}$ indicated in the figure.)

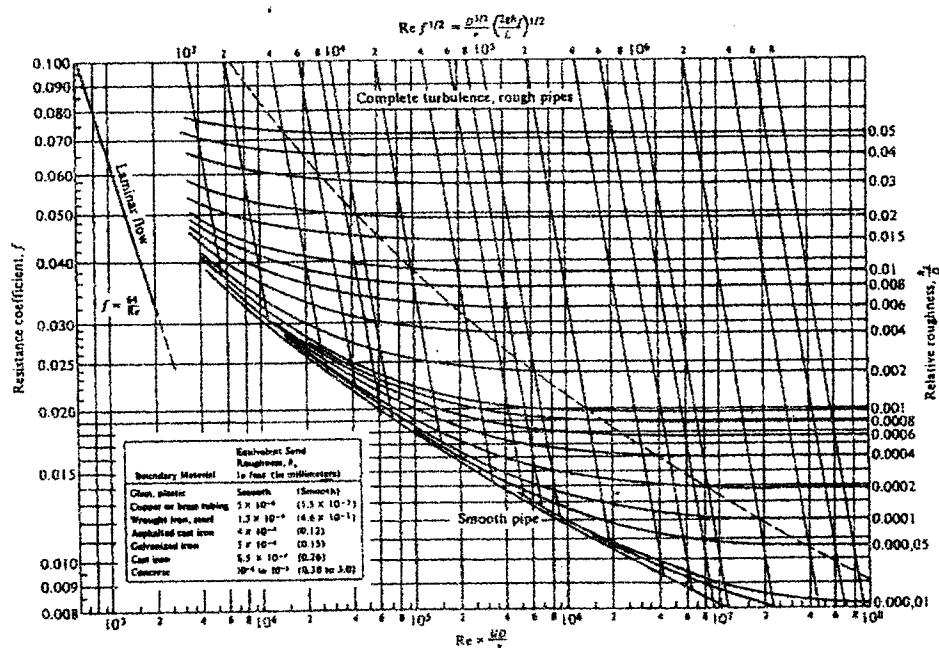

NB: The form of the Darcy equation corresponding to this graph is $h_f = f \frac{L \bar{u}^2}{D 2g}$

End of Examination ME 461
 Dr. H.A. Zondag

**The University of Zambia
School of Engineering
Department of Mechanical Engineering**

**ME541-Heat Transfer
Semester I Examination – March 1998**

Instructions:

Answer all questions from section A and any three (3) questions from section B

Time: 3 hours

Closed book

Section A

Question 1

An electric, plane composite, pad is installed in a room to heat the room in winter. The pad is made up of two materials, A and B. Pad material A has internal heat generation $q = 1.5 \times 10^6 \text{ W/m}^3$, $K_A = 75 \text{ W/m.K}$, and thickness $L_A = 50 \text{ mm}$. Pad material B has no internal heat generation, with $K_B = 150 \text{ W/m.K}$ and thickness $L_B = 20 \text{ mm}$. The unbounded surface of the material A is well insulated while that the unbounded surface of material B is cooled by a stream of air in the room with $T_\infty = 30 \text{ }^\circ\text{C}$ and $h_c = 1000 \text{ W/m}^2.\text{K}$.

- 1.1 Sketch the temperature distribution that exist in the composite pad under steady state conditions.
- 1.2 State all the necessary assumptions which underlines the process of heat transfer in the situation as described in questions 1 and 1.1.
- 1.3 Determine temperature T_0 of the insulated surface and temperature T_2 of the cooled surface.

Question 2

- 2.1 Briefly discuss why the knowledge of mean temperature difference is required in heat exchangers and find its expression.
- 2.2 A shell and tube (single pass) counter flow heat exchanger is used to cool beer, in breweries factory, from the temperature of $22 \text{ }^\circ\text{C}$ to $6 \text{ }^\circ\text{C}$. Liquid nitrogen is employed, for cooling, in the shell with the inlet temperature of $-2 \text{ }^\circ\text{C}$ and leaves the shell at $3 \text{ }^\circ\text{C}$. The overall heat transfer is taken to be $U_m = 500 \text{ W/m}^2.\text{ }^\circ\text{C}$. Calculate the heat transfer surface area for the design heat load of 10 KW .

Section B

Question 3

Consider a 1.6 cm thick carbon fiber at the initial temperature of $T = 600\text{ }^{\circ}\text{C}$. The plate dipped at time $t = 0$ (Zero) in a bath of water at the temperature of $T_{\infty} = 15\text{ }^{\circ}\text{C}$. The heat transfer coefficient is assumed to be constant and equal to $h = 10^4\text{ W/m}^2\cdot\text{K}$. The properties of carbon fiber are: $K = 40\text{ W/m}\cdot^{\circ}\text{C}$, $\rho = 7850\text{ Kg/m}^3$, $C_p = 460\text{ J/kg }^{\circ}\text{C}$ and $\alpha = 0.1\text{ cm}^2/\text{s}$.

- 3.1 Calculate The time t when the temperature in the midplane of the carbon fiber drops to $100\text{ }^{\circ}\text{C}$,
- 3.2 Determine the corresponding temperature in a plane situated at 0.2 cm under one of the cold surfaces.
- 3.3 For the same time interval t , calculate the heat transfer leased by the plate assuming a unit area.

Question 4

The cylinder of an air cooled Kawasaki motor cycle is make up of Aluminum (2024-T6) alloy. The height of the cylinder is $H = 0.20\text{ m}$ and outside diameter is 60 mm . At the optimum operating conditions of the motor cycle, the outside of the cylinder is at 600 K and is in contact with ambient air at 300 K . The heat transfer coefficient of ambient air is $60\text{ w/m}^2\cdot\text{K}$. In order to enhance heat transfer to the surrounding, annular fins of rectangular cross sections are added to the cylinder. Assuming five evenly spaced fins, of the thickness $t = 8\text{ mm}$ and length $L = 20\text{ mm}$, are sufficient to cover the entire height of the cylinder. Assuming the following conditions to be prevalent

- Steady-state heat transfer.
 - One-dimensional radial conduction in fins,
 - Constant material properties.
 - No internal heat generation,
 - Negligible radiation exchange with surroundings,
 - Uniform convection coefficient over the outer surface (with or without fins)
- 4.1 quantify the increase in heat transfer due to the addition of fins
 - 4.2 What are your comments on the answer obtained in question 4.1?

Question 5

A house has a composite wall of wood, fiberglass insulation, and plaster board, as indicated in the sketch. On a cold winter day the convection heat transfer coefficients are $h_o = 60 \text{ W/m}^2\cdot\text{K}$ and $h_i = 30 \text{ W/m}^2\cdot\text{K}$. The total wall surface area is 350 m^2 .

- 5.1 Write a symbolic expression for the total resistance of the wall, including the inside and outside convection effect for the prescribed conditions.
- 5.2 Determine the total heat loss through the wall.
- 5.3 If the wind was blowing violently, raising h_o to $300 \text{ W/m}^2\cdot\text{K}$, determine the percentage increase in the heat loss.

Question 6

A secondary school class is conducting an experiment with a sphere of diameter $D = 2.5 \text{ cm}$ in a room at $T_\infty = 300 \text{ K}$ and air free stream velocity $U_\infty = 30 \text{ m/s}$ flowing across a sphere. The surface of the sphere is maintained at uniform temperature $T_w = 400 \text{ K}$ by heating using a Bensen burner

- 6.1 Calculate the average heat transfer coefficient (h_m).
- 6.2 Find the heat transfer rate (Q) from the sphere.
- 6.3 Find the average drag coefficient (C_D).
- 6.4 Determine the drag force (F) acting on the sphere.

NB: This examination sheet has supplementary data sheets

End of Examination ME-541
P.C. Chisale (Dr.) © 1998

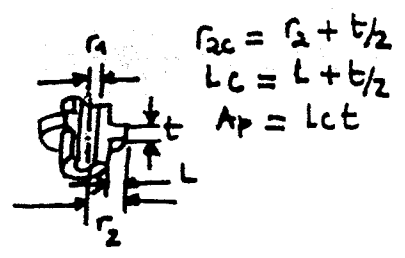
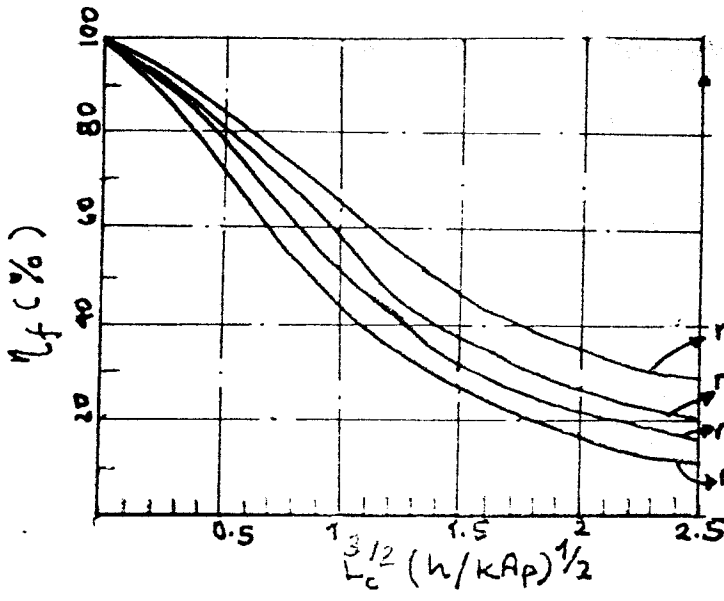

$r_{2c} = r_2 + t/2$
 $L_c = L + t/2$
 $A_p = Lct$

$r_{2c}/r_1 = \text{radius}$

Question 5

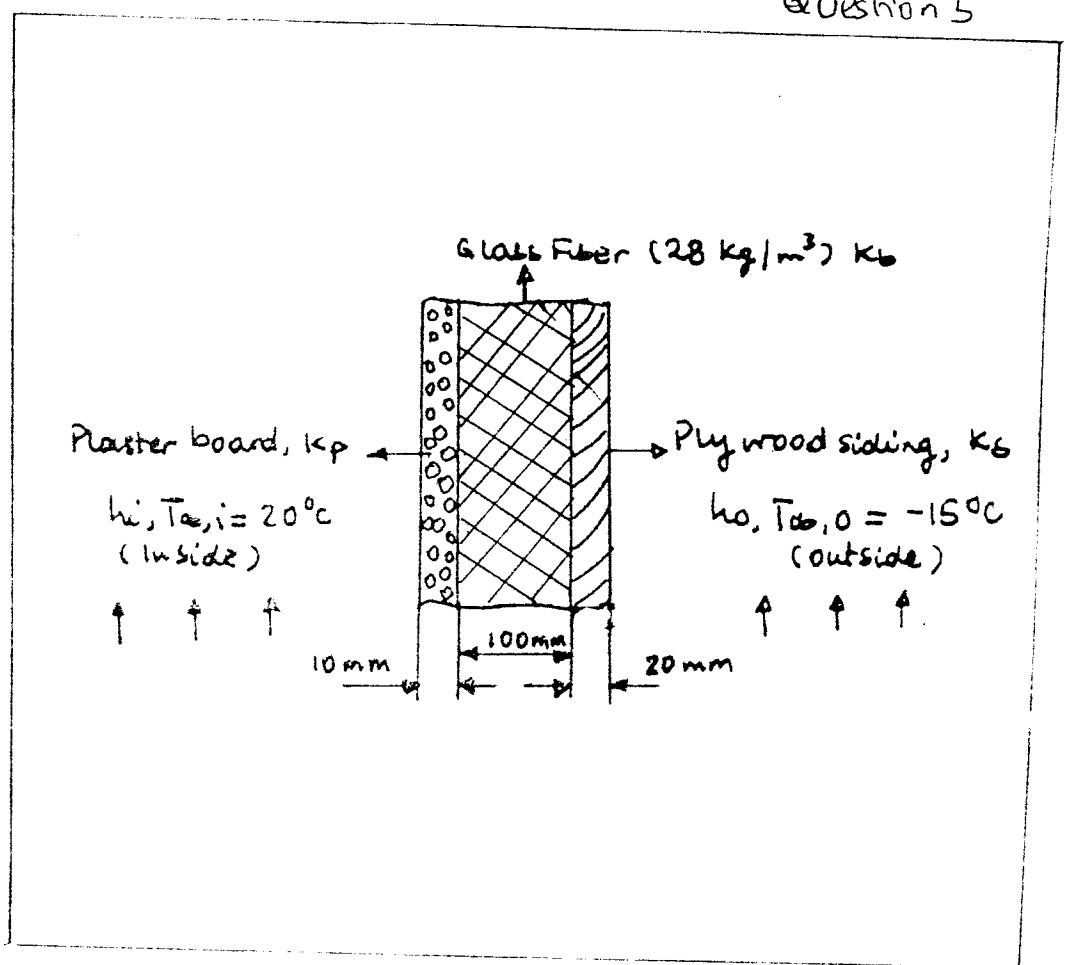

Table 8-6 Summary of correlations for forced convection over bodies*

Equation number	Correlation	Flow regime	Remarks
(8-19)	$c_x = \frac{0.664}{Re_x^{1/2}}$ (local)	Laminar	Flow over a flat plate for $Re_x \leq 5 \times 10^5$
(8-21)	$c_m = \frac{1.328}{Re_L^{1/2}}$ (average)	Laminar	Flow over a flat plate for $Re_L \leq 5 \times 10^5$
(8-22)	$\frac{\delta(x)}{x} = \frac{4.96}{Re_x^{1/2}}$	Laminar	Flow over a flat plate for $Re_x \leq 5 \times 10^5$
(8-24)	$c_x = 0.0592 Re_x^{-0.2}$ (local)	Turbulent	Flow over a flat plate for $5 \times 10^5 < Re_x < 10^7$
(8-25)	$c_x = 0.370(\log Re_x)^{-2.584}$ (local)	Turbulent	Flow over a flat plate for $10^7 < Re_x < 10^9$
(8-25b)	$c_m = 0.074 Re_L^{-0.2} - \frac{B}{Re_L}$ (average)	Laminar and turbulent	Flow over a flat plate for $Re_x < Re_L < 10^7$
(8-26b)	$\frac{\delta(x)}{x} = 0.381 Re_x^{-1/5} - 10,256 Re_x^{-1}$	Laminar and turbulent	Flow over a flat plate for $5 \times 10^5 < Re_x < 10^7$
(8-45)	$Nu_x = 0.564 Pe_x^{1/2}$ (local)	Laminar	Flow over a flat plate, constant wall temperatures $Pr \ll 1$
(8-67)	$Nu_x = 0.332 Pr^{1/3} Re_x^{1/2}$ (local)	Laminar	Flow over a flat plate, constant wall temperature.
(8-73a)	$St_x Pr^{2/3} = 0.0296 Re_x^{-0.2}$ (local)	Turbulent	Flow over a flat plate for $5 \times 10^5 < Re_x < 10^7$ $Re_x \leq 5 \times 10^5; 0.6 < Pr < 10$
(8-68)	$Nu_x = 0.339 Pr^{1/3} Re_x^{1/2}$ (local)	Laminar	Flow over a flat plate, constant wall temperature. $Re_x \leq 5 \times 10^5, Pr \geq 1$
(8-71a)	$Nu_m = 0.664 Pr^{1/3} Re_L^{1/2}$ (average)	Laminar	Flow over a flat plate, constant wall temperature. $Re_L \leq 5 \times 10^5; 0.6 < Pr < 10$

* Fluid properties are evaluated at the film temperature $T_f = (T_w + T_\infty)/2$ if no viscosity correction is included.

Table 8-6 (Continued)

Equation number	Correlation	Flow regime	Remarks
(8-71b)	$Nu_m = 0.678 Pr^{1/3} Re_L^{1/2}$ (average)	Laminar	Flow over a flat plate, constant wall temperature, $Re_L \leq 5 \times 10^5, Pr \geq 1$
(8-73a)	$St_x Pr^{2/3} = 0.0296 Re_x^{-0.2}$ (local)	Turbulent	Flow over a flat plate for $5 \times 10^5 > Re_x > 10^7$
(8-73b)	$St_x Pr^{2/3} = 0.185(\log Re_x)^{-2.584}$ (local)	Turbulent	Flow over a flat plate for $10^7 < Re_x < 10^9$
(8-74)	$Nu_x = 0.029 Re_x^{0.8} Pr^{0.43}$ (local)	Turbulent	Flow over a flat plate for $Re_x > 2 \times 10^5$ to 5×10^5
(8-78)	$Nu_m = 0.036 Pr^{0.43} \cdot (Re_L^{0.8} - 9200) \left(\frac{\mu_\infty}{\mu_w}\right)^{0.25}$ (average)	Laminar and turbulent	Flow over a flat plate, small free-stream turbulence, for $2 \times 10^5 < Re_L < 5.5 \times 10^6$ $0.70 < Pr < 380$ $0.26 < \frac{\mu_\infty}{\mu_w} < 3.5$
(8-81)	$Nu_m = (0.4 Re^{0.5} + 0.06 Re^{2/3}) \cdot Pr^{0.4} \cdot \left(\frac{\mu_\infty}{\mu_w}\right)^{0.25}$		Flow across a single cylinder, for $40 < Re < 10^5$ $0.67 < Pr < 300$ $0.25 < \frac{\mu_\infty}{\mu_w} < 5.2$
(8-82)	$Nu_m = 0.3 + \frac{0.62 Re^{1/2} Pr^{1/3}}{[1 + (0.4/Pr)^{1/4}]^{1/4}} \left[1 + \left(\frac{Re}{282,000}\right)^{5/8}\right]^{4/5}$		Flow across a single cylinder, for $10^2 < Re < 10^5$ and $Pe = Re Pr > 0.2$
(8-84)	$Nu_m = (0.8237 - \ln Pe^{1/2})^{-1}$		Flow across a single cylinder for $Pe < 0.2$
(8-85)	$Nu_m = c \left(\frac{u_\infty D_c}{\nu}\right)^n$ constant c and n are given in Table 8-2		Flow across a single noncircular cylinder

(8-87) $Nu_m = 0.37 Re^{0.4}$

Flow of gases across a single sphere for $17 < Re < 70,000$

(8-88) $Nu_m = 2 + (0.4 Re^{0.5} + 0.06 Re^{2/3}) \cdot Pr^{0.4} \left(\frac{\mu_s}{\mu_w} \right)^{0.25}$

Flow across a single sphere for

$$3.5 < Re < 8 \times 10^4$$

$$0.7 < Pr < 380$$

$$1 < \frac{\mu_s}{\mu_w} < 3.2$$

(8-95a) $\frac{h_m D}{k} = 1.13 c_0 Re^n Pr^{1/3}$

where $Re = DG_{max}/\mu$; coefficients c_0 and n given in Table 8-3

Flow across tube bundles having 10 or more transverse rows in direction of flow and for $2000 < Re < 40,000$, $Pr > 0.7$, $N \geq 10$

(8-96) $h_N = c_1 h_{N \geq 10}$
Correction factor c_1 is given in Table 8-4.

To correct h_m given by Eq. (8-95a) for tube bundles having $1 \leq N < 10$

(8-97) $\frac{h_m D}{k} = c_2 Re^m Pr^{0.36} \left(\frac{Pr_h}{Pr_w} \right)^n$

$$n = \begin{cases} 0 & \text{for gases} \\ \frac{1}{4} & \text{for liquids} \end{cases}$$

c_2 and m given in Table 8-5

Flow across tube bundles for $0.7 < Pr < 500$ and $N \geq 20$

(8-98) $Nu_N = c_3 Nu_{N \geq 20}$
Correction factor c_3 is given in Fig. 8-12

To correct Nu_m given by Eq. (8-97) for tube bundles having $1 \leq N \leq 20$

(8-99) $\Delta P = f \frac{NG_{max}^2}{2\rho} Z$

f and Z are given in Figs. 8-13 and 8-14.

Pressure drop for flow across tube bundles

(8-100) $Nu_m = 4.03 + 0.228 (Re Pr)^{0.7}$

Mercury flow across a staggered, equilateral tube arrangement; $20,000 < Re < 80,000$

Table A.3 Thermophysical Properties of Common Materials^a*Structural Building Materials*

DESCRIPTION/COMPOSITION	TYPICAL PROPERTIES AT 300 K		
	DENSITY, ρ (kg/m ³)	THERMAL CONDUCTIVITY, k (W/m · K)	SPECIFIC HEAT, c_p (J/kg · K)
Building Boards			
Asbestos-cement board	1,920	0.58	—
Gypsum or plaster board	800	0.17	—
Plywood	545	0.12	1,215
Sheathing, regular density	290	0.055	1,300
Acoustic tile	290	0.058	1,340
Hardboard, siding	640	0.094	1,170
Hardboard, high density	1,010	0.15	1,380
Particle board, low density	590	0.078	1,300
Particle board, high density	1,000	0.170	1,300
Woods			
Hardwoods (oak, maple)	720	0.16	1,255
Softwoods (fir, pine)	510	0.12	1,380
Masonry Materials			
Cement mortar	1,860	0.72	780
Brick, common	1,920	0.72	835
Brick, face	2,083	1.3	—
Clay tile, hollow			
1 cell deep, 10 cm thick	—	0.52	—
3 cells deep, 30 cm thick	—	0.69	—
Concrete block, 3 oval cores			
sand/gravel, 20 cm thick	—	1.0	—
cinder aggregate, 20 cm thick	—	0.67	—
Concrete block, rectangular core			
2 cores, 20 cm thick, 16 kg	—	1.1	—
same with filled cores	—	0.60	—
Plastering Materials			
Cement plaster, sand aggregate	1,860	0.72	—
Gypsum plaster, sand aggregate	1,680	0.22	1,085
Gypsum plaster, vermiculite aggregate	720	0.25	—

Table A.3 Continued
Insulating Materials and Systems

DESCRIPTION/COMPOSITION	TYPICAL PROPERTIES AT 300 K		
	DENSITY, ρ (kg/m ³)	THERMAL CONDUCTIVITY, k (W/m·K)	SPECIFIC HEAT, c_p (J/kg·K)
Blanket and Batt			
Glass fiber, paper faced	16	0.046	—
	28	0.038	—
	40	0.035	—
Glass fiber, coated; duct liner	32	0.038	835
Board and Slab			
Cellular glass	145	0.058	1,000
Glass fiber, organic bonded	105	0.036	795
Polystyrene, expanded	55	0.027	1,210
		0.040	1,210
		0.049	—
Mineral fiberboard; roofing material	265	0.049	—
Wood, shredded/cemented	350	0.087	1,590
Cork	120	0.039	1,800
Loose Fill			
Cork, granulated	160	0.045	—
Diatomaceous silica, coarse powder	350	0.069	—
		0.091	—
		0.052	—
Diatomaceous silica, fine powder	275	0.061	—
		0.043	835
Glass fiber, poured or blown	16	0.043	835
Vermiculite, flakes	80	0.068	835
	160	0.063	1,000
Formed/Foamed-in-Place			
Mineral wool granules with asbestos/inorganic binders, sprayed	190	0.046	—
Polyvinyl acetate cork mastic; sprayed or troweled	—	0.100	—
Urethane, two-part mixture; rigid foam	70	0.026	1,045
Reflective			
Aluminum foil separating fluffy glass mats; 10–12 layers; evacuated; for cryogenic application (150 K)	40	0.00016	—
Aluminum foil and glass paper laminate; 75–150 layers; evacuated; for cryogenic application (150 K)	120	0.000017	—
Typical silica powder, evacuated	160	0.0017	—

*Adapted from References 1, 2, 13.

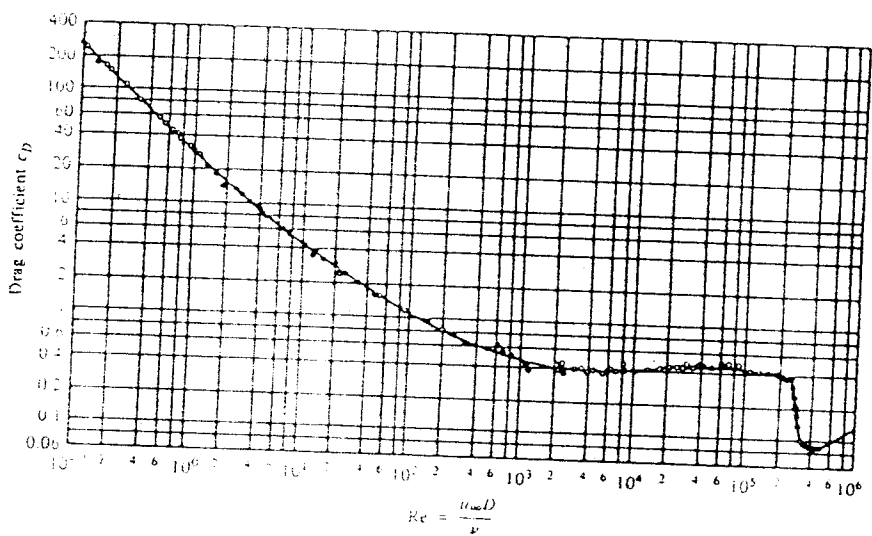

Drag coefficient for flow over a single sphere. (From Schlichting [3].)

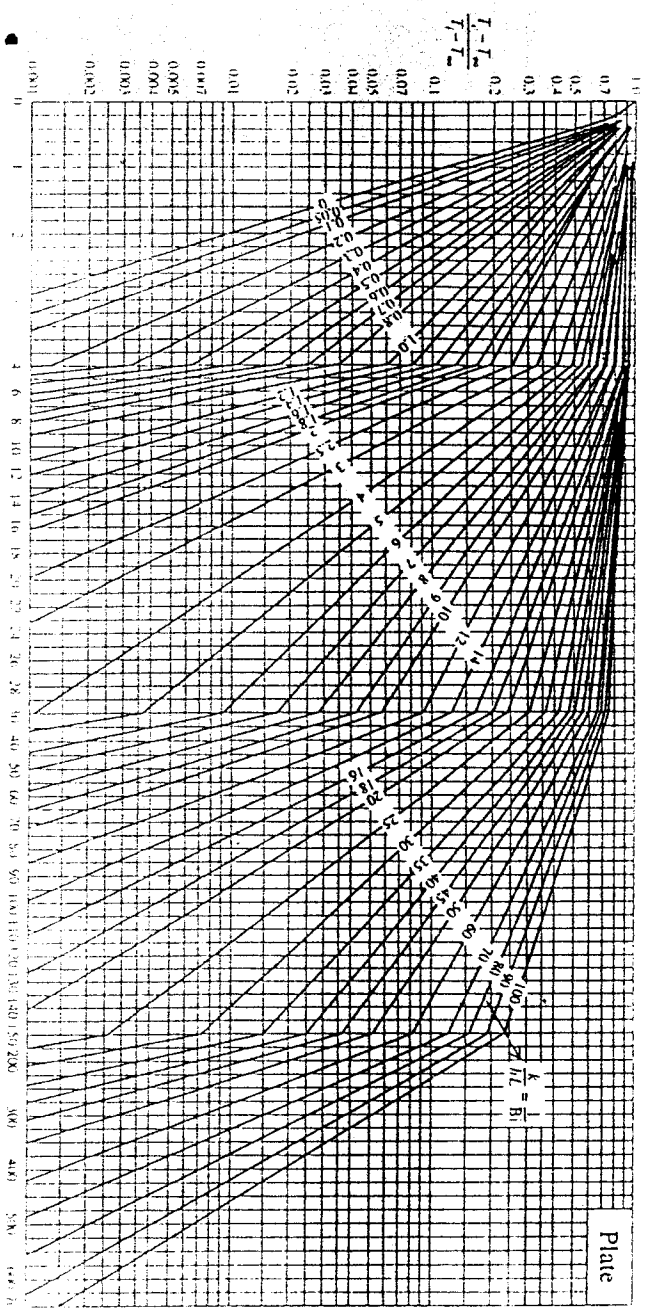

$$\frac{\partial T}{\partial x} = Fo \frac{\partial T}{\partial x}$$

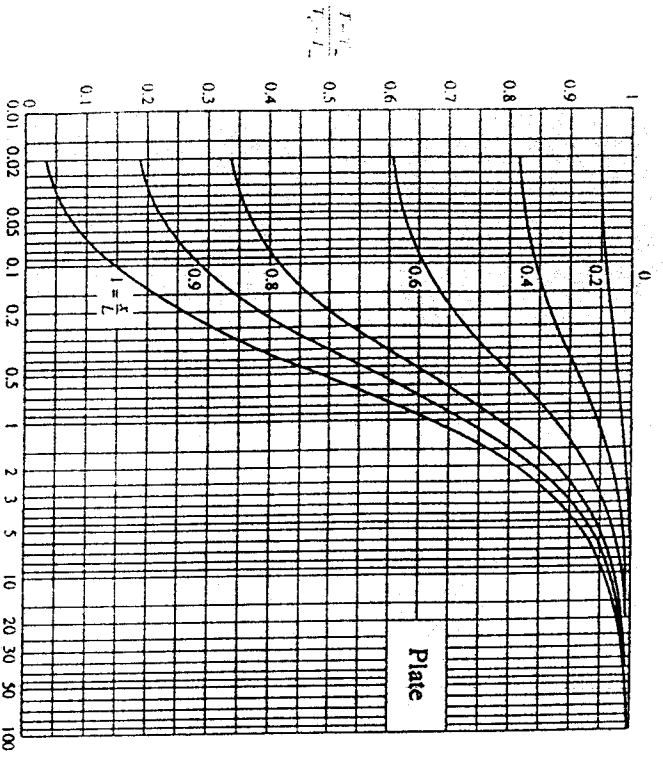

Plate

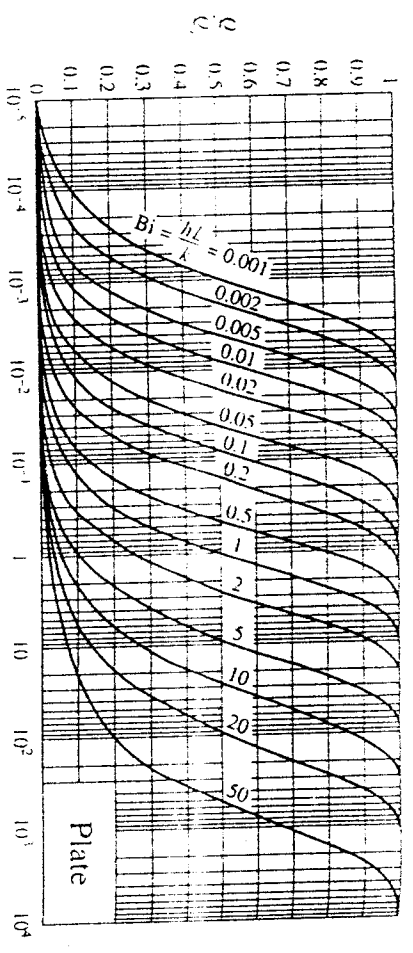

Plate

$$\frac{h^2}{k^2} \alpha t = Bi^2 Fo$$

B

PHYSICAL PROPERTIES

Table B-1 Physical properties of gases at atmospheric pressure

T, K	ρ , $\frac{\text{kg}}{\text{m}^3}$	c_p , $\frac{\text{kJ}}{\text{kg}\cdot^\circ\text{C}}$	μ , $\frac{\text{kg}}{\text{m}\cdot\text{s}}$	ν , $\frac{\text{m}^2}{\text{s}}$ $\times 10^6$	k , $\frac{\text{W}}{\text{m}\cdot\text{K}}$	α , $\frac{\text{m}^2}{\text{s}}$ $\times 10^4$	Pr
Air							
100	3.6010	1.0266	0.6924×10^{-5}	1.923	0.009246	0.02501	0.770
150	2.3675	1.0099	1.0283	4.343	0.013735	0.05745	0.753
200	1.7684	1.0061	1.3289	7.490	0.01809	0.10165	0.739
250	1.4128	1.0053	1.488	9.49	0.02227	0.13161	0.722
300	1.1774	1.0057	1.683	15.68	0.02624	0.22160	0.708
350	0.9980	1.0090	2.075	20.76	0.03003	0.2983	0.697
400	0.8826	1.0140	2.286	25.90	0.03365	0.3760	0.689
450	0.7833	1.0207	2.484	28.86	0.03707	0.4222	0.683
500	0.7048	1.0295	2.671	28.86	0.04038	0.5564	0.680
550	0.6473	1.0392	2.848	44.34	0.04360	0.6532	0.680
600	0.5879	1.0551	3.018	51.34	0.04659	0.7512	0.680
650	0.5430	1.0635	3.177	58.51	0.04953	0.8578	0.682
700	0.5030	1.0735	3.332	66.25	0.05230	0.9672	0.684
750	0.4709	1.0836	3.481	73.91	0.05509	1.0774	0.686
800	0.4405	1.0978	3.625	82.29	0.05779	1.1951	0.689
850	0.4149	1.1095	3.765	90.75	0.06028	1.3097	0.692
900	0.3925	1.1212	3.899	99.3	0.06279	1.4271	0.696
950	0.3716	1.1331	4.023	108.2	0.06525	1.5510	0.699
1000	0.3524	1.1447	4.152	117.8	0.06752	1.6779	0.702
1100	0.3204	1.160	4.44	138.6	0.0732	1.969	0.704
1200	0.2947	1.179	4.69	159.1	0.0782	2.251	0.707
1300	0.2747	1.197	4.93	182.1	0.0837	2.583	0.705
1400	0.2585	1.214	5.17	205.5	0.0891	2.920	0.705
1500	0.2455	1.230	5.40	229.1	0.0946	3.262	0.705
1600	0.2341	1.248	5.63	254.5	0.100	3.609	0.705
1700	0.2262	1.267	5.85	280.5	0.105	3.977	0.705

Table B-1 (continued)

T, K	ρ , $\frac{\text{kg}}{\text{m}^3}$	c_p , $\frac{\text{kJ}}{\text{kg}\cdot^\circ\text{C}}$	μ , $\frac{\text{kg}}{\text{m}\cdot\text{s}}$	ν , $\frac{\text{m}^2}{\text{s}}$ $\times 10^6$	k , $\frac{\text{W}}{\text{m}\cdot\text{K}}$	α , $\frac{\text{m}^2}{\text{s}}$ $\times 10^4$	Pr
Air							
1800	0.1970	1.287	6.07	308.1	0.111	4.379	0.704
1900	0.1858	1.309	6.29	338.5	0.117	4.811	0.704
2000	0.1762	1.338	6.50	369.0	0.124	5.260	0.702
2100	0.1682	1.372	6.72	399.6	0.131	5.715	0.700
2200	0.1602	1.419	6.93	432.6	0.139	6.120	0.707
2300	0.1538	1.482	7.14	464.0	0.149	6.540	0.710
2400	0.1458	1.574	7.35	504.0	0.161	7.020	0.718
2500	0.1394	1.688	7.57	543.5	0.175	7.441	0.730
Helium							
3	1.4657	5.200	8.42×10^{-7}	50.2	0.0106	0.04625	0.74
33	3.799	5.200	125.5	37.11	0.0928	0.5275	0.70
144	0.2435	5.200	156.6	64.38	0.1177	0.9288	0.694
200	0.1906	5.200	181.7	95.50	0.1357	1.3675	0.70
255	0.13780	5.200	230.5	173.6	0.1691	2.449	0.71
366	0.10204	5.200	275.0	269.3	0.197	3.716	0.72
477	0.08282	5.200	311.3	375.8	0.225	5.215	0.72
589	0.07032	5.200	347.5	494.2	0.251	6.661	0.72
700	0.06023	5.200	381.7	634.1	0.275	8.774	0.72
800	0.05286	5.200	413.6	781.3	0.298	10.834	0.72
Carbon dioxide							
220	2.4733	0.783	11.105×10^{-6}	4.990	0.010805	0.05920	0.818
250	2.1657	0.804	12.590	5.813	0.012884	0.07401	0.793
300	1.7973	0.871	14.958	8.321	0.016572	0.10588	0.770
350	1.5362	0.900	17.205	11.19	0.02047	0.14808	0.755
400	1.3424	0.942	19.32	14.39	0.02461	0.19463	0.738
450	1.1918	0.980	21.34	17.90	0.02897	0.24813	0.721
500	1.0732	1.013	23.26	21.67	0.03352	0.3084	0.702
550	0.9739	1.047	25.08	25.74	0.03821	0.3750	0.685
600	0.8938	1.076	26.83	30.02	0.04311	0.4483	0.668
Carbon monoxide							
220	1.55363	1.0429	13.832×10^{-6}	8.903	0.01906	0.11760	0.758
250	1.3649	1.0425	15.40	11.28	0.02144	0.15063	0.750
300	1.13876	1.0421	17.843	15.67	0.02525	0.21280	0.737
350	0.97425	1.0434	20.09	20.62	0.02883	0.2836	0.728
400	0.85363	1.0484	22.19	25.99	0.03226	0.3605	0.722
450	0.75848	1.0551	24.18	31.88	0.036	0.4439	0.718

THE UNIVERSITY OF ZAMBIA
SCHOOL OF ENGINEERING
DEPARTMENT OF MECHANICAL ENGINEERING

UNIVERSITY SEMESTER I EXAMINATIONS - MARCH, 1998

ME 571 - VIBRATIONS AND CONTROL ENGINEERING

TIME: THREE (3) HOURS CLOSED BOOK

INSTRUCTIONS: -ANSWER FOUR (4) QUESTIONS ONLY
-TWO (2) QUESTIONS MUST BE ANSWERED FROM EACH SECTION
-ALL QUESTIONS CARRY EQUAL MARKS

SECTION A - CONTROL ENGINEERING

USE A SEPARATE ANSWER BOOKLET FOR THIS SECTION.
ANSWER ANY TWO (2) QUESTIONS ONLY.

QA-1 The feed forward transfer ratio given by

$$G(D) = \frac{1}{D^2 + 6D + 8}$$

is proportionally controlled (gain factor K) in a negative feedback loop which contains a proportional feedback element $K_p = 0.25$.

- (i) Calculate the poles of the controlled system and draw the root locus. [8 marks]
- (ii) Determine the values of K for which the controlled system is stable. [2 marks]
- (iii) For $K=68$, determine:
- (a) the damping
 - (b) the undamped natural frequency
 - (c) the damped natural frequency [6 marks]

- (iv) Determine the value of K for which the overshoot equals 25%. [4 marks]
 The proportional controller K is now replaced by a controller

$$K_+ = \frac{K}{D+6}$$

- (v) Sketch the root locus of this controlled system. [2 marks]
 (vi) Determine the values of K for which the controlled system is stable, either by applying Routh's stability criterion or by considering the sketch of (v)

[3 marks]

QA-2 A process, determined by the transfer ratio

$$H(D) = \frac{y}{x} = \frac{2D+1}{D^2+9D-10}$$

is at rest for $t < 0$ s (with $y = 0$ for $t < 0$ s).
 At $t = 0$ s the system is subjected to a unit impulse input.

- (i) Determine the response for $t \geq 0$ s. [10 marks]
 (ii) Draw the response for $0 \leq t \leq 4$ s. [10 marks]
 (iii) Explain the shape of the response. [5 marks]

QA-3 Given are three transfer functions

$$H_1(D) = 8D+1$$

$$H_2(D) = \frac{1}{6D}$$

$$H_3(D) = \frac{1}{10D+2}$$

For the system with transfer ratio

$$H(D) = H_1(D) \cdot H_2(D) \cdot H_3(D),$$

- (i) sketch the bode diagrams for the amplitude ratio (asymptotes only) and the phase angle; [14 marks]

- (ii) determine the maximum angle by which the output is lagging or leading, and the corresponding circular frequency; [7 marks]
- (iii) indicate the values calculated under (ii) in the diagrams for the amplitude ratio and the phase angle. [4 marks]

SECTION B - VIBRATIONS

USE A SEPARATE ANSWER BOOKLET FOR THIS QUESTION.
ANSWER ANY TWO (2) QUESTIONS.

- QB-1 (a) In the analysis of the response of a damped system under the harmonic motion of the base, it can be shown that the motion of the mass relative to the base is given by

$$z(t) = Z \sin(\omega t - \phi)$$

Where

$$Z = \frac{r^2}{\sqrt{(1-r^2)^2 + (2\zeta r)^2}}$$

Show that the maximum value of the amplitude Z occurs when

$$r = \frac{1}{\sqrt{1-2\zeta^2}}$$

[10 marks]

- (b) An isolator pad is to be used to isolate vibrations from a milling machine with a rotating unbalance of 1.12 kg.m. The machine has a mass of 510 kg and operates at 1800 rpm. Tests on the isolator have shown that it has a stiffness of 5×10^6 N/m and a hysteretic damping coefficient of 0.4. As the vibration engineer, you have to advise the workshop foreman whether the foundation will require strengthening before installing the machine given that the design force for the foundation is 20 kN. What will your advice be and why?

[15 marks]

- QB-2 (a) Assuming that the phase angle is zero, show that the response, $x(t)$, of an under-damped single degree of freedom system reaches a maximum value when

$$\sin \omega_d t = \sqrt{1-\zeta^2}$$

[10 marks]

- (b) An under-damped shock absorber is to be designed for a motorcycle of mass 200 kg (Figure QB-2a). When the shock absorber is subjected to an initial vertical velocity due to a road bump, the resulting displacement time curve is as shown in Figure QB-2b. Find the necessary stiffness and damping constants of the shock absorber if the damped period of vibration is to be 2sec and the amplitude is to be reduced to $\frac{1}{4}$ in one half cycle.

[15 marks]

- QB-3 The mass of the anvil and frame of the forging hammer shown in Figure QB-3 is 200kg. The mass of the foundation block is 250 kg and the stiffness of the elastic pad placed between the anvil and the foundation block is 150 MN/m². If the stiffness of the isolation placed underneath the foundation (including the elasticity of the soil) is 75 MN/m², find the natural frequencies and the mode shapes of the system. Comment on the movement of the system at each of its natural frequencies.

[25 marks]

END OF EXAMINATION - ME 571
Ir. H.A. de Keyzer and Dr. A.N. Ng'andu

Laplace transform pairs

$f(t)$	$F(s)$	$f(t)$	$F(s)$
$u_1(t)$	1	$t^n e^{at}$	$\frac{n!}{(s-a)^{n+1}}$
$u(t)$	$\frac{1}{s}$	$\sin \omega t$	$\frac{\omega}{s^2 + \omega^2}$
t	$\frac{1}{s^2}$	$\cos \omega t$	$\frac{s}{s^2 + \omega^2}$
e^{at}	$\frac{1}{s-a}$	$e^{at} \sin \omega t$	$\frac{\omega}{(s-a)^2 + \omega^2}$
t^n	$\frac{n!}{s^{n+1}}$	$e^{at} \cos \omega t$	$\frac{s-a}{(s-a)^2 + \omega^2}$

Laplace transform properties

Time function	Laplace transform
$kf(t)$	$kF(s)$
$f_1(t) \pm f_2(t)$	$F_1(s) \pm F_2(s)$
$f'(t)$	$sF(s) - f(0)$
$f''(t)$	$s^2F(s) - sf(0) - f'(0)$
$f^{(n)}(t)$	$s^n F(s) - s^{n-1}f(0) - \dots - f^{(n-1)}(0)$
$f^{(-1)}(t)$	$\frac{F(s)}{s} + \frac{f^{(-1)}(0)}{s}$
$f^{(-n)}(t)$	$\frac{F(s)}{s^n} + \frac{f^{(-1)}(0)}{s^{n-1}} + \dots + \frac{f^{(-n)}(0)}{s}$
$f(at)$	$\frac{1}{a} F\left(\frac{s}{a}\right)$
$e^{at}f(t)$	$F(s-a)$
$t^n f(t)$	$(-1)^n \frac{d^n}{ds^n} F(s)$
$f(\tau) = f(t-t_0)$	$e^{-st_0} F(s)$
$\int_0^t f(\lambda)g(t-\lambda) d\lambda$	$F(s)G(s)$

ME 571 - VIBRATIONS AND CONTROL ENGINEERING

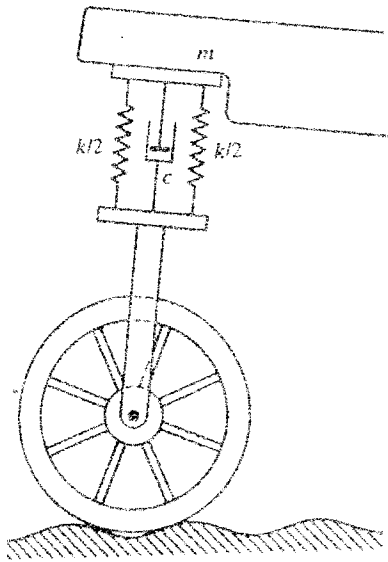

Figure QB-2a

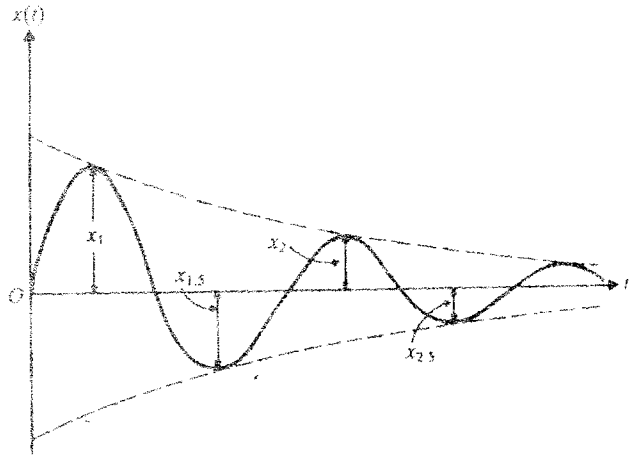

Figure QB-2b

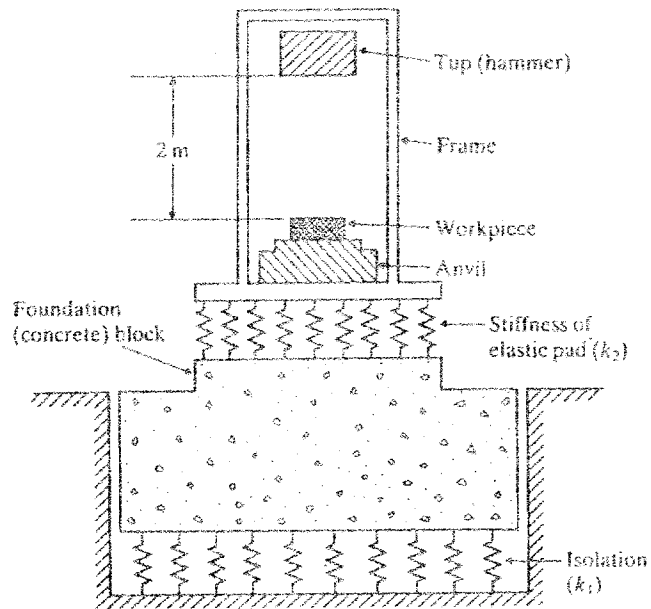

Figure QB-3

THE UNIVERSITY OF ZAMBIA
UNIVERSITY EXAMINATIONS - 1998

SE 321 - CARTOGRAPHY I

Time: Three hours

Answer: All questions in Part A and one in Part B

Part A

1. Explain briefly the following cartographic terms:
a) Orthogonal projection, b) Scribing, c) Serif, d) False origin,
e) Grid declination, f) Neat lines, g) Conformal projection, h) Master grid,
i) Principal scale, j) Rhumb line.

(20)

2. a) What projection is used for national topographic mapping and cadastral surveys in Zambia?
b) What are the properties of this projection?
c) What two different grid systems are used for national topographic mapping and cadastral surveys in Zambia?
d) Why is the grid system for national mapping not suitable for cadastral surveys?

(2+6+2+5)

3. In cartographic fair drawing certain essential requirements should be met.
a) Which of these are the requirements for drawings?
b) Which are the general requirements for drawing inks?
c) What are the advantages of scribing over ink drawing?

(5+5+5)

4. a) What different cadastral plans exist in Zambia?
b) By which rules are they governed?
c) Explain briefly, how these plans differ from each other from the cartographic point of view.

(3+4+8)

5. a) Where and when was the oldest map ever found on Earth made?
b) What is the basis of the so called modern mapping and when was it started in Zambia?
c) What are the scales of the main national topographic maps produced by Zambian Survey Department?

(3+6+6)

cont...

Part B

1. It is often necessary to include a declination diagram indicating three different norths when compiling a map;
 - a) What is the importance of this declination diagram to a map user?
 - b) Explain the difference between these three north directions.
 - c) Draw such a declination diagram showing these three different north directions and label all the angular values.
 - d) Assuming you are given a map printed in 1970 with its declination diagram showing the following parameters;
 - Grid declination = $0^{\circ} 35'$
 - Magnetic declination = $8^{\circ} 15'$

Determine the Total Correction at the time of map printing.

- e) Supposing the annual change for the map given in (d) was 2' W from 1970 to 1980 and then changed to 1' E from 1981 to date, calculate the grid (map) back bearings which would define the location on the map of a terrain feature when the observed field bearings from this feature to two known Control Points ZP 205 and ZP 67 are $319^{\circ} 45'$ and $73^{\circ} 15'$ respectively.

(3+3+3+1+10)

2. A surveyor has surveyed a lot of ABCD and got the coordinates as indicated in the following list:

	Y	X
A.	78 390.30 m	30 678.40 m
B.	78 324.15	30 697.90
C.	78 330.00	30 769.95
D.	78 411.85	30 752.80

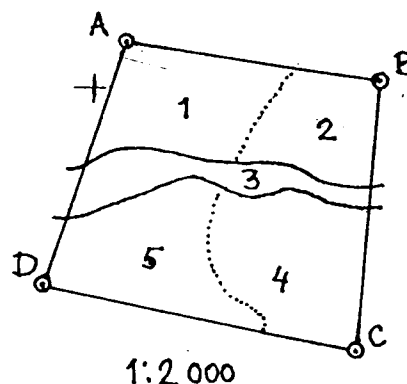

The sub-areas 1-5 of the lot have also been surveyed and a map at scale of 1:2000 has been drawn as indicated in the diagram above.

- a) Calculate the area of the lot.
- b) Describe how you would perform the measurements of the sub-areas 1-5 with a planimeter.
- c) What size of the drawing sheet would you recommend for this plot?
- d) Make a rough lay-out for this drawing indicating spaces for the stand, margins, heading and all other necessary information in a generalised way.

(6+7+2+5)

**University of Zambia
School of Engineering
Department of Surveying
Box 32379, Lusaka**

**Final examinations - September 1998
SE 332 - Photogrammetry I**

Instructions

Time: Three (3) hours

Answer ALL questions from section A and Only ONE from section B

Section A

1. (a) Explain the meaning of the following terms;
 - rectification
 - flying height
 - crab angle
 - base/height ratio
 - scheimpflug condition
 - dead ground

(b) With the help of well-labeled diagrams, describe the five (5) major lens aberrations that affect image quality.

(c) What is the required incident angle that should produce absolute reflection in water if the light ray is coming from a glass media, given that the refractive index of glass is 1.66 and the ratio of the refractive index of water to that of air is 1.33.

(6 + 15 + 4)

2. (a) What are the main parts of an aerial camera, for each part give the main function?

(b) What are the five major steps involved in processing of black and white film.

(c) Describe the process of producing orthophotos in both flat and hilly terrain. Also discuss the differences in the processes used above giving examples where possible.

(10 + 10 + 5)

3. An exposure meter reading indicates that in order to obtain a correct exposure time for a particular film the diaphragm setting should be $f/8$ and the shutter speed should be $1/60s$. If an object is to be photographed at (a) half the natural size (b) natural size (c) twice the natural size, calculate;
the shutter speed setting required to give the correct exposure in each case **(25)**

Section B

4. (a)
- (i) Explain the term depth of perception with respect to stereoscopic viewing.
- (ii) Given that the elevation of point C is 200m above MSL and that the parallax reading for the same point is 11.89mm and that of point A is 10.96mm, the parallax constant is 80.71mm. Calculate the parallax difference between the two points and the elevation of point A if the flying height for a pair of photos is 1000m.
- (b) A mapping project is designed to use aerial photography at a scale of 1:10000 for a preliminary design of a development project covering an area of 20 x 15km. If a 15/23 camera is used with end and side overlaps of 60% and 30% respectively, calculate the following parameters if a flight plan along the longer side of the project boundary is to be prepared at a map of scale of 1:20,000;
- (i) total number of flight lines
- (ii) total number of photographs to cover the project area
- (iii) spacing between boundaries and extreme flight lines close to the boundary
- (iv) total number of models
- (v) the required intervalometer setting that will achieve the desired end lap if the aircraft speed is 300km/h
- (15+ 10)
5. (a) Explain the following terms;
- (i) planimetric control
- (ii) photographic properties of film
- (iii) metric photogrammetry
- (b) Derive from first principles the equation for correction of earth curvature. Use a well-labeled diagram to support your derivation.
- (c) Explain the concept of false (infrared) colour photography with special reference to the composition of the film. Give the main advantages and disadvantages of false colour photography and mention at least two major applications where it is widely used.

(6 + 9 + 10)

*****GOOD LUCK*****



School of Engineering
Department of Surveying
SE 371 –Methods and Principles of Surveying I
Final Examination-March 1998

Time: 3 Hours Answer Any Four Questions All Questions Carry Equal Marks

Question 1(12+6+7)

Two ground control points A and B (fig 1) have the following coordinates:

	E	N
A	285.00	320.00
B	302.50	390.00

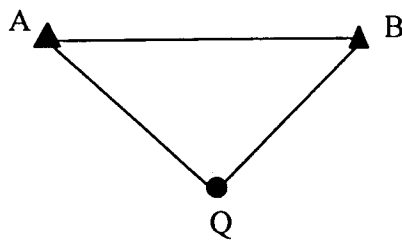

Fig 1

A tacheometer was set up at station A and B and the following information booked:

Station	Staff Station	Horizontal Reading	Elevation Angle	Stadia Readings		
				L	M	U
A	B	00° 00'				
	Q	25° 15'	-02°00'	1.000	a ₁	a ₂
B	A	00° 00'				
	Q	315° 31'	03°00'	1.000	b ₁	b ₂

Multiplication and additive constants of the instrument are 100 and 0 respectively.

- (a) Estimate the values of a₁, a₂, b₁ and b₂ obtained on vertically held staff.
- (b) Compute the coordinates of Q.
- (c) If the reduced level of a point A is 200.00 m and the height of the instrument is 1.5m, what is the reduced level of point Q?

Question 2 (5+20)

(a) (i) Mention two common methods of single point determination.

(ii) List three principal axes of a theodolite

(b) In order to determine the position of the point P, directions were observed from this point to three control points A, B, C with a theodolite as follows:

To point	Direction
A	163° 19' 42"
B	224° 08' 16"
C	108° 46' 07"

The coordinates of control points are:

Point	E(m)	N(m)
A	2771.97	8001.36
B	2936.41	8191.44
C	2961.26	7872.01

Compute the coordinates of point P.

Question 3 (25 marks)

An invar reference tape was standardised in the flat at 20°C with a tension of 100 N and was found to be 30.0073 in length. The first bay of a triangulation base line was measured in catenary using the reference tape and then with an invar field tape at a temperature of 15°C and with a tension of 100N, the two measurements were 29.8189m and 29.8332m respectively. The second bay of the baseline was measured in catenary using the field tape at 13°C and 100 N and the resulting value was 29.9349 m.

Given

- the coefficient of expansion for invar = 5.4×10^{-7} per °C
- the mass of tape = 0.0123kg/m
- the inclination of the second bay = $3^{\circ} 50'$
- the mean height of the second bay 1250 m above msl
- radius of earth = 6371 km

Calculate the horizontal length of the second bay reduced to mean sea level.

Question 4 (5+12+8)

- (a) What is meant by 'levelling from the middle' and what are its advantages?
- (b) The following figures were extracted from a level field book that was soaked by the rain. As such some entries were not so legible.

BS	IS	FS	HI	RL	Remarks
1.43			1279.08	1277.65	BM
	?			1277.07	
	?			1278.07	
3.37		?	?	1278.68	
	2.98			?	
	?			1280.07	
		0.68		?	TBM

- (i) Insert the missing figures and check your work.
- (ii) Assuming the reduced level of the TBM computed above is in error because the line of collimation was tilted upwards at an angle of $00^{\circ}06'$, compute its correct level if the back sight length was 100 m and the foresight length 60 m for each instrument setup.

Question 5 (10+10+5)

In order to determine coordinates of points 1 and 2 on site a traverse (fig 2) was run between X and Y and the following data was collected.

Stn.	Measured Angle	Line	Horizontal Distance (m)
X	104° 00' 30"	X-1	305.53
1	63° 20' 00"	1-2	359.69
2	258° 11' 00"	2-3	612.19
Y	120° 45' 00"		

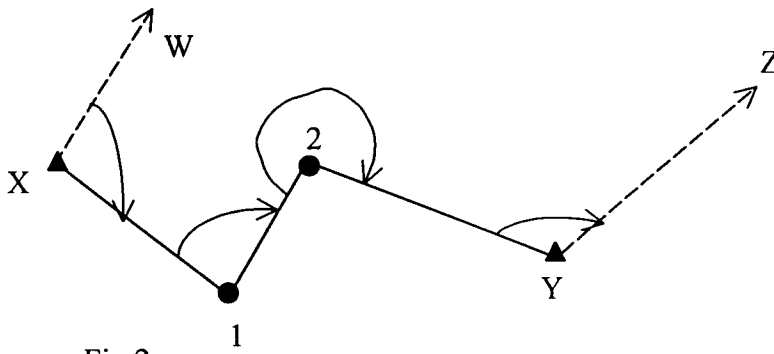

Fig 2

Given

Bearings	Coordinates	
	E (m)	N (m)
X-W = 43° 31' 30"	X 4321.404	6240.562
Y-Z = 49° 47' 15"	Y 5248.482	6091.871

Using Bowditch's method:

- Determine the angular misclosure and apply the necessary corrections.
- Compute the coordinates of point 1 and 2 showing all the adjustments
- State the relative accuracy.

..... Good Luck.....!

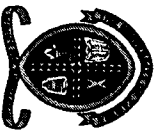

SE 371 Exam. Computation Sheet for Q 5 Comp.....

Stn No	Observed Angle	Corrected Bearing			Dist m	Co-ordinate differences						Co-ordinates			
		°	'	"		ΔE (m)	ΔN (m)	ΣE	ΣN	ΔE (m)	ΔN (m)	E (m)	N (m)		
W															
X	•	223	31	30										4321.404	6240.562
					305.53										
					359.69										
2				612.19											
Y													5248.482	6091.871	
Z															

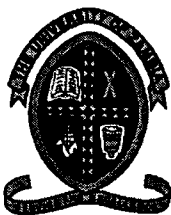

THE UNIVERSITY OF ZAMBIA
UNIVERSITY EXAMINATIONS
FIRST SEMESTER FINAL EXAMINATIONS MARCH '98
SE411 SURVEYING MATHEMATICS

Instructions

DURATION : THREE HOURS
ANSWER : ALL QUESTIONS IN SECTION A (70 MARKS) AND
ANY THREE QUESTIONS IN SECTION B (30 MARKS)
ATTACHMENTS : A STATISTICAL TABLE
TOTAL : 100 MARKS

SECTION A

QUESTION 1 (5+5+5+5+5)

A levelling network as indicated in the sketch is surveyed to determine the reduced levels (RL's) of the new benchmarks 112 and 118. It is required to adjust the network using the method of correlates (*observations only*).

Given heights

113	2.576 m
114	12.115 m
119	11.691 m
122	4.383 m

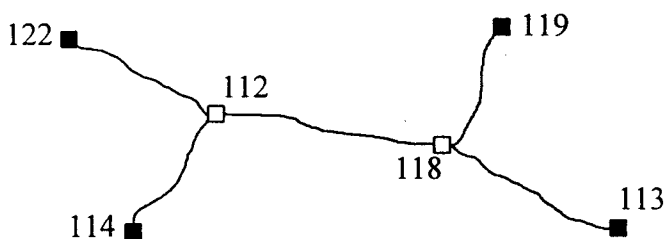

Observations

Nr	From	To	Height diff. (m)	Distance (km)
1	112	118	+7.253	2.0
2	119	118	-0.285	2.0
3	112	122	+0.225	1.0
4	112	114	+7.954	5.0
5	113	118	+8.833	2.5

The weights of the observations are inversely proportional to the distances.

- a. What is the number of redundancies in the network?
- b. Give the condition equations.
- c. Form the normal equations and solve them.
- d. Compute the residuals v_i for each observation.
- e. Compute the adjusted observations \hat{l} and the adjusted heights of the points 112 and 118.

QUESTION 2 (7+6+6+6)

The following design for a control network was drafted by a surveyor after a first reconnaissance of the area.

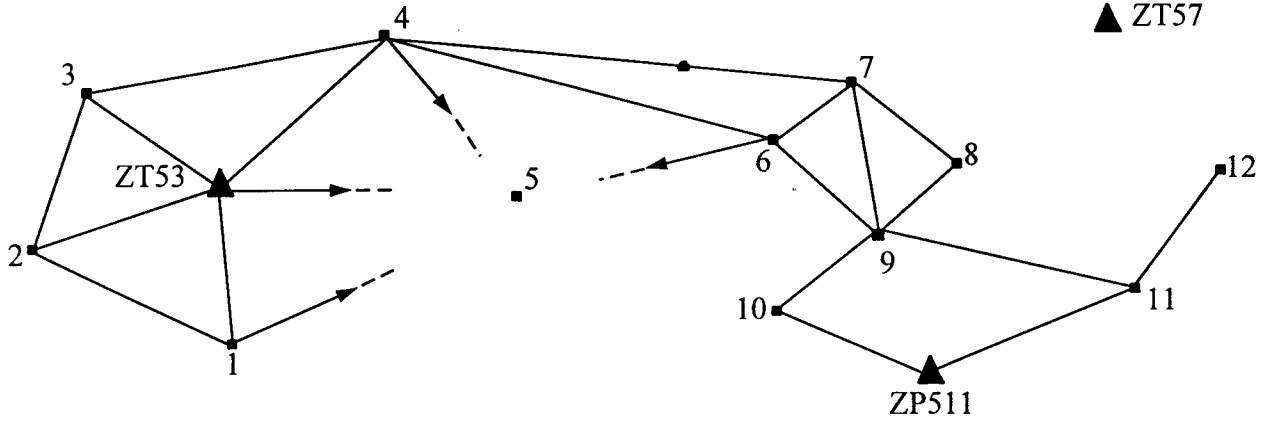

- Explain how you can analyse the precision of the unknown co-ordinates even before observations are made.
- What suggestions would you give to the surveyor in order to strengthen the above network and why?
- List the steps involved to adjust the network by *variation of co-ordinates*.
- Derive the linearised observation equation for a measured horizontal distance LAB.

QUESTION 3 (2+2+2+2+2)

Define the following terms:

- Precision
- Accuracy
- Error propagation
- Statistical hypothesis
- Error ellipse

QUESTION 4 (2+3+5)

- Why do we use Least Squares adjustment in surveying?
- Mention the three least squares techniques used in surveying.
- Give the formulae of the techniques mentioned in (c) and explain all the variables involved.

SECTION B

QUESTION 5 (5+5)

Given the following matrix: $A = \begin{bmatrix} -8 & 4 & -2 & 1 \\ 1 & 1 & 1 & 1 \\ 8 & 7 & 2 & 1 \\ -1 & 1 & -1 & 1 \end{bmatrix}$ and the vector $y = \begin{bmatrix} 1 \\ 1 \\ 1 \\ 1 \end{bmatrix}$

- Compute A^{-1} using Gauss reduction.
- Solve the set of equations $Ax = y$

QUESTION 6 (5+2+3)

An angle is measured 16 times with a theodolites. The measured values are:

- | | |
|----------------|-----------------|
| 1. 52° 35' 24" | 9. 52° 35' 24" |
| 2. 52° 35' 28" | 10. 52° 35' 29" |
| 3. 52° 35' 22" | 11. 52° 35' 35" |
| 4. 52° 35' 20" | 12. 52° 35' 31" |
| 5. 52° 35' 25" | 13. 52° 35' 29" |
| 6. 52° 35' 29" | 14. 52° 35' 26" |
| 7. 52° 35' 18" | 15. 52° 35' 30" |
| 8. 52° 35' 26" | 16. 52° 35' 31" |

It is suspected that the theodolite was disturbed between the eighth and the ninth measurements.

- Construct 90% confidence intervals for the means of the first eight and the last eight measurements.
- Is there evidence the theodolite was disturbed?
- Describe the three kind of errors that occur in survey measurements.

QUESTION 7 (5+5)

Plane co-ordinates X and Y of a survey station have a bivariate normal distribution. The mean and standard deviation of X are 1700.50 m and 0.20 m respectively; the mean and standard deviation of Y are 810.65 m and 0.10 m. The coefficient of correlation between X and Y is 0.60.

- Evaluate the principal dimensions of the error ellipse.
- Draw a nice sketch showing the orientation of the standard error ellipse associated with this survey station position.

FORMULAE FOR STANDARD POINT ERROR ELLIPSE

$$\sigma_x^2 = \frac{\sigma_x^2 + \sigma_y^2}{2} + \left[\frac{(\sigma_x^2 - \sigma_y^2)^2}{4} + \sigma_{xy}^2 \right]^{1/2}, \sigma_y^2 = \frac{\sigma_x^2 + \sigma_y^2}{2} - \left[\frac{(\sigma_x^2 - \sigma_y^2)^2}{4} + \sigma_{xy}^2 \right]^{1/2}$$

$$\tan 2\theta = \frac{2\sigma_{xy}}{\sigma_x^2 - \sigma_y^2}$$

QUESTION 8 (6+2+2)

- Define the following co-ordinate transformation methods and mention the parameters used: Helmert, Congruent and Affin.
- Normally, a Surveyor would prefer to use more common points for the determination of the transformation constants than necessary, why?
- Comment on the statement: "The more redundancy the better".

END OF QUESTIONS

M. Phiri, Dept. of Surveying

Table II. Percentiles of the Chi-Square Distribution

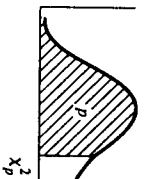

DEGREES OF FREEDOM	$\chi^2_{.99}$	$\chi^2_{.95}$	$\chi^2_{.90}$	$\chi^2_{.85}$	$\chi^2_{.80}$	$\chi^2_{.75}$	$\chi^2_{.70}$	$\chi^2_{.65}$	$\chi^2_{.60}$	$\chi^2_{.55}$	$\chi^2_{.50}$	$\chi^2_{.45}$	$\chi^2_{.40}$	$\chi^2_{.35}$	$\chi^2_{.30}$	$\chi^2_{.25}$	$\chi^2_{.20}$	$\chi^2_{.15}$	$\chi^2_{.10}$	$\chi^2_{.05}$	$\chi^2_{.025}$	$\chi^2_{.01}$	
1	.000	.000	.001	.004	.016	.064	.148																
2	.010	.020	.051	.103	.211	.446	.713																
3	.072	.115	.216	.352	.584	1.00	1.42																
4	.207	.297	.484	.711	1.06	1.65	2.20																
5	.412	.554	.831	1.15	1.61	2.34	3.00																
6	.676	.872	1.24	1.64	2.20	3.07	3.83																
7	.989	1.24	1.69	2.17	2.83	3.82	4.67																
8	1.34	1.65	2.18	2.73	3.49	4.59	5.53																
9	1.73	2.09	2.70	3.33	4.17	5.38	6.39																
10	2.16	2.56	3.25	3.94	4.87	6.18	7.27																
11	2.60	3.05	3.82	4.57	5.58	6.99	8.15																
12	3.07	3.57	4.40	5.23	6.30	7.81	9.03																
13	3.57	4.11	5.01	5.89	7.04	8.63	9.93																
14	4.07	4.66	5.63	6.57	7.79	9.47	10.8																
15	4.60	5.23	6.26	7.26	8.55	10.3	11.7																
16	5.14	5.81	6.91	7.96	9.31	11.2	12.6																
17	5.70	6.41	7.56	8.67	10.1	12.0	13.5																
18	6.26	7.01	8.23	9.39	10.9	12.9	14.4																
19	6.83	7.63	8.91	10.1	11.7	13.7	15.4																
20	7.43	8.26	9.59	10.9	12.4	14.6	16.3																
21	8.03	8.90	10.3	11.6	13.2	15.4	17.2																
22	8.64	9.54	11.0	12.3	14.0	16.3	18.1																
23	9.26	10.2	11.7	13.1	14.8	17.2	19.0																
24	9.89	10.9	12.4	13.8	15.7	18.1	19.9																
25	10.5	11.5	13.1	14.6	16.5	18.9	20.9																
26	11.2	12.2	13.8	15.4	17.3	19.8	21.8																
27	11.8	12.9	14.6	16.2	18.1	20.7	22.7																
28	12.5	13.6	15.3	16.9	18.9	21.6	23.6																
29	13.1	14.3	16.0	17.7	19.8	22.5	24.6																
30	13.8	15.0	16.8	18.5	20.6	23.4	25.5																
40	20.7	22.1	24.4	26.5	29.0	32.3	34.9																
50	28.0	29.7	32.3	34.8	37.7	41.4	44.3																
60	35.5	37.5	40.5	43.2	46.5	50.6	53.8																

$\chi^2_{.99}$	$\chi^2_{.95}$	$\chi^2_{.90}$	$\chi^2_{.85}$	$\chi^2_{.80}$	$\chi^2_{.75}$	$\chi^2_{.70}$	$\chi^2_{.65}$	$\chi^2_{.60}$	$\chi^2_{.55}$	$\chi^2_{.50}$	$\chi^2_{.45}$	$\chi^2_{.40}$	$\chi^2_{.35}$	$\chi^2_{.30}$	$\chi^2_{.25}$	$\chi^2_{.20}$	$\chi^2_{.15}$	$\chi^2_{.10}$	$\chi^2_{.05}$	$\chi^2_{.025}$	$\chi^2_{.01}$	
.455	1.07	1.64	2.71	3.84	5.02	6.63	7.88															
1.39	2.41	3.22	4.61	5.99	7.38	9.21	10.6															
2.37	3.66	4.64	6.25	7.81	9.35	11.3	12.8															
3.36	4.88	5.99	7.78	9.49	11.1	13.3	14.9															
4.35	6.06	7.29	9.24	11.1	12.6	15.1	16.7															
5.35	7.23	8.56	10.6	14.1	16.0	18.5	20.3															
6.35	8.38	9.80	12.0	14.1	17.5	20.1	22.0															
7.34	9.52	11.0	13.4	15.5	19.0	21.7	23.6															
8.34	10.7	12.2	14.7	16.9	19.0	21.7	23.6															
9.34	11.8	13.4	16.0	18.3	20.5	23.2	25.2															
10.3	12.9	14.6	17.3	19.7	21.9	24.7	26.8															
11.3	14.0	15.8	18.5	21.0	23.3	26.2	28.3															
12.3	15.1	17.0	19.8	22.4	24.7	27.7	29.8															
13.3	16.2	18.2	21.1	23.7	26.1	29.1	31.3															
14.3	17.3	19.3	22.3	25.0	27.5	30.6	32.8															
15.3	18.4	20.5	23.5	26.3	28.8	32.0	34.3															
16.3	19.5	21.6	24.8	27.6	30.2	33.4	35.7															
17.3	20.6	22.8	26.0	28.9	31.5	34.8	37.2															
18.3	21.7	23.9	27.2	30.1	32.9	36.2	38.6															
19.3	22.8	25.0	28.4	31.4	34.2	37.6	40.0															
20.3	23.9	26.2	29.6	32.7	35.5	38.9	41.4															
21.3	24.9	27.3	30.8	33.9	36.8	40.3	42.8															
22.3	26.0	28.4	32.0	35.2	38.1	41.6	44.2															
23.3	27.1	29.6	33.2	36.4	39.4	43.0	45.6															
24.3	28.2	30.7	34.4	37.7	40.6	44.3	46.9															
25.3	29.2	31.8	35.6	38.9	41.9	45.6	48.3															
26.3	30.3	32.9	36.7	40.1	43.2	47.0	49.6															
27.3	31.4	34.0	37.9	41.3	44.5	48.3	51.0															
28.3	32.5	35.1	39.1	42.6	45.7	49.6	52.3															
29.3	33.5	36.2	40.3	43.8	47.0	50.9	53.7															
39.3	44.2	47.3	51.8	55.8	59.3	63.7	66.8															
49.3	54.7	58.2	63.2	67.5	71.4	76.2	79.5															
59.3	65.2	69.0	74.4	79.1	83.3	88.4	92.0															

Reprinted with permission of Macmillan Publishing Co., Inc. from *Introduction to Probability and Statistics* by B. W. Lindgren and G. W. McElrath. Copyright © 1969 by B. W. Lindgren and G. W. McElrath. The table was adapted from Table VIII of *Biometrika Tables for Statisticians*.

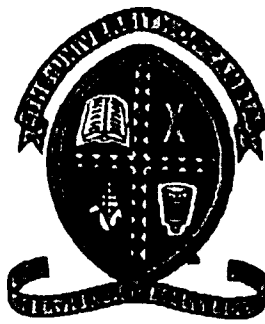

School of Engineering
Department of Surveying
UNIVERSITY EXAMINATIONS - February 1998

SE 422 - CARTOGRAPHY II

Time: **Three hours**

Answer: All questions in Part A and one in Part B

Part A

1. Explain briefly the following cartographic terms:
a) Threshold of perception, b) Grain, c) Flickering effect, d) Safelight,
e) Lithographic emulsion, f) Diazo reproduction, g) Proofing process,
h) Half-tone image, i) Offset printing, j) Drum plotter.
(20)

2. a) Which factors related to cartographic generalisation do you have to take into consideration in the map design process?
b) What are the reasons why optically reduced maps can not be used (in normal circumstances) for a new derived map without generalisation?
c) How does displacement relate to exaggeration in generalisation?
(7+4+4)

3. A reproduction unit is equipped with a vacuum frame (size A0), a process camera (size A0), a diazo copier (size A0) and a copyproof system (max. size A3). In stock there are wash-off and diazo materials as well as photographic copying materials and all necessary chemicals.
A customer has an ordinary printed map (size: 50 cm by 50 cm) and he needs a suitable copy for diazo copying at the customers map scale. Describe step by step what you should do to make the required copy?
(15)

4. Map revision requires a policy which takes into account the amount of changes and type of maps.
- Name three alternative revision policies.
 - Explain these policies briefly.
 - Give examples in which occasions different policies are practised.
- (3+6+6)

5.
 - Give four advantages and three disadvantages of computer assisted cartography over conventional methods?
 - Explain briefly the processes that are used to convert analogue map data to digital database?
- (7+8)

Part B

1. The selection of height information is an important part of topographic maps.
- Which are the different ways in which a cartographer can represent relief?
 - Explain briefly these different representations of relief.
- (8+12)
2. The smallest contour interval (A) for topographic maps may be determined to be the function of the scale denominator (M) of the map, the slope (α) and a certain constant k .
- Derive this correspondence.
 - In Zambia at 1: 50 000 topographic maps the contour interval of 20m has been chosen. Is this reasonable interval compared to the value given by (a)?
- (12+8)

END OF THE EXAMINATION

GOOD LUCK

THE UNIVERSITY OF ZAMBIA

UNIVERSITY EXAMINATIONS - MARCH 1998

SE 431 - PHOTOGRAMMETRY II

TIME: THREE HOURS

ANSWER: FOUR QUESTIONS

PART A - ALL QUESTIONS

PART B - ONE QUESTION

PART A

1.

- (a) Explain and show with figures the meaning of:
- exterior and relative orientation of photographs,
- absolute orientation of a photogrammetric model.
Define all parameters of the above orientations.

- (b) Write the mathematical models for determination of parameters of the above orientations and explain the general procedure for solution.

(10 + 15)

2.

- (a) Describe the main differences between optical projection and mechanical projection stereoplotters.
Why mechanical projection stereoplotters have been more commonly used than optical projection type ?

- (b) What is the difference between relative orientation by angular and single projector method executed with stereoplotters.
What type of stereoplotter can accommodate both methods of relative orientation and why ?

- (c) Photographs were taken with a 151.72 mm focal length camera and photo format 230 x 230 mm, at scale 1:10 000, with endlap of 60% .
Assuming a model scale for compilation with A8 stereoplotter as 1:5000, estimate the stereoplotter base and average projection distance.

(9 + 8 + 8)

3.

- (a) Why aerial triangulation is important in photogrammetric mapping technology ?



Semester I Examinations, March 1998
SE 462 – Remote Sensing

Instructions: Time allowed - 3hrs
Answer all questions in section A and only two(2) from section B

Section A:

Question A1 (5+5+5+5+5)

Define the following terms;

- (i) BIL & BSQ
- (ii) GAC & LAC
- (iii) Image registration
- (iv) SLAR
- (v) Training Sample

Question A2 (15)

Fill the required parameters in the table below;

Platform	No. of channels	Temporal resolution	Geometric resolution	Dynamic range	Sensor type(s)
NOAA 14					
LANDSAT 5					
SPOT XS					

Question A3 (10+5)

- (i) With the help of a well labeled diagram show what is meant by the term resampling. Give methods used in resampling together with advantages and disadvantages of each method.
- (ii) In geometric correction a first order polynomial equation (affine) is used in order to remove or reduce certain undesirable elements in the image. State the equation and give the reason why a minimum of three GCPs are used to solve for the unknowns.

Question A4 (15)

Show with the help of a diagram the working principle of the BOX classifier as used in image classification. Also give the main advantages and disadvantages of the above method.

Section B:

Question B1 (2+5+13)

- (i) What is the main difference between spatial and frequency domain filtering?
- (ii) What is the effect of increasing the filter matrix size on the processed (output) image? Use examples of 3x3, 5x5 and 7x7 filter sizes on a 9x9 image to amplify your answer.
- (iii) Apply the 5x5 median filter on the image below and show the pixel values of the filtered image. Use zeros (0s) in the areas not covered by the central pixel of the filter matrix.

0	1	2	3	4	5	6	7	8
1	6	5	4	3	2	1	0	7
2	5	2	3	4	5	6	1	6
3	4	3	3	4	5	5	2	5
4	3	4	4	2	4	4	3	4
5	2	5	5	4	3	3	4	3
6	1	6	5	4	3	2	5	2
7	0	1	2	3	4	5	6	1
8	7	6	5	4	3	2	1	0

Question B2 (20)

Classification of images depends on two main types of classification methods. Name the two methods used. For each method give the main algorithms commonly used, giving the advantages and disadvantages for each algorithm.

Question B3 (10+10)

- (i) The interaction of EM energy with the earth objects is what constitutes the main process of remote sensing. Describe the process of interaction of the energy from the source(s) to the earth objects until the energy is detected and recorded on the sensor(s).
- (ii) The success of classification is usually assessed the accuracy level attained. This is done by using a confusion or error matrix. Interpret the table below and give the *overall accuracy* of classification for the data shown;

		<i>Classifier Labeling</i>					
		Water	Forest	Urban	Bare soil	Grassland	Agriculture
<i>Reference Data Labeling</i>	Water	50	3	0	0	2	5
	Forest	4	62	3	0	0	1
	Urban	4	4	70	0	8	3
	Bare soil	0	0	0	64	0	0
	Grassland	3	0	2	0	71	1
	Agriculture	10	3	1	3	0	33

End of Exam, Good Luck!!!!

4. Map revision requires a policy which takes into account the amount of changes and type of maps.
- Name three alternative revision policies.
 - Explain these policies briefly.
 - Give examples in which occasions different policies are practised.
- (3+6+6)

5.
 - Give four advantages and three disadvantages of computer assisted cartography over conventional methods?
 - Explain briefly the processes that are used to convert analogue map data to digital database?
- (7+8)

Part B

1. The selection of height information is an important part of topographic maps.
- Which are the different ways in which a cartographer can represent relief?
 - Explain briefly these different representations of relief.
- (8+12)
2. The smallest contour interval (**A**) for topographic maps may be determined to be the function of the scale denominator (**M**) of the map, the slope (α) and a certain constant **k**.
- Derive this correspondence.
 - In Zambia at 1: 50 000 topographic maps the contour interval of 20m has been chosen. Is this reasonable interval compared to the value given by (a)?
- (12+8)

END OF THE EXAMINATION

GOOD LUCK

- (b) Describe briefly procedures for aerial triangulation by independent models. Assume both ways of formation of models; with stereoplotter and by analytical mean. Explain which of the above approaches should be recommended for accurate large scale digital mapping and why ?
- (c) How Global Positioning Systems do assist photogrammetric mapping ? What are the advantages of use of GPS in photogrammetry ?

(7 + 10 + 8)

PART B

- 4.
- (a) Derive the Y - parallax conditional equation for angular relative orientation of independent photos pair.
- (b) Assume the relative angular orientation parameters of two photos as:
- $$\begin{array}{lll} \varphi' = 2^{\circ} & \kappa' = - 3^{\circ} & \text{for left photo, and} \\ \omega'' = - 2^{\circ} & \varphi'' = - 1^{\circ} & \kappa'' = - 3^{\circ} \text{ for right photo,} \end{array}$$
- Using the derived equation in (4 a), calculate and show with figures the effect of the particular relative orientation parameters on photo parallax in six characteristic points 1 , 2, 3, 4, 5, 6 of photos pair, where points 1 and 2 are principal points of left and right photos (with the base distance equal to 90 mm) and points 3, 4, 5, 6, are located at 80 mm distance from the base (3, 6 up , 4, 5 down and 3, 4 on the left side and 5, 6 on right side of photo pair). The focal length (f) is equal to 150 mm.

(10 + 15)

- 5
- (a) What are the main principles of aerial triangulation by independent bundles ?
- (b) Assuming a block of 15 photographs in three runs (strips) with 35 tie points and 6 ground points (4 - XYZ, 2 - Z), shown in figure, evaluate the number of observational equations, number of unknowns and number of redundant observations, using aerial triangulation by independent bundles.

	. ○	.		.	●	.	○	
	
	.	. *		.		.	.	
	
 *	.	
	
	. ○	.		.		.	○	

- . tie point
- XYZ control point
- * Z control point

(10 + 15)

6

- (a) What are the basic principles of direct optical projection orthophoto systems ?
- (b) What are the differences between 'on' and 'off' line orthophoto systems ?
Is the electronic orthophoto system 'on' or 'off' line ?
- (c) What are the advantages and dis-advantages of orthophoto maps in comparison to conventional graphical maps ?

(9 + 8 + 8)

**END OF EXAMINATION
GOOD LUCK !**

University of Zambia
School of Engineering
 Department of Surveying

SE481 examination- March 1998

Time : 3 hours

Answer : Part A: Three questions for all the groups
 Part B: Civil Engineering Students Part B1
 Agric. Engineering students Part B2
 Geology students Part B3
 Soil Science students Part B4

PART A

Question 1

BP in their continued development plans are building a filling station at the new shopping mall opposite the show grounds. As engineer on site you are required to determine the volume to be excavated (shaded area) to put a tank 15m above the *datum*. To carry out this work you set up a grid of 20 by 20 m and carry out differential levelling as shown in the booking form below.

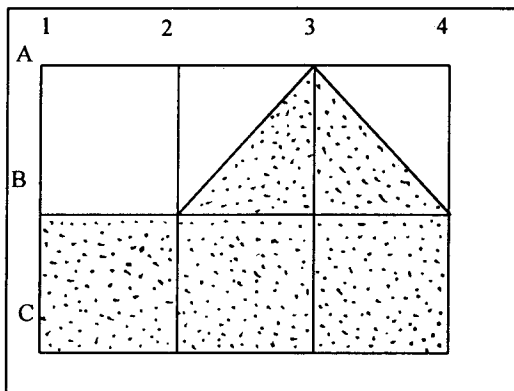

a) Complete the booking form with Rise and Fall method and compute the Reduced levels of the grid points

b) Estimate the volume of the shaded area to be excavated.

(10+15)

Pt. Nr	BS	IS	FS	Rise	Fall	Red. Lev.(m)	Rem
LS403	1.40					30.361	BM
A1		2.85					
2		2.07					
3		1.53					
4		0.64					
B1		2.50					
2		1.96					
3		1.19					
4		0.56					
C1	1.93		2.10				CP
2		1.22					
3		0.51					
4		0.15					
LS403			1.23			30.361	BM

Question 2

Lot 4037/M is a piece of land bordered by a stream on the north. A survey has been carried out to determine the area of this piece of land. The stream has been picked by carrying out an offset survey using line AB as the base. See Fig. below.

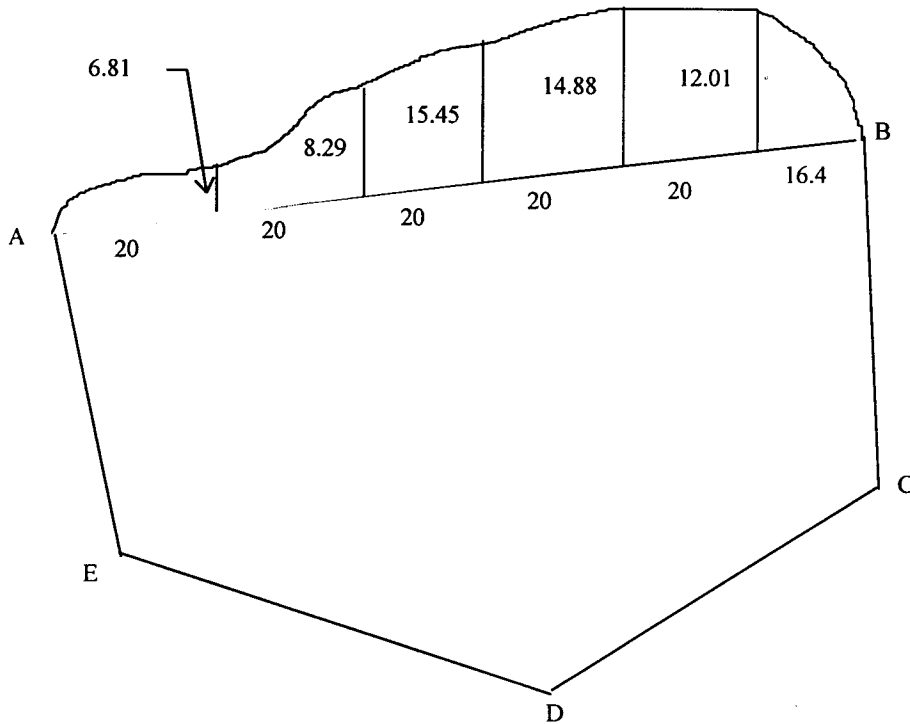

Given:

	Easting (m)	Northing(m)
A	110.2	220.4
B	225.4	239.1
C	219.2	75.2
D	167.3	43.4
E	121.3	60.4

Compute the area of the Lot .

(25 Marks)

Question 3

A traverse survey was carried out at which the field book contained the following readings

	@ A		Simple Mean	Reduced Mean
B	0°00'	180°00'		
1	308°40'	128° 42'		
	@ STN 1			
A	25° 20'	205° 20'		
2	256° 36'	76° 36'		

	@ <i>STN2</i>		Simple Mean	Reduced Mean
1	50°51'	230° 51'		
3	246° 44'	66° 44'		
	@ <i>STN3</i>			
2	100° 25'	280° 25'		
B	321° 09'	141° 09'		
	@ <i>STN B</i>			
3	8° 15'	180° 15'		
A	311° 41'	131° 41'		

The distance measurements were $d_{A1}=89.45\text{m}$ $d_{12}=80.71\text{m}$
 $d_{23}=61.59\text{m}$ $d_{3B}=81.59\text{m}$

The accuracy limit for this traverse is 1/1000

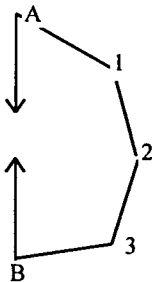

- Complete the booking form
- Find the angular misclosure and adjust the angles if necessary.
- compute the Fractional linear misclosure and state whether it is acceptable or not.

(5+10+10)

Question 4

A contour map is required where a road is planned. It is decided that a tacheometric survey be done using a theodolite and a staff.

Two points A and B are established in a local system

Point	Eastings(m)	Northings(m)	RL(m above MSL)
A	125.48	247.65	1265.074
B	274.61	235.44	1267.398

The instrument is set up at point A and the tacheometric readings were taken to a staff held vertically at detail points 1, 2, 3 etc.

Station A : Instrument Height : 1.58 m

Pt. Nr	Horiz. reading	Vertical reading	Stadia lines (m)
B	12° 30'		
1	62° 00'	85° 49' 30"	2.312/1.881/1.450
2	152° 30'	95° 05' 00"	2.385/1.881/1.376

Calculate

- The coordinates of target points 1 and 2 in the local coordinate system
- The horizontal distance between 1 and 2
- The RL's of 1 and 2.

(10+5+10)

End of Part A

Geology Students

Answer : All questions

Part B3- Geology Mapping

1. (a) What is a Geological map? (2 Marks)
 (b) Is there any difference between outcrop and exposure (2 marks)
 (c) What is the most important use of a topographic map in Geological mapping (1 mark)
 (d) State the features that a topographic map has. (4 marks)

2. (a) Name the 4 methods of mapping that may be used in both in Land Surveying and Geological mapping and comment on the accuracy of each method (4 marks)

(b) In a survey, the following data were acquired using an alidade and staff:

(i) Horizontal sighting

Station	DISTANCE ON THE STAFF HELD AT B BETWEEN LOWER AND UPPER STADIA (m)
A	-
B	0.5

Determine the horizontal distance between A and B. (1 mark)

(ii) Inclined sighting

Station	Distance on staff at Y between lower and upper stadia (m)	Angle of inclination of line of sight	Inclined distance from X and Y along line of sight (m)
X	-		
		+30°	
Y	0.7		150

Determine the horizontal distance and the vertical distance. (3 marks)

**THE UNIVERSITY OF ZAMBIA
B.ENG. SURVEYING**

UNIVERSITY EXAMINATIONS - MARCH 1998

SE 531 PHOTOGRAMMETRY III

**TIME: THREE HOURS
ANSWER: FOUR QUESTIONS**

**PART A: THREE QUESTIONS
PART B: ONE QUESTION**

PART A

1.

- (a) What are the main differences in principles of analogous, analytical and digital photogrammetry ?
- (b) What does mean image correlation ?
How is image correlation executed by a human operator and with electronic and digital image correlators in automated conventional analytical plotters and digital photogrammetric systems, respectively ?

(12 + 13)

2.

- (a) What are the main principles of conventional analytical plotter ?
- (b) What are the main differences between analogous computer supported stereoplotters, conventional analytical plotters and digital photogrammetric workstations ?

(12 + 13)

3.

- (a) Describe the requirements and procedures for photogrammetric compilation of digital large scale mapping.
What type of photogrammetric equipment and computer software will you recommend for aerial triangulation and map compilation to satisfy the required high accuracy ?
- (b) What photogrammetric approaches will you recommend for cadastral surveys in urban and rural areas in Zambia ?
Assuming the accuracy which is required in both cadastral systems, propose the optimal scale of aerial photography and other conditions to satisfy the required accuracy.

(13 + 12)

PART B

4.

- (a). What are the potentials of close range photogrammetry ?
- (b) Describe the systems used for recording objects in architectural and archeological applications.
- (c) What tasks can be solved by close range photogrammetry in architecture and archeology areas ?

(7 + 9 + 9)

5.

- (a) What are the main differences in methods for revision of large and medium scale maps ?
- (b) Medium scale map revision in Zambia and other African countries requires fast and economical methods to be used. Taking into consideration availability of various techniques, propose the most optimal ones and explain the reason of their selection.

(12 + 13)

6.

- (a) Explain the differences between optical and digital photographs. Describe shortly equipment used for their obtaining.
- (b) How GPS technology does assist photogrammetry ? Explain why GPS simplify and decrease considerably cost of photogrammetric compilation.

(10 + 15)

END OF EXAMINATION

GOOD LUCK !

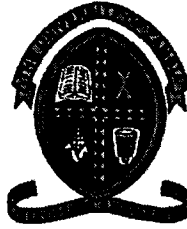

Department of Surveying
School of Engineering
University of Zambia

University Examination, First Semester Examination for 1996/98 SE 542 -Geodesy II

Time: 3 hours

All questions carry equal marks. Answer all questions from Part A and one question from Part B

PART A

Q1. (5 + 5 +5 +10)

- (a) Mention two methods of solving ellipsoidal triangles. Use figures to illustrate your answers.
- (b) Briefly describe how you could apply one of the above methods in solving a direct geodetic problem.
- (c) Show the relationship between the geodetic and geocentric latitude. Use a figure to depict the two latitudes.
- (d) Compute the length of an arc of latitude between two geodetic longitudes given the following:

$$\lambda_1 = 27^\circ 30' \text{ E}; \quad \lambda_2 = 28^\circ 00' \text{ E}$$

Latitude, ϕ , is -15° . The reference ellipsoid is Clarke 1880 (Mod.) with $f = 1/293.465$ and $a=6378249.145$

Q2. (10 +10 + 5)

- (a) Describe the behaviour of the satellite in terms of the following:
 - i. velocity at a height of 2000 km above the earth for a circular orbit
 - ii. velocity at a height of 20, 500 km above the earth for the same orbit

You are given that $GM = 3.986005 \times 10^5 \text{ km}^3 \text{ s}^{-1}$. Mean radius of the earth is 6371 km.

- (b) Based on (a) (ii), compute the period of the satellite as well as the mean motion. What are the determining parameters for the two quantities you have just computed?

(c) List the four possible orbits for a satellite. Illustrate using with a figure.

Q3. (3 + 7 + 3 +12)

(a) List three main or common applications of gravity anomalies in geodesy.

(b) What do you understand by gravity reductions. What is the usual assumption that one usually makes when carrying out the said reductions?

(c) The deflection of the vertical has two components, a north-south component ξ , and an east-west component, η . Given that $\xi= 2.3''$ and $\eta = 3.1''$ compute the astronomical co-ordinates of a point with geodetic co-ordinates $\phi = -15^\circ 23' 41.9''$ $\lambda = 28^\circ 19' 57.2''$.

(d) Compute the free-air anomaly for the following stations

	ϕ	λ	H [m]	g [mGal]
i.	-13° 23'	28° 08'	1253	978345.59
ii.	-17° 39'	25° 50'	1021	978211.74

The GRS 80 gravity formula is:

$$\gamma = \gamma_a (1 + 0.0053024 \sin^2 \phi - 0.0000058 \sin^2 2\phi) \text{ mGal with } \gamma_a = 978032.7 \text{ mGal}.$$

PART B

Q4. (10 + 15)

(a) Briefly explain what is meant by

- i. Ambiguity resolution
- ii. Receiver clock error or offset
- iii. Ionospheric delay
- iv. Almanac data
- v. Differential GPS

(b) For the network below (page 3), station UZ104 was observed for twelve (12) hours using Leica's GPS System 200. Later, the baselines UZ104-ZT31; ZT31-LS492; ZT31-LS252 and LS252-LS492 was observed in rapid static for 15 minutes at 5 seconds observation rate. New points UZ175 and UZ170 were also observed as shown in the network.

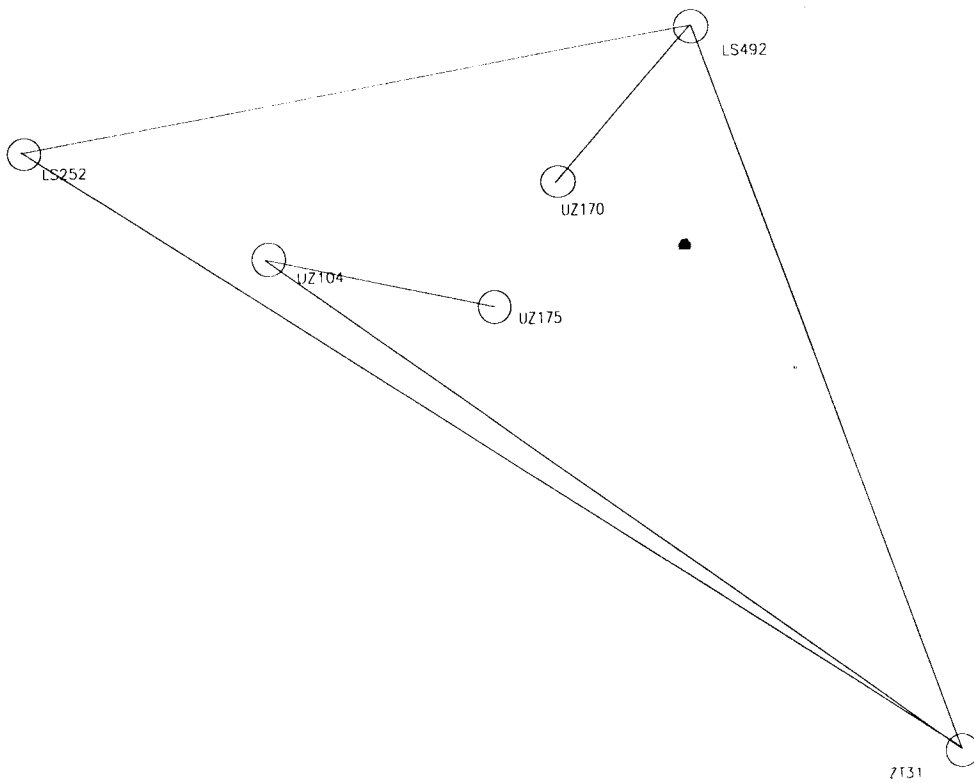

In steps, describe how you can obtain Clarke 1880 (Mod.) co-ordinates for points UZ175 and UZ170 using the above information. Assume that the data is already downloaded to your project in SKI and that you know the Clarke 1880 (Mod.) co-ordinates for the points ZT31, LS252, and LS492.

Q5 (3 + 15 + 7)

(a) Mention two methods of absolute gravity measurements.

(b) Show that

$$g = \frac{8s}{(t_4 - t_1)^2 - (t_3 - t_2)^2}, \text{ where } s \text{ is the distance and } t_i \text{ is time; } g \text{ is the gravity.}$$

(c) What do you understand by relative gravity measurement? Give an example of the principle of relative gravity measurement by gravimeters.

The University of Zambia
School of Engineering
Department of Surveying

University Examinations March 1998
SE561 Geographic Information Systems

Time: Three hours
Total marks: 100
Answer all 8 questions

Total number of pages: 3

1. Give a description of the following terms

- a. Polygonizing
- b. Edge matching
- c. Thiessen polygon
- d. Buffer zone

(4+4+4+4 marks)

2. Mention 5 advantages of GIS over the paper map

(12 marks)

3. The figures below are parts of a SPOT satellite image taken from two areas in Lusaka.

When we encode the images by run-length encoding, which figure (a. or b.) will give the biggest reduction in storage space when compared with its ordinary row by row encoding. Explain why.

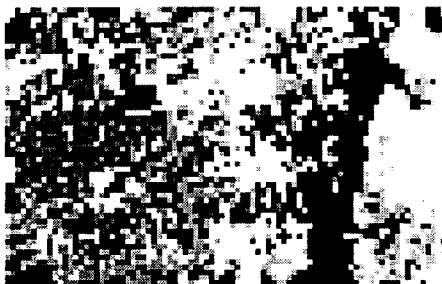

Figure a. Mutendere compound



Figure b. Farms south of Avondale

(10 marks)

4. a. Draw the path of the Morton scan order (base 2) for the following raster image (figure a).
An example is given in figure b. for the row prime order.

Question 4 continued

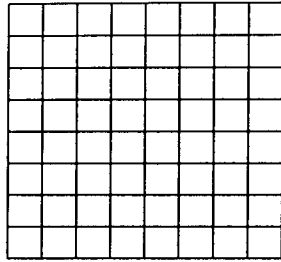
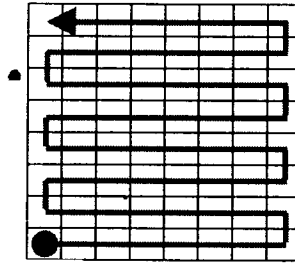

Figure a.

Example
(row prime order)



START

Figure b.

- b. Which hierarchical data structure is related to the Morton scan order ?
- c. What is, besides reduction of storage space, the advantage of the data structure mentioned in question b ?

(4+4+4 marks)

- 5. Mention 5 important measures of data quality.

(12 marks)

- 6. Given is the raster map below

	0	1	2	3
0	B	B	L	F
1	G	A	A	F
2	R	L	A	A
3	R	R	F	M

The table below gives for each grid cell the land use, the classification code in the map and the suitability for town expansion. Perform a normalization on this table.

(8 marks)

Grid cell	Land use	Code	Suitability
00	Built up area	B	N/A
01	Built up area	B	N/A
02	Lake	L	N/A
03	Forest	F	Low
10	Grass land	G	High
11	Agricultural	A	Moderate
12	Agricultural	A	Moderate
13	Forest	F	Low
20	Rock	R	Low
21	Lake	L	N/A
22	Agricultural	A	Moderate
23	Agricultural	A	Moderate
30	Rock	R	Low
31	Rock	R	Low
32	Forest	F	Low
33	Marshland	M	Low

7. a. One of the problems in initiating GIS in Zambia is the lack of input data, both analog and digital spatial data. Describe the importance of GPS and Remote Sensing in this matter.
- b. Mention some difficulties during the integration of several spatial data sources.

(7+7 marks)

8. State whether the following propositions are true or false. Explain why.
- a. Vector to raster conversion is technically more difficult than raster to vector conversion.
- b. Computer viruses cannot infect GIS software.
- c. ILWIS is a raster oriented software with additional vector capabilities.
- d. With registration we need at least 4 tie points to have redundancy.

(4+4+4+4 marks)

END OF EXAM

THE UNIVERSITY OF ZAMBIA
SCHOOL OF ENGINEERING
DEPARTMENT OF MECHANICAL ENGINEERING

UNIVERSITY EXAMINATIONS

AUGUST 1998

ME 252 ENGINEERING MATERIALS I

ANSWER: FIVE QUESTIONS
ALL QUESTIONS CARRY EQUAL MARKS

- Q1. Describe in detail the various types of atomic bonding that may be found in materials.
- Q2. (a) Discuss the effects of the following parameters on the possibility of any given materials to form a solid solution
- (i) Relative atomic size
 - (ii) Chemical affinity
 - (iii) Relative Valency
 - (iv) Crystal type
- (b) What are the differences between a eutectic system and a eutectoid system.
- Q3. Discuss the following:
- (a) The acid and basic processes of steel making
 - (b) Cast Irons
- Q4. (a) Discuss the effect of sulphur and phosphorus on steel.
- (b) State any two oxide ceramics and describe the differences between them and possible areas of application of each type.
- Q5. (a) Sketch and discuss in detail the Iron Carbon phase diagram.

- (b) Describe briefly
 - (i) Addition polymerization
 - (ii) Condensation polymerization
- Q6. (a) What are amorphous polymers?
Give examples of at least two of this group of polymers.
- (b) What is normalizing?
-

END OF EXAMINATION
Dr C K Wamukwamba

AUGUST 1998