

THE UNIVERSITY OF ZAMBIA LIBRARY

SCHOOL OF AGRICULTURAL SCIENCES

FIRST SEMESTER APRIL 2002

1. AGA 211 - Anatomy of Farm Animals
2. AGA 311 - Principles of Animal Nutrition
3. AGA 351 - Animal Science for Agricultural Engineering students
4. AGA 441 - introduction to Aquaculture Theory Paper
5. AGA 511 - Techniques in Animal Science
6. AGA 521 - Applied Animal Reproduction
7. AGA 531 - Topics in Animal Nutrition
8. AGC 521 - plant Breeding II
9. AGC 431 - Agricultural Entomology
10. AGE 311 - Rural sociology Examination
11. AGE 411 - Introduction to Agricultural Business management
12. AGE 421 -
13. AGE 431 - Linear Programming Applications for Agribusiness
14. AGE 511 - Agricultural Organization and Administration
15. AGE 521 - Farm Management
16. AGE 531 - International Agricultural Trade
17. AGE 541 - Agricultural Project Planning and Appraisal
18. AGF 211 - General Microbiology Theory paper
19. AGF 211 - General Microbiology Practical Paper
20. AGF 221 - Computer Sciences
21. AGF 311 - Methods in Food Analysis
22. AGF 321 - Food Chemistry Theory

- 23. AGF 321 - Food Chemistry Practical
- 24. AGF 341 - Thermodynamics
- 25. AGF 411 - Food Engineering
- 26. AGF 431 - Nutrition
- 27. AGF 441 - Water and Food Wastes Treatments
- 28. AGG 311 -
- 29. AGS 211 - Fundamentals of soil Science 1
- 30. AGS 311 - Agricultural Climatology
- 31. AGS 411 - Soil Fertility
- 32. AGS 431 - Soil Mineralogy and Micromorphology
- 33. AGS 441 - Agricultural Hydraulics and Hydrology
- 34. AGS 511 - Soil Chemistry
- 35. AGS 531 - Land Evaluation and Improvement
- 36. AGS 551 - Planning and Development of Irrigation and Drainage systems
- 37. EA 311 - Farm power and Machinery

THE UNIVERSITY OF ZAMBIA
UNIVERSITY FIRST SEMESTER EXAMINATIONS - APRIL 2002

AGA 211
ANATOMY OF FARM ANIMALS

TIME: THREE (3) HOURS

INSTRUCTIONS: **ANSWER ANY FIVE (5) QUESTIONS**
ALL QUESTIONS CARRY EQUAL MARKS.

1. You have completed a course in anatomy of farm animals. Your kid sister wants to know what the course is all about. These are some of the questions she has asked you:
 - a) What is anatomy? (2)
 - b) How do you study anatomy? (5)
 - c) Give an example of an organ in cattle and describe its anatomy using two of the methods you use in studying anatomy. (10)
 - d) Why is it necessary for you to know anatomy of domestic animals? (3)

2. Coordination of an animal's body is done by two systems, namely: the Nervous System and the Endocrine (Hormonal) System.
 - a) What do you understand by Peripheral Nervous system? (4)
 - b) Name the hormones produced by the Anterior Pituitary gland. (6)
 - c) What are Ganglia? (3)
 - d) Describe the Sympathetic Nervous System. (7)

3. The diaphragm separates the chest cavity from the abdominal cavity.
 - a) Describe the diaphragm? (3)
 - b) What organs are found in the chest cavity? (3)
 - c) Describe the stomach of a goat and compare it with the stomach of a chicken. (14)

4. Some anatomical descriptions have been put in formulas to make it easy to remember.
- a) Write the dental formula of a goat. (4)
 - b) What is the vertebral formula? (2)
 - c) Describe the forelimb of a goat. (6)
 - d) Why is the synovial joint called a true joint? Describe it and give an example. (8)
5. Activities of the reproductive system are responsible for perpetuation of species.
- a) Describe the female reproductive tract of a goat. (9)
 - b) What is the primary organ of a bull? (1) Describe (primary organ) it. (8)
 - c) What is the name of the common tube for expelling urine and spermatozoa? (2)
6. Write notes on any 4 of the following:
- a) Types of muscular tissues in the body. (5)
 - b) Areolar tissue. (5)
 - c) Classification of epithelia. (5)
 - d) Arterio-venous shunt. (5)
 - e) Differences between artery and vein. (5)

END OF EXAMINATION - GOOD LUCK

HAVE A PLEASANT HOLIDAY

THE UNIVERSITY OF ZAMBIA

UNIVERSITY FIRST SEMESTER FINAL EXAMINATIONS

APRIL 2002

COURSE: AGA 311
PRINCIPLES OF ANIMAL NUTRITION

TIME: 3 HOURS

INSTRUCTIONS: READ THE QUESTIONS CAREFULLY AND ANSWER AS INSTRUCTED. NOTE THAT THE QUESTIONS HAVE COMPONENTS AND CHOICE HAS BEEN INCORPORATED WITHIN MOST QUESTIONS.

SECTION ONE: ANSWER ALL QUESTIONS IN A SEPARATE BOOK

- 1 Write on five (5) of the following, using flow charts and giving examples where necessary:
- What is the fate of absorbed glucose in the animal body?
 - What conditions lead to Dark cutting meat in carcasses of cattle.
 - Lipids are a component of the diet in pigs. How are the lipids digested by this species of animals.
 - The process of fatty acid break down for energy generation in the animal body begins with the splitting of the fatty acid chains into 2-carbon units. Give the name of these 2-carbon molecules. What is the name of the process by which these 2-carbon units are produced? Outline the process of production of these 2-carbon molecules.
 - What are zymogens? Explain their role in animal body function.
 - Give the specific functions of five (5) named amino acids in the animal body.
- (15 points)
- 2 Discuss the following using flow diagrams where necessary:
- How the digestive system and processes of digestion in the young ruminant compare with those of the adult ruminant.
 - How rumen microorganisms affect protein digestion in ruminants.
 - How rumen fermentation products are absorbed and metabolized in the ruminant animal.
- (15 points)
-

SECTION TWO: ANSWER ALL QUESTIONS IN A SEPARATE BOOK

3 Give brief answers to two of the following:

- a) What are food toxicants? Name four types of toxicants and give an example of the toxic principles (compound) and how they are neutralized? (5)
- b) What are the main functions of the B vitamin complex and the minerals? (5)
- c) Define the mechanism of enzyme action and their functional models under physiological conditions. (5)

(10 points)

4 With the help of flow charts illustrate the following:

- a) Mechanism of vitamin D function in bone metabolism. (5)
- b) Give 3 main functions, 2 major deficiency symptoms and two sources of the B-Vitamin, Pantothenic acid and Cyano-cobalamine (B12). (5)
- c) Illustrate the absorption and hormonal control of Sodium (Na), Chlorine (Cl) and Potassium (K) in the small intestines. (5)

(15 points)

5 a) What is chemical score? The results from amino acid analysis of a protein are presented in the following table:

Essential amino acid profile	Egg protein	Test Protein
Methionine	0.75	0.56
Lysine	0.58	0.31
Phenylalanine	0.95	0.62
Cystein	0.66	0.43
Valine	0.88	0.67

- i) Calculate the chemical score of the test protein.
- ii) Contrast chemical score with biological value. Name one advantage and a disadvantage of the two methods? (6)

b) What is basal metabolic rate (BMR)? What factors affect BMR? (4)

(10 points)

6. In estimating energy expenditure, direct and indirect calorimetry can be used.

- a) Differentiate direct from indirect calorimetry. What are the basic principles on which they are founded? (5)
- b) The data collected from the Carbon and Nitrogen balance of a steer is given as follows:

Item	C(g)	N(g)	E kcal
Food intake	950	55	9425
Excreted in feces	388	18.5	3800
Excreted in urine	47	35.5	502
Excreted as CO ₂	385	-	-

Calculate:

- i) The carbon and Nitrogen balance
- ii) The metabolizable energy from the food he ate
- iii) Protein and carbon stored if any
- iv) Protein oxidized
- v) Net energy for production
- vi) Total heat produced
- vii) Net energy maintenance

(10 points)

Assume the following:

- Heat increment = 15%
 Carbon in fat = 74.6%
 Carbon in protein = 51.2%

(15 points)

7 Give brief answers to four (4) of the following:

- a) What factors influence the utilization of metabolized energy for production in terms of growth, Fattening or milk production? (5)
- b) In Europe, Australia and New Zealand they use starch equivalents (SE) developed by Kellner in evaluating food energy as opposed to the Total Digestible Nutrients (TDN) which is common in the United States of America (USA).
 - i) What was Kellner's basis for developing SE?
 - ii) A steer fed on sorghum diet gained 0.19g fat/g sorghum compared to 0.25g fat on a starch diet. What was the SE of this sorghum? How would you interpret the SE result? (5)

- c) How did Hetherington, Ranson, Brobeck and Anand prove that the hypothalamus has regulation centers for feed intake in the short term? What are the centers and what regulates them? (5)
- d). Is food intake regulation in ruminants different from non-ruminant animals? Name and explain five of them. (5)
- e). What conditions lead to ketosis in farm animals? Discuss carbohydrate metabolism in the diabetic animal. (5)

(20 points)

END OF EXAMINATION

THE UNIVERSITY OF ZAMBIA

END OF FIRST SEMESTER EXAMINATIONS (2001/2002)

APRIL 2002

**COURSE AGA 351 – ANIMAL SCIENCE FOR AGRICULTURAL
ENGINEERING STUDENTS.**

TIME ALLOWED: THREE (3) HOURS

INSTRUCTIONS TO CANDIDATES:

i) Answer question one (1) and any four (4) other questions.

- Q1. Discuss the following, giving examples where necessary:
- i) The role of rumen microorganisms.
 - ii) Farrowing pen.
 - iii) Stress hormones.
 - iv) Selection of work oxen. (40 Marks)
- Q2. Explain the management practices carried out in broiler production. (15 Marks)
- Q3. Write on the different components of a cattle handling unit and the purpose of each component in cattle husbandry. (15 Marks)
- Q4. i. Outline the annual cycle of a dairy cow.
ii Write on five (5) factors which affect milk composition. (15 Marks)

- Q5. i. Give the characteristics of any two (2) breeds of pigs.
ii. Explain the management practices carried out on piglets from birth to weaning.

(15 Marks)

- Q6. i. What are the advantages of sheep and goats over other livestock?
ii. Sheep and Goats are sometimes managed together in the same herd. Explain the reasons for the compatibility in management of these two species of livestock.

(15 Marks)

END OF EXAMINATION

UNIVERSITY OF ZAMBIA

SCHOOL OF AGRICULTURAL SCIENCES

DEPARTMENT OF ANIMAL SCIENCES

AGA 441 Introduction to Aquaculture

Theory Paper

First Semester Examinations

April 2002

Instructions

Attempt all the three questions in **Section A** and **two** questions in **Section B**. At the end of the examination, please hand in all the answer booklets and question papers.

SECTION A

1. A fish specimen caught had its standard length and total scale length measured. The standard length was found to be 550 mm and the total scale radius was estimated to be 10 mm. Four annual rings on the scale were recorded with the following lengths 4 mm 6 mm 8 mm and 9 mm. Using Lea's (1910) relationship.
 - i) Estimate fish lengths during its first four years.
 - ii) Describe different situation that may cause fish to deposit rings on scales or otoliths

2. Briefly explain common causes of the following problems in aquaculture facilities and how they could be addressed:
 - i) reduced transparency of fish pond water:
 - ii) fish gasping atmospheric air during the early hours of the day:
 - iii) high mortality of the fry in the holding ponds or tanks:
 - iv) Stunting of the fish in production ponds: and
 - v) Early breeding of farmed fish resulting in reduced growth rate.

3. The three - spot Bream, *Oreochromis andersonii*, is one of the fish species recommended for culturing particularly in the Kafue and Upper Zambezi catchment areas.
 - (i) Give reasons based on the biology of the Three - sport Bream as to why the culture if this species is recommended in areas indicated above:
 - (ii) What are the common problems encountered in the culture of this species: and
 - (iii) How are the problems described in (ii) above commonly addressed.

SECTION B

4. List and briefly describe factors that influence growth of fish. Explain how the aquaculture systems are designed and managed in order to promote fast growth rate of fish in aquaculture facilities.

5. Most species of fish used in aquaculture exhibit high fecundity both in the wild and in fish farming situations.
 - (i) Briefly explain behavioral strategies among Cichlids both in the wild and in fish ponds designed to reduce larva mortalities.
 - (ii) How are fish farms designed and managed so as to reduce high fry mortality.

6. List and describe common environmental problems that arise from aquacultural activities and describe mitigation measures designed to minimize and avoid negative impact of aquaculture operations on the environment.

END OF THE EXAMINATION

THE UNIVERSITY OF ZAMBIA
UNIVERSITY FIRST SEMESTER EXAMINATIONS APRIL 2002
TECHNIQUES IN ANIMAL SCIENCE

(AGASII)

TIME: 3 HOURS

INSTRUCTIONS: ANSWER EACH SECTION IN A SEPARATE ANSWER BOOK. ANSWER ALL QUESTIONS.

SECTION 1: Production Management And Research Techniques

1. The prospect for formal employment in Zambia after graduation are very low and the degree you are attaining incorporates applied sciences and field work, thus you should be able to go into self employment. In addition, there are a number of financing agents that support smallholder entrepreneurs with low cost loans. Your knowledge of practical farming from your field attachments, field station, field visits and lecture material make you a qualified candidate to apply for such a loan and go into business. You have a choice of going into pig, poultry or beef or dairy enterprises. Put up a proposal that justifies your choice of enterprise under the following guide:

- a) What are the basic components of a project proposal?
- b) What are the major animal and facility considerations you need to address in order to have a profitable livestock enterprise?
- c) What are the major constraints to start a livestock enterprise in Zambia in terms of production and its support systems and how would you overcome them?

(20 points)

2. Livestock production management requires a systematic reconciliation of production record, visual observation of the stock and profitability of the enterprise. Briefly discuss the following:

- a) What is the importance of condition scoring in livestock production systems? What factors would you look for to evaluate the expected performance of the following livestock;
 - Dairy cows
 - Breeding bull and
 - Sheep for wool production?
- b) Why is culling important in a laying flock and dairy cattle? How would you go about culling in a laying flock and a dairy herd?
- c) Define three techniques used in animal research and briefly explain the principle on which they are based.

(20 Points)

SECTION 2: Experimental Design and Data Analysis

3. (a) As an animal scientist one of the responsibilities that you must discharge is communication of your scientific investigations to other users. Outline as you understand what you MUST consider in making an oral presentation. (8 points).

(b) Factorial experiments are commonly used in animal science investigations and below are results from a study of the effect of source of protein and level of protein on weight of rabbits.

Level of protein	Source of protein	
	Animal	Vegetable
High	99.8	85.9
Low	79.0	83.9

The Analysis of Variance table is as follows:

Source of Variation	Degree of freedom	Sums of squares	Mean Squares	F-value (calc)	F-value (table)
Factor A (Source)	2	266.5	A	B	M
Factor B (Level)	1	3168.3	B	F	I
A x B	2	1178.2	C	G	J
Error	54	11585.0	D		

- Fill the values in the boxes with letters A to J
- Give an interpretation of the results
- Calculate the simple effects and interpret the outputs in full

(12 points)

SECTION 3: Blood Collection and Analysis

4. Blood analysis using serum or plasma is the most common analysis used in determining the physiological and health status of domestic animals.

- Describe one method of collecting blood from a cow.
- What is the difference between plasma and serum and how do you collect these two?
- Describe a methodology used in determining differential white blood cell count. Why is this an important test?

20 points

SECTION 4: Animal Draft Power

- 5 a) Nutrients for any class of livestock are generally divided into four classes; vitamins, minerals, proteins and energy giving nutrients. Discuss the effect of work on the requirements for these classes of nutrients.

10 points

- b) There is growing interest in the multi-purpose animal producing calf, work, milk and dung. Outline the advantages of such an animal over the traditional single-purpose animal such as the ox.

10 points

THE UNIVERSITY OF ZAMBIA
UNIVERSITY FIRST SEMESTER EXAMINATIONS – APRIL 2002
AGA 521 – APPLIED ANIMAL REPRODUCTION

TIME: **3 HOURS**

INSTRUCTIONS: **ANSWER ANY FIVE (5) QUESTIONS. ALL
QUESTIONS CARRY EQUAL MARKS.**

1. Describe the process of fertilization to the zygote formation stage, outlining the sources of nutrition for the zygote from its formation to the fetal stage following implantation.

2. Give a basic physiologic explanation for each of the following. Be complete by following the events to completion; such as, lack of ovulation was due to a lack of LH secretion by the anterior pituitary gland. It is important to demonstrate your depth of knowledge of endocrine, neural and/or anatomical function in each case.
 - a. A sow showed heat 3 days after farrowing, but did not conceive when mated.
 - b. A cow suckling 2 calves has not shown heat since calving 90 days ago. Nutrition has been optimum for the past year.
 - c. A ewe did not show heat with the first ovulation at the start of the breeding season.
 - d. PMSG was found in the blood of a pregnant mare, but not in the urine.

3. For each of the phenomena listed, give the following information:
 - (i) physiological status of the animal (e.g. estrual, metestrus I or II, pregnant etc.)
 - (ii) factors involved (e.g. hormones, anatomical structures etc.).

- a. A blood sample from a cow was analysed for hormone effect levels and the following was found:

Below Dominance

L.H.
Progesterone

Dominant

Estrogen
FSH
Pgl₂

(Be sure to follow the instructions for this question)

- b. A blood sample from a cow showed LH to be the only really dominant hormone.
- c. The ovaries were removed from a cow and by general examination (no microscope) it was determined that the cow was cycling regularly and she probably would have been in heat 12 to 18 hours.
- (i) What structures did the observer see (name all and condition)?
- (ii) What specific observations made the description of the cow's physiological status possible?
4. a. A mare differs from other farm animals in ovarian function during pregnancy. State the differences that have been observed. Tell what hormone complex may contribute to some of the differences and why the hormone reaches significantly high levels.
- b. Most cows do not return to estrus until 45+ days post-partum. This seems to be a "built-in" factor for successful gestation. What are the uterine changes taking place during this post-partum period?
- c. What factors other than uterine may delay first post-partum estrus longer than 45 – 60 days?
5. a. Define and contrast infertility and sterility.
- b. What is the effect of heat stress on reproduction in cattle?
- c. What is the mechanism of action of heat stress in cattle?
- d. What measures would you take to reduce effects of heat stress?

6.
 - a. Describe Artificial Insemination procedures in cattle with regard to semen collection, time of insemination and insemination procedure.
 - b. What physiological factors reduce reproductive efficiency in a cow?

THE UNIVERSITY OF ZAMBIA

END OF FIRST SEMESTER EXAMINATIONS – APRIL, 2002

COURSE AGA 531 - TOPICS IN ANIMAL NUTRITION

TIME ALLOWED: - THREE HOURS ONLY.

INSTRUCTIONS TO CANDIDATES: -

a) *Answer Question 1, and any three (3) others.*

Q. 1 Formulate a broiler ration for the third phase feeding in the three-phase feeding programme for a commercial farmer who wishes to use of the locally available feed ingredients. The broiler ration should contain 3,200 Kcal/kg ME, 20% DCP, 1% lysine, 0.6% Methionine, 1.0% Calcium. 0.75% Phosphorus, 1% Broiler (Vitamin and Mineral) Premix and 1.0% Salt.

The following feed ingredients are available: -

INGREDIENT	ME(Kcal/kg)	COMPOSITION				
		CP%	LYSINE%	METHIONINE%	Ca%	P%
Maize Meal	3350	8.8	0.24	0.20	0.02	0.28
Soyabean Cake	2230	44.0	2.93	0.63	0.29	0.65
Tallow	8000	-	-	-	-	-
Dicalcium Phosphate	-	-	-	-	26.0	18.0
Limestone Flour	-	-	-	-	38.0	-

(40 Marks)

Q. 2 a) Chemical and biological methods of protein evaluation of pig and poultry feeds are used by researchers but some rely on biological methods that are based on the response of experimental animals. Calculate the True Biological Value of animal feed supplement from the data given below: -

- i) Daily dry matter consumption = 6.00 grams;
- ii) Nitrogen percentage in the feed, on dry matter basis = 1.043;
- iii) Daily urinary output = 10ml containing 3.28 mg total nitrogen per ml and 2.2 mg endogenous nitrogen; and
- iv) Daily faecal output = 5 gram dry matter containing 4.28 mg/g total N and 2.14 mg/g metabolic faecal nitrogen.

- b) Write brief notes on the methods of increasing the digestibility of forages that can be put into practice on a farm of your choice.

(20 Marks)

- Q.3 a) If a 550 kg Holstein dairy cow in mid-lactation (no weight change) eats 25 kg *Chloris guyana* (Rhodes Grass) and produces 20kg milk containing 38g butterfat and 88 g solids-not-fat per kg, how much concentrate mixture (2:1:1:1) consisting of Maize Meal : Fish Meal : Fuzzy Cotton : Molasses will she need to eat to provide sufficient energy to maintain her body weight?

The following may be used to answer the question: -

	DM (g/kg)	ME (MJ/kg DM)
Rhodes Grass	300	8.5
Maize Meal	96	12.0
Fish Meal	96	13.0
Fuzzy Cotton	92	10.0
Molasses	77	14.5

- b) If the 550kg Holstein dairy cow in a) above was in early lactation and was actually losing 0.5kg per day, how much concentrate mixture will she need to eat to maintain her body weight?
- c) If the 550kg Holstein dairy cow in a) above was in late lactation and was actually gaining 0.5kg per day, how much concentrate mixture will she need to eat to maintain her body weight?
- d) How much is a Boran steer weighing 285kg expected to grow if it is fed on daily ration consisting of the following feed-stuffs: -

9.5 kg Maize Silage (300 g/kg DM, 8.6 MJ ME/kg DM)
7.5 kg Maize Meal (850 g/kg DM, 12.5 MJ ME/kg DM)
2.5 kg Cane Molasses (270 g/kg DM, 13.0 MJ ME/kg DM)

(20 Marks)

- Q. 4 The digestibility of forages affects the dry matter intake (DMI) of such forages in ruminants but it is the DMI that determines animal productivity.

- a) Describe the methods that can be used in the laboratory to estimate the digestibility of forages.
- b) What are the advantages and disadvantages of the fore-stomach fermentation as opposed to hind gut fermentation.

(20 Marks)

Q. 5 Write notes on the following: -

- a) The causes of Acidosis and discuss how the condition can be prevented in a herd of cattle.
- b) Cyanogenetic glycosides and glucosinolates;
- c) The Peter van Soest method of determining the nutritive value of forages; and
- d) Bloat and discuss the methods of bloat treatment that can be used as an emergency in order to avoid deaths in affected cattle.

(20 Marks)

The following may be used to answer any questions:

- i. $Mm = 8.3 + 0.091 W$
- ii. $DMI = 0.025 W + 0.1 Y$
- iii. $Eg = \frac{MEP \times 0.0435 M/D}{1.05}$
- iv. $EVI = 0.0386 BF + 0.0205 SNF - 0.236$
- v. $LWG = \frac{Eg}{6.28 + 0.3 Eg + 0.0188 W}$
- vi. $FD = \frac{DMI (MC - M/D)}{(MC - MF)}$
- vii. $Ml = \frac{EVI \times 1.05}{0.62}$
- viii. $Kl = \frac{0.0435 M/D}{1.05}$ or $0.0414 M/D$

END OF EXAMINATION

UNIVERSITY OF ZAMBIA
SCHOOL OF AGRICULTURAL SCIENCES

FIRST SEMESTER EXAMS - APRIL 2002

AGC 431 : AGRICULTURAL ENTOMOLOGY

TIME: 2 1/2 HOURS. ANSWER ALL QUESTIONS. ALL QUESTIONS CARRY EQUAL MARKS.

1. Discuss the complications associated with insect identification and outline ways in which one may identify an insect.
2. Compare and contrast the distinguishing characters of the order Mallophaga and Anoplura.
3. Outline the functions of an exoskeleton and discuss the consequences of possessing such a structure in insects.
4. What is legislative control? Discuss in detail the functions of a plant quarantine division.
5. The sole reliance on insecticide for the control of insect pests has led to many problems. Discuss.

THE UNIVERSITY OF ZAMBIA

SCHOOL OF AGRICULTURAL SCIENCES

CROP SCIENCE DEPARTMENT

UNIVERSITY EXAMINATIONS – APRIL 2002

AGC 521 PLANT BREEDING II

Answer Five Questions.

All Questions carry equal marks

Marks

20

1. Write short notes on the following:

- a). Chromosome manipulation for crop improvement.
- b). The *Agrobacterium tumefaciens* mediated plant transformation
- c). Breeding for biotic stresses in plants.
- d). Somaclonal variation in germplasm conservation and crop improvement.
- e). Laminar flow chamber

20

2. Discuss the mechanisms of disease resistance in plants and how breeders exploit them in breeding for disease resistance in crop plants.

ANSWER EITHER QUESTION 3 OR 4

20

3. It has been observed that cases of iron (Fe) deficiency among the rural poor whose diet is predominantly maize based are increasing in Zambia. This situation has become so serious that it is becoming fatal among women and children.

Nutritionists have linked this problem among the poor to their inability to regularly eat red meat which is high in iron because of their poor buying power. As a result of this, their diets are predominantly plant (and in particular, maize) based and hence not taking in enough iron in their bodies. Maize is generally low in iron content in the grain. To make matters worse maize breeders never thought of iron content an important selection objective in the past. All breeding efforts have been for yield improvement.

The Government of the Republic of Zambia has resolved that breeders have to develop maize varieties which have a high iron content in the grain to overcome the problem of wide spread anaemia among the poor which is a result of dietary iron deficiency. Information from literature indicates that this is becoming a new area of concern among the poor Worldwide. The little research information on this subject indicates that the

activity of the enzyme **Phytase** in maize is responsible for the efficiency of iron uptake and concentration in maize grain.

If you were given the task as a fresh new UNZA graduate to initiate this breeding program for developing maize varieties with increased grain iron content, **state clearly and comprehensively how you would tackle this task in view of the fact that the National Gene Bank has thousands of maize accessions.**

20

4. A population of maize was investigated for biological yield inheritance for silage making using the North Carolina Design II. The experiment consisted of all possible crosses among 5 plants designated as male plants and 5 plants designated as female plants. Five (5) progeny plants were grown from each cross as single randomised plants in four (4) blocks. The ANOVA table is given below. Yields were in MT/HA.

Source	Df	SS	MS	F test	EMS
Males (M)	4	2323	580.75	**	$\sigma^2_w + nb\sigma^2_{MF} + nbf\sigma^2_M$
Females (F)	4	2379	594.75	**	$\sigma^2_w + nb\sigma^2_{MF} + nbm\sigma^2_F$
F X M	16	5463	341.44	**	$\sigma^2_w + nb\sigma^2_{MF}$
Blocks (B)	3	120	40.00	ns	
B X F	12	299	24.92	ns	
B X M	12	779	64.92	ns	
B X F X M	48	2903	60.48	ns	
Within families	401	27195	67.82		σ^2_w
Pooled within families	-----	-----			σ^2_w

a). Complete the ANOVA

b). Discuss in detail the broad sense and narrow sense heritability estimates as regards the way forward for developing maize varieties for silage making.

20

5. Discuss mechanisms of disease resistance in plants and how you can exploit these mechanisms in breeding for disease resistance in crops.

6. a). List breeding methods applicable for sunflower and rice

b). Discuss the statement “ The ultimate success of Plant Breeding depends on the success of the County’s Seed Industry”

-----END OF EXAMINATION-----

UNIVERSITY OF ZAMBIA
UNIVERSITY EXAMINATIONS – FIRST SEMESTER EXAMINATION

MAY, 2002-04-10

AGE 211: FUNDAMENTALS OF MICRO-ECONOMICS

INSTRUCTIONS: ANSWER ALL QUESTIONS IN SECTION A AND ANY FOUR FROM SECTION B

TIME: 3 HOURS

SECTION A: Multiple choice questions: Answer all Questions on the Question paper and hand it in together with the answer booklet.

1. Demand curves are usually drawn with quantity on one axis and price on the other, because price is without doubt the most important determinant of demand. T/F
2. A discovery that reduces the cost of producing a commodity will usually, ceteris paribus, increase its supply. T/F
3. A fall in quantity supplied causes an increase in equilibrium price T/F.
4. If the elasticity of demand for a commodity exceeds unity, a fall in its price will result in an increase in the total amount of money spent by consumers on purchases of that commodity? T/F.
5. The industry supply curve is the vertical summation of the individual firm's supply curves? T/F.
6. The market experiences a when the price is above equilibrium and a when the price is below equilibrium.
 - a) Shortage shortage
 - b) Surplus surplus
 - c) Shortage surplus
 - d) Surplus shortage
 - e) None of the above.
7. In figure below if the price of K3 is fixed by government decree, there will be
 - a) a shortage of 2000;
 - b) a surplus of 2000;
 - c) a shortage of 1000;
 - d) a surplus of 1000; or
 - e) an unpredictable result

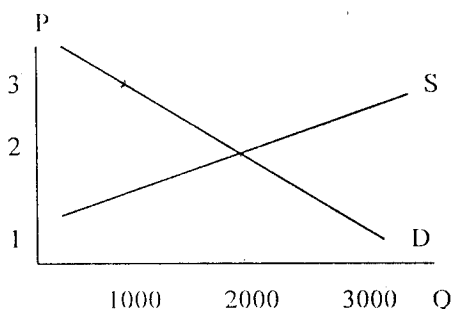

8. Price elasticity of demand for a commodity tends to be greater -
- Where it is more of a necessity;
 - When more substitutes are available for it;
 - Over shorter time periods;
 - When the price is lower or
 - b, c, and d.
9. If the supply of a commodity is totally inelastic
- Its price cannot change;
 - The demand curve cannot intersect the supply curve.
 - The supply curve will be horizontal,
 - The demand curve will be perfectly inelastic or
 - The demand for the commodity will determine its selling price.
10. The marginal cost curve
- is increasing when law of diminishing returns is operative;
 - intersects the average variable cost curve at its minimum.
 - Intersects the average total cost curve at its minimum;
 - Exceeds the average total cost (ATC) curve when ATC is rising or
 - All of the above.
11. The law of diminishing returns states that if increasing quantities of a variable factor are applied to a given quantity of fixed factors -
- the marginal product of the variable factor will eventually decrease;
 - the marginal product will eventually decrease, while average product remains constant;
 - the marginal product becomes negative,
 - the total product cannot be increased or,
 - none of the above answers is correct.
12. An indifference curve includes:
- constant quantities of one good with varying quantities of another,
 - the prices and quantities of two goods that can be purchased for a given sum of money.
 - all combinations of two goods that will give the same level of satisfaction to the household.
 - combinations of goods whose marginal utilities are equal
13. Re-arrange the following symbols such that they state the condition for cost minimization (in an industry whose two factors are labour and capital),
- $$P_l = MP_k, \quad MP_l, \quad P_k$$
14. An isocost line for two factors C and L (their respective prices are P_c and P_l) could have which of the following equations?
- $LC = K100$
 - $K100 = P_c + P_l$
 - $K100 = P_l L + P_c C$
 - $K1,000 = P_l C$
15. If more firms enter a competitive industry, our theory predicts that
- marginal cost curves rise;
 - the industry supply curve shifts to the right;

- c) output of all existing firms increases;
 - d) product prices fall;
 - e) all of the above answers are correct;
 - f) both (b) and (d) are satisfactory.
 - g) None of the above answers is satisfactory.
16. The theory of price discrimination predicts that in comparison to single price monopoly
- a) output will increase, and average revenue will decrease.
 - b) Output will increase, and average revenue will increase.
 - c) Output will decrease, and average revenue will decrease.
 - d) Output will decrease, and average revenue will increase.
 - e) None of the above answers is satisfactory.
17. The important difference between our assumptions for monopolistic competition and those for perfect competition is that monopolistic competitors
- a) don't try to maximise profits,
 - b) worry about their influence on the market,
 - c) have an inelastic demand curve facing them,
 - d) sell similar but not identical products.
18. Among the essential aspects of oligopoly is
- a) excess capacity,
 - b) non-price competition,
 - c) a large number of firms,
 - d) mutual recognition of interdependence,
 - e) both (a) and (b) are satisfactory,
 - f) both (b) and (c) are satisfactory,
 - g) none of the above.
19. A monopolist has control of the price he charges for his product. He will thus be able to maximize his profits by:
- a) raising his price by the whole amount of a tax thus passing it all on to his customers,
 - b) absorbing the whole of any cost reductions into his profits, thus passing on to his customers none of the benefit.
 - c) Neither (a) nor (b)
20. Equilibrium of the monopolistic firm
- a) occurs where $P = MC$,
 - b) occurs where $MR = MC$,
 - c) occurs where $P = MR$,
 - d) necessarily is profitable,
 - e) both (c) and (d) are satisfactory,
 - f) both (a) and (d) are satisfactory,
 - g) none of the above.

(20 marks)

SECTION B: Answer any four (4) questions from this section.

1. Why is it desirable for ceiling prices to be accompanied by government rationing? Show graphically why price ceilings entail shortages. What effect, if any, does the elasticity of demand and supply have upon the size of these shortages and surplus? Explain.
2. Mr. Mate buys loaves of bread and litres of milk each week at prices of K1.20 and K1.00 respectively. At present, he is buying these two products in amounts such that the marginal

utilities from the last units purchased of the two products are 120 and 110 units respectively. Is Mate currently buying the best, that is, the utility – maximizing, combination of bread and milk? If not, in what manner should he reallocate his expenditures between the two goods?

3. Explain what you understand by the following concepts:
 - a) Least cost combination
 - b) Marginal rate of technical substitution,
 - c) The law of diminishing returns,
 - d) Second degree price discrimination
4. Using a diagram, show the short-run
 - a) Profit maximising output and price of a firm under perfect competition. If $P > MC$ what should the firm do to increase profits? If $MC > P$ what should the firm do to increase profits? Show all your work on the diagram.
 - b) Show how a firm would be operating at a loss in the short run.
5.
 - a) What are the major sources of monopoly power? Is it correct to say that in some cases the government is responsible for the creation of monopoly power?
 - c) Explain why a monopolist is said to reduce the welfare of consumers.
6. Fewness of rivals means mutual interdependence, and mutual interdependence means uncertainty as to how these few rivals will react to a price change by any one firm. Explain in what kind of market structure do you find such a relationship. Of what significance is this for determining demand and marginal revenue curves?

.....END OF EXAM

THE UNIVERSITY OF ZAMBIA
DEPARTMENT OF AGRICULTURAL, RURAL, FISHERIES &
EXTENSION EDUCATION
AGE 311 – RURAL SOCIOLOGY EXAMINATION

INSTRUCTIONS

ANSWER FIVE QUESTIONS ONLY
ALL QUESTIONS CARRY EQUAL MARKS (20 MARKS)
TOTAL MARKS: 100

QUESTIONS

1. What is gender and what agricultural development related problems does it try to solve?
2. Compare and contrast major characteristics of the concept formal and informal organisations. Indicate where possible those characteristics that might serve as a barrier to the adoption of new ideas.
3. What are the functions of the family and why as a social institution is a family considered an arena of conflict between 'individuals' and 'society'.
4. Define the term social stratification and explain the effect of stratification upon the sharing of knowledge and flow of ideas through a society.
5. Discuss four major characteristics of a social system and emphasise how each fits into the whole system.
6. Write short notes on the following:
 - a) Dependency theory
 - b) Culture
 - c) Land tenure system
 - d) Socialization

THE UNIVERSITY OF ZAMBIA

SCHOOL OF AGRICULTURAL SCIENCES

DEPARTMENT OF AGRICULTURAL ECONOMICS

FIRST SEMESTER EXAMINATION

**AGE 411 – (INTRODUCTION TO AGRICULTURAL BUSINESS
MANAGEMENT)**

DATE: 3rd April 2002

TIME: Three hours

INSTRUCTIONS:

- Answer any four questions out of six questions
- All questions carry equal marks

Question 1

The Zambia Agricultural System (i.e. planning, extension and marketing) needs to undergo a major overhaul in order for it to contribute to the economic and social development of the nation. To achieve this you need to have people with entrepreneurial thinking because entrepreneurs world over, have been known to be change-agents.

- a) What is entrepreneurship, and what are the characteristics of entrepreneurs?
- b) Entrepreneurs believe in the business maxim, which says, "THE HIGHER THE RISK, THE HIGHER THE EXPECTED RETURN."
 - i. What does this maxim signify?
 - ii. How would this maxim help a small scale farmer develop a better business orientation?
- c) Entrepreneurship is known as the engine for economic and social development. Explain how this principle works.

Question 2

The first source of finance available to the business is THE OWNER'S CAPITAL and then followed by BORROWED CAPITAL. The major source of borrowed capital are Banks. Banks have lending rules and every business professional is expected to understand and appreciate these rules.

- a) List down the three lending rules and explain the details under each of these rules.
- b) Why is OWNER'S CAPITAL important when it comes to borrowing capital for businesses?
- c) Write down the balance sheet equation and explain the significance of each of the elements in the equation

Question 3

The following table shows the capital structure of Kama Farms, for the year 2001.

1.0	Debt at 10% interest	\$ 900
2.0	Equity	\$ 100
	Total Assets	<u>\$ 1000</u>
	EBIT	\$ 120
	Less Interest Expense	<u>90</u>
	Earnings before Tax	\$ 30
	Less tax at 40%	<u>\$ 12</u>
		\$ 18

- a) Calculate ROE, ROA and ROIC for Kama Farms Ltd.
- b) Explain the role of ROE, ROA and ROIC in financial analysis. In other words, what do they signify?
- c) Acid-Test and Quick-Test ratios are vital liquidity ratios -
 - i. Define the term liquidity and explain its significance.
 - ii. Show the mathematical formula for both ratios.
 - iii. Which of the two ratios would you advise a business person to use and why?

Question 4

For any new business venture (i.e. poultry, beef, pork, etc), to succeed, there is need to create awareness of the product amongst would be customers. The promotion mix is one of the tools used in creating business awareness.

- a) What are the components of the promotion mix?
- b) How can you use the promotion mix to create product awareness amongst potential customers?
- c) Is the promotion mix necessary in a business environment where the marketing concept is fully utilized? Give reasons to support your answer.
- d) What is marketing mix and what are its components.

Question 5

- a) During the formation of a business, the following three statements are vital and are commonly referred to as strategic statements, and these are: mission, value and vision statements.
 - i. What is a mission statement?
 - ii. Why is a mission statement important in an organization?
 - iii. What is a value statement and what are its components?
- b) Briefly explain how a business strategy is formulated. In other words, what are the determinants of a business strategy?

Question 6

- a) What is an organizational chart?
- b) What is the role of an organization chart in human resource planning?
- c) Is there any distinct difference between leadership and management? Give reasons to support your answer.
- d) Why is human resource management important in an organization?

THE UNIVERSITY OF ZAMBIA
UNIVERSITY EXAMINATIONS-APRIL 2002

AGE 421

TIME: THREE HOURS

INSTRUCTIONS:

ANSWER NUMBER ONE (1) AND ANY OTHER FOUR (4) QUESTIONS

1. In Zambia, maize is a very important crop. Research has established that up to a certain point, there is a positive relationship between yield and nitrogen fertilizer.

Given the following production function:

$$Y = 70 + 2X - 0.02X^2$$

- a) Determine and interpret the marginal and average physical product
- b) Estimate and interpret the elasticity of production
- c) Find the output maximizing level of input use
- d) Some people argue that there is no need to expand the total planted area of maize. In order to feed the rising population, farmers should just be encouraged to apply increasing quantities of fertilizer on existing cultivated areas.
Using illustrations, discuss this position.

2. Consider the production function:

$$Y = 68 + 0.8X - 0.002X^2$$

Where Y = grain sorghum in 90kg bags
X = nitrogen in Kg per hectare

- a) Find the optimum Kgs of nitrogen per hectare to apply under different crop and nitrogen prices and note the amount in appropriate blank columns in the following table

Nitrogen Price Per Kg of N (K)	Sorghum Price per 90 kg bag (K)				
	1500	2000	2500	3000	3500
00	-	-	-	-	-
200	-	-	-	-	-
400	-	-	-	-	-
600	-	-	-	-	-
800	-	-	-	-	-

b) At what P_x/P_y ratio would the net returns of sorghum be zero?

3. a) Define and briefly discuss the concept of economic efficiency.

b) Assume that a farm is operating in a purely competitive market and that its input-output relationship is of the following form:

$$Y = X_1^{1/3} X_2^{1/3}$$

Where

$$P_{X_1} = \$10$$

$$P_{X_2} = \$10$$

There is no fixed cost. At how many units of output, Y , will the farm maximize the net returns when the price of the product $P_y = \$270$?

c) Consider the production function

$$Y = X_1 X_2$$

Where $P_{X_1} = \$20$, $P_{X_2} = \$10$

Which combination of X_1 and X_2 will produce maximum output when the manager has only \$10,000 to spend on X_1 and X_2 ?

4. Consider the production function

$$Y = 70 + 2X - 0.005X^2$$

- a) Find the level of X at which Y is a maximum
 - b) Calculate the elasticities of production when $X = 40$. Interpret the result
 - c) Find the levels of X maximizing the net returns when $P_x = \$10$ and $P_y = \$100$
 - d) Define the expansion path. How would you derive the expansion path? (Hint: Use mathematics)
5. a) Explain the consequences to the farmer if the production function for milk were a linear function of the amount of feed fed to each cow.

b) Suppose the production function is

$$Y = 2X^{0.5}X^{0.333}$$

Find

- i) The MPP of X_1
 - ii) The MPP of X_2
 - iii) The marginal rate of substitution of X_1 and X_2
- c) Briefly define and discuss the following terms:
- i) Isocost lines
 - ii) Substitution Effect
 - iii) Discounting
 - iv) Net Present Value
6. Some farm management specialists often state that the farmer desires to maximize returns per dollar spent.
- (a) Is this goal consistent with profit maximization when capital is unlimited?
 - (b) Is it consistent with the general equimarginal principle when capital is limited?
 - (c) In what special case would the use of the optimum also maximize returns per dollar spent?

END OF EXAM

The University of Zambia
University First Semester Examinations – April 2002

AGE 431
Linear Programming Applications for Agribusiness

Instructions: Answer Question 1 in Section A (40 points) and any ~~three~~^{two} of the four questions in Section B (30 points each)

Time: Three (3) hours

Section A. Research Methodology (40 points)

Answer the following question in full. It is worth 40 points.

1. Conventional farming practices that involve full cultivation and removal and burning of residues have come under increasing criticism in recent years due to the adverse effects they have on the soil and sustainability. The Ministry of Agriculture and Cooperatives (MACo) would like to examine the possibility of promoting alternative agricultural practices, such as conservation farming. However, MACo needs to know the economic viability of such alternative practices and have asked you to prepare a proposal for a study along these lines. Answer the following questions.
 - a) Compare and contrast a research proposal and a research report.
 - b) Why do you think MACo would be interested in a proposal as opposed to commissioning the study without the proposal?
 - c) Why is your objectivity important as you prepare the research proposal?
 - d) When writing the proposal what components (sub-headings) would you want included? Be sure to explain what these components are, their role and how they relate to each other in the research process.
 - e) Compare and contrast validity and reliability. Which of the research components referred to in ~~d~~ above can help you avoid logical fallacies? Explain.
 - f) Why is it important to maintain a one-to-one matching of ideas and focus across the different components of the research proposal?
 - g) Scientific research relies on science and science relies on research. Define science and research and explain why neither can function without the other.

- h) Distinguish between applied and basic research. Which of these research classifications best suits the research problem at hand? Explain.
- i) Define facts, theory and hypotheses and explain how they are related.
- j) Define deductive and inductive logic. Explain why we need both deductive and inductive reasoning in the research process.

Section B. Linear Programming (90 points)

~~two~~

Answer ~~three~~ of the following four questions. Each is worth 30 points.

2. Mr. Zikondwela, a medium-scale farmer in Eastern Province, is considering growing paprika and/or cotton. Paprika returns K400,000 per acre while cotton returns K200,000 per acre. The farmer has 240 hours of family labour and 40 acres of land. He has also just bought and delivered to his homestead 8,400 kg of fertilizer from a nearby depot. Cotton requires 8 hours of labour and 150 kg of fertilizer per acre. An acre of paprika requires 10 hours of labour and 400 kg of fertilizer.
- Set up algebraically the profit-maximizing linear programming problem.
 - Translate the algebraic model in a) above into a tableau format.
 - Use the simplex method to solve the problem.
 - Determine the optimal value of the objective function and the optimal levels of all real and slack activities.
 - Explain each value in the opportunity cost row.
 - Set up the dual problem algebraically and in a tableau format.
3. Mr. Shibulimi is an emerging farmer in Kafue. His farm has 24 acres of arable land and he is considering growing maize, cotton and/or sunflower in the 2001/2002 agricultural season. Maize, cotton and sunflower have gross margins of K600,000, K500,000 and K300,000, respectively. The farmer is most limited on working capital (only K4,150,000 available) and human capital in the month of February (120 man days). Given the production technology available to the farmer, he would need to spend K250,000 of working capital to produce an acre of maize and K50,000 of working capital to produce an acre of sunflower. An acre of cotton requires K100,000 of working capital and 15 man days of February labour.

Mr. Shibulimi has just asked you to be his consultant, for a good professional fee, of course. He wants you to tell him how he can allocate his resources among the three crops in order to maximize his profits. He also wants to know the maximum possible profit level and true opportunity cost of each of his scarce resources. Use your knowledge of linear programming to answer his questions.

4. A farmer has 160 hectares of land and proposes to grow maize and tobacco. He has 65 man-days of December labour and 110 man-days of January labour available. He requires 0.5 man-days of December labour per hectare and no January labour for maize and needs 1 man-day of January labour for each hectare of tobacco. The net returns from each hectare of maize and tobacco are K320,000 and K160,000, respectively. The farmer seeks to maximize his total profits.
- Specify, algebraically and in a tableau, the primal LP model.
 - Solve the problem graphically OR by the simplex method.
 - Determine the optimal values of the objective function and real and slack activities.
 - Specify the dual to the problem in a).
 - What is the economic interpretation of dual variables?
5. Use the attached Microsoft Excel Solver printout to answer the following questions.
- What is the optimal value of the objective function? Explain what this value means and state the LP application classification this model represents.
 - How many (i) real activities and (ii) constraints does this model have?
 - What is the optimum value of each of the real and slack activities?
 - Explain the opportunity cost associated with Central, Copperbelt and Lusaka province constraints.
 - What is the reduced cost of CopEast? Over what range of CopEast's C_j is this value valid?
 - Write out the algebraic model from which this output comes
 - Why does Euler's theorem hold in LP models?

-----**END OF EXAM**-----

Happy holidays!

Microsoft Excel Solver Printout for Question 5

Row	Equation	RHS
units	CentEast CentLusa CentSour CentWest CopEast CopLusa CopSour ConWest NorEast NorLusa NorthSour North	10 30 0 30 40 10 50 0 0 0 0 0
ZK	Objective function	7,900,000
		50,000 70,000 90,000 60,000 70,000 50,000 60,000 100,000 60,000 80,000 120,000 70,000
Supply constraints (<=)		
tonne	Central Prov.	70
tonne	Copperbelt Prov.	60
tonne	Northwestern Prov.	0
		80 1 1 1 1 1 1 1 1 1 1 1
Demand constraints (>=)		
tonnes	Eastern Prov.	10
tonnes	Lusaka Prov.	40
tonnes	Southern Prov.	50
tonnes	Western Prov.	30
		10 1 1 1 1 1 1 1 1 1 1 1

Microsoft Excel 9.0 Answer Report
Worksheet: [Transportation.xls]Tableau

Target Cell (Min)

Cell	Name	Original Value	Final Value
\$C\$4	Objective function equation	0	7,900,000

Adjustable Cells

Cell	Name	Original Value	Final Value
\$E\$3	CentEast	0	10
\$F\$3	CentLusa	0	30
\$G\$3	CentSout	0	0
\$H\$3	CentWest	0	30
\$I\$3	CopEast	0	0
\$J\$3	CopLusa	0	10
\$K\$3	CopSout	0	50
\$L\$3	CopWest	0	0
\$M\$3	NortEast	0	0
\$N\$3	NortLusa	0	0
\$O\$3	NortSout	0	0
\$P\$3	NortWest	0	0

Constraints

Cell	Name	Cell Value	Formula	Status	Stack
\$C\$7	Central Province equation	70	=\$C\$7<=\$D\$7	Not Binding	10
\$C\$8	Copperbelt Province equation	60	=\$C\$8<=\$D\$8	Binding	0
\$C\$9	Northwestern Province equation	0	=\$C\$9<=\$D\$9	Not Binding	20
\$C\$12	Eastern Province equation	10	=\$C\$12>=\$D\$12	Binding	0
\$C\$13	Lusaka Province equation	40	=\$C\$13<=\$D\$13	Binding	0
\$C\$14	Southern Province equation	50	=\$C\$14<=\$D\$14	Binding	0
\$C\$15	Western Province equation	30	=\$C\$15<=\$D\$15	Binding	0
\$E\$3	CentEast	10	=\$E\$3<=0	Not Binding	10
\$F\$3	CentLusa	30	=\$F\$3>=0	Not Binding	30
\$G\$3	CentSout	0	=\$G\$3<=0	Binding	0
\$H\$3	CentWest	30	=\$H\$3>=0	Not Binding	30
\$I\$3	CopEast	0	=\$I\$3<=0	Binding	0
\$J\$3	CopLusa	10	=\$J\$3>=0	Not Binding	10
\$K\$3	CopSout	50	=\$K\$3>=0	Not Binding	50
\$L\$3	CopWest	0	=\$L\$3>=0	Binding	0
\$M\$3	NortEast	0	=\$M\$3<=0	Binding	0
\$N\$3	NortLusa	0	=\$N\$3>=0	Binding	0
\$O\$3	NortSout	0	=\$O\$3>=0	Binding	0
\$P\$3	NortWest	0	=\$P\$3>=0	Binding	0

Microsoft Excel 9.0 Sensitivity Report
 Worksheet: [Transportation.xls]Tableau
 Report Created: 4/8/02 3:13:30 AM

Adjustable Cells

Cell	Name	Final Value	Reduced Cost	Objective Coefficient	Allowable Increase	Allowable Decrease
\$E\$3	CentEast	10	0	50000	10000	50000
\$F\$3	CentLusa	30	0	70000	10000	20000
\$G\$3	CentSout	0	10000	90000	1E+30	10000
\$H\$3	CentWest	30	0	60000	10000	60000
\$I\$3	CopEast	0	40000	70000	1E+30	40000
\$J\$3	CopLusa	10	0	50000	20000	10000
\$K\$3	CopSout	50	0	60000	10000	80000
\$L\$3	CopWest	0	60000	100000	1E+30	60000
\$M\$3	NortEast	0	10000	60000	1E+30	10000
\$N\$3	NortLusa	0	10000	80000	1E+30	10000
\$O\$3	NortSout	0	40000	120000	1E+30	40000
\$P\$3	NortWest	0	10000	70000	1E+30	10000

Constraints

Cell	Name	Final Value	Shadow Price	Constraint R.H. Side	Allowable Increase	Allowable Decrease
\$C\$7	Central Province equation ✓	70	0	80	1E+30	10
\$C\$8	Copperbelt Province equation ✓	60	-20000	60	30	10
\$C\$9	Northwestern Province equation	0	0	20	1E+30	20
\$C\$12	Eastern Province equation	10	50000	10	10	10
\$C\$13	Lusaka Province equation ✓	40	70000	40	10	30
\$C\$14	Southern Province equation	50	80000	50	10	30
\$C\$15	Western Province equation	30	60000	30	10	30

Microsoft Excel 9.0 Limits Report
 Worksheet: [Transportation.xls]Tableau
 Report Created: 4/8/02 3:13:30 AM

		Target
Cell	Name	Value
\$C\$4	Objective function equation	7,900,000

Adjustable			Lower	Target	Upper	Target
Cell	Name	Value	Limit	Result	Limit	Result
\$E\$3	CentEast	10	10	7900000	20	8400000
\$F\$3	CentLusa	30	30	7900000	40	8600000
\$G\$3	CentSout	0	0	7900000	10	8800000
\$H\$3	CentWest	30	30	7900000	40	8500000
\$I\$3	CopEast	0	0	7900000	0	7900000
\$J\$3	CopLusa	10	10	7900000	10	7900000
\$K\$3	CopSout	50	50	7900000	50	7900000
\$L\$3	CopWest	0	0	7900000	0	7900000
\$M\$3	NortEast	0	0	7900000	20	9100000
\$N\$3	NortLusa	0	0	7900000	20	9500000
\$O\$3	NortSout	0	0	7900000	20	10300000
\$P\$3	NortWest	0	0	7900000	20	9300000

THE UNIVERSITY OF ZAMBIA

UNIVERSITY FIRST SEMESTER EXAMINATIONS – APRIL 2002

AGE 511

AGRICULTURAL ORGANIZATION AND ADMINISTRATION

INSTRUCTIONS: ANSWER ANY FIVE OF THE FOLLOWING QUESTIONS. EACH QUESTION IS WORTH 20%

TIME: THREE (3) HOURS

1. a) Managers are expected to have some skills. What are the three skill areas that managers should possess and apply? Cite an example illustrating the application of each type of skill area. You should also briefly comment on the skill mixtures needed by managers at various levels of management.
b) Zambia's public agricultural extension organisations can be described as bureaucratic structures. What are the major features of a bureaucratic organisation as described by Max Weber?
2. Kulima Corporation Ltd is a large agribusiness firm in Zambia with branches throughout the country. Its organizational structure is a multiple structure combining territorial, functional, customer and product departmentation. Draw an illustration showing the organizational structure of Kulima Corporation. Describe **three** of the methods of departmentation used by Kulima Corporation and clearly outline the advantages and disadvantages associated with each one of them.
3. a) Comment on theory X and theory Y. What are the managerial implications of these theories?
b) What is leadership? Comment and elaborate on the bases of leadership power.
4. Staffing is critical to the success of any organization. The staffing process involves six steps among which is Human resource planning and Orientation. Explain what Human resource planning and Orientation are, elaborating on what is involved in these activities and their relevance in terms of the staffing function.
5. a) Nkumba Enterprises Ltd is a pork processing firm which has been experiencing disciplinary cases or problems and conflicts among its junior staff in the factory. As a supervisor, you have been tasked to handle all disciplinary cases of Nkumba

Enterprises. What principles would you put in practice in order to maintain discipline among the junior staff.

- b) Outline the five principle methods of interpersonal conflict resolution you would consider for some of the cases among the junior staff.

6. Write brief notes explaining the following:

- a) Maslow's theory of human needs
- b) Unity of Command
- c) Span of Control
- d) Mission Statement
- e) Matrix Organizational Structure

END OF EXAMINATION

THE UNIVERSITY OF ZAMBIA

FIRST SEMESTER EXAMINATIONS – APRIL 2002

AGE 521 – FARM MANAGEMENT

TIME: THREE HOURS

INSTRUCTIONS: ANSWER FIVE QUESTIONS

- Q1. Discuss why Market Planning has become an integral part of modern farm management.
- Q2. The primary use of a Cashflow budget is to project the timing and amount of new borrowing the business will need during the year, and the timing and amount of loan repayments. Carefully discuss the other uses and advantages of the Cashflow budget.
- Q3. Identify the types of risk and uncertainty faced by farmers. Discuss the various safe guards farmers use against risk and uncertainty in the farm business.
- Q4. Mr. Kunda wishes to add 100 steers to his beef herd. He invests K6,000,000 in additional buildings at an annual cost of 12% of the investment; and K2,000,000 on additional equipment at an annual cost of 18% of the investment costs.

Revenue consist of steers sold at K374,000/head but 40 tonnes of hay @ K30,000/ton should be purchased to feed the additional 100 steers. Storage for this hay is available. Each steer is purchased at K216,000. Additional feed required is K70,000 maize and K15,000 supplement/head. Present labor requirement for 100 steers is on average 10 hours/head. Labour cost is estimated at K2,500/head. Veterinary and Medicine costs are K7000/head. Included interest for one steer is estimated at 16% of the purchase price. Mortality rate is estimated at 1%. If new labour requirement for 200 steers average at 8 hours/head, is it a good idea for Mr. Kunda to make this investment to enable him change from 100 to 200 steers? Discuss.

- Q5. Mr. Kabwe is thinking of opening three hectare fallow land for groundnut production. This would require eighty man-days of casual labour per hectare at K1760.00/day or hiring a tractor to do the same work at K176,000/ha. If he hires the tractor he expects to be able to plan earlier and thus increase his usual yield of 850 Kg/ha groundnuts. Seed, fertilizer and chemicals costs will amount to K167,200/ha and harvesting, parking and transport add up to K121.00/Kg.

**UNIVERSITY OF ZAMBIA
SCHOOL OF AGRICULTURAL SCIENCES**

**DEPARTMENT OF AGRICULTURAL ECONOMICS AND
EXTENSION EDUCATION**

**INTERNATIONAL AGRICULTURAL TRADE (AGE 531)
FINAL EXAMINATION**

Time: Three Hours
Instructions: The examination paper has three sections. Please follow the instructions in each section

SECTION I

Instructions: Question number 1 is compulsory

1. Zambia exports Arabica coffee to Europe and other niche markets. Suppose the border price of coffee is K10,000 per kilogram. The enterprise budget indicates that one kilogram of coffee requires 2 units of X input at the border price of K2,000 per unit and 5 units of input Y at the border price of K500 per unit.

The government protects the coffee industry through an import tariff of 20 percent on imported coffee and 10 percent on inputs. Calculate and interpret the following: (40 marks)

- a) The degree of protection of the coffee industry. (5 marks)
 - b) The protection rate of the coffee industry. (5 marks)
 - c) The effective protection coefficient. (10 marks)
 - d) The effective protection rate. (5 marks)
 - e) Discuss the impact, on coffee exports, of the widening gap between the official and Bureau de Change exchange rates. (5 marks)
 - f) Discuss the expected impact, on coffee exports, of the proposed reduction of inflation from approximately 20% to 13%. (5 marks)
 - g) Discuss the expected impact, on coffee exports, of the proposed reduction of diesel and electricity tariffs. (5 marks)
-

SECTION II

Instructions: Answer any two questions from section II

2. Briefly discuss the following: (15 marks)
 - i) Balance of payments (3 marks)
 - ii) Structural Adjustment Programme (3 marks)
 - iii) Border price (3 marks)
 - iv) Dumping (3 marks)
 - v) Terms of trade (3 marks)

 3. Trade advocates argue that trade is in the best interest of the countries involved and the world at large. (15 marks)
 - i) Briefly discuss the modern theory of comparative advantage and its differences with the classical theory of comparative advantage. (3 marks)
 - ii) Specify the Hecksher-Ohlin synthesis and its major conclusions. (3 marks)
 - iii) Briefly discuss the arguments for trade barriers. (3 marks)
 - iv) Briefly discuss the key policy instruments used to intervene in agriculture markets. (6 marks)

 4. Recently, the Minister of Agriculture and Cooperatives promised that this is the last year for Zambia to import maize.
 - i) Use the Marshallian supply and demand curves to illustrate the gains from trade. (5 marks)
 - ii) Following the expected short fall of maize production, the President of Zambia is encouraging farmers to produce grain maize under irrigation. The estimated cost of producing one 50 kilogram bag of irrigated grain maize is K30,000. On the other hand, traders have indicated that the border price of one 50 kilogram bag of imported maize is K50,000. As an economist in the Ministry of Agriculture and Cooperatives, you have been asked to determine the comparative advantage and competitiveness of irrigated grain maize production in Zambia. Be sure to interpret the results. (10)
-

SECTION III

Instructions: Answer any two questions from section III

5. Economic integration institutions are becoming very popular. (15 marks)
 - i) Using existing examples from various parts of the world, briefly discuss the different types of economic integration. (10 marks)
 - ii) The regional institutions usually adapt GATT regulations as the basis of the memorandum of understanding. Briefly discuss the acceptable agricultural trade distortions under GATT. (3 marks)
 - iii) Briefly discuss the various forms of non-tariff barriers. (2 marks)
6. Discuss the characteristics and nature of support offered by the major international trade enhancing institutions. (15 marks)
7. Sound macro-economic management is important. (15 marks)
 - i) Using examples from Zambia, discuss the key macro-economic indicators, which have been adversely affected by unsound policies. (5 marks)
 - ii) Briefly discuss the relevance of the 'Economic Degradation Process' in explaining the economic problems the country is facing. (10 marks)
 - iii) Briefly discuss the relevance of sound macro-economic policy to the Zambian agricultural sector. (5 marks)

END OF THE EXAMINATION

THE UNIVERSITY OF ZAMBIA
UNIVERSITY FIRST SEMESTER EXAMINATIONS - APRIL 2002
DEPARTMENT OF AGRICULTURAL ECONOMICS AND EXTENSION
EDUCATION
AGRICULTURAL PROJECT PLANNING AND APPRAISAL
(AGE541)

FINAL EXAM

INSTRUCTIONS: Answer **ALL** of the following **SIX** questions.

TIME: Three (3) hours

Question 1

You have been asked by the Ministry of Agriculture and Cooperatives to estimate a potentially realistic price that farmers in a maize project area in Mpongwe district should receive for their surplus maize which has a ready market in Ndola. Your assistant analyst has gathered the following details:

- . F.o.b. Joburg, South Africa white maize in bulk is \$170/ton
- . Freight and insurance to Lusaka is \$90/ton
- . Unloading into FRA sheds in Lusaka is \$5/ton
- . Official exchange rate is US\$1 = K4000
- . Government subsidy is K100 000/ton
- . Transport to Ndola (300km @ K300/ton/km)
- . Transport from a surplus maize project area in Mpongwe (150km from Ndola @ K300/ton/km)
- . Local on-farm storage costs are K40 000 /ton
- . Foreign Exchange premium is 20 per cent
- . Transport cost has 50% import content and 50% local content
- . Local shadow labor wage is 70% of market wage

Find the C.i.f. Lusaka price in Kwacha [4 marks]

Find the wholesale price of maize in Masala market in Ndola in US\$ [5 marks]

Find the import parity price at project boundary in US\$ [4 marks]

Find the economic value of maize using (i) Shadow Exchange Rate [6] (ii) Standard Conversion Factor [6]

Question 2

You are given the following project incremental net benefit stream and discount factors at 16%, 20% and 22%.

Year	Incremental Net benefit	Discount factors 16%	Discount factors 20%	Discount factors 22%
1	-3443	.862	.833	.820
2	-1334	.743	.694	.672
3	704	.641	.579	.551
4	1227	.552	.482	.451
5	1436	.476	.402	.370
6	1476	.410	.335	.303
7	1476	.354	.270	.249
8	1476	.305	.233	.204
9	1476	.263	.194	.167
10	1476	.227	.162	.137
11	1476	.195	.135	.112
12	4130	.168	.112	.092

- a. Calculate the net present worth (NPW) @ 16%; 20% and 22% and decide whether to accept or reject the project. [9 marks]
- b. Calculate the net benefit-investment ratio (N/K) @ 16%; 20% and 22% and decide whether to accept or reject the project. [9 marks]
- c. Calculate the Internal Rate of Return (IRR) for the project. [5 marks]
- d. If the project capital is borrowed at a rate of 21.35%, as an analyst, what decision action would you recommend to the investors? [2 marks]

Question 3

You are given the following information about an agricultural project which introduces irrigation cultivation and fertilizer to raise farm output and incomes. All figures are for year 1, and are expressed in financial prices and domestic currency.

Farm Budget Inflows and Outflows	Without Project	With Project
Purchase of irrigation equipment	0	18 000
Purchase of water right	0	3 000
fertilizer	0	2500
land taxes paid by farmer	1 000	1 000
wages for hired labor	5 000	500
gross value of crop production	8 000	20 000
loan receipts	1 000	15 000

Notes

- fertilizer is imported duty free and sold to farmers at a 40% subsidy
- crops produced are exported
- irrigation equipment is imported
- the shadow wage rate is 50% of the market wage rate
- domestic currency is overvalued by 20%

Calculate

- financial incremental net benefit in year 1 [9 marks]
- economic incremental net benefit in year 1 using SER [8 marks]
- economic incremental net benefit in year 1 using SCF [8 marks]

Question 4

What approach would you use in evaluating the economic benefits of a transport project in the following two cases? Give a concise account of the approach.

- the Airport turn-off to Kabwe Round About road with much commuter (visitors and residents) and truck traffic will be widened to a six lane highway [Focus on time savings (5 marks) and accident reduction benefits (10 marks)]
- road improvement (asphalt surfacing) in Ndola rural (Masaiti, Mpongwe & Lufuwanyama), a development region with much agricultural economic activities including operations of 60 000 ha Mpongwe Development Corporation [Focus on reduced operating expenses benefits (10 marks)].

Question 5

- a. Why is it important to rank projects? [5 marks]
- b. When is it appropriate to rank projects? [5 marks]
- c. Given the following information on projects A and B, (million K) calculate the N/K ratio of each project and indicate which project(s) you would accept given an opportunity cost of capital of 10%. [10 marks]

	Year 1	Year 2	Year 3 - 5
Net benefits project A	-1000	-500	1000
Net benefits project B	-1500	500	1300
Discount factor at 10%	.909	.826	2.055

- d. What are the advantages and disadvantages of net present worth as a measure of project worth? [5 marks]

Question 6

You are given the following information about two possible irrigation projects, each of which would use the same project site. Your client has a equity capital worth K10 million.

Project A: Invest K2 million IRR = 200%
Project B: Invest K10 million IRR = 60%

- a. Explain why in this case you would or would not compare the IRR's of each project in deciding which project to chose. [5 marks]
- b. Which project would you chose if the opportunity cost of capital were 21%? If it were 22%? Explain. [8 marks]
- c. Your client, Zambia Sugar has K10 billion kwacha worth of equity capital available for investment. You are provided with the following information about possible projects.

Project	Present Value of Costs	Present Value of benefits	Internal rate of return
1	2	2.6	30
2	10	12	20.5
3	8	9.42	18

Which projects will you advise that the Chief Executive Officer to select for the company's investment portfolio? Use NPW, Incremental IRR and Weighted IRR measures of project worth to answer this question[12 marks]

THE UNIVERSITY OF ZAMBIA

UNIVERSITY FIRST SEMESTER EXAMINATIONS—APRIL 2002

AGF 211

GENERAL MICROBIOLOGY

THEORY PAPER

TIME: THREE (3) HOURS

INSTRUCTIONS:

ANSWER ALL QUESTIONS.

1. (a) With the help of a well-labeled diagram, explain the fluid mosaic model for cell membrane structure.
- (b) Contrast Gram-positive and Gram-negative cell walls. What is the significance of this architectural difference?
2. Using well-labelled diagrams, show how you would obtain 38 molecules of ATP from one molecule of glucose. Explain the mechanism for oxidative phosphorylation. How is the Krebs cycle controlled in bacteria?
3. The immune system is made up of molecules and cells. Describe how the immune system works. In your answer, explain the basis of food allergies.
4. Describe lysogenic and lytic pathways in phage lambda.
5. Discuss fermentation pathways in bacteria. Why are these pathways important in food industries?
6. Describe methods used to isolate bacteria and viruses from their natural habitats.

-END OF EXAMINATION-

**THE UNIVERSITY OF ZAMBIA
UNIVERSITY FIRST SEMESTER EXAMINATIONS—APRIL 2002**

AGF 211

GENERAL MICROBIOLOGY

PRACTICAL PAPER

TIME: THREE (3) HOURS

INSTRUCTIONS: ANSWER ALL QUESTIONS

1. You are provided with bacterial specimens A and B. Stain and use the microscope to draw the shapes of the specimens. Perform the Gram stain procedure. describe the procedure in detail. and conclude whether the specimens are Gram positive or Gram negative.
2. You have been provided with two stock bacterial cultures labeled C and D. In 2.5 hours. prepare growth curves for these two bacterial cultures. Plot your results on graph paper. Comment on the growth phases for the two cultures. How is the growth curve of practical relevance to a food scientist?
3. You want to isolate a bacterial species from soil. Explain how you would go about it.

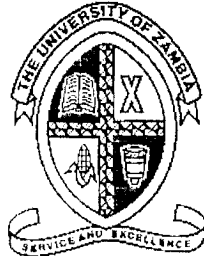

**The University of Zambia
School Of Agricultural Sciences
Food Sciences and Technology**

AGF 221 Computer Sciences

Final Examination (Theory)

Duration: 2 Hours

Date: Monday 22nd April 2002 (AM)

4. a) When learning a computer language, one needs to learn about two important aspects of the language, what are these two aspects and what do they mean? **(6Marks)**
- b) When designing a program, a computer programmer (i.e. software engineer) has at his/her disposal designing tools to use, one of them is a decision table. Can you name two other tools? **(2 marks)**
- c) Define a computer file and give an example of a computer file **(2 marks)**
5. a) What is the main use of internal memory? **(6 marks)**
- b) What word is used to describe the loss of data when power is removed from a certain type of internal memory and what type of memory is that? **(2 marks)**
- c) What is an application package and give an example of one **(2 marks)**
6.  What factors do you look for when you are buying a computer? **(6 marks)**
7. Why does a computer system need a backing storage? **(4 marks)**
8. E-mail has become popular among today's users and is facilitated through Internet.
 - a) What is Internet? **(3 marks)**
 - b) Can you list four Internet Service Providers registered in Zambia? **(4 Marks)**
 - c) What are some advantages of using Internet **(3 marks)**

Section 2 Visual Basic (30 marks)

9. The Visual Basic Integrated Environment consists of the following elements:
 - a) Project Explorer Window
 - b) Properties Window
 - c) Form Designer Window
 - d) Code window
 - e) Tool Box

Explain the function of each element. **(10 marks)**

10. Visual Basic is an event driven programming language.
 - What is an event? Give examples. **(10 marks)**
 - a. What is a control? **(5 marks)**
 - b. What is the property of a control? **(3 marks)**
 - c. What window is used to set properties of a control? **(2 marks)**

***** **END OF EXAMINATION PAPER** *****

THE UNIVERSITY OF ZAMBIA
UNIVERSITY SEMESTER I EXAMINATIONS – APRIL 2002

Methods in Food Analysis AGF 311

ANSWER ALL QUESTIONS

TIME: 3 HOURS

1. (a) A solute with a partition coefficient of 4.0 is extracted from 15 mL of phase 1 into phase 2.
 - (i) What volume of phase 2 is needed to extract 99% of the solute in one extraction?[2]
 - (ii) What is the total volume of solvent 2 needed to remove 99% of the solute in three equal extractions?[6]
 - (b) A chromatogram with ideal Gaussian bands has $t_r = 9.0$ min and $w_{1/2} = 2.0$ min.
 - (i) How many theoretical plates are present?[2]
 - (ii) Find the plate height if the column is 10 cm long.[2]
 - (c) In chromatography, why do bands spread? Use an appropriate equation to explain this.[6]
 - (d) What volume of buffer is required to dialyze a 10 mL protein sample from an ion exchange column elution pool, which contains 1.0 M NaCl? The required final salt concentration in the sample is 1 mM, i.e. NaCl.[4]
 - (e) What is microfiltration and what do you understand by Molecular Weight Cut-Off (MWCO) of a membrane?[4]
2. (a) A 0.0450 M solution of HA is 0.60% dissociated. Calculate pKa for this acid.[2]
 - (b) The acid HA has pKa = 4.00. Use α values to calculate the fraction in the form HA and fraction in the form A⁻ at pH = 5.00. Does your answer agree with what you expect for the quotient [A⁻]/[HA] at pH = 5.00?[4]
 - (c) What fraction of ethane-1,2-dithiol (HSCH₂CH₂SH) is in each form (H₂A, HA⁻, A²⁻) at pH 8.00? ($K_{a1} = 1.4 \times 10^{-9}$ and $K_{a2} = 3.7 \times 10^{-11}$)[7]
 - (d) For a diprotic acid such as H₂S, show that $\alpha_0 = [H_2S]/C = [H^+]^2 / \{ [H^+]^2 + K_1[H^+] + K_1K_2 \}$ [7]
 - (e) Distinguish between end point and equivalence point. With reference to your answer, what does the term titration error mean?[6]

3. (a) Calculate the pH at the following points for the titration of 50.00 mL of 0.0500 M formic acid ($K_a = 1.80 \times 10^{-4}$) with 0.0500 M KOH: 10.0, 25.0, 50.0, 55.0 mL. Sketch a graph of pH Vs V_b . [8]

b (b) Calculate pCa for the titration of 25.00 mL of 0.0200 M EDTA with 0.0100 M CaSO_4 at pH 10.00 at the following volumes: 20.0, 50.0, 55.0 mL. ($K_{f \text{CaY}^{2-}} = 1.0 \times 10^{12}$ and $\alpha_{Y^{4-}} = 0.054$) [6]

c (c) Calculate the cell potential for the following cell: [5]

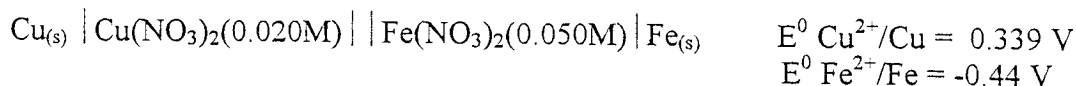

d (d) An aqueous glycerol solution weighing 100.0 mg was treated with 50.0 mL of 0.0837 M Ce^{4+} in 4 M HClO_4 at 60 °C for 15 min to oxidize glycerol to formic acid

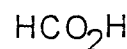
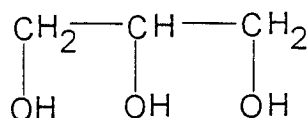

Glycerol
Mw 92.095

Formic acid

The excess Ce^{4+} required 12.11 mL of 0.0448 M Fe^{2+} to reach a ferroin end point. What is the weight percent of glycerol in the unknown? (C=12.00 ; H=1.00; O=16.00) [5]

4. (a) Describe a reasonable sample preparation technique for the analysis of each of the following analytes in Soya beans:

- (i) Atrazine (an organic herbicide used to kill weeds) [5]
- (ii) Lead (probably from use of leaded pipes, it is suspected to have contaminated the beans) [5]

(b) Why would you prefer to use a matrix matched rather than a pure standard in quantitative analysis? [5]

(c) State four desirable properties of a gravimetric precipitate. [4]

(d) A 0.05020-g sample of impure piperazine contains 71.29 wt% piperazine (MW 86.137). How many grams of product (MW 206.243) will be formed when this sample is analyzed by the following reaction? $(\text{CH}_2)_4(\text{NH})_2 + 2\text{CH}_3\text{CO}_2\text{H} \rightarrow (\text{CH}_2)_4(\text{NH}_2)_2^{2+}(\text{CH}_3\text{CO}_2^-)_2$ [5]

UNIVERSITY OF ZAMBIA
SCHOOL OF AGRICULTURAL SCIENCES
DEPARTMENT OF FOOD SCIENCE & TECHNOLOGY

April 2002

FOOD CHEMISTRY (AGF 321) – THEORY EXAMINATION

INSTRUCTIONS

1. In section I, answer any 2 questions of your choice out of the 3 provided questions. Please note that all questions carry the same number of points
 2. Section II has 2 questions and THEY are compulsory. Note that they carry the same number of points.
 3. The duration of the examination is (3) hours
 4. Note that the writing of molecular structures will not attract any marks, unless absolutely necessary. However to illustrate your points or ideas, reactions may simply be written in word form.
-

SECTION I

QUESTION 1 (25 Points)

- a) What is reversion? In which foods does it occur? **(2 Points)**
- b) Define water activity explain why it is preferred in the explanation of food perishability **(3 Points)**
- c) Why is there no enzymatic browning in intact fruit or vegetable tissues **(2 Points)**
- d) Mineral elements cannot be destroyed by heat, light, oxidising agents and extreme pH. What important aspect concerning minerals is affected by these factors? Name three important minerals required by our bodies and which should be part of our daily diet. **(3 Points)**
- e) Name three common types of caramel colours and briefly explain briefly explain how each is formed **(4 Points)**.
- f) Briefly describe 4 steps of oil refining **(4 Points)**.
- g) Name three structural polysaccharides and one storage polysaccharide **(4 Points)**.
- h) What is the difference between a dye and a lake? What do the abbreviations FD&C mean? When you see them on a label what information are they conveying to you? **(3 Points)**

QUESTION 2 (25 Points)

- a) What causes enzyme reactivation or regeneration in heat treated milk upon storage at low temperature? Name the enzyme involved and the test it is used to conduct **(3 Points)**.
- b) Name three quality defects arising from impairment of water holding capacity. Explain how one of these defects can be prevented **(4 Points)**
- c) What is a state diagram? **(2 Points)**
- d) Name three non- nutritive sweeteners **(3 Points)**
- e) Name three uses of nitrites. What is the concern for their continues use in the food industry? Explain why they are still being used **(4 Points)**
- f) What is a hydrocolloid? Name two natural and one modified **(3 Points)**
- g) What is a colorant? Name one natural and one artificial colorant **(2 Points)**
- h) When does putrefication occur in proteins? Name three important putrefication Reactions **(4 Points)**

QUESTION 3 (25 Points)

- a) What does HLB stand for? And what does an HLB of greater than 7 mean **(2 Points)**
- b) What are enzymes that hydrolyse starch called? Which of the two is referred to as a saccharifying enzyme? **(3 Points)**.
- c) Define protein denaturation mention two agents of protein denaturation **(3 Points)**
- d) Name two compounds used as phenolic antioxidants **(2 Points)**
- e) What is an emulsifier? Name two commercial emulsifiers **(3 Points)**
- f) Name three ways of ascorbic acid degradation. Mention how one can be prevented **(4 Points)**
- g) What is blanching? Which nutrients are the most susceptible to blanching? Name the enzyme used to judge the effectiveness of blanching **(4 Points)**.
- h) What is Restoration when is this done? What is enrichment name three situations in which it is used. **(4 Points)**.

SECTION II COMPULSARY (25 Points)

QUESTION 1

A Lusaka based processing company is also involved in transporting green and yellow fresh vegetables from Mwinilunga. The vegetables are supposed to be for the fresh market. It takes 8 hours to transport these vegetables from Mwinilunga to Lusaka. From the time of harvest and on the way to Lusaka they are exposed to light, heat, and abuse during handling. Identify the nutrients that these vegetables may contain. Describe the nutrients that will be most affected by the described conditions. What type of advice would you give the Processor/Transporter regarding packaging and the transportation of fresh vegetables to ensure that the products maintain their nutrients and at the same time fetch a reasonable price **(12.5 Points)**

QUESTION 2

A company has been experiencing problems concerning the keeping quality of their fat containing foods, you have been requested to advise this company on how to content this situation. The products upon being tested have a rancid and fishy taste. Identify the cause of this state of affairs and explain how this bad taste came about explain the mechanism involved from start to finish. Name the products of this mechanism if there any. Mention other negative aspects of this problem apart from the degradative sensory effect, which is already identified. Additionally name one positive aspect, which is taken advantage of in the Food Industry **(12.5 Points)**.

UNIVERSITY OF ZAMBIA
SCHOOL OF AGRICULTURAL SCIENCES
DEPARTMENT OF FOOD SCIENCE AND TECHNOLOGY

APRIL 2002

FOOD CHEMISTRY (AGF-321) PRACTICAL EXAMINATION

INSTRUCTIONS

1. Section I has only one question which is compulsory
 2. Section II has 4 questions answer any 2 of your choice. Note that all the 4 questions carry the same marks.
 3. The duration of the examination is 3 hours
-

Section I

Question (24 marks)

The kjeldahl method of crude protein determination has three major steps

- I. Sample digestion
- II. Ammonia distillation
- III. Acid titration

Explain the following in each of the three steps

(A) SAMPLE DIGESTION

- (i) Why are the following added at this step HgO, Anhydrous K_2SO_4 Concentrated Sulphuric acid (3 Points)
- (ii) If HgO and Anhydrous K_2SO_4 were not available what else would you use? (2 Points)
- (iii) Mention one effect on the method you would expect from the alternative you have suggested. (1 Point)
- (iv) Mention two factors that would affect digestion efficiency of the sample assuming the digestion temperature, HgO content, Anhydrous K_2SO_4 content and concentrated sulphuric acid were added in correct amounts (2 Points)

(B) AMMONIA DISTILLATION

- (i) Why is the digested material diluted before distillation **(2 Points)**
- (ii) What is the function of the NaOH which is added at the distillation stage **(2 Points)**
- (iii) What is the function of boric function in the receiver solution **(2 Points)**

(C) ACID TITRATION

- (i) What does the term standardisation in titration mean **(2 Points)**
- (ii) Explain why it is important to standardise the HCL used to titrate the receiver solution **(2 Points)**
- (iii) Describe the reaction of HCL and receiver solution during titration **(2 Points)**
- (iv) You have been given a food stuff whose nitrogen content is unknown explain how you would obtain its nitrogen factor so that you can use it to calculate its crude protein content **(4 Points)**

Section II

Question 1

After analysing and calculating the values of an oil sample you find that the unsaponifiable matter in the sample is 4% . How would you describe this oil in terms of its quality and of course not forgetting to mention the reasons and possible causes of this result. (**12 Points**)

Question 2

Describe and explain the principle of Drying and Distillation methods of moisture determination in foods. Give an example of foods suitable for each method. Why is it important to know the moisture content of foods? (**12 Points**)

Question 3

What is the significance of determining Total Ash?

After determination of Ash, you can determine mineral content. Why is it important to determine the mineral content of a food? Name three minerals which are important to our bodies. Name the deficiency of each should it be lacking in the diet. (**12 Points**)

Question 4

Define and explain the significance of determining the following

- a) Vitamin A (**2 Points**)
- b) Peroxide Value (**3 points**)
- c) Refractive index (**2 Points**)
- d) Free fatty acids (**3 Points**)
- e) Brix in a sugar solution and other sugar containing products (**2 Points**)

THERMODYNAMICS AGF 341 EXAM

17 April 2002

1. What is total energy? Identify the different forms of energy that constitute the total energy. (5points)
2. Determine the specific internal energy and specific volume of saturated liquid water and dry saturated steam at 307 °C. (tables). (10points)
3. Determine the specific enthalpy of steam at 0.77 Mpa and 380°C. (tables).
4. A supply of 50 kg of chicken at 6°C contained in a box is to be frozen to -18°C in a freezer. Determine the amount of heat that needs to be removed. The latent heat of the chicken is 247 kJ/kg, and its specific heat is 3.32 kJ/(Kg.°C) above freezing and 1.77 kJ/(kg.°C) below freezing. The container box is 1.5 kg, and the specific heat of the box material is 1.4 kJ/(kg.°C). Also the freezing temperature of chickens is -2.8°C. (25points)
5. How does forced convection differs from natural convection? Give an example. (5points)
6. What are the characteristics of all heat engines? Describe two ways to determine the net work output of a heat engine. (10 points)
7. How does the ideal-gas refrigeration cycle differ from the Carnot refrigeration cycle? Compare and discuss the efficient in both cases. Draw a graph of the processes. (10 points)
8. A refrigerator uses refrigerant 134a as the working fluid and operates on an ideal vapour-compression refrigeration cycle between 0.12 and 0.7 MPa. The mass flow rate of the refrigerant is 0.05 kg/s. (25 points)
 - a) Show the cycle on a T-s diagram with respect to saturation lines
 - b) Determine the rate of heat removal from the refrigerated space and the power input to the compressor
 - c) The rate of heat rejection to the environment
 - d) The coefficient of performance.

FOOD ENGINEERING AGF 411 EXAM.

19 April 2002

Please read carefully the questions before answering. STRICTLY ANSWER TO THE QUESTIONS ONLY. DO NOT OVERWRITE. ANSWER PAPERS SHOULD BE CLEAN. STRICTLY FOLLOW THE ORDER OF THE QUESTION.

1. Raw milk is transported to a dairy for processing and is fed through a centrifugal separator to remove the milk fat. The separator uses 3650 kg/hr of feed which has a composition of 85.5% water, 4.4 % Carbohydrate, 3.9% Fat, 3.4 % Protein, 0.8 % Minerals. The resulting products are a non-fat stream and a cream stream. The cream has a composition of 98 % fat and 2 % water. A portion of the cream stream is then added back to the non-fat stream to yield 2 % fat milk. (20 points)
 - a) Draw and label a schematic of the process
 - b) Determine the flow rate of the cream and non fat streams from the separator
 - c) Determine the amount of cream required to be added back to the nonfat stream to yield 2% fat product.

2. Water is flowing in a 2'' pipe at a rate of 10kg/min. The pipe suddenly narrows to ¾'' diameter. (15 points)

What is the new:

 - a) Mass flow rate
 - b) Volumetric flow rate
 - c) Average velocity.

3. How would the Reynolds number for liquid flow in a pipe change for each of the following
 - a) Increasing fluid viscosity;
 - b) Decreasing pipe diameter with a constant velocity;
 - c) Increasing the specific heat of the fluid;
 - d) Increasing the mass flow rate of the fluid all else constant;
 - e) Decreasing the thermal conductivity of the fluid, all else constant. (20 points)

4. A co-current flow heat exchanger is available to heat a liquid food (specific heat 4.02 kJ/kg°C) from 5°C to 140°C. Steam enters at 475 kPa and exists as condensate at the same pressure. The overall heat transfer coefficient is 1000W/m² °C. Internal diameter of the pipe is 10 cm and the length of the heat exchanger is 2m. (25 points)
 - a) Sketch the heat exchanger and the temperature plot
 - b) Determine the rate of heat transfer to the product
 - c) Determine the product flow rate

- d) Would it be advantageous to run the system in a countercurrent mode? Why or why not?
5. Milk with a 2% fat content is pasteurized by pumping from a surge tank with a globe valve at the exit through a 5 cm diameter pipe at 0.5 m/s to a parallel heat exchanger (where it is heated and cooled) and then up 3 meters to a final storage tank. The milk has a density of 1035 kg/m^3 and viscosity of 0.0025 Pa s . (20 points)
- Draw a schematic of the system
 - Determine the Reynolds number for flow in the pipe, what is the flow type?
 - Starting with Bernoulli equation, how would you determine pump power requirements for the system you sketched in part a). Clearly state assumptions such as terms, which may be dropped, and the steps needed to solve the problem. Be as complete in your answer as possible. **DO NOT TRY TO SOLVE A NUMERICAL PROBLEM.**

THE UNIVERSITY OF ZAMBIA

**UNIVERSITY FIRST SEMESTER FINAL EXAMINATIONS
APRIL 26th 2002**

**COURSE: AGF 431
NUTRITION**

TIME: 3 HOURS

INSTRUCTIONS: READ THE QUESTIONS CAREFULLY AND ANSWER AS INSTRUCTED. NOTE THAT THE QUESTIONS HAVE COMPONENTS AND CHOICE HAS BEEN INCORPORATED WITHIN MOST QUESTIONS.

- 1 Give brief answers to four (4) of the following:
- a) Define the term food. List the components of Food and define their major characteristics? (5)
 - b) Complete the table below:

	Cereal	Legume	Meat	Vegetable
Important nutrient constituent				
Function				

- c) What are the biologically active (anti-nutrients) compounds in soybeans and how are they neutralized? (5)
- d) What are the main functions of the B vitamin complex and the trace elements (minerals)? (5)
- e) Define the mechanism of enzyme action and their functional models in physiological reactions. (5)

(20 points)

- 2 With the help of floor charts illustrate the following:
- a) Mechanism of vitamin D function in calcium metabolism. (5)
 - b) Select one B-vitamin and give 3 main functions, 2 major deficiency symptoms and two sources. (5)
 - c) Choose three (3) of the following vitamins: Thiamine, Riboflavin, Niacin, Pyridoxine and Folic acid, name two antagonists and how they function. (5)
 - d) Illustrate the absorption and hormonal control of Sodium (Na), Chlorine (Cl) and Potassium (K) absorption in the intestines. (5)

(20 points)

- 3 a) In protein evaluation, what is chemical score? The results from amino acid analysis for a test protein are presented in the following table:

Essential amino acid profile	Egg protein	Test Protein
Methionine	0.75	0.56
Lysine	0.58	0.31
Phenylalanine	0.95	0.62
Cystein	0.66	0.43
Valine	0.88	0.67

- i) Calculate the chemical score of the test protein.
 ii) Contrast chemical score with biological value. Name one advantage and a disadvantage of each of the two methods? (8)
- b) How is hunger and appetite controlled? Name and define the basic sensations of taste and flavor? (6)
- c) What is basal metabolic rate (BMR)? What factors affect BMR? (6)
 (20 points)

4. In estimating energy expenditure, direct and indirect calorimetry can be used.

- a) Differentiate direct from indirect calorimetry.
 What are the basic principles on which they are founded? (5)
- b) The data collected from the Carbon and Nitrogen balance of a manual worker is given as follows:

Item	C(g)	N(g)	E kcal
Food intake	950	55	9425
Excreted in feces	388	18.5	3800
Excreted in urine	47	35.5	502
Excreted as CO ₂	385	-	-

Calculate:

- a) The carbon and Nitrogen balance of the worker.
 b) The metabolizable energy from the food he ate.
 c) Protein and carbon stored if any.
 d) Protein oxidized.
 e) Net energy for production.
 f) Total heat produced.
 g) Net energy maintenance.

(15 points)

Assume the following:

Heat increment = 15%

Carbon in fat = 74.6%

Carbon in protein = 51.2%

5. Briefly discuss **components a, b and c** and then chose **d or part e** of the following:
- a) What factors contribute to adaptation to gain or loss in body energy? (4)
 - b) Define protein energy malnutrition (PEM). (4)
 - c) There are two adult men, both weighing 70kg, one is 1.8m in height the other 1.4m. Calculate their Body Mass Index (BMI). What is their nutrition status? (6)
 - d) With the help of a flow chart, differentiate the etiology (development of clinical symptoms) of kwashiorkor from those of marasmus. How do you rehabilitate malnourished children? (6)
- or**
- e) Define nutritional surveillance according to WHO or UNICEF classification. What is the importance of the data generated in Nutritional Surveys studies? (6)

END OF EXAMINATION

UNIVERSITY OF ZAMBIA
SCHOOL OF AGRICULTURAL SCIENCES
DEPARTMENT OF FOOD SCIENCE & TECHNOLOGY

April 2002

WATER AND FOOD WASTES TREATMENTS (AGF-441)
THEORY EXAMINATION

INSTRUCTIONS

1. In section I answer any two (2) questions of your choice out of the three (3) provided questions. Note that all questions carry the weight of points.
 2. Section II has only one question which is compulsory.
 3. The Duration of the examination is three (3) Hours.
-

SECTION I

QUESTION 1 (20 MARKS)

- (a) What is composting? What is the purpose of composting? Describe the composting conversion process. **(6 Points)**.
- (b) Name three recovery products of activated sludges and what is the economic significance of these products **(4 points)**
- (c) What is a Hazard? Why is it important to identify potential hazards in a processing plant? **(5 points)**
- (d) Name 5 pathogens potentially present in composites and the diseases they are likely to cause **(5 points)**

QUESTION 2 (20 MARKS)

- (a) Why is hygienic design of a factory important? Mention at least 4 areas in hygienic design which should be constructed with care to ensure that the factory functions efficiently **(5 Points)**.
(5 Points).
- (b) Explain what is involved in patenting. Explain what is involved in Systems with Mandatory pre-examination and Systems without Mandatory pre-examination **(5 Points)**.
- (c) Name three types of specialized sludges **(Points) 3**
- (d) Define what Plant sanitation is? Name two levels of performance assessment in a sanitation programme. State why they are important **(7 points)**.

QUESTION 3 (20 MARKS)

- (a) What is the purpose of involving genetic engineering in environmental biotechnology? What is a cloned gene? **(5 points)**
- (b) In the sanitation programme the cleaning phase has three sections mention them. **(3 Points)**
- (c) What are Windrow systems? Differentiate between Passively aerated and actively aerated windrows **(3 Points)**
- (d) Mention 4 factors controlling the efficiency of disinfectants **(4 Points)**
- (e) Name three animal by products and two plant by products **(5 Points)**

SECTION II

QUESTION 1 (20 MARKS)

Describe in detail the water treatment process at Iolanda from the inlet up to the transmission stage. Indicate clearly where this water goes.

THE UNIVERSITY OF ZAMBIA¹

AGG311 EXAMINATION

APRIL 2002

INSTRUCTIONS

1. Maximum time allowed = 3 hours
2. Answer Question 1 and any three other questions
3. The marks for each question are indicated at the end of the question
4. Some formulas which may be useful are given in Appendix A

1. You are asked to help design an experiment to test the effect of calcium, applied as Gypsum at 0, 50, 70 and 100 Kg/ha on the yield of irrigated groundnuts. You also need to evaluate the effect of irrigation frequency on the yield. You decide to use three irrigation intervals of 3 days, 5 days and 7 days. Explain in detail how you would use a split-plot design to achieve this. Pay particular attention to:

- The treatment structure
- Organisation of data. If possible give a table format of the data.
- The analysis of the data. If possible give a format of the analysis

[40 marks]

2 a) Explain briefly the difference between inductive and deductive reasoning in experimentation. [5 marks]

b) Give some of the properties of the mean of a sample. [5 marks]

c) Calculate the mean and standard error of the mean for the following data: 3.1, 3.5, 3.7, 3.6, 3.7, 2.7, 4.4, 4.8, 4.9, 3.9, 4.2. [10 marks]

3. An experiment was carried out among three maize varieties to compare their resistance to disease X. Individual maize plants were counted and scored three weeks after artificial inoculation with the disease. Do the following data indicate that there were differences in the reaction of the varieties? [20 marks]

Variety	Disease reaction (plants counted)			
	No symptoms	Slight symp- toms	Severe symp- toms ³	
1	108	52	40	
2	87	51	62	
3	112	39	49	

¹ Damsels and lads, it has been a pleasure, more rather than pressure, learning Biostatistics together. I hope you will enjoy giving expert advice in the design and analysis of experiments. I wish you everything of the best in this and all other exams--CG

4. Maize production varies with the amount of rainfall. Suppose that the data in the table below represents the annual total production in a country, Z, (in million tons).

Year	Rainfall (mm), x	Production (Mt), Y
1	500	55
2	720	60
3	440	50
4	300	30
5	960	75
6	780	70
7	840	70
8	620	55
9	560	30
10	660	35

- a. Calculate the coefficient of correlation, r. [7 marks]
 b. Fit a straight line to the data with rainfall as the independent variable. [13 marks]
5. You are told that an experiment was carried out involving 28 treatments. Each treatment was replicated three times ($r = 3$). You are given that an ANOVA has already been carried out as presented in the table below.

Source of variation	Degrees of freedom	Sum of squares	Mean square	F- value
Total	83	655.09		
Replication	2	0.64	0.319	0.05
Treatment	27	305.66	11.321	1.75
Error	54	348.80	6.459	

Without bothering about all the other treatments, separate the six means presented below, which were part of the experiment. Use an LSD test at $p = 0.05$. [20 marks].

Mean	Value
1	4.167
2	3.044
3	4.558
4	5.947
5	1.967
6	2.953

6. Analyse the following data as an RCBD. [20 marks]

Treatment	Replication			
	1	2	3	4
1	330	288	295	313
2	372	340	343	341
3	359	337	373	302

APPENDIX A: LIST OF USEFUL FORMULAS²

1. $LSD = t \cdot \sqrt{(2s_E^2/r)}$
2. $SS_{\text{trt}} = \sum T^2/b - CF$
3. $SS_{\text{Rep}} = \sum B^2/t - CF$
4. Expected frequency = column total X row total / grand total
5. Regression: $t_0 = b_1 / [\sqrt{(s_E^2/s_{xx})}]$
6. Regression: $b_0 = (\sum y - b_1 \sum x) / n$
7. Regression: $s_E^2 = SS_E / (n-2)$
8. Regression: $SS_E = S_{yy} - b_1 S_{xy}$

² Damsels and lads, with this, you have a real life situation: memorisation of formulas is not the problem, but their use!!! Bye

THE UNIVERSITY OF ZAMBIA
UNIVERSITY FIRST SEMESTER EXAMINATIONS
APRIL, 2002

AGS 211: FUNDAMENTALS OF SOIL SCIENCE I

TIME: 3 HOURS

MARKS : 100

INSTRUCTION: ANSWER ALL QUESTIONS AND WRITE LEGIBLY. HAND CALCULATIONS ALLOWED

- 1.(a) Examine the following data and determine whether or not the population grew exponentially.

Year:	1965	1970	1975	1980	1985	1990	1995
Population (m)	15.9	17.9	20.1	22.7	26.0	29.0	32.5

[5]

- (b) How can the study of Soil Science help increase food production in Zambia ?

[10]

2. Why do the following processes make soil parent material unstable and susceptible to weathering?

[10]

- α (a) hydration (b) Solution
(c) carbonation (d) hydrolysis
(e) Red/Ox

3. (a) Describe the origin of charge in soil.

[10]

- (b) Which of the following substances in each pair is likely to have the greater water holding capacity and why?

[4]

- (i) sandy clay/sandy loam
(ii) montmorillonite/kaolinite

4. (a) A dried undisturbed soil sample in a steel core measuring 2.5 cm in diameter and 1.0cm in height weighs 6.383g. Calculate the bulk density.

[3]

- (b) If the soil contains 1.2% organic matter and C/N ratio of 15:1, how much total N is contained in the plough layer?

[5]

- (c) Given that organic matter decomposes by first order kinetics releasing NO_3^- at a rate of 0.925 week^{-1} , how much nitrogen would mineralize after four months? Would this amount meet the maize crop requirement of 120 kg N ha^{-1} ? [10]
- 5 (a) What is the significance of pore space and particle size distribution in soil? [5]
- (b) Given that the volumetric water content of the soil to a depth of 30cm is 26%, to what depth will this water wet the soil? [4]
6. Discuss the influence of parent material, vegetation and climate on pedogenesis, citing specific examples from Zambia. [10]
7. (a) After 20 years of growing maize with ammonium sulphate fertilizer, the pH dropped from 7.0 to 5.5. Why? [5]
- (b) If we continue to burn oil, wood and coal we might increase the CO_2 in the atmosphere by 1.5 times. How may this affect weathering [5]
- (c) What evidence do you have that production of CO_2 and NO_3^- in soil are biological processes? [4]
8. (a) Carbon dioxide from soil respiration can be trapped in KOH to give KHCO_3 , which can be titrated with 0.5 M HCl. How much volume of the acid would be equivalent to 22 mg CO_2 and 6 mg C? [5]
- (b) The following reaction equation represents a titration of soil digest in the determination of N by the Kjeldahl method.

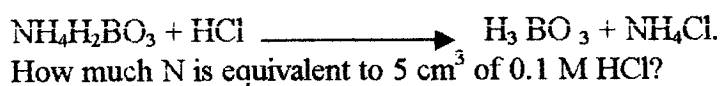

END OF EXAMINATION

**UNIVERSITY FIRST SEMESTER EXAMINATIONS
APRIL, 2002**

AGS 311: AGRICULTURAL CLIMATOLOGY

TIME: 3 HOURS

INSTRUCTIONS: ANSWER ALL QUESTIONS. ALL QUESTIONS CARRY EQUAL MARKS. CALCULATOR'S GRAPH PAPERS AND WORK ARE ALLOWED.

QUESTION ONE (1)

- a) Rainfall is one of the important meteorological parameters collected at an agro meteorological station. Besides the rainfall recorder, the standard rain gauges are also used to measure rainfall.
- i. Give an explanation of how the standard rain gauge is set up and works.
 - ii. What are the sources or error of the instrument?
 - iii. What is the significance of rainfall observation?
- b) Answer the following,
- i. What is Evapo-transpiration?
 - ii. What is Reference or Potential Evapo-transpiration, ETO?
 - iii. Name the four methods proposed by FAO (Doorenbos and Pruitt, 1977) for Calculating ETO?
- c) Answer the following
- i. How is soil temperature measured?
 - ii. What factors affected - Soil heat flux?

QUESTION TWO (2)

- a) Why is available meteorological data first checked before it is used to derive planning and design criteria?
- b) A test run is used for what purpose on temperature data?
- c) When does it become necessary to adjust climatological data?
- d) What would cause non- homogeneity of rainfall data?
- e) What does a double mass curve analysis involve?

QUESTION THREE (3)

- a) Humidity is one important climatological observation that has a lot of effect on crop water requirements.
- i. How is the saturation deficit related to actual vapour pressure?
 - ii. What is that the dew point temperature? How can one use dew point temperature to derive humidity?
 - iii. Given that saturated vapour pressure at 37.8 mbar and actual vapor pressure at 20.0 mbar. Calculate the corresponding relative humidity (RH)?

QUESTION FOUR (4)

You have just been appointed as an Agro-climate Consultant and required to establish a meteorological station and supply it with all the instruments and materials needed.

- a) Therefore prepare a brief of recommendations you can make bearing in mind that the station is to be set up on a large sugar estate?
- b) Answer the following
- i. What is the K_c (Crop coefficient) of a crop?
 - ii. What are the four factors affecting the value of K_c ?
 - iii. What factors affect the value of the fraction (p) of the available soil water?
- c) What is effective rainfall and how does it differ from dependable rainfall?
- d) Answer the following
- i. What is the maximum yield of a crop and what factors determine it?
 - ii. Name two methods that can be used to determine the maximum yield of a crop?
- e) Explain how an observation or measurement of evaporation can be done after it has just rained before making the observation?
- f) Why do you think a pan correction factor is used and applied to observations made from the evaporation at a meteorological station?

QUESTION FIVE (5)

You are required as an Agro-climatologist involved in crop forecasting to explain and determine the following.

- a) Water Requirement Satisfactory Index (WRSI)
- b) A dekad
- c) Yield (Y) and Water Requirement Satisfaction Index (WRSI)
 - i. Between two variables yields and WRSI, which is the independent variable and the dependant variable. Explain how these are determined?
 - ii. Given a relationship, **Yield (Y) = 200 + 34 (WRSI)**, Explain the meaning of 200 and 34 respectively?
- d) Presented with FAO Agro meteorological rain fed crops monitoring sheets, Table 1 below, which entries and wrong calculations can you detect then correct in lines.
 - i. Line (four) 4
 - ii. Line (six) 6
 - iii. Line (eight) 8 and
 - iv. Line (ten) 10

**Table 1. FAO AGROMETEOROLOGICAL RAINFED CROPS MONITORING.
Sheet 1.(Sample)**

No	Dekad/ Month	P _N	P _A	d _a	ER	PET	Kc	WR	P-WR	Ra	S/D	i
1	1/11	15	40	2	32	60	.35	21	11	11	0	100
2	2/11	17	29	3	23	60	.35	21	2	13	0	100
3	3/11	20	46	4	37	60	.52	31	6	19	0	100
4	1/12	24	47	2	38	61		45		12		100
5	2/12	5	1	4	61	61	.94	57	-53	0	-41	92
6	3/12	21	0	0	0		1.05	64		0		80
7	1/1	22	17	1	14	60	1.05	63	-49	0	-49	71
8	2/1	23	0	0	0	60	1.05	63		0	-63	
9	3/1	25	160	3	128	58	1.05	61	67	65	2	59
10	1/2	25	200	4	160		.92	52		65		
11	2/2	24	128	3	102	53	.71	38	64	65	64	56
12	3/2	16	8	1	6	53	.50	27	-21	44	0	56
13												
14												
15	Soil water retention capacity = 65.0 mm.											
16	Total water requirements = 543 mm.											

- (e) Given that the average best 3 yields in the area is 40 bags of maize make and predict the in the last dekad given the percentage yields in relation to the average of best three as presented in Table 2 below.

Table 2. Percentage of Yield in relation to the average of the best 3 years

% Yield	Comment	Index
>100	Very Good	100
90 -100	Good	95 - 99
50 - 90	Average	80 - 94
20 - 50	Mediocre	60 - 59
10 - 20	Poor	50 - 59
<10	Complete Failure	<50

END OF EXAMINATIONS

THE UNIVERSITY OF ZAMBIA

UNIVERSITY FIRST SEMESTER EXAMINATIONS – APRIL 2002

AGS 411 SOIL FERTILITY

TIME: 3 HOURS

MARKS: 60

INSTRUCTIONS: ANSWER ALL QUESTIONS AND WRITE LEGIBLY

1. Give five (5) different systems of fertilizer classification [5]
2. (a) Calculate N mineralization given the following information:
Total soil N = 0.15%
Mineralization rate = 4% per year
Weight of soil in top 20cm = 25×10^3 kg/ha [2]
- (b) Briefly discuss all the means by which N is lost from the soil. [8]
- (c) Why is ammonium sulphate acidifying? [2]
3. (a) What is PAPR and what are its advantages and disadvantages over SSP or TSP? [4]
- (b) What are the differences in terms of reactions and availability of N and ^P in the soil? [2]
- (c) After adding soluble P to soils you may expect precipitation, adsorption and occlusion of P to take place. Explain how and under what conditions these reactions may take place. [6]
4. Give three (3) types of Potassium fertilizers and explain how they are manufactured [6]
5. (a) What is Organic (Farming) Agriculture [2]
- (b) What is Agroforestry and how does it contribute to better soil management? [6]
- (c) What is sustainable agriculture? [2]

- 6 (a) List and discuss four (4) conditions under which Zn deficiencies may develop. [4]
- (b) List four (4) deficiency symptoms of Zn. [2]
- (c) How much zinc sulphate will be required to fertilize a 0.67 ^{fold} hactres at the rate of 5kg Zn/ha? Given: Zn in zinc sulphate = 36% [2]
7. Discuss the major differences between the soils of Northern Zambia and those of Southern Zambia [5]
8. What is isomorphous substitution and how does it contribute to the fertility of the soil. [2]
-

END OF EXAMINATION

THE UNIVERSITY OF ZAMBIA
FIRST SEMESTER EXAMINATIONS
APRIL, 2002

AGS 431
SOIL MINERALOGY AND MICROMORPHOLOGY

TIME: 3 HOURS

ANSWER ALL QUESTIONS AND WRITE LEGIBLY

1. Define the following terms

- a) Crystal habit
- b) Sesquioxide
- c) Axis of symmetry
- d) Complete extinction
- e) Pleochroism
- f) Mineral
- g) 1:1 type layer silicate mineral
- h) Goethite (Include formula)
- i) Gibbsite (Include formula)
- j) Ferralitization

(20 marks)

2(a) Identify and list the symmetry elements present in the wooden crystal model that you have been given.

(7 marks)

(b) Using the table attached to your question sheet, identify the crystal system and crystal class to which the model belongs.

(3 marks)

(c) How many optical axes would you expect a transparent mineral with the crystal structure of the wooden model to have? Give reasons to support your answer.

(5 Marks)

(d) Would you expect a transparent mineral with the crystal structure of the wooden model to polarize light? Give reasons to support your answer.

(5 marks).

3 Indicate whether the following statements are true or false.

a) Bragg's equation is $n\lambda = d\sin 2\theta$

b) The optical microscope is used to identify the mineralogical composition of the clay fraction of soils.

- c) Apatite [$\text{Ca}_5(\text{PO}_4)_3(\text{Cl}, \text{F}, \text{OH})$] belongs to the hexagonal system. It is therefore anisotropic and biaxial.
- d) Calcite and aragonite are both represented by the chemical formula CaCO_3 , though they belong to different crystal systems. These two minerals are therefore, polymorphs.
- e) Aragonite belongs to the orthorhombic crystal system, therefore it has one optical axes along which light is not polarized. (10 marks)

4. Imagine you were the head of a soil analytical laboratory, which amongst other services provides mineralogical analyses of soil samples using X – ray diffraction. While you are attending a conference in Egypt, you receive an e-mail from your staff requesting your assistance to find out whether the mineral thernadite (Na_2SO_4) is present in a sample of white salt crusts from Chipata, submitted to your lab by your former Dean at UNZA ,Professor Lungu.

What 2θ values would you advise your staff to look for on the X- ray diffractogram for the peaks of thernadite if its prominent d-spacings are 0.47nm and 0.279nm? Assume your X-ray equipment uses $\text{Cu}_{\text{K}\alpha}$ radiation with a wavelength of 0.154nm.

Show calculations to justify your choice of the 2θ values you would recommend your staff to look at, for the two-thernadite peaks. (10 marks)

5. a) A crystal face has the Miller indices $(0 \bar{1} 3)$. Describe the relationship of this face with the crystallographic axes a, b and c. (5 marks)

b) Kaolinite losses 14% of it's mass at 550°C due to the loss of its hydroxyl ions. A graph from a Thermal Gravimetric Analyzer(TGA) of a 200mg sample of clay shows a weight loss of 25 mg at 550°C . Assuming the weight loss at 550°C in this sample is solely due to kaolinite; answer the following:

- i) Calculate the amount of kaolinite present in the sample
- ii) Calculate the percent of kaolinite in the sample. (10 marks)

6. a) What is isomorphous substitution? (3 marks)

b) Explain how isomorphous substitution affects chemical properties of different phyllosilicates and consequently of the soil in which they occur. (5 marks)

List the six- (6) types of silicate minerals found in soils and give one example of a mineral species belonging to each of these types of silicates. (6 marks)

7. Discuss X-ray diffraction, elemental analysis and differential thermal analysis as physical methods of studying soil minerals, by comparing one with the other. (6marks)

End Of Examination

Table 2-4. The thirty-two crystal classes

#	Axes				Planes	Center	Hermann-Mauguin Symbols	Class Name	System
	2-Fold	3-Fold	4-Fold	6-Fold					
1	—	—	—	—	—	—	1	Pedial	Triclinic
2	—	—	—	—	—	yes	$\bar{1}$	Pinacoidal	
3	—	—	—	—	1	—	<i>m</i>	Domatic	Monoclinic
4	1	—	—	—	—	—	2	Sphenoidal	
5	1	—	—	—	1	yes	2/ <i>m</i>	Prismatic	
6	1	—	—	—	2	—	<i>mm</i> 2	Orthorhombic pyramidal	Orthorhombic
7	3	—	—	—	—	—	222	Orthorhombic disphenoidal	
8	3	—	—	—	3	yes	2/ <i>m</i> 2/ <i>m</i> 2/ <i>m</i>	Orthorhombic dipyramidal	
9	—	1	—	—	—	—	3	Trigonal pyramidal	(Trigonal)
10	—	1	—	—	—	yes	$\bar{3}$	Rhombohedral	
11	—	1	—	—	3	—	3 <i>m</i>	Ditrigonal pyramidal	
12	3	1	—	—	—	—	32	Trigonal trapezohedral	
13	3	1	—	—	3	yes	$\bar{3}$ 2/ <i>m</i>	Trigonal scalenohedral	
14	—	1	—	—	1	—	$\bar{6}$	Trigonal dipyramidal	
15	—	—	—	1	—	—	6	Hexagonal pyramidal	Hexagonal
16	—	—	—	1	1	yes	6/ <i>m</i>	Hexagonal dipyramidal	
17	3	1	—	—	4	—	$\bar{6}$ <i>m</i> 2	Ditrigonal dipyramidal	
18	—	—	—	1	6	—	6 <i>mm</i>	Dihexagonal pyramidal	
19	6	—	—	1	—	—	622	Hexagonal trapezohedral	
20	6	—	—	1	7	yes	6/ <i>m</i> 2/ <i>m</i> 2/ <i>m</i>	Dihexagonal dipyramidal	
21	1	—	—	—	—	—	$\bar{4}$	Tetragonal disphenoidal	Tetragonal
22	—	—	1	—	—	—	4	Tetragonal pyramidal	
23	—	—	1	—	1	yes	4/ <i>m</i>	Tetragonal dipyramidal	
24	3	—	—	—	2	—	$\bar{4}$ 2 <i>m</i>	Tetragonal scalenohedral	
25	—	—	1	—	4	—	4 <i>mm</i>	Ditetragonal pyramidal	
26	4	—	1	—	—	—	422	Tetragonal trapezohedral	
27	4	—	1	—	5	yes	4/ <i>m</i> 2/ <i>m</i> 2/ <i>m</i>	Ditetragonal dipyramidal	
28	3	4	—	—	—	—	23	Tetartoidal	Isometric
29	3	4	—	—	3	yes	2/ <i>m</i> $\bar{3}$	Diploidal	
30	3	4	—	—	6	—	$\bar{4}$ 3 <i>m</i>	Hextetrahedral	
31	6	4	3	—	—	—	432	Gyroidal	
32	6	4	3	—	9	yes	4/ <i>m</i> $\bar{3}$ 2/ <i>m</i>	Hexoctahedral	

THE UNIVERSITY OF ZAMBIA

UNIVERSITY FIRST SEMESTER EXAMINATIONS

APRIL, 2002

AGS 441: AGRICULTURAL HYDRAULICS AND HYDROLOGY

TIME: 3 HOURS

INSTRUCTIONS: ANSWER ALL QUESTIONS. ALL QUESTIONS CARRY EQUAL MARKS. CALCULATORS, GRAPH PAPERS AND WORK SHEETS ARE ALLOWED.

QUESTION ONE (1)

For a long time an agricultural catchment has been interfered with by small-scale farmers impacting on the natural water cycle, which in turn has interfered with the whole complex processes involved in forming a natural equilibrium.

- (a) How would you represent a water balance of a cultivated field in this catchment?
- (b) What factors would affect surface run-off in this catchment?
- (c) If there was a small stream in this catchment, how would you estimate the peak flow and what factors would affect it?
- (d) Hydrography is a very important aspect of soil and water engineering conversation and therefore would have a relevant in this catchment, how would you describe the unit hydrography of this catchment?
- (e) Given that 900 mm is used for irrigation, 250 mm comes from rainfall and 100mm and 500mm is direct evaporation and transpiration respectively with 900mm going into soil moisture and of which 50mm is capillary rise and 450 is beneficial irrigation
Illustrate with an aid of a diagram an agro-water balance

- i. Estimate the surface run-off, seepage and crop uptake amounts?
- ii. Mention the methods you may use to determine evapo-transpiration and precipitation of the catchment?
- iii. How would you reduce the run-off induced by the small-scale farmers?

QUESTION TWO (2)

The two most common means of exploring ground water for agricultural purposes and surveying the resources is to drill a borehole and to pump water from it to a depth of normally 50 - 200 metres deep and constructed using drill bits that are capable of breaking up the underground soils and rocks.

- (a) What would be the difference between a confined and unconfined aquifer if both were found in the area?
- (b) What two methods are commonly used in Zambia to drill boreholes?
- (c) How would you describe the following;
- i. Steady flow in an aquifer?
 - ii. Unsteady flow in an aquifer?
 - iii. Radius of influence of a borehole?
 - iv. Losses of energy in a pipeline if water had to be pumped from the borehole?
- [d] A Borehole is 0.3cm in diameter and penetrates 30m below the static water level. After a long period of pumping at a rate of 30l/s, the drawdown in the borehole is found to be 3.6m and 2.25m respectively.
- i. What is the permeability of the aquifer?
 - ii. What is the drawdown in the pumped well?
 - iii. What is the radius of influence?
- [e] Although in many respects pumping water for irrigation is similar to that for drainage, requirements differ.
- i. What are performance characteristics of a pump?
 - ii. List three types of pumps?
 - iii. List types of centrifugal impellers?
 - iv. What is the selection criterion of centrifugal pumps?

QUESTION THREE (3)

There is no shear force in a liquid at rest but, when it is in motion, shear forces can be set up due to viscosity and turbulence, which oppose motion, producing a frictional effect. Many problems can be solved, at least partially by assuming an ideal frictionless (in viscid) fluid.

- (a) Describe two distinct types of flow which occur
- (b) Define the following terms used in connection with the flow of a liquid
- i. Uniform flow?
 - ii. Steady flow?
 - iii. Unsteady flow?
 - iv. What is meant by continuity of flow and under what conditions does it occur?
- [c] Water for irrigation flows through a pipeline in Figure 1 below which contracts from 450mm diameter at A to 300mm diameter at B and then forks, one branch being 150mm diameter discharging at C and the other

branch 225mm diameter discharging at D. If the velocity at A is 1.8m/s and at D is 3.6m/s what will be the discharges at C and D and the velocities at B and C?

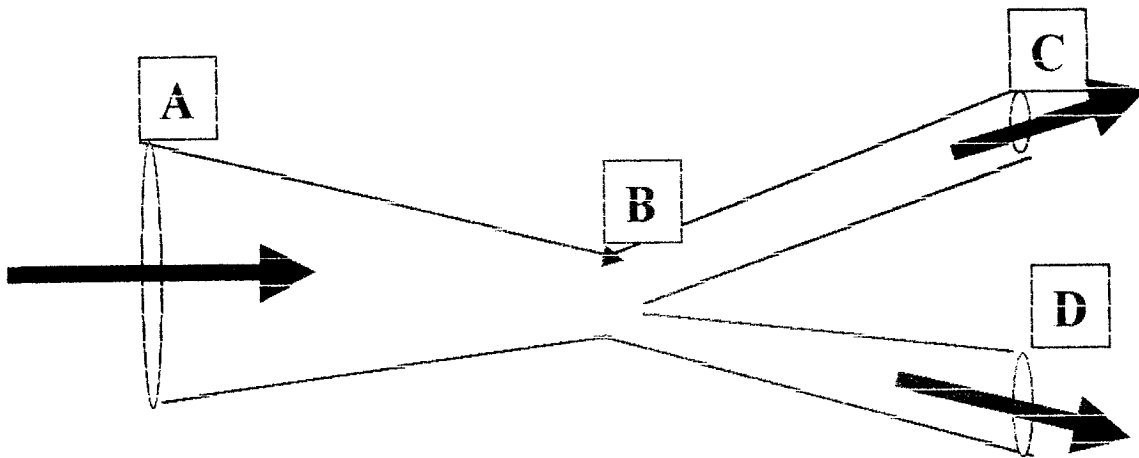

Figure 1. Branched pipe network

- [d] Which flow measuring devices apply Bernoulli's equation to the measurement of flow?
- [e] What is a notch? If the discharge over a rectangular notch is given by

$$Q = \frac{2}{3} B (2g H^{3/2})^{1/2}$$

and is 0.14m³/s when the water level is 23cm above the sill and if the coefficient of discharge is 0.6, calculate the width of notch required?

- [f] Bernoulli's theorem
- i. How is Bernoulli's theorem applied to pipeline problems between points for which the total energy is known?
- ii. Water from a large reservoir is discharged to atmosphere through a 100 mm diameter pipe 450m long. The entry from the reservoir to the pipe is sharp and the outlet is 12m below the surface level in the reservoir as presented in Figure 2 below. Taking $f = 0.01$ in Darcy formula, calculate the discharge.

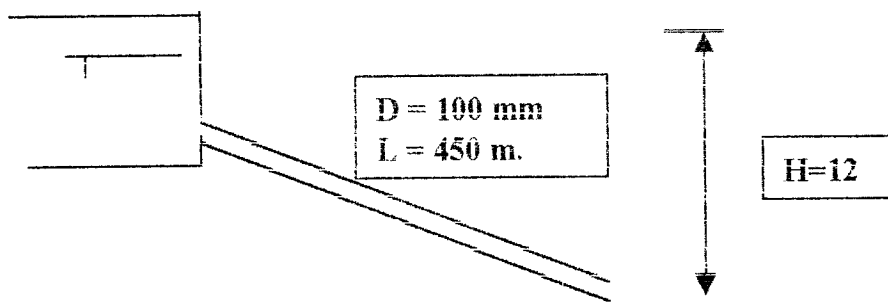

Figure 2. Water Reservoir

Prepare a total energy profile or diagram for the problem above(ii)

QUESTION FOUR (4)

Describe the types of droughts and methods used to estimate them?

What is a wetted perimeter and how does it relate to the hydraulic mean depth?

What criterion is used to classify pumps used in irrigation schemes?

What is the difference between a jet of water striking a ^{stationary} flat plate normally and that striking ~~stationary~~ a flat plate at angle (θ) to the ^{normal} normal?

What are the advantages of ground water as a storage medium.

QUESTION FIVE (5)

What are the three conditions, which a solid body can be in equilibrium?

Given that Chezy formula is $V = C (mi)^{1/2}$ and that a rectangular open channel has width B of 4.0m and slope of 1 vertical to 800 in horizontal

- Find the mean velocity of flow?
- Find the discharge Q when the depth D of water 1.2 meters, if C in the Chezy formula is 49 in units?

What are the likely problems you can encounter by pumping from two boreholes from one aquifer?

Precipitation supplies the water required for agriculture. In case of sprinkling irrigation or surface one uses precipitation fallen else where or another time.

- What is a return period?
- What is rainfall intensity?
- What is rainfall duration curve? Given the following from Table 1, estimate the discharge capacity and rainfall duration in case of a 30 mm storage?

Table 1. Rainfall data

Days	05	1	2	3	4
Rainfall mm	25	35	47	57	63

i. Prepare a total energy profile or diagram for the problem above(ii)

QUESTION FOUR (4)

- Describe the types of droughts and methods used to estimate them?
- What is a wetted perimeter and how does it relate to the hydraulic mean depth?
- What criterion is used to classify pumps used in irrigation schemes?
- What is the difference between a jet of water striking a ^{stationary} flat plate normally and that striking ~~stationary~~ a flat plate at angle (θ) to the ^{stationary} normal?
- What are the advantages of ground water as a storage medium.

QUESTION FIVE (5)

What are the three conditions, which a solid body can be in equilibrium?

Given that Chezy formula is $V = C (mi)^{1/2}$ and that a rectangular open channel has width B of 4.0m and slope of 1 vertical to 800 in horizontal

- Find the mean velocity of flow?
- Find the discharge Q when the depth D of water 1.2 meters, if C in the Chezy formula is 49 in units?

What are the likely problems you can encounter by pumping from two boreholes from one aquifer?

Precipitation supplies the water required for agriculture. In case of sprinkling irrigation or surface one uses precipitation fallen else where or another time.

- What is a return period?
- What is rainfall intensity?
- What is rainfall duration curve? Given the following from Table 1, estimate the discharge capacity and rainfall duration in case of a 30 mm storage?

Table 1. Rainfall data

Days	05	1	2	3	4
Rainfall mm	25	35	47	57	63

END OF EXAMINATION

THE UNIVERSITY OF ZAMBIA
SOIL SCIENCE DEPARTMENT
APRIL, 2002

AGS 511 SOIL CHEMISTRY

TIME: 3 HOURS

MARKS: 100

INSTRUCTION: ANSWER ALL QUESTIONS AND WRITE LEGIBLY

1. For each of the following soil pHs, give your best estimate of the chemical conditions that give that pH and tell how you would confirm your opinion by laboratory study.
 - a. pH = 9.8
 - b. pH = 8.3
 - c. pH = 6.8

(15 marks)

2. Calculate the activity coefficient for Ca^{2+} in a solution containing $7.3 \times 10^{-3} \text{ M KCl}$ and $2 \times 10^{-3} \text{ M CaCl}_2$ using the following
 - a). The Debye - Huckel limited equation
 - b) The D-H extended equation where the effective diameter of all ions is averaged at 3, that is $B_d = 1$.

(10 marks)

3. Use an example of one of the methods currently in use in soil laboratories to discuss how the concept of complex or ion - pair formation may be applied to determine concentrations of nutrients in the soil.

(10 marks)

- 4a. Explain the three double layer models (Helmholtz, Gouy - Chapman and Stern), making use of diagrams as needed.

- 4b. What is the significance of these theories when consideration is given to
 - i) Plant mineral nutrition.
 - ii) Reclamation of sodic soil.

(10 marks)

5. GIVEN

CALCULATE

- | | |
|---|--------------------|
| a) pH = 5.7 | (H ⁺) |
| b) (H ⁺) = 1.8 X 10 ⁻⁶ M | pH |
| c) (Al ³⁺) = 1.3 X 10 ⁻⁶ M | pAl |
| d) pH = 0 | (OH ⁻) |
| e) pK = 39.3 | K |

(10 marks)

6a. What normally happens to soil pH when flooded soils are drained?

Explain the pe vs pH relationships.

(10 marks)

6b In the case of acid sulphate soils the observation is different. Why?. (5 marks)

7. The President of the Republic of Zambia has just challenged agricultural Scientists to increase national food production potentials. As a Soil Scientist, what two challenges and opportunities in soil chemistry do you propose to tackle in each of the following areas.

- Northern Zambia
- Southern Zambia

Explain in detail from a chemistry background, giving possible solutions and the rationale behind such.

(20 marks)

End Of Examination

THE UNIVERSITY OF ZAMBIA

UNIVERSITY FIRST SEMESTER EXAMINATION

APRIL, 2002.

AGS 531: LAND EVALUATION AND IMPROVEMENT

TIME: 3 HOURS

MARKS: 80

ANSWER: ALL QUESTIONS AND WRITE LEGIBLY

1. After a soil survey the following land capability classes were determined. Interpret each one of them:

(a) C1 (b) S4t (c) Gw (d) C2de (e) S3tf

(10 marks)
2. Land use planning may be regarded as a three-phase process. Using suitable examples and illustrations, explain these phases, clearly indicating what may be involved in each one.

(10 marks)
3. a) From a land evaluation point of view what would be wrong with a simple statement such as "This is a good land?"

(5 marks)

b) Distinguish between land use planning and land evaluation.

(5 marks)
4. a) Land resource surveys may either be general or special - purpose. Explain

(5 marks)

b) Discuss the two main approaches that may be used in land evaluation

(5 marks)
5. Using suitable examples, explain the following terms in detail:
a) Land unit
b) Land use system.
c) Farming system
d) Compound land utilisation type

(10 marks)
6. Discuss the main land characteristics that define Zambia's agro-ecological zones.

(10 marks)
7. Although qualitative and parametric land evaluation methods are quite different, their operation involves some equivalent procedures. Illustrate the equivalency in operation between these two methods.

(10 marks)

8. A farmer has to make a choice to grow 2 out of the available three crops maize, sunflower and soyabeans on his 5 ha plot. The plot is a uniform land unit whose characteristics are represented by information in Profile No. 1 below. Reference crop yields, projected crop producer and fertiliser prices are given in Tables 1-3 below. Using a simple Storie Index, draw a crop priority list for this farmer, assuming this decision is purely based on economic returns (10 marks)

Table 1. Crop reference yields and projected producer prices.

<u>Crop</u>	<u>Reference Yields (Kg/ha)</u>	<u>Prod Price (Kwacha/ton)</u>
Maize	5,000	640,000.00
Soybeans	1,600	1,280,000.00
Sunflower	1,500	960,000.00

Table 2. Fertilizer rates

<u>Crop</u>	<u>Basal dressing/ha</u>	<u>Top dressing/ha.</u>
Maize	200kg D compound	200kg Urea
Soya bean	150kg D compound	Nil
Sunflower	200kg C compound	200 kg AN

Table 3. Fertiliser prices

D compound	K90,000/ 50kg bag
C compound	K95,000/ 50kg bag
Urea	K85,000 50kg bag
AN	K70,000/ 50 bag.

End of Examinations

THE UNIVERSITY OF ZAMBIA
UNIVERSITY FIRST SEMESTER EXAMINATIONS.

APRIL 2002

**AGS 551: PLANNING AND DEVELOPMENT OF IRRIGATION AND
DRAINAGE SYSTEMS.**

TIME: 3 HOURS

**INSTRUCTIONS: ANSWER ALL QUESTIONS
ALL QUESTIONS CARRY EQUAL MARKS. CALCULATORS, GRAPH PAPERS AND
WORK SHEETS ARE ALLOWED.**

QUESTION ONE (1)

A designer of a surface irrigation system MUST know the cumulative intake characteristics of the soil, must select a Manning roughness coefficient (n) appropriate for the crop to be irrigated and select the net application depth to be used as a basis for design.

(a) Explain the following concepts related to surface irrigation design.

- i. Opportunity time
- ii. Advance time
- iii. In flow time

A farmer in Chanyanya, Kafue district of Lusaka province in Zambia has a sprinklers irrigation system installed on his farm with spacing between laterals of 24 metres and spacing between sprinklers of 18 metres. The irrigation system has an application efficiency of 70%. Field water holding capacity has moisture contents of

1. $500\text{cm}^3/100\text{cm}^3$ at field capacity (FC)
2. $20\text{ cm}^3/100\text{ cm}^3$ at wilting point (WP)

He is growing and irrigating maize with root depth of 1.0 meter and a has a consumptive use (ET maize) of 8 mm/day. The safe depletion for the crop is 40% of available water. An infiltration experiment yielded the following results.

- i. Calculate the amount of depletion allowed in mm?
- ii. Determine irrigation interval in days?
- iii. Determine depth of each irrigation in mm?

Table 1. Results of Infiltration Test

Time (Min)	Height of water inner ring (cm)
0	0.0
2	2.0
4	3.50
6	3.70
8	4.80
10	4.89
12	4.97
14	5.05
16	5.13

- iv. Calculate the area covered by each sprinkler?
 - v. Determine water flow rate through each sprinkler (l/s) using the soil infiltration rate value?
- c) List the items/steps required in design of a sprinkler irrigation system.
 - d) What are the canal design problems.
 - e) Define:
 - i. Command in surface irrigation
 - ii. Water duty

QUESTIONS TWO (2)

- a) What are the basic considerations in understanding the cause of and mechanism of poor drainage?
- b) List five (5) benefits of drainage systems and three (3) types of drainage systems?
- c) A drainage well is being pumped at a rate of 1500m³ /day, it has a radius of influence of 500 meters. If the soil has a saturated depth of 60 metres and conductivity of 20m/day. What will be the draw down at a distance of 40 metres from the well given that

$$\Delta h_r = Q / (2\pi KD) * \ln r_e / r$$

- d) What are the disadvantages of covered or subsurface drains?
- e) Ground water flow in drainage systems?

QUESTION THREE (3)

- Show by a diagrammatic flow chart the process (steps) of planning an irrigation development programme?
- Discuss the factors on which actual evapotranspiration from a crop compared with potential evapotranspiration depends?
- Explain the main soil characteristic properties important in irrigation?
- Why is the knowledge of the movement of water into the soil important and how can it be estimated empirically?
- What are the salt inputs and outputs considerations in a salt balance equation.

QUESTIONS FOUR (4)

- What are the common drainage structures?
- What three of sprinklers systems exist?
- What are the advantages of trickle irrigation systems.
- What are the main components of a trickle sprinkler irrigation system.

QUESTION FIVE (5)

- Prepare a layout of a center pivot irrigation system and indicate the main features
- Determine the size of sprinklers, laterals, pump and power unit for the sprinkler system layout shown below with the following conditions.

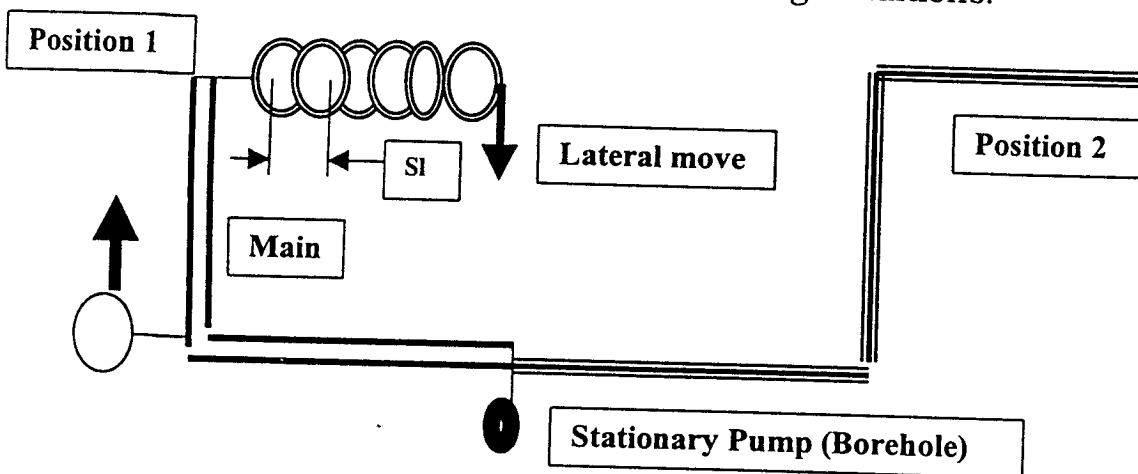

Figure 1. Sprinkler Irrigation Layout

$H_a = 30\text{m}$, $H_j = 0.5\text{m}$, $H_e = 2.2\text{m}$, $H_s = 3.5\text{m}$
 $I = 1.25\text{cm/hr}$, maximum length of main = 60m
 $SI = 15\text{m}$, $S_m = 20\text{m}$ and allowance variation in pressure in the lateral is 20%

END OF EXAMINATION

THE UNIVERSITY OF ZAMBIA
SCHOOL OF ENGINEERING
AGRICULTURAL ENGINEERING
FIRST SEMESTER EXAMINATIONS APRIL 2002
EA 311 (FARM POWER AND MACHINERY)

INSTRUCTIONS

TIME ALLOWED: **THREE HOURS**

ATTEMPT: **FIVE QUESTIONS ONLY; TWO FROM SECTION A, ONE FROM SECTION B AND THE LAST TWO FROM SECTION C.**

ANSWER SECTION A, SECTION B AND SECTION C IN SEPARATE ANSWER BOOKLETS.

ALL QUESTIONS CARRY EQUAL MARKS, (20 MARKS EACH).

THIS QUESTION PAPER COMPRISES EIGHT QUESTIONS.

SECTION A: ANSWER TWO (2) QUESTION FROM THIS SECTION.

Question 1

- d) With reference to **Figure Q1** list the parts A to G. [7 marks]
- e) What type of engine is this? Give reasons for your answer [3 marks]
- f) Describe how ignition is achieved in this engine. [5 marks]
- g) Make a sketch of the gasoline fuel system and label the 3 basic component of this system and describe the primary function of these parts. [5 marks]

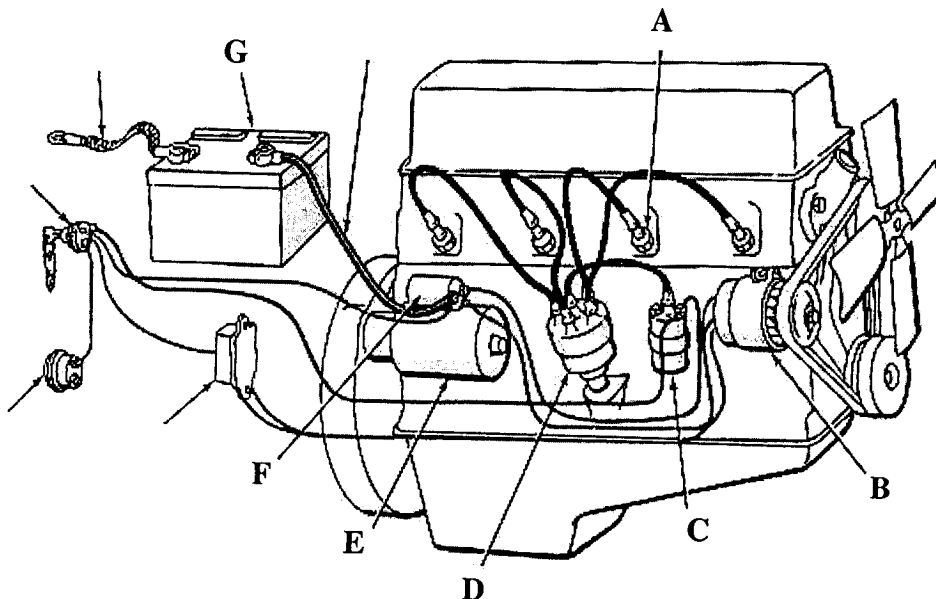

Figure Q1

Question 2

- a) List the functions of a governor. [2 marks]
- b) What does a mechanical governor control in:
 - i) a petrol engine? [1 mark]
 - ii) a diesel engine? [2 marks]
- c) Describe the operations of the mechanism in injector pumps used to meter the amount of fuel delivered to injectors on a diesel engine [8 marks]
- d) Describe the oil mist lubrication system. [4 marks]
- e) Briefly explain why an electric powered tractor would be preferred to a diesel-powered tractor for use in a green house. [3 marks]

Question 3

- a) A four cylinder four stroke cycle engine with a firing order 1-3-4-2 is given in **Table Q3a**. Make a similar table for a six cylinder two stroke cycle engine with a firing order 1-4-2-6-3-5 by first determining the angle between any two power strokes that immediately follow each other. Use **Table Q3b** on the last page of this examination paper to answer this question. [10 marks]
- b) For this engine what is the ratio of the crankshaft gear to the camshaft gear. [2 marks]
- c) True or False? "For an engine operated at variable speeds a lighter flywheel is needed." [2 marks]
- d) Name **three** functions of a lubrication system. [6 marks]

Table Q3a

Crank travel	Cylinder number			
	1	2	3	4
180°	Power			
360°			Power	
540°				Power
720°		Power		

SECTION B: ANSWER ONE (1) QUESTION FROM THIS SECTION.

Question 4

- a) What is the purpose of a harness and what factors influence its choice? [5 marks]
- b) List three species of animals most widely used for animal draught power and state at least three advantages and three disadvantages of each specie. [10 marks]
- c) State five characteristics of good animal housing? [5 marks]

Question 5

- a) Define both dynamic and static work and give an example of each. [4 marks]
- b) Why should lactic acid not be allowed to accumulate in the body and how is it removed? [3 marks]
- c) What three functions does the food a human being eat used for? [3 marks]
- d) Explain the concept and the necessity for a human being to rest when carrying out certain jobs [10 marks]

SECTION C: ANSWER TWO (2) QUESTIONS FROM THIS SECTION.

Question 6

- a) State two differences between a disc plough and a disc harrow? [5 marks]
- b) With the help of a sketch of a tandem disc harrow, briefly explain its action and effects on the soil. [5 marks]
- c) For each of the following tillage objectives on fields located within Lusaka Province, state one implement that would best accomplish each task:
- i) Clean tillage around mid January in a field that has a lot of crop residue and weeds.
 - ii) Conservation tillage in the month of May of a field that is prone to wind erosion and has developed a medium strength hard pan due to repeated use of a disk plough.
 - iii) Seedbed preparation of a field in one pass following harvesting of the previous crop.
 - iv) Covering barley seeds after broadcasting operation in early December.
 - v) Primary tillage of a field with extremely dry soils and outcrops of stones and roots just before the on-set of rains in October. [5 marks]
- d) State two adjustments that have to be carried out on almost all soil engaging implements to ensure that the implement works the soil to a uniform depth. [5 marks]

Question 7

- a) State the key difference between the procedure of workshop calibration and that of field calibration of a seed drill. [4 marks]
- b) Outline two sources of discrepancy in the results of workshop calibration and those of field calibration of a seed drill. [4 marks]
- c) State the functions performed by the following components of a tractor mounted sprayer
- i) Nozzle
 - ii) Pump
 - iii) Pressure relief valve
 - iv) Filter
- [4 marks]
- d) A farmer would like to apply 121 l/ha of a certain pesticide using a tractor-mounted sprayer. Only one set of nozzles is available and each nozzle has a capacity of 2.27 litres/minute when operating at a pressure of 4 bars. If the sprayer has 40 nozzles spaced 75 cm apart, what tractor speed is required to apply the correct amount of the pesticide? [4 marks]
- e) If the operating speed of the tractor had to be limited to 10 km/hr due to poor field conditions, calculate the pressure at which the sprayer should be operated in order to maintain the pesticide application rate of 121 l/ha. [4 marks]

Question 8

- a) Briefly discuss crop rotation as a mechanism for weed control. [5 marks]
- b) Describe the harvesting process of a crop of wheat using a combine harvester, clearly outlining the tasks involved in their correct order of execution and state the components that perform each task indicated. [10 marks]
- c) List the possible causes of the following situations during combine harvesting of a crop:
- i) excessive shatter of a crop
 - ii) excessive amount of unthreshed heads
 - iii) broken kernels of grain
 - iv) excessive amount of chaff in the grain tank.
 - v) excessive clean seed loss.
- [5 marks]

