

UNIVERSITY OF ZAMBIA
SCHOOL OF MINES
DEPARTMENT OF GEOLOGY
POST GRADUATE
2016-2017 ACADEMIC YEAR

- GGY 5202 MINERAL ECONOMICS & MANAGEMENT
- GGY 5139 ENGINEERING GEOLOGY AND ROCK MECHANICS
- GGY 5149 EXPLORATION GEOPHYSICS
- GGY 5159 ECONOMIC GEOLOGY OF METALLIFEROUS MINERAL
DEPOSITS
- GGY 5179 ECONOMIC GEOLOGY OF ENERGY AND INDUSTRIAL
MINERALS DEPOSITS
- GGY 5189 HYDROGEOLOGY
- MET 5239 IRON AND STEEL MAKING
- MET 5259 SPECIAL TOPICS IN EXTRACTIVE METALLURGY
- MET 5329 MATERIALS PERFORMANCE
- MET 5349 FOUNDRY TECHNOLOGY
- MET 5469 PROCESS DESIGN
- MIN 5019 GEOTECHNICAL ENGINEERING
- MIN 5029 COAL MINING METHODS
- MIN 5045 MINE MANAGEMENT

MIN 5049 APPLICATION OF COMPUTERS IN MINING

MIN 5065 SAFETY HEALTH AND ENVIRONMENT

MIN 5069 SAFETYHEALTH AND ENVIRONMENT

MIN 5079 ROCK MECHANICS II

MIN 5089 MINE PLANNING AND DESIGN

MIN 5099 MINERAL ECONOMICS & MANAGEMENT

UNIVERSITY OF ZAMBIA
UNIVERSITY EXAMINATION – SEPTEMBER 2016

GGY 5202/MIN 5099 – MINERAL ECONOMICS & MANAGEMENT

INSTRUCTIONS: Answer **Question One** and any other **three**
DCF Tables are attached at the end

TOTAL MARK: 100

TIME: 3 HOURS

CLOSED BOOK

QUESTION ONE

A mining company conducts internal exploration assignments in the brownfield arenas of its mineral tenements. A tailings dump with 15,360,000 tonnes of ore material was delineated and further earmarked for processing using a conventional metallurgical processing plant. The average grade for the material on the dump is 0.55% Cu and the expected overall recovery is 95%. The sales price for the extracted ore material is \$500/tonne while overall operational costs are estimated at 50% of the annual revenues. The capital cost for the plant was projected at \$12,500,000 with an agreed estimate of 10% for the cost of capital. Monthly extraction rate for the tailings dump is 320,000 tonnes.

By ignoring taxation and depreciation, evaluate this project by making estimations of the:

- (i) Net Present Value (NPV) [5]
- (ii) Benefit-Cost ratio [3]
- (iii) Undiscounted payback period (in exact years with months) [3]
- (iv) Correct Internal Rate of Return (IRR) if the disputed IRR is occurring at 24% [4]
- (v) New NPV and commenting on the project's viability after accounting for taxation and depreciation. This follows an imposition of the fiscal regime by the government providing for 30% corporate tax, 6% gross mineral royalty tax and a depreciation charge based on Straight Line Method (SLM) with a salvage value of \$5,000,000. [10]

QUESTION TWO

- (a) In terms of cost, volume and profit (CVP) analyses, make clear the classification of costs based on *changes in activities*. [6]
- (b) A mine runs a poly-metallic mineral deposit project which produces three commodities in a shared facility. The following information on cost per unit and tonnages is given:

	Copper	Cobalt	Nickel
Tonnage	6,000	5,000	4,000
Selling price (US\$)	150	200	250
Variable Cost (US\$)	80	100	150
Fixed Cost (US\$)	50	120	70

You are required to compute the:

- (i) Total fixed costs [3]
- (ii) Total contribution [3]
- (iii) Weighted average contribution margin (WACM) [3]
- (iv) Break -even point (in tonnes) using the WACM [3]
- (v) Profitability for each product by using the P/V ratio and stating which product is likely to give the highest contribution. [7]

QUESTION THREE

A mineral commodity has the following original functions:

$$Q_d = 40 - 6P$$

$$Q_s = 4 + 6P$$

Q_d and Q_s are respectively demand and supply quantities in tonnes and P is the price in US\$/tonne.

- (i) Determine the market *equilibrium conditions* [4]
- (ii) If demand increases by 65% given the supply curve, determine the *new demand* function with the corresponding equilibrium conditions [4]
- (iii) Illustrate your answers following this change in the demand function [4]
- (iv) Produce the *Total Revenue (TR)* function using the original demand expression and use it to calculate the quantity needed to maximize revenue. [4]

- (v) For the original demand function and using the commodity values ranging from 5 to 30 tonnes with a 5 tonne spacing, derive the Total Revenue (TR) *schedule*. [9]

QUESTION FOUR

- (a) Clarify the features associated with a *monopoly* market structure [5]
- (b) A mining firm operating in a monopoly market has a total cost function given by $TC = 1.5Q^2$. This firm produces a mineral product with a demand equation given as $20 - P = 3Q$ where Q is the quantity in tonnes and P is the price in US\$.
You are required, for this firm, to determine the:
- (i) Profit maximizing *output* [4]
 - (ii) *Profit* realized at the profit maximizing quantity [4]
 - (iii) Average Revenue (AR) function [4]
 - (iv) Output that can maximize sales revenue [4]
 - (v) Total Revenues at the revenue maximizing and profit maximizing outputs [4]

QUESTION FIVE

- (a) Explain the functions of management associated with general *planning process* [4]
- (b) Mine management has two mutually exclusive projects A and B being evaluated for further investment. The variance and expected return estimates for the two projects are given as:

	Project A	Project B
Expected Return	0.12	0.16
Variance	0.22	0.50
Volatility Measure (β)	1.80	1.40

Given that the risk-free rate is 9% and the expected market return is 14%,

- (i) Calculate the returns on individual projects using the security market line (SML) concept [4]
- (ii) Estimate the Coefficient of Variations (CVs) for the projects [4]

(iii) Describe how investment decisions would be for the *risk takers* and *risk averse* project managers based on your calculations and estimations. [4]

(c) Mine management plans to acquire an asset to improve operations at a cost of \$360,000. This asset is planned to be depreciated over a period of 5 years with a salvage value estimated at \$60,000. Prepare the schedules for the *annual depreciation* charges for this asset with the associated *book values* under each of the following methods of depreciation:

(i) Straight Line Method (SLM) [4]

(ii) Sum - of - Years Digit (SYD) method [5]

QUESTION SIX

(a) Describe the distinction between production in the *short-run* and *long-run* perspectives with two examples of inputs used in each situation. [6]

(b) A polynomial function for a firm's production function is given as:

$Q = 10L - 0.5L^2 + 25K - K^2$. The unit labour (L) cost is \$1,000 while capital (K) is set at \$1,500 per unit. Q is production in tonnes. If the labour input is 2 units, use the least-cost combination notion to calculate;

(i) The resulting output Q [3]

(ii) The firm's total input cost [3]

(c) The following information about production is given with one factor input held constant.

Number of Input A	1	2	3	4	5	6
Marginal Product of A (MP_A)	3	5	4	2	0	-2

(i) For the given information and showing formulae, calculate for each level of input A, the;

• Total Physical Product of A (TP_A) [3]

• Average Physical Product of A (AP_A) [3]

- (ii) Plot the graph of the MP_A and AP_A and give an explanation of the operations of *diminishing returns* of input A. [7]

END OF EXAMINATION

Information to use:

$$IRR = A + [(P/P+N) \times (B-A)]$$

Where: A is the lower rate of return with a positive NPV

B is the higher rate of return with a negative NPV

P is the positive value NPV

N is the negative value NPV

Table A-1
Present Value of \$1: $PVIF_{k,n} = 1/(1+k)^n$

Period	1%	2%	3%	4%	5%	6%	7%	8%	9%	10%	12%	14%	15%	16%	18%	20%	24%	28%	32%	36%
1	.9901	.9804	.9709	.9615	.9524	.9434	.9346	.9259	.9174	.9091	.8929	.8772	.8696	.8621	.8475	.8333	.8065	.7813	.7576	.7353
2	.9803	.9612	.9426	.9246	.9070	.8900	.8734	.8573	.8417	.8264	.7972	.7695	.7461	.7232	.7012	.6804	.6407	.6104	.5799	.5407
3	.9706	.9423	.9151	.8890	.8638	.8396	.8163	.7938	.7722	.7513	.7118	.6750	.6429	.6147	.5896	.5782	.5245	.4768	.4348	.3975
4	.9610	.9238	.8885	.8548	.8227	.7921	.7629	.7350	.7084	.6830	.6355	.5914	.5518	.5158	.4823	.4230	.3725	.3294	.2923	.2628
5	.9515	.9057	.8626	.8219	.7835	.7473	.7130	.6806	.6499	.6209	.5674	.5249	.4872	.4531	.4019	.3411	.2910	.2495	.2149	.1880
6	.9420	.8880	.8375	.7903	.7462	.7050	.6663	.6302	.5963	.5645	.5066	.4656	.4283	.3944	.3539	.3049	.2551	.2274	.1890	.1580
7	.9327	.8706	.8131	.7599	.7107	.6651	.6227	.5835	.5470	.5132	.4523	.4136	.3759	.3404	.3080	.2781	.2278	.1976	.1432	.1162
8	.9235	.8535	.7894	.7307	.6768	.6274	.5820	.5403	.5019	.4665	.4039	.3666	.3297	.2944	.2606	.2286	.1779	.1443	.1085	.0854
9	.9143	.8368	.7664	.7026	.6446	.5919	.5439	.5002	.4604	.4241	.3606	.3235	.2863	.2509	.2174	.1843	.1339	.1084	.0822	.0628
10	.9053	.8203	.7441	.6756	.6139	.5584	.5093	.4632	.4224	.3855	.3220	.2857	.2472	.2114	.1771	.1443	.1184	.0847	.0623	.0462
11	.8963	.8043	.7224	.6496	.5847	.5268	.4751	.4289	.3875	.3505	.2875	.2366	.2149	.1954	.1619	.1346	.0938	.0662	.0472	.0340
12	.8874	.7885	.7014	.6246	.5568	.4970	.4440	.3971	.3555	.3186	.2567	.2076	.1869	.1685	.1372	.1122	.0757	.0517	.0357	.0250
13	.8787	.7730	.6810	.6006	.5303	.4688	.4150	.3678	.3262	.2897	.2292	.1821	.1625	.1452	.1163	.0935	.0610	.0404	.0271	.0184
14	.8700	.7579	.6611	.5775	.5051	.4423	.3878	.3405	.2992	.2633	.2046	.1597	.1413	.1252	.0985	.0779	.0492	.0316	.0205	.0135
15	.8613	.7430	.6419	.5553	.4810	.4173	.3624	.3152	.2745	.2394	.1827	.1401	.1229	.1079	.0855	.0649	.0397	.0247	.0155	.0099
16	.8528	.7284	.6232	.5339	.4581	.3936	.3387	.2919	.2519	.2176	.1631	.1229	.1069	.0930	.0708	.0541	.0320	.0193	.0118	.0073
17	.8444	.7142	.6050	.5134	.4363	.3714	.3166	.2703	.2311	.1978	.1456	.1078	.0929	.0802	.0600	.0451	.0258	.0150	.0089	.0054
18	.8360	.7002	.5874	.4936	.4155	.3503	.2959	.2502	.2120	.1799	.1300	.0946	.0808	.0691	.0508	.0376	.0208	.0118	.0068	.0039
19	.8277	.6864	.5703	.4746	.3957	.3305	.2765	.2317	.1945	.1635	.1161	.0829	.0703	.0596	.0431	.0313	.0168	.0092	.0051	.0029
20	.8195	.6730	.5537	.4564	.3769	.3118	.2584	.2145	.1784	.1486	.1037	.0728	.0611	.0514	.0365	.0261	.0135	.0072	.0039	.0021
21	.8114	.6598	.5375	.4388	.3589	.2942	.2415	.1987	.1637	.1351	.0826	.0638	.0531	.0443	.0309	.0217	.0109	.0056	.0029	.0016
22	.8034	.6468	.5219	.4220	.3418	.2775	.2257	.1839	.1502	.1228	.0626	.0560	.0462	.0382	.0262	.0181	.0088	.0044	.0022	.0012
23	.7954	.6342	.5067	.4057	.3256	.2618	.2109	.1703	.1378	.1117	.0738	.0491	.0402	.0329	.0222	.0151	.0071	.0034	.0017	.0008
24	.7876	.6217	.4919	.3901	.3101	.2470	.1971	.1577	.1264	.1015	.0659	.0431	.0349	.0284	.0188	.0126	.0057	.0027	.0013	.0006
25	.7798	.6095	.4776	.3751	.2953	.2330	.1842	.1460	.1160	.0923	.0588	.0378	.0304	.0245	.0160	.0105	.0046	.0021	.0010	.0005
26	.7720	.5976	.4637	.3607	.2812	.2198	.1722	.1352	.1064	.0839	.0525	.0331	.0264	.0211	.0135	.0087	.0037	.0016	.0007	.0003
27	.7644	.5889	.4502	.3468	.2678	.2074	.1609	.1232	.0976	.0763	.0469	.0291	.0230	.0182	.0115	.0073	.0030	.0013	.0006	.0002
28	.7568	.5744	.4371	.3335	.2551	.1956	.1504	.1129	.0885	.0693	.0419	.0255	.0200	.0157	.0097	.0061	.0024	.0010	.0004	.0002
29	.7493	.5631	.4243	.3207	.2429	.1846	.1406	.1073	.0822	.0630	.0374	.0224	.0174	.0135	.0082	.0051	.0020	.0008	.0003	.0001
30	.7419	.5521	.4120	.3083	.2314	.1741	.1314	.0994	.0754	.0573	.0334	.0196	.0151	.0116	.0070	.0042	.0016	.0006	.0002	.0001
35	.7059	.5000	.3554	.2534	.1813	.1301	.0937	.0676	.0490	.0356	.0189	.0102	.0075	.0055	.0030	.0017	.0005	.0002	.0001	.
40	.6717	.4529	.3066	.2083	.1420	.0972	.0688	.0460	.0318	.0221	.0107	.0053	.0037	.0026	.0013	.0007	.0002	.0001	.	.
45	.6391	.4102	.2644	.1712	.1113	.0727	.0476	.0313	.0207	.0137	.0061	.0027	.0019	.0013	.0006	.0003	.0001	.	.	.
50	.6080	.3715	.2281	.1407	.0872	.0543	.0339	.0213	.0134	.0085	.0035	.0014	.0009	.0006	.0003	.0001
55	.5785	.3365	.1968	.1157	.0683	.0406	.0242	.0145	.0087	.0053	.0020	.0007	.0005	.0003	.0001

The factor is zero to four decimal places.
Copyright © 1984 The Dryden Press A Division of CBS College Publishing

Table A-2
Present Value of an Annuity of \$1 per Period
for n Periods:

$$PV/A_n = \sum_{k=1}^n \frac{1}{(1+k)^k} = \frac{1 - \frac{1}{(1+k)^n}}{k}$$

Number of Periods	1%	2%	3%	4%	5%	6%	7%	8%	9%	10%	12%	14%	15%	16%	18%	20%	24%	28%	32%
1	0.9901	0.9804	0.9709	0.9615	0.9524	0.9434	0.9346	0.9259	0.9174	0.9091	0.8929	0.8772	0.8696	0.8621	0.8475	0.8333	0.8095	0.7813	0.7576
2	1.9704	1.9416	1.9135	1.8861	1.8594	1.8334	1.8080	1.7833	1.7591	1.7355	1.6991	1.6627	1.6296	1.5987	1.5697	1.5423	1.4985	1.4584	1.4216
3	2.9410	2.8839	2.8286	2.7751	2.7232	2.6730	2.6243	2.5771	2.5313	2.4869	2.4018	2.3216	2.2832	2.2469	2.2123	2.1697	2.0985	2.0316	1.9688
4	3.9020	3.8077	3.7171	3.6299	3.5460	3.4651	3.3872	3.3121	3.2397	3.1699	3.0373	2.9137	2.8550	2.7982	2.7430	2.6801	2.5785	2.4816	2.3892
5	4.8534	4.7135	4.5797	4.4518	4.3295	4.2124	4.1002	3.9927	3.8897	3.7908	3.6048	3.4331	3.3522	3.2743	3.1272	2.9906	2.8485	2.7116	2.5792
6	5.7955	5.6014	5.4172	5.2421	5.0757	4.9173	4.7665	4.6229	4.4859	4.3553	4.1114	3.8887	3.7845	3.6847	3.4976	3.3256	3.2005	3.0834	2.9652
7	6.7282	6.4720	6.2303	6.0021	5.7864	5.5824	5.3893	5.2064	5.0330	4.8684	4.5638	4.2888	4.1604	4.0386	3.8115	3.6046	3.4243	3.2570	3.0933
8	7.6517	7.3255	7.0197	6.7327	6.4632	6.2098	5.9713	5.7466	5.5348	5.3349	4.9676	4.6389	4.4873	4.3436	4.0776	3.8372	3.6212	3.4212	3.2360
9	8.5680	8.1622	7.7851	7.4353	7.1078	6.8017	6.5152	6.2469	5.9952	5.7590	5.3282	4.9464	4.7716	4.6065	4.3000	4.0310	3.7855	3.5612	3.3576
10	9.4713	8.9826	8.5302	8.1109	7.7217	7.3601	7.0236	6.7101	6.4177	6.1466	5.6502	5.2161	5.0188	4.8332	4.4941	4.1925	3.8919	3.6899	3.5004
11	10.3676	9.7868	9.2526	8.7605	8.3064	7.8869	7.4987	7.1390	6.8052	6.4851	5.9377	5.4527	5.2337	5.0286	4.6560	4.3271	3.9757	3.7526	3.5476
12	11.2551	10.5753	9.9540	9.3851	8.8633	8.3838	7.9427	7.5361	7.1607	6.8137	6.1944	5.6693	5.4206	5.1971	4.7832	4.4392	4.0514	3.8088	3.5833
13	12.1337	11.3484	10.6350	9.9856	9.3936	8.8527	8.3577	7.9038	7.4869	7.1034	6.4235	5.8424	5.5831	5.3423	4.9095	4.5327	4.1124	3.8272	3.6043
14	13.0037	12.1082	11.2961	10.5831	9.8966	9.2950	8.7455	8.2442	7.8262	7.4407	6.7067	6.1622	5.8714	5.6011	5.0916	4.6755	4.2213	3.8834	3.6374
15	13.8651	12.8493	11.9379	11.1184	10.3797	9.7122	9.1079	8.5595	8.0607	7.6961	6.8109	6.1422	5.8474	5.5755	5.0396	4.5755	4.0813	3.7834	3.5074
16	14.7179	13.5777	12.5611	11.6523	10.8378	10.1059	9.4466	8.8514	8.3126	7.8237	6.7400	6.0216	5.6942	5.3885	4.8224	4.3271	3.8033	3.5026	3.0882
17	15.5623	14.2919	13.1661	12.1657	11.2741	10.4773	9.7632	9.1216	8.5436	8.0216	7.1196	6.3529	6.0072	5.7188	5.1223	4.5746	4.0231	3.7177	3.0971
18	16.3983	14.9920	13.7555	12.6593	11.6896	10.8276	10.0591	9.3719	8.7556	8.2014	7.2497	6.4674	6.1080	5.8178	5.2232	4.6322	4.0589	3.7482	3.1239
19	17.2280	15.6785	14.3238	13.1339	12.0853	11.1581	10.3386	9.6036	8.9501	8.3649	7.3658	6.5504	6.1982	5.8775	5.3162	4.6953	4.0957	3.7786	3.1490
20	18.0456	16.3514	14.8775	13.5903	12.4622	11.4699	10.5940	9.8181	9.1285	8.5136	7.4694	6.6231	6.2593	5.9288	5.3527	4.6996	4.1103	3.7958	3.1129
21	18.8570	17.0112	15.4150	14.0292	12.8212	11.7641	10.8355	10.0168	9.2822	8.6487	7.5620	6.6870	6.3125	5.9731	5.3837	4.6913	4.1212	3.7514	3.1158
22	19.6604	17.6580	15.9369	14.4511	13.1630	12.0416	11.0612	10.2007	9.4424	8.7715	7.6446	6.7429	6.3587	6.0113	5.4099	4.6994	4.1300	3.7558	3.1180
23	20.4558	18.2922	16.4436	14.8586	13.4886	12.3034	11.2722	10.4591	9.5802	8.8832	7.7184	6.7944	6.3988	6.0442	5.4321	4.7025	4.1371	3.7592	3.1197
24	21.2434	18.9139	16.9335	15.2470	13.7986	12.5504	11.4693	10.5288	9.7066	8.9947	7.7843	6.8351	6.4338	6.0726	5.4509	4.7371	4.1428	3.7619	3.1210
25	22.0232	19.5235	17.4131	15.6221	14.0939	12.7834	11.6536	10.6748	9.8226	9.1811	7.8431	6.8729	6.4641	6.0971	5.4689	4.7476	4.1474	3.7640	3.1220
26	22.7952	20.1210	17.8768	15.9828	14.3732	13.0032	11.8258	10.8100	9.9290	9.1609	7.8957	6.9051	6.4906	6.1182	5.4804	4.7563	4.1511	3.7656	3.1227
27	23.5596	20.7069	18.3270	16.3296	14.6430	13.2105	11.9867	10.9352	10.0266	9.2372	7.9446	6.9307	6.5135	6.1364	5.4919	4.7636	4.1542	3.7669	3.1233
28	24.3164	21.2813	18.7641	16.6631	14.8981	13.4062	12.1371	11.0511	10.1161	9.3066	7.9844	6.9607	6.5335	6.1520	5.5016	4.7697	4.1566	3.7679	3.1237
29	25.0658	21.8444	19.1885	16.9837	15.1411	13.5907	12.2777	11.1584	10.1985	9.3896	8.0218	6.9830	6.5509	6.1656	5.5098	4.7747	4.1585	3.7687	3.1240
30	25.8077	22.3965	19.6004	17.2920	15.3725	13.7648	12.4090	11.2578	10.2737	9.4269	8.0552	7.0027	6.5660	6.1772	5.5168	4.7789	4.1601	3.7693	3.1242
35	29.4086	24.9986	21.4872	18.6646	16.3742	14.4982	12.9477	11.6546	10.5688	9.6442	8.1755	7.0700	6.6166	6.2153	5.5396	4.7915	4.1644	3.7708	3.1248
40	32.8347	27.3555	23.1148	19.7928	17.1591	15.0463	13.3317	11.9591	10.7574	9.8678	8.2438	7.1050	6.6418	6.2335	5.5482	4.7966	4.1669	3.7712	3.1250
45	36.0945	29.4902	24.5187	20.7900	18.2518	15.4558	13.6055	12.1084	10.8812	10.0612	8.2945	7.1232	6.6543	6.2421	5.5523	4.7996	4.1684	3.7714	3.1250
50	39.1961	31.4226	25.7298	21.4822	18.2959	15.7619	13.8007	12.2335	10.9617	10.1418	8.3045	7.1327	6.6605	6.2463	5.5541	4.7995	4.1686	3.7714	3.1250
55	42.1472	33.1748	26.7744	22.1086	18.6335	15.9905	13.9399	12.3186	11.0140	10.1971	8.3170	7.1376	6.6636	6.2482	5.5549	4.7998	4.1686	3.7714	3.1250

col

THE UNIVERSITY OF ZAMBIA
UNIVERSITY EXAMINATIONS – SEPTEMBER 2016
GGY5139 – ENGINEERING GEOLOGY AND ROCK MECHANICS

TIME: 3 HOURS

ANSWER: ANYFOUR QUESTIONS. ALL QUESTIONS CARRY EQUAL MARKS.

- 1 The Dean of the School of Mines has requested MTN to construct a reception tower in the grounds east of the building to provide Wi-Fi services to students in the School. A group of 5th year geology students was contracted to conduct a geophysical survey on the site. The survey gave the following results:

Geophone distance (m)	10	15	20	25	30	35	40	45	50	55
Arrival times (ms)	3	4.5	6	7	7.8	8.5	9	10	10.6	11.5

Assuming that the layers are horizontal, and the second layer forms bedrock at the site, calculate the amount of excavation that would be needed to reach the competent rock layer.

- 2 A nine-metre deep borehole was drilled through the rock underlying a site for the construction of an MTN reception tower to assess its integrity. Core recoveries from a borehole drilled in this rock are laid out in a core box as shown below (lengths are in centimetres):

11.8	1.3	3.0	2.8	5.8	5.0	2.5	9.0	12.3	5.0	5.0	2.8	5.3
8.0	20.0	10.8	87.9	3.3	13.8	10.3	2.3	3.3	7.3	10.5	7.8	16.0
3.0	4.3	8.2	53.1	7.0	11.0	3.0	8.0	6.5	7.5	5.5	6.5	7.0
110	7.9	36.0	17.0	3.8	5.3	59.0	12.3	95.3	19.4	7.3	10.8	10.5

Discuss, with some justification, the integrity of this rock to support the foundation of the proposed structure.

- 3 A road embankment with a dip direction and dip of 130/30 is planned for construction in one of the hills to accommodate the Bottom Road in Siavonga District. Two major discontinuity sets were mapped crossing this hill with the following attitudes:

Discontinuity Set	Dip Direction (°)	Dip(°)
1	160	50
2	100	40

Discuss, whether or not, the slope would be stable if it were to be cut in this hill.

- 4 Black soils from the East Park Mall were excavated and the area backfilled with soil imported from a quarry in the Bauleni area. A sample with a mass of 1000 g of the imported soil was analysed at the Environmental Engineering Laboratory in the School of Engineering and gave the following results:

Grain size (mm)	50.0	35.5	20	14	10	6.3	3.35	1.18	0.6	0.15	0.063
Mass retained (g)	0	72.6	74.1	67.1	68.1	90.1	171.6	120.7	75.3	74.1	67.6

For this soil:

- i) Determine, on the basis of the British Standards Institution (BSI), as shown in the Table below, the percentage of each fraction contained in the soil.

Soil Fraction	Clay	Silt	Sand	Gravel	Cobble
Particle Size (mm)	< 0.002	0.002 – 0.06	0.06 – 2	2 – 60	> 60

- ii) Discuss, whether or not this soil was suitable for backfilling.

5 During site investigations for the East Park Shopping Mall, it was imperative to determine Atterberg Limits of the black soils underlying the site in order to characterize their water holding capacity. Fine soil fractions obtained from the site were used to determine the liquid- and plastic limits, and gave the following results:

i) Liquid limit

Test	1	2	3	4	5	6
Number of Blows	6	8	12	26	28	31
% Water Content	55.6	52.8	48.3	39.6	38.8	38

ii) Plastic limit

Test Number	Mass of Tin	Tin + Wet Soil (g)	Tin + Dry Soil (g)
1	25.34	32.17	31.01
2	24.83	30.48	29.51

For this soil, **determine** its plasticity index. How would you characterise its water-holding capacity, and why?

6 After cutting a slope at an angle of 60° for the construction of an embankment in a hill on the Bottom Road, it was discovered that a potential failure plane dipping at 45° day-lighted into the cut slope. Samples collected at three points on this plane were subjected to shear box testing in the lab and produced the following results:

Normal stress (kNm^{-2})	100	200	300	400
Shear stress (kNm^{-2})	98	139	180	222

If the potential failure plane was over-lain by a block weighing 500kN with a contact area of 200 m^2 , determine:

- Whether or not the slope would be stable, and why.
- In an event of instability, prescribe any possible method of stabilising it.

END OF EXAMINATION. GOOD LUCK

THE UNIVERSITY OF ZAMBIA
UNIVERSITY EXAMINATIONS – AUGUST/SEPTEMBER 2017
GGY5139 – ENGINEERING GEOLOGY AND ROCK MECHANICS

TIME: 3 HOURS

ANSWER: ALL QUESTIONS FROM SECTION A, AND ANY THREE QUESTIONS FROM SECTION B.
ALL QUESTIONS IN SECTION B CARRY EQUAL MARKS.

SECTION A: MULTIPLE CHOICE AND SHORT ANSWER QUESTIONS (25 Marks)

1. POROSITY is found by dividing: a) volume of solids by the volume of voids b) volume of voids by the volume of water c) the volume of voids by the total volume of the sample d) volume of voids by the volume of solids.
 2. In engineering practice, rock is divided into: a) igneous, sedimentary and metamorphic rocks b) intact rock and rock mass c) sediments and rocks d) none of these.
 3. A site location map must include scale, orientation, title, and: a) geologic units b) legend c) topographic contours d) dip and strike symbols.
 4. In a stress-strain test, rocks that exhibit a significant amount of plastic response before failure are said to be _____.
 5. With **increasing** depth below the Earth's surface: a) rocks get more dense b) rocks get less dense c) rock density first increases, then decreases again d) rock density first decreases, then increases again
 6. According to the Unified Soil Classification, a soil described as a GW is a _____.
 7. According to Darcy's Law: a) the velocity of flow in clay is higher than in sand. b) the higher the gradient, the lower the velocity. c) The water table is generally flatter in an area of high transmissivity d) spring flow is independent of the hydraulic characteristics of the aquifer.
 8. Prediction of swelling potential in soil is possible using which of the following? A) grain size b) Atterberg limits c) organic content of the soil d) colour.
 9. The capacity of a rock to transmit water is called _____.
 10. As seismic waves pass from a rock layer of a certain density to an adjacent rock layer with a different density, the following is true: a) the waves vanish at the interface between the two rock layers a) the waves pass across the boundary unchanged c) some of the waves get reflected d) both C and D.
 11. Sediment near the Earth's surface only has air inside the pores, so it is called: a) vadose zone b) unsaturated zone c) zone of aeration d) all of the foregoing
 12. Which of the following is NOT a common triggering mechanism of slope failure?: a) sudden increase of water, b) changes in slope c) earthquakes d) actually, all of these are common triggering mechanisms
 13. The soil mechanics test that involves rolling moist soil into thin threads is the _____.
 14. Falling-head tests and constant-head tests are used to determine the _____ of rock or soil.
 15. Coherent movements that occur along curved failure surfaces are called: a) creep b) slumps c) earth flows d) translational slides
 16. The capacity of a rock or soil to store water is called _____.
 17. The main effect of human activities that produces sinkhole collapse is: a) vibrations from highways, etc. b) increasing runoff by paving c) lowering the water table d) removing vegetation
 18. The plastic limit and the liquid limit are together referred to as the _____.
 19. Which of the following classifications in the Unified Soil Classification System has the highest strength? a) well graded gravel b) clayey gravel c) silty sand e) silty clay
 20. A map at the scale of 1:24,000 compared to a map at the scale of 1:62,500 is said to be of: a) a smaller scale map b) a larger scale map c) larger scale or smaller scale depending upon the units of measurement d) larger scale or smaller scale depending upon the ground area shown.
 21. The geological term WELL SORTED corresponds to the engineering term _____.
 22. The intrinsic shear strength a material possesses, when the effective normal stress = 0 is called _____.
 23. In a direct-shear apparatus, when the normal force is 10kN, a shear force of 6 kN is required to cause failure, the material's angle of internal friction determine is _____.
 24. Two examples of geologic features and information of importance to foundations on rock include: _____.
 25. A particle-size distribution characterized by roughly equal proportions of all particle-sizes is said to be _____.
-

SECTION B: ESSAY/ COMPUTATIONAL-TYPE QUESTIONS (EACH QUESTION CARRIES 25 MARKS)

1. a) Describe the basis upon which slope failure mechanisms are classified, and **three** examples of slope failure modes.
- b) A field refraction seismic survey carried out at a construction site gave compressional and transverse wave velocities of 900 m s^{-1} and 400 m s^{-1} , respectively. Determine for this material its Poisson's ratio (μ).
- c) Given below is a list of engineering and natural processes that affect the behaviour of the ground:
 - i) Withdrawal of support by surface excavations
 - ii) Dynamic loading
 - iii) Changes in fluid pressure
 - iv) Static loading

Rank the above processes in order of the **most probable** to the **least probable** cause of cracking of structures at the East Park Mall along the Great East Road. Justify your ranking.

2. a) A soil sample from a construction site had a volume of 14.88 cm^3 , a total mass of 28.81 grams, a dry mass of 24.83 grams, and a specific gravity of 2.7. **Determine**, for this sample, its **void ratio**, **porosity** and the **degree of saturation**.

- b) Describe the two main bases, upon which dams are classified. Give **three** examples from each basis.

- c) The diagram in the right shows a dam with a batter in the upstream face. Assuming no water flows on the downstream side, **determine**:

- i) P_1 , P_2 , and P_u , stating the point, at which each of them is acting, or is transmitted to the structure.
- ii) On the basis of these pressures, **comment** on the state of stability of the dam structure.

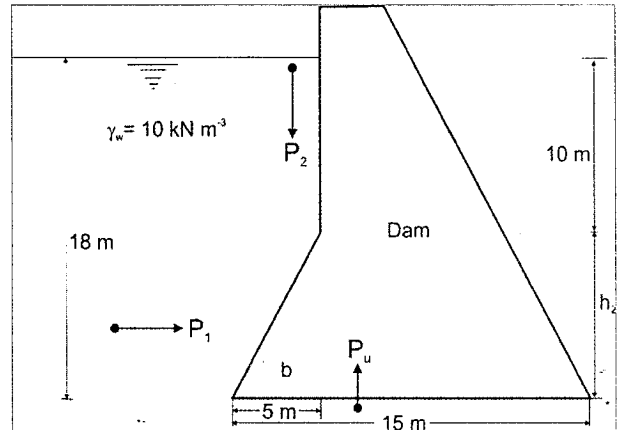

3. a) Discuss the geologic / geotechnical data required in the design of a surface excavation.

- b) The diagram on the right shows a situation revealed by excavation works for a road embankment along the Siavonga Road. For the situation portrayed in this diagram:

- i) **Determine** the factor of safety of the shaded-block, whose strike and dip lengths are 50 m and 30 m, respectively, resting upon a wet shear zone, and with a joint up-dip filled with water.
- ii) Would you describe this block as stable?
- iii) If block is considered unstable, on what basis, and what measures would you need to undertake to ameliorate this situation?
- iv) If block is considered stable, what would be the basis for your decision? What further measures, if any, would you recommend to improve this situation?

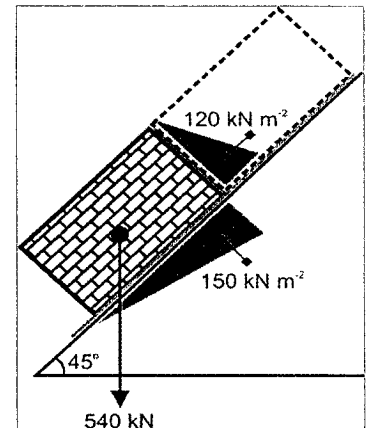

Additional information: unit weight of rock in the slope is 15 kN m^{-3} ; Shear box test results performed on this discontinuity are given in the Table on the right:

σ_N (kNm^{-2})	100	200	300	400
τ (kNm^{-2})	98	139	180	222

4. For purposes of accessing the basement of a planned multi-storey building, a slope trending $N 40^\circ E, 40^\circ NW$ is to be cut. During site investigations, two major sets of discontinuities were mapped with the following average attitudes:

Discontinuity set 1 – $N 70^\circ E, 30^\circ NW$

Discontinuity set 2 – $N 10^\circ E, 20^\circ NW$

Determine:

a) The **direction** and **plunge** of the wedge formed by these discontinuities

b) Whether or not the cut-slope would be stable. Justify your answer.

5. The diagram below shows curves of two soils from a prospective construction site. For each soil, determine:

i) The cumulative percent passing each of the following sieves (in mm);

➤ 0.2, 0.1, 0.08, 0.06, 0.04, and 0.02, for soil A; and

➤ 6, 2, 0.8, 0.4, 0.2, 0.1, 0.08, and 0.06 for soil B.

ii) The quantities (%) of *fine silt; medium silt; coarse silt; fine sand; and medium sand;* for soil A.

iii) The quantities (%) of *fine sand; medium sand; coarse sand; fine gravel; medium gravel* for soil B.

Finally, **classify** the two soils.

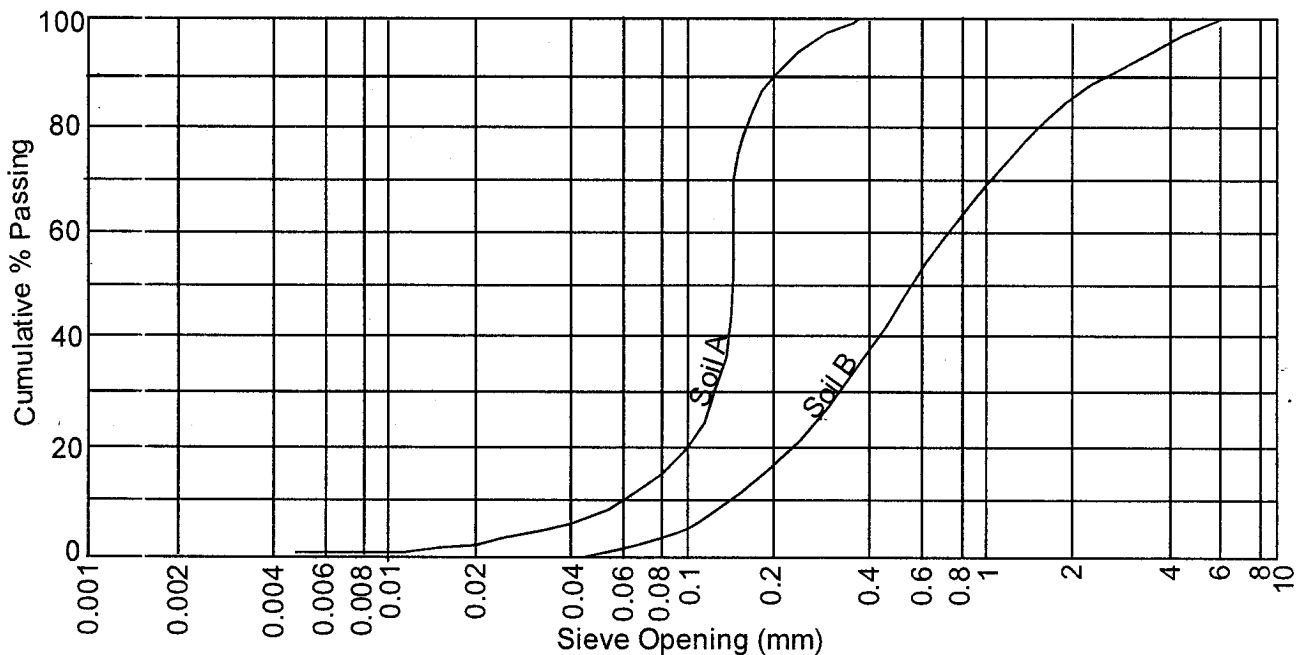

	Fine	Medium	Coarse	Fine	Medium	Coarse	Fine	Medium
CLAY	SILT			SAND			GRAVEL	

END OF EXAMINATION – GOOD LUCK!

**UNIVERSITY OF ZAMBIA
SCHOOL OF MINES**

GGY 5149 – EXPLORATION GEOPHYSICS FINAL EXAMINATION, 2016

ANSWER ANY FIVE (5) QUESTIONS
ALL QUESTIONS CARRY EQUAL MARKS
TIME: THREE (3) HOURS

1. Define the following geophysical terms:
- (a) Magnetic flux density (magnetic induction) and the units
 - (b) Magnetic field strength at the centre of a loop of wire of radius r through which a current I is flowing
 - (c) Resistivity
 - (d) Two types of body waves that travel through an elastic medium, and expression of their velocities
 - (e) Surface Nuclear Magnetic Resonance method
 - (f) Diffusion depth in a Time Domain Electromagnetic (TDEM/TEM) survey
 - (g) Ohm's Law
 - (h) Geometric factor for a Dipole-Dipole Array
 - (i) Principle of Equivalence in a Direct Current (DC) survey
 - (j) Euler Deconvolution

20 marks

2. Prepare a Table of geophysical methods listing the following:
- (a) Geophysical method
 - (b) Type of method, that is, whether passive or active
 - (c) If the method in (b) is active, give one example of the type of source employed
 - (d) Physical property measured
 - (e) Application

20 marks

3. In the planning of a geophysical survey, explain the following:
- (a) Target
 - (b) Line Configuration in ground survey
 - (c) Station interval
 - (d) Spatial aliasing
 - (e) Noise

20 marks

4. (a) Describe the Proton Precession Magnetometer (PPM)
- (b) Prepare a Table of guidelines to qualitative interpretation of magnetic profiles and maps

20 marks

5. Explain how you can employ the Wenner Array to conduct the following surveys:

- (a) A four electrode Vertical Electrical depth Sounding (VES)
- (b) A two dimensional, 2-D, Electrical Imaging.

20 marks

6. (a) Briefly explain the terms give below:

- (i) Reflection Coefficient
- (ii) Transmission Coefficient
- (iii) Radius of the first Fresnel zone
- (iv) Normal Move Out (NMO)
- (v) Rayleigh waves

- (b) Describe the Principle of Convolution in seismic reflection surveying

20 marks

7. In the early 1980's Placid Oil Company of U.S.A conducted a Vibroseis reflection survey in the Luangwa Valley. Data processing included, among others, (1) DEMULTIPLEXING, (2) APPLICATION OF FIELD STATICS, (3) DECONVOLUTION, (4) COMMON MID POINT SORTING, (5) VELOCITY ANALYSIS AND (6) STACKING.

Explain each of the processes listed.

20 marks

END OF EXAMINATION



UNIVERSITY OF ZAMBIA

UNIVERSITY OF ZAMBIA FINAL EXAMINATIONS - AUGUST 2017

GGY 5149 – EXPLORATION GEOPHYSICS FINAL EXAMINATION

INSTRUCTIONS: ANSWER ANY FOUR (4) QUESTIONS (include diagrams where necessary)

QUESTIONS CARRY EQUAL MARKS

TIME: THREE (3) HOURS

1. Explain the following geophysical terms:
 - (i) Spatial Aliasing 5 marks
 - (ii) Magnetic Susceptibility 5 marks
 - (iii) Rayleigh Waves 5 marks
 - (iv) Reflection Coefficient and Transmission Coefficient 5 marks
 - (v) Invasion Zones of an oil well and formation 5 marks

2. Prepare a Table of Geophysical Methods and Main Applications, listing for each method:
 - (i) Geophysical method
 - (ii) Type of method (passive or active)
 - (iii) Physical /properties of interest
 - (iv) Application(s)
 - (v) Types of noise(s) that affect the method 25 marks

3. Describe the principles behind the operation of:
 - (i) (a) Ordinary Proton Precession Magnetometer (PPM) 5 marks
(b) GEM System Incorporated Magnetometer 5 marks
 - (ii) Describe the magnetic survey you conducted along a profile at the Goma Field including the principles behind how to correct for Diurnal Variation 15 marks

4. (a) Explain the following terms as applied in Seismic Reflection methods:
 - (i) First Fresnel Zone 5 marks
 - (ii) Normal Move Out (NMO) 5 marks
 - (b) Describe how to conduct a Marine Seismic Reflection Survey, such as on Lake Tanganyika. 15 marks

5. Explain how to carry out a Direct Current Resistivity Survey using a Wenner Array and a Frequency Domain Electromagnetic Survey using the SLINGRAM configuration as employed for the EM 34 Equipment made by Geonics, in terms of:
- (i) Basic equipment 5 marks
 - (ii) How energy is introduced into the subsurface 5 marks
 - (iii) Ambiguity of results if any 5 marks
 - (iv) Depth sounding 10 marks
6. (a) Geophysical Well Logging is an important contributor to Formation Evaluation, which in turn forms part of Petroleum Engineering.
- (i) Describe the use of a Self Potential (SP) Log as employed in Petroleum Engineering 5 marks
 - (ii) On an SP Log, if the Shale Baseline is positive (+)40mV and the Sand Baseline is negative (-)80mV, what is the shale content of the formation with SP of negative(-)30mV? 5 marks
- (b) Suppose that after running a Density Log in an oil well it is determined that an oil reservoir has an average porosity of 15 percent in an area of 6400 Acres with a net thickness of 100 Feet. Let Initial Oil Saturation be 0.75 and Initial Oil Formation Volume Factor be 1.3 RB/STB. Use the volumetric Oil In Place (OIP) Equation to estimate Original Oil In Place (OOIP) in units of millions of Stock Tank Barrels (STB), explaining how each parameter in the equation is determined. 15 marks

-----END OF EXAMINATION-----

**THE UNIVERSITY OF ZAMBIA
SCHOOL OF MINES**

UNIVERSITY OF ZAMBIA EXAMINATIONS – SEPTEMBER 2016

GGY 5159 – ECONOMIC GEOLOGY OF METALLIFEROUS MINERAL DEPOSITS

PAPER I – THEORY

INSTRUCTIONS: Answer any four questions using sketches wherever possible. All questions carry equal marks.

TIME: Three (3) Hours

- Q1. (a) In August 2016 Zambia had a highly contested general elections that resulted in riots in some parts of the country. Discuss how this issue, if not controlled, would affect the availability of Zambian copper. (5 marks)
- (b) A rock, is epigenetically mineralised by ore fluids resulting in the formation of chalcopyrite, bornite and chalcocite. The key gangue minerals are quartz, calcite and muscovite. A microscopic study reveals that quartz, calcite and muscovite are intergrown but it is apparent that these minerals also occur in both chalcopyrite and bornite as remnants or islands. However, calcite is also found in microveins that cut across both chalcopyrite and bornite. Both chalcopysite and bornite are replaced by covellite along margins and cracks. With brief explanations and a diagram propose a possible paragenetic sequence illustrating the timing for the formation of minerals. (10 marks)
- (c) Classify the following deposit types into either syngenetic or epigenetic and state why: IOCG, stratiform chromite, BIFs, and placer. (6 marks)
- (d) Briefly explain why the Kitumba deposit, being evaluated by Blackthorne Resources in Mumbwa District, is thought to be an IOCG deposit? (4 marks)
- Q2. (a) A slightly acidic meteoric water has percolated downwards through a near vertical quartz and calcite vein composed of pyrite and chalcopyrite, describe the three zones which develop stating the key minerals formed and why. A diagram would be very useful. (10 marks)
- (b) Describe briefly the stratiform chromite deposits in terms of tectonic setting, age, morphology, key ore minerals and gangue minerals and how they formed. (10 marks)
- (c) What is isotope fractionation and how do stable isotopes help in the study of mineral deposits? (5 marks)
- Q3. (a) Describe the product of having a limestone country rock intruded by a hot granitic body in terms of the type of mineralized skarn that develops, skarn mineralogy, ore mineralogy, hydrothermal fluids involved and the alteration that develops. (10 marks)
- (b) State three geophysical methods that may be employed in searching for skarn deposits and why such methods would be suitable. (6 marks)
- (c) What is a primary fluid inclusion and what are the four pieces of information about mineral deposits that would result from the study of such inclusions? (6 marks)
- (d) How are hydrothermal fluids produced through metamorphism? (3 marks)

- Q4. (a) Define the following terms: (6 marks)
- (i) Epithermal Vein
 - (ii) Mesothermal Vein
 - (iii) Hypothermal Vein
- (b) Describe briefly how Ni-Cu sulphide mineralisation is produced through a magmatic process called liquid immiscibility. (10 marks)
- (c) Describe briefly how metal complexation promotes solubility of metals in hydrothermal fluids. (4 marks)
- (d) Briefly describe how adsorption promotes precipitation of metals. (5 marks)
- Q5. (a) Define the following terms (10 marks):
- (i) Cation exchange
 - (ii) Laterite
 - (iii) Oxidation
 - (iv) Dissolution
 - (v) Hydration
- (b) Describe briefly how alluvial diamond deposits would form in terms of source, transport mechanism and deposition site conditions. (10 marks)
- (c) There is so much copper in the Katanga Supergroup of the Zambian Copperbelt and yet the Basement does not contain enough copper to have been the source. Describe briefly the new thought on the possible source of copper. (5 marks)
- Q6. Briefly describe porphyry copper deposits in terms of age, tectonic setting, ore minerals, gangue minerals, alteration and formation. (25 marks)

Good Luck!!!

**THE UNIVERSITY OF ZAMBIA
SCHOOL OF MINES**

UNIVERSITY EXAMINATIONS – SEPTEMBER 2016

**GGY 5159 – ECONOMIC GEOLOGY OF METALLIFEROUS MINERAL
DEPOSITS**

PAPER II – PRACTICAL

INSTRUCTIONS: ANSWER ALL QUESTIONS

TIME: ONE HOUR

You are provided with two polished sections (X and Y). Using the reflected light microscope identify the ore minerals present and describe the observed textures.

-----Good Luck!!!-----

**THE UNIVERSITY OF ZAMBIA
SCHOOL OF MINES**

UNIVERSITY OF ZAMBIA EXAMINATIONS – SEPTEMBER 2017

GGY 5159 – ECONOMIC GEOLOGY OF METALLIFEROUS MINERAL DEPOSITS

PAPER I – THEORY

INSTRUCTIONS: Answer any four questions using sketches wherever possible. All questions carry equal marks.

TIME: Three (3) Hours

- Q1. (a) Discuss in brief why minerals are regarded as the basis for industrialisation. **(5 marks)**
- (b) A vertical vein, composed of quartz, calcite, pyrite, and chalcopyrite, is hosted in quartzite and outcrops. Describe the five zones that would be associated with this vein once it has interacted with meteoric waters and how they develop. Use a sketch and ensure that you state the minerals associated with each zone. **(10 marks)**
- (c) Classify the following deposit types into either syngenetic or epigenetic and state why: IOCG, stratiform chromite, BIFs, and placer. **(6 marks)**
- (d) How would cut-off-grade be affected by the location of an ore deposit with respect to the market? **(4 marks)**
- Q2. (a) Briefly explain how each of the following factors influence metal solubility: (i) metal complexation, (ii) temperature, (iii) pressure, (iv) pH, and (v) Eh. **(10 marks)**
- (b) Describe briefly the stratiform chromite deposits in terms of tectonic setting, age, morphology, key ore minerals and gangue minerals and how they formed. **(10 marks)**
- (c) What is isotope fractionation and how do stable isotopes help in the study of ore deposits? **(5 marks)**
- Q3. (a) Describe the key characteristics of Cu-skarn deposits. **(10 marks)**
- (b) State three geophysical methods that may be employed in searching for skarn deposits and why such methods would be suitable. **(6 marks)**
- (c) What is a primary fluid inclusion and what four pieces of information about mineral deposits would result from the study of such inclusions? **(6 marks)**
- (d) How are hydrothermal fluids produced through metamorphism? **(3 marks)**

- Q4. (a) Define the following terms: **(6 marks)**
(i) Epithermal Vein
(ii) Mesothermal Vein
(iii) Hypothermal Vein
- (b) Describe briefly how Ni-Cu sulphide mineralisation is produced through a magmatic process called liquid immiscibility. **(10 marks)**
- (c) How do petrography and paragenesis help in the study of ore deposits? **(4 marks)**
- (d) Briefly describe how adsorption promotes precipitation of gold. **(5 marks)**
- Q5. Briefly describe porphyry copper deposits in terms of age, tectonic setting, ore minerals, gangue minerals, alteration and formation. **(25 marks)**
- Q6. (a) Define the following terms **(10 marks)**:
(i) Cation exchange
(ii) Laterite
(iii) Oxidation
(iv) Dissolution
(v) Hydration
- (b) Describe briefly how alluvial diamond deposits would form in terms of source, transport mechanism and deposition site conditions. **(10 marks)**
- (c) There is so much copper in the Katanga Supergroup of the Zambian Copperbelt and yet the Basement does not contain enough copper to have been the source. Describe briefly the new thought on the possible source of copper. **(5 marks)**

-----**Good Luck!!!**-----

**THE UNIVERSITY OF ZAMBIA
SCHOOL OF MINES**

UNIVERSITY EXAMINATIONS – SEPTEMBER 2017

GGY 5159 – ECONOMIC GEOLOGY OF METALLIFEROUS MINERAL DEPOSITS

PAPER II – PRACTICAL

INSTRUCTIONS: ANSWER ALL QUESTIONS

TIME: 30 MINUTES

You are provided with one polished sections (X). Using the reflected light microscope identify the ore minerals present and describe the observed textures.

-----**Good Luck!!!**-----

UNIVERSITY OF ZAMBIA

UNIVERSITY OF ZAMBIA EXAMINATIONS - SEPTEMBER 2016

GGY 5179: ECONOMIC GEOLOGY OF ENERGY AND INDUSTRIAL MINERALS

TIME: THREE (3) HOURS

INSTRUCTIONS: ANSWER FIVE QUESTIONS, AT LEAST TWO FROM EACH SECTION. USE A SEPERATE BOOKLET FOR EACH SECTION. ALL QUESTIONS CARRY EQUAL MARKS. USE SKETCHES, TABLES AND DIAGRAMS WHERE NECESSARY FOR A FULL MARK.

SECTION A

- Q1 (a) Explain why hydrocarbons/petroleum is thought to have an organic origin. (3 marks)
- (b) Source rocks contain organic matter in form of kerogen. State the **FOUR (4)** kerogen types, clearly distinguishing each **TYPE** kerogen based on its origin. (6 marks)
- (c) Discuss briefly the principles behind the migration and entrapment of hydrocarbon/petroleum resource. (3 marks)
- (d) Outline briefly the different types of hydrocarbon traps and state under what tectonic and stratigraphic conditions they may form. (4 marks)
- (e) On the basis of your knowledge on the Zambian tectonic and geological setting, suggest any **TWO** areas/regions within Zambia that have potential for hydrocarbon/petroleum resource. **JUSTIFY** your answers. (4 marks)
- Q2 (a) Why is coal referred to as a fossil fuel? Briefly discuss the origin of coal. (5 marks)
- (b) Describe **CONCISELY** the coalification process? State with reasons the stage(s)/rank(s) most suitable for the generation of electricity in a thermal power plant. (7 marks)
- (c) With an aid of the NEAT sketch/diagram, **EXPLAIN** the process of converting coal to electricity. (8 marks)
- Q3 (a) Outline the major processes that concentrate uranium. (4 marks)
- (b) State with reasons why effusive rocks tend to be more uraniferous. (3 marks)
- (c) Discuss with NEAT sketch/diagrams, the unconformity related uranium deposit according to the metals present and the hydrological conditions. (7 marks)
- (d) With an aid of a sketch/diagram, describe how uranium ore is used in the generation of electricity. (6 marks)

SECTION B

- Q4 (a) Define comprehensively what an industrial mineral is. (2 marks)
- (b) How do the following factors affect the commercial production of industrial minerals? (i) Geographic location, (ii) Labour rates, (iii) Transportation, and (iv) Environmental Regulations. (8 marks)
- (c) Define the following: (i) Identified resource, (ii) Reserve, (iii) Inferred reserve, and (iv) Speculative resource. (4 marks)
- (d) Provide two industrial minerals examples for each of the following classes of industrial minerals: (i) igneous, (ii) sedimentary, and (iii) vein & replacement. (6 marks)
- Q5 (a) State four tectonic settings for industrial minerals and two industrial minerals associated with each setting. (6 marks)
- (b) Using examples distinguish natural aggregate from artificial aggregate. (3 marks)
- (c) What material constitutes and what purpose does each of the following layers of the road serve?: (i) Sub-base, (ii) Road base, (iii) Base course, (iv) Wearing course. (4 marks)
- (d) Explain briefly how sand and gravel would geologically be produced. (7 marks)
- Q6 (a) Define cement and calcination. (2 marks)
- (b) Name and discuss four factors which are considered in locating a cement plant. (8 marks)
- (c) Name and describe briefly, justifying your answers, three key technics you would employ in assessing a limestone deposit for cement production. (6 marks)
- (d) State and discuss two very important factors which have made Dangote cement highly competitive in price. (4 marks)
- Q7 (a) State the two types of gypsum and how each is produced. (4 marks)
- (b) Describe briefly how gypsum forms geologically. (6 marks)
- (c) Describe briefly how gypsum board is manufactured. (4 marks)
- (d) State and discuss three factors gypsum board so useful in the construction industry. (6 marks)

END OF EXAM



UNIVERSITY OF ZAMBIA

UNIVERSITY OF ZAMBIA DEFERRED EXAMINATIONS – SEPTEMBER 2017

GGY 5179-ECONOMIC GEOLOGY OF ENERGY AND INDUSTRIAL MINERAL DEPOSITS

INSTRUCTIONS: THERE ARE TWO SECTIONS IN THIS QUESTION PAPER. ANSWER FIVE (5) QUESTIONS AND AT LEAST TWO (2) FROM EACH SECTION. ALL QUESTIONS CARRY EQUAL MARKS. USE A SEPARATE BOOKLET FOR EACH SECTION. WELL LABELLED SKETCHES AND DIAGRAMS ARE REQUIRED WHERE NECESSARY FOR A FULL MARK

TIME: THREE (3) HOURS

SECTION A (Energy Mineral Deposits)

- Q1. (a) You are part of the petroleum exploration team exploring for petroleum resource in the Northern part of Zambia. Briefly state the **five (5)** major geological conditions necessary for the formation and accumulation of this resource [5 marks]
- (b) Write brief notes on the following:
- (i) Formation of petroleum resource [4 marks]
 - (ii) Types of petroleum migration processes [4 marks]
 - (iii) Application of *Pseudo Van Krevelen diagram* in source rock evaluation [4 marks]
- (c) Describe briefly how natural gas is used to generate electricity [3 marks]
- Q2. (a) Differentiate between the following:
- (i) Autochthonous and allochthonous coal deposit [2 marks]
 - (ii) Peatification and coalification processes [2 marks]
- (b) State the **three (3)** coal maceral groups, including their descriptions, lithotype and origin [9 marks]
- (c) Coal in Maamba area of Southern Province of Zambia is generally banded in nature. Describe its major lithotypes and their characteristics [4 marks]
- (d) How is coal converted into electricity [3 marks]
- Q3. (a) Describe briefly the **three (3)** major geological processes that concentrate uranium deposits [6 marks]
- (b) Uranium deposits in the Mid-Zambezi Valley Basin is concentrated in the Upper Karoo Formations. Is the deposition and accumulation of uranium in these formations of ingress or egress type or both? Explain your reasoning [6 marks]
- (c) With the aid of a well labelled diagram, describe the uranium fuel cycle [4 marks]
- (d) How is nuclear energy produced and used to generate electricity [4 marks]

SECTION B (Industrial Mineral Deposits)

- Q4. (a) Define the following: (i) development minerals, (ii) natural aggregate, (iii) lightweight aggregate, (iv) cement, and (v) calcination. [5 marks]
- (b) How would each of the following factors affect the commercial production of industrial minerals? (i) plant location, (ii) political stability, (iii) taxes, and (iv) market. [8 marks]
- (c) Define the following with respect to industrial minerals: (i) resource, (ii) reserve, (iii) proven reserve, and (iv) hypothetical resource. [4 marks]
- (d) Provide two industrial rock examples for each of the following classes of industrial minerals: (i) igneous, (ii) sedimentary, and (iii) vein & replacement. [3 marks].
- Q5. (a) Distinguish limestone from lime. (3 marks)
- (b) Describe how limestone and marble are geologically formed. [7 marks]
- (c) Name and describe briefly, justifying your answers, three key techniques you would employ in assessing the quality of a limestone deposit for agriculture. [6 marks]
- (d) Describe briefly how limestone for chicken feed is processed by Uniturtle Industries. What type of limestone is used for chicken feed and why? [4 marks]
- Q6. (a) What is talc? [2 marks]
- (b) State and briefly describe three ways in talc is naturally formed. [6 marks]
- (c) State three key uses of talc providing reasons why it is used for such? [6 marks]
- (d) What is gypsum? [2 marks]
- (e) Describe briefly how flue-gas desulfurized gypsum is produced. [4 marks]

-----End of Examination-----



The University of Zambia

UNIVERSITY OF ZAMBIA EXAMINATION - 2016 SCHOOL OF MINES

GGY5189 – HYDROGEOLOGY FINAL EXAMINATION

ANSWER: ANY FIVE QUESTIONS

ALL QUESTIONS CARRY EQUAL MARKS

TIME: THREE (3) HOURS

1. Explain, briefly, the following terms:

- (a) Groundwater
- (b) Phreatic aquifer
- (c) Storage coefficient of confined aquifer
- (d) Aquiclude
- (e) Well efficiency
- (f) Cone of depression
- (g) Pump test
- (h) Vadose zone
- (i) Aquifer loss
- (j) Piezometric surface

20 marks

2. a) Hydro-geophysics uses different geophysical approaches to outline and map spatial distributions of groundwater. Two methods gaining popularity is TDEM (Time Domain Electro-magnetism) and MRS (Magnetic Resonance Sounding). Describe the eminent differences in the two methods, methods of deployment and variables of interest.

b) Archie's law essentially provides the link between geophysics and hydrogeology. Define Archie's law and its significance in hydrogeology.

20 marks

3. a) Briefly explain the following:
- Numerical models
 - Two basic types of boundary conditions (given in class) required to solve a groundwater flow equation
 - A Solution, in two dimensions, to the finite-difference equation for the steady-state case (Laplace equation), in the absence of recharge. Note: $\Delta x = \Delta y$
- b) List steps required in the development of a ground-water model

20 Marks

4. (a) List 3 assumptions of the continuity equation.
- (b) Simplify the continuity equation for two cases: (i) Homogeneous and anisotropic medium, and (ii) Homogeneous and isotropic medium, steady-state conditions.
- (c) In a horizontal, confined aquifer, hydraulic conductivity changes in the direction of flow linearly from $K_a=0.2$ m/d at point A to $K_b=0.1$ m/d at point B, and porosity changes linearly from $n_a=0.1$ to $n_b=0.2$ (A and B are along a typical flow path). Is the velocity of ground water constant along the flow path? Why or why not?

20 Marks

5. (a) The aquifer below is 1.30 km wide. The effective porosity is 0.290 and the hydraulic conductivity equals 83.0 m/d. Water containing a dangerous radioactive isotope of plutonium is dumped (accidentally of course) into well A. How long does it take for the plutonium to show up in Well B? Assume that the plutonium is carried along at the same speed as the groundwater.

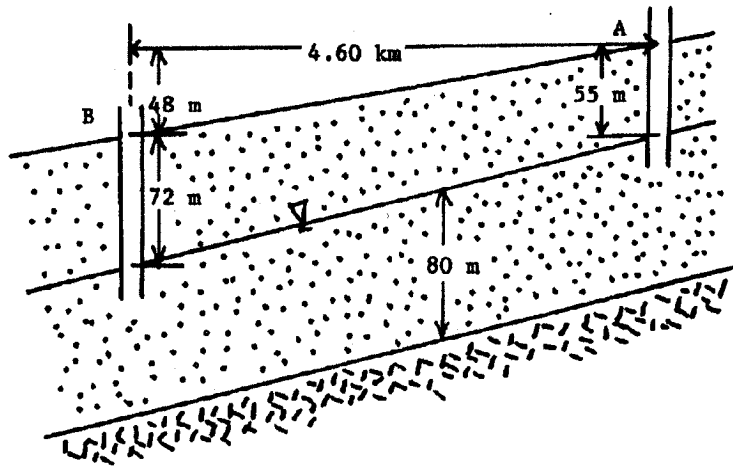

b) A unconfined aquifer with a storativity of 0.13 has an area of 123 km^2 . The water table drops 5.23 m during a drought season. How much water was lost? If the same aquifer had been confined with a storativity of 0.0005, what change in the amount of water in storage would have resulted ?

c) An undisturbed sample of a medium sand weighs 484.68g. The core of the undisturbed sample is 6 cm in diameter and 10.61 cm in height. The sample is over-dried for 24 hrs at 110°C to remove the water content. At the end of the 24 hrs, the core sample weights 447.32 g. Determine the bulk density, void ratio, water content, porosity, and saturation percentage of the sample?

20 Marks

6. a) Two resistivity soundings were performed over a crystalline basement area in Southern Zambia as below.

TRANSECT 1

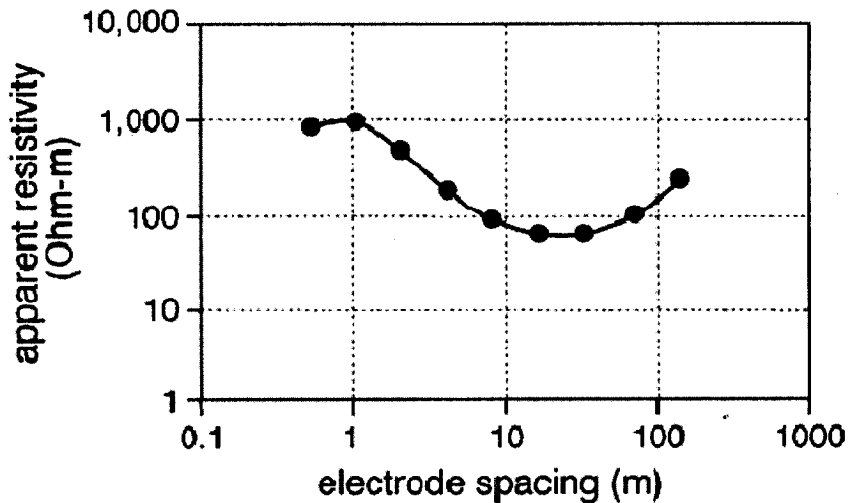

TRANSECT 2

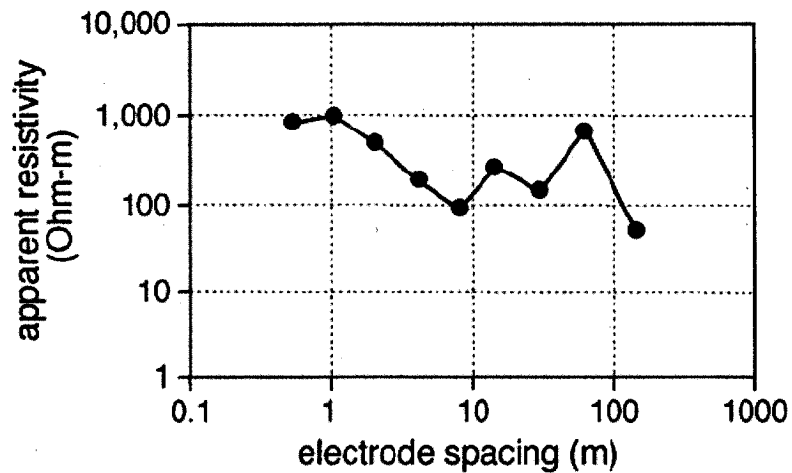

- i) Which transect would you use for your interpretation? Give reasons for the choice by comparing the two plots.
 - ii) Draw your proposed earth layered model based on your answer in part (i).
 - iii) Suggest a target depth for drilling.
- b) Describe a general procedure of how you would conduct a resistivity vertical electrical survey (VES).
- c) State at least four advantages and disadvantage of resistivity VES method.

20 Marks

7. Indicate whether the following statements are true or false. Qualify your answer

- a) With other conditions being the same, the drawdown cone in an aquifer with a high transmissivity will slope more steeply in an aquifer with a low transmissivity.
- b) Poor well efficiency affects the drawdown response seen in both the pumped well and any observation wells that may be present.
- c) Pumped wells recover (when the pump is switched off) as if they are 100% efficient.
- d) Increases in atmospheric pressure above confined aquifers will cause water levels in piezometers to decline.
- e) The compressibility of water tends to be higher in silts than in sands.
- f) A groundwater divide is an example of a constant head boundary.
- g) The tension saturated zone is fully saturated and the fluid pressure is less than atmospheric.

- h) Where transmissivity and storativity are denoted by T and S respectively, a fractured granite aquifer is normally characterised by i) low T, low S, ii) high T, low S, iii) low T, high S, iv) high T, high S.
- i) The Jacob straight line approximation for analysing pumping test data is least likely to be valid for data obtained i) in the pumping well ii) in an observation well iii) for high well yields, iv) for low well yields.
- j) Groundwater is always pure because soil filters out any impurities

20 Marks

END



UNIVERSITY OF ZAMBIA EXAMINATION

SCHOOL OF MINES

GGY5189 – HYDROGEOLOGY FINAL EXAMINATION

AUGUST, 2017

ANSWER: ANY FIVE QUESTIONS

QUESTIONS CARRY EQUAL MARKS

TIME: THREE (3) HOURS

1. Explain, briefly, the following terms and where appropriate use diagrams:

- (a) Groundwater
- (b) Phreatic aquifer
- (c) Storativity
- (d) Aquitard
- (e) Well efficiency
- (f) Cone of depression
- (g) Pump test
- (h) Vadose zone
- (i) Aquifer loss
- (j) Specific Storage

Total = 20 Marks

2. A total area of 6,250 ha are irrigated from alluvial groundwater. Assume irrigation demand of 1.5 litre/sec per ha continuously for 300 days per year. The 65 days without irrigation occur between December and February during the rainy season. Assume that the irrigation water is pumped from the alluvial sands in the active river channel, and that this water is at the expense of river flow. The spreadsheet (last page) provides a water balance data.

- 1. Calculate the monthly water balance for each month. 5 Marks
- 2. Calculate the monthly water deficit in the alluvial aquifer. 5 Marks
- 3. Calculate the monthly river flow with groundwater abstraction. 5 Marks
- 4. Calculate the annual totals for all columns. 5 Marks

Total = 20 Marks

3. (a) List three assumptions of the continuity equation 3 Marks
- (b) Derive the continuity equation under non-steady conditions 7 Marks
- (c) In the confined aquifer illustrated below, there is a well that pumps water at a steady rate of $Q = 500 \text{ m}^3/\text{day}$. Nearby are two observation wells A and B at radial distances of 10 m and 25 m, respectively. The heads in these wells are $h_A = 80.0 \text{ m}$, and $h_B = 82.0 \text{ m}$. Given this information, estimate T and K for the aquifer. Predict the head at the outerwall of the well screen, which has radius $r_w = 0.5 \text{ m}$. 10 Marks

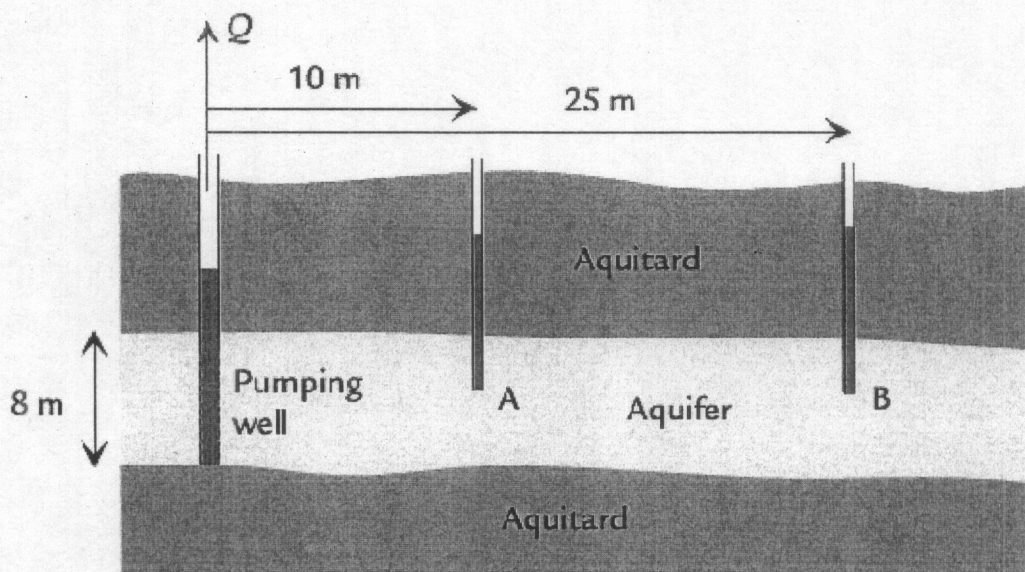

Total = 20 Marks

4. Indicate whether the following statements are true or false.
- With other conditions being the same, the drawdown cone in an aquifer with a high storativity will slope more steeply than in an aquifer with a low storativity.
 - Pumped wells recover (when the pump is switched off) as if they are 100% efficient
 - The compressibility of water tends to be higher in sandstone than in siltstone.
 - The storativity is a dimensionless quantity and is higher in a confined aquifer than unconfined

- e) Specific Capacity can be used as a measure of how well the borehole is constructed and developed (well performance).
- f) The compressibility of water tends to be higher in silts than in sands.
- g) Pumps in production boreholes must be placed in the screen zone.
- h) The tension saturated zone is fully saturated and the fluid pressure is less than atmospheric.
- i) Where transmissivity and storativity are denoted by T and S respectively, a fractured granite aquifer is normally characterised by low T, high S.
- j) The Jacob-Cooper straight line approximation for analysing pumping test data is least likely to be valid for data obtained in an observation well and pumping well.

20 Marks

5. a) Explain the differences between the processes by which water is released from storage when groundwater is abstracted from a confined aquifer and an unconfined aquifer. (5 Marks)

- b) The drawdown in a confined aquifer due to constant pumping rate Q can be described by the equation:

$$s = \frac{Q}{4\pi T} W(u) , \text{ where } u = \frac{r^2 S}{4Tt}$$

The well function can be expanded as a series

$$W(u) = -0.5772 - \ln u + u - \frac{u^2}{2 \cdot 2!} \dots$$

Show that for $U < 0.01$, the drawdown can be expressed to a good approximation by Jacob-cooper equation:

$$s = \frac{2.3Q}{4\pi T} \log \frac{2.25Tt}{r^2 S}$$

(5 Marks)

- (c) The following resistivity sounding was taken in a sedimentary system as below. Give an interpretation of the profile. (Hint: Draw a sketch with layers and resistivity values – if possible some lithologies as well).

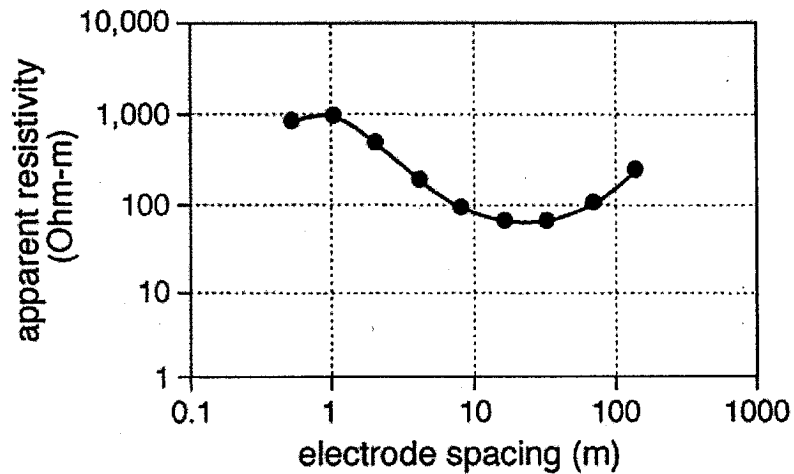

(10 Marks)

6. (a) Determine the transmissivity from the following recovery data

Q = 150 m ³ /hr					
Pumping time = 610 minutes					
t' (min)	S' (m)	t' (min)	S' (m)	t' (min)	S' (m)
18	12.93	48	7.22	78	4.73
23	11.63	53	6.61	83	4.50
28	10.36	58	6.20	88	4.20
33	9.41	63	5.73	93	4.00
38	8.13	68	5.32	100	3.70
43	7.81	73	5.05	105	3.53

You will need the following equation: $T = \frac{2.3Q}{4\pi\Delta S}$

Where,

- ΔS is residual drawdown per log cycle t/t'
- t' time since pumping stopped
- t total pumping time
- S' residual drawdown

(15 Marks)

(b) In previous studies, the transmissivity was found to be 300 m²/day, why do you think the transmissivity you found is much smaller?

(5 Marks)

7. Use the figure below to answer the following questions:

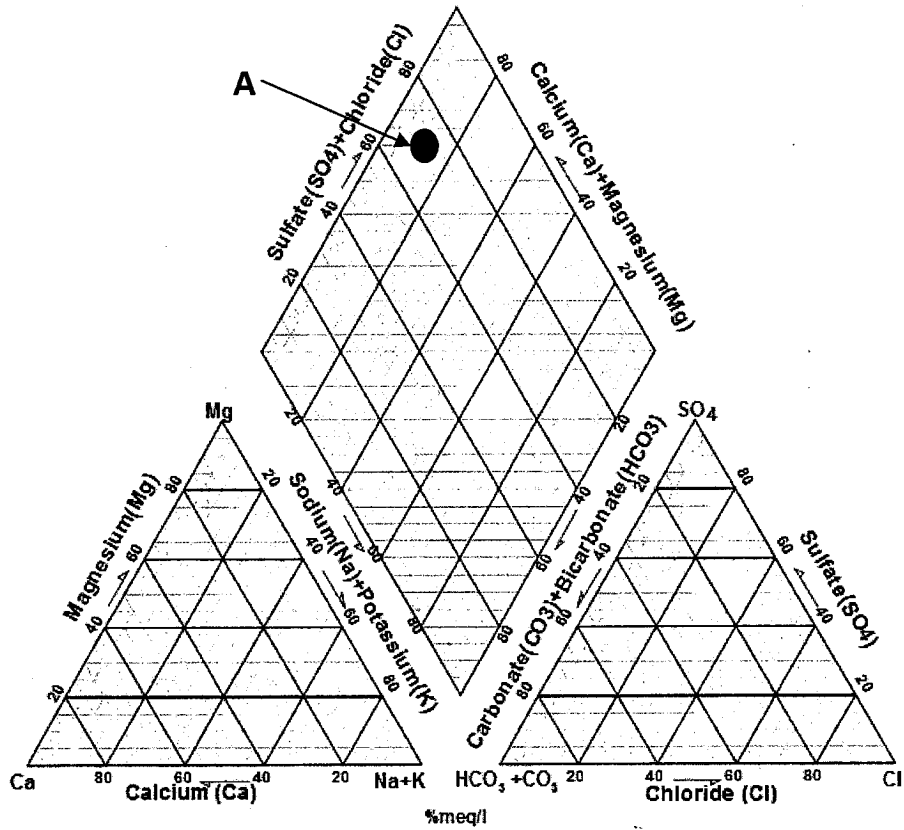

(a) What type of water is this sample A? 5 Marks

(b) Name at least two possible water rock interactions that may result in this water type? 5 Marks

(c) Determine if the water quality analysis below is in ionic balance

TEMP	15	C
HCO ₃ ⁻	198.4	mg/L
Cl ⁻	114.9	mg/L
K ⁺	9.9	mg/L
Ca ⁺²	74.4	mg/L
Mg ⁺²	18.1	mg/L
Na ⁺	130	mg/L
SO ₄ ⁻²	227.1	mg/L
Total Dissolved Solids	733	mg/L
Alkalinity as CaCO ₃	162.6	mg/L
pH	7.37	units

10 Marks

.....END (GOOD LUCK).....

Month	(a) Rainfall (mm)	(b) River flow: no GW abstraction (m ³ /s)	(c) GW abstraction (m ³ /s)	(d) Monthly water balance (m ³ /s)	(e) Alluvial aquifer deficit m ³ /sec nb: max < 0 e (previous) + d	(f) River flow with GW abstraction m ³ /s
Previous dry season					Brought forward	-28
September	0	0	-6.5			
October	17	0.2	-6.5			
November	39	5.3	-6.5			
December	73	27.5	-3.2			
January	129	88.7	0			
February	108	42.1	-1.7			
March	19	5	-6.5			
April	0	1.9	-6.5			
May	0	1.4	-6.5			
June	0	1.1	-6.5			
July	0	0.7	-6.5			
August	0	0.5	-6.5			
Annual Totals						

(USE THIS SPREADSHEET FOR QUESTION 2 AND SUBMIT WITH THE EXAM SHEET)

THE UNIVERSITY OF ZAMBIA
UNIVERSITY EXAMINATIONS - SEPTEMBER, 2016

MET 5239

IRON AND STEEL MAKING

Time : THREE hours

Answer: FIVE (5) QUESTIONS: QUESTION ONE (1) IS COMPULSORY

1.

Consider the inputs and outputs of the blast furnace as follows

Inputs

Iron ore (wt %): $\text{Fe}_2\text{O}_3 = 79$, $\text{SiO}_2 = 12$, $\text{MnO} = 1.8$, $\text{Al}_2\text{O}_3 = 3$, and $\text{H}_2\text{O} = 4.2$

Coke (wt %): $\text{C} = 88$, $\text{SiO}_2 = 10$, $\text{Al}_2\text{O}_3 = 1$ and $\text{FeS} = 1$

Flux (total wt 500kg) (wt %): $\text{CaCO}_3 = 97.5$, $\text{MgCO}_3 = 1.5$ and $\text{SiO}_2 = 1$

Outputs

Pig Iron (wt %): $\text{Fe} = 93.7$, $\text{C} = 3.9$, $\text{Si} = 1.2$, and $\text{Mn} = 1.2$

Top gas composition ($2400\text{m}^3/\text{ton}$ of iron ore): $\text{CO} = 25\%$, $\text{CO}_2 = 13.5\%$, $\text{H}_2\text{O} = 4\%$, $\text{N}_2 = 57.5\%$

Assume some iron is lost as FeO in slag. Per ton of pig iron there is 1.82 tons of ore is used.

Determine

- a) Amount of coke / ton of pig iron. *(5 marks)*
- b) Mass and composition of slag / ton of pig iron. *(12 marks)*
- c) Perform oxygen balance and comment. *(11 marks)*

Atomic weights: $\text{Fe} = 56.0$, $\text{H} = 1.0$, $\text{O} = 16.0$, $\text{Ca} = 40.0$, $\text{C} = 12.0$, $\text{Si} = 28.0$, $\text{Al} = 27.0$, $\text{Mn} = 55.0$, $\text{P} = 31.0$, $\text{Mg} = 24.0$ and $\text{S} = 32.0$

2.

- (a) What is an 'Ore reserve' according to the JORC code definition?(1 mark)
- (b) Mention two (2) main iron ores which their chemical formulae.(2 marks)
- (c) Give five (5) factors on which selection of iron ores for metal production depends on.(4 marks)
- (d) List and describe *briefly* four concentration processes that are commonly used for iron treating iron ore.(4 marks)
- (e) List and describe *briefly* four (4) stages of pelletizing.(4 marks)
- (f) What flux is commonly used in the production of iron and steel, and what does it do? (1 mark)
- (g) What is the difference between self-fluxed and super-fluxed in sinter? (2 marks)

3.

- (a) Distinguish the following pair of terms as applied to iron and steelmaking in 2 to 4 sentences each.
 - i. Iron and steel. (2 marks)
 - ii. Pig iron and direct reduced iron. (2 marks)
 - iii. Flux and slag. (2 marks)
- (b) Give Six (6) properties of metallurgical coke that are required in relation to BF operation. (4 marks).
- (c) In a sentence or two, explain why controlled porosity is imperative in metallurgical coke. (2 marks)
- (d) Blast furnace is the oldest technology of producing iron from iron oxide ore. This technology has been facing some challenges for decades which has prompted researchers to invent other technologies of producing 'molten iron' of similar chemical composition as obtained in blast furnace.
 - i. Mention four challenges of producing iron via blast furnace and write *brief* notes on each.(4 marks)
 - ii. Name two alternative processes of producing liquid iron.(2 mark)

4.

(a) With the aid of neat diagrams, describe *briefly* the three types of basic oxygen converters. **(6 marks)**

(b) With the aid of neat diagrams, give description of each stage of basic operation sequence of a basic oxygen converter. **(6 marks)**

Note: Comment *briefly* on the feed materials and oxidation of elements at an appropriate stage of operation sequence.

(c) Suppose you are the BOF shift in-charge and after sampling you find that your molten steel has more carbon than specified in your production schedule, what would you do lower carbon content in your steel? **(1 mark)**

(d) For another heat you sample your molten steel and find that it has more phosphorous than specified in your production schedule

i. What would you do to lower phosphorous content in your steel? **(2 marks)**

ii. Mention conditions that support oxidation of phosphorous you would aim for? **(3 marks)**

5.

(a) Slag plays a vital role in steelmaking. It is commonly said 'a well-made slag makes steel'

i. Give six functions of slag in steelmaking. **(4 marks)**

ii. Mention the physical and chemical properties of slag that are critical in steel making. **(3 marks)**

(b) In normal steelmaking by BOF oxygen reacts which dissolved carbon to produce carbon monoxide. The resultant gas, CO, has high calorific value which can be combusted to produce heat. Modern BOF have post combustion facilities to combust CO. Mention two advantages and two disadvantages of post combustion reaction in BOF. **(3 marks)**

(c) Another important thing which is practiced in modern BOF is the slag splashing. This has some advantages and disadvantages. Mention three advantages and disadvantages of slag splashing. **(4 marks)**

(d) Describe two types of electric arc furnaces in 2 to 4 sentences. **(4 marks)**

6.

Hematite ore of 83% Fe₂O₃ is reduced in blast furnace using coke of 88% C. The reduction equation is

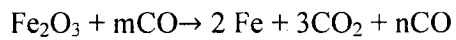

It is required to produce exit gas of composition CO: CO₂ 7: 4. The pig iron analysis shows 94% Fe and 4% C and the rest is ignored.

Determine

- a) Reduction equation, balanced with whole numbers. (3 marks)
- b) Amount of coke per ton of P.I. (5 marks)
- c) Amount of air required per ton of P.I to burn C of coke to produce CO. (5 marks)
- d) Percentage composition of exit gas. (5 marks)

**END OF EXAMINATION
GOOD LUCK!**

UNIVERSITY OF ZAMBIA
UNIVERSITY EXAMINATION – SEPTEMBER, 2017

MET 5239: IRON AND STEEL MAKING

Time : Three (3) hours

Instructions: Answer five (5) questions. Question one (1) is compulsory

Where applicable, all calculations are to be done correct to three decimal places.

1.

Consider the inputs and outputs of the blast furnace as shown in the table below. The coke consumption is taken to be 600kg / ton of pig iron.

	Compounds / Element	Fe ₂ O ₃	Fe	SiO ₂	Si	MnO	Mn	P ₂ O ₅	P	Al ₂ O ₃	CaCO ₃	C	Total
Inputs	Iron ore (wt%)	78		12.1		2.4		1.5		6			100
	Coke (Wt%)			5								95	100
	Flux (Wt%)			3							97		100
	Blast (Wt% or Vol%)	blast air of certain composition of nitrogen and oxygen											100
Outputs	Pig Iron (Wt%)		93		2.9		0.4		0.4			3.3	100
	Slag (Wt%)	Slag of various composition											100
	Offtake gase (wt or vol%)	Offtake gas of various composition											100

During smelting only 0.5% of the total Fe charged goes to slag as FeO. The CO:CO₂ ratio in the top gas is 2.5:1. The amount of flux is one quarter of the total amount of iron ore.

Calculate:

- (i) The weight of ore per tonne pig iron. [6 marks]
- (ii) The weight of slag per tonne pig iron and % composition. [12 marks]
- (iii) The volume of blast. [10 marks]

Atomic weights: Fe = 56.0, O = 16.0, Ca = 40.0, C = 12.0, Si = 28.0, Al = 27.0, Mn = 55.0, P = 31.0.

1 mol. = 22.4 x 10⁻³ m³ of gas.

[28 Marks]

2.

- (a) Suppose you are contemplating on investing in an extraction company that would be extracting iron from iron ore. Give and explain four (4) factors you would consider when selecting iron ore from which iron can be extracted economically? **[6 marks]**
- (b) Give three (3) reasons that have led to the conversion of iron ore deposits that were classified as iron ore resources a long time ago to iron ore reserves today. **[3 marks]**
- (c) Describe the iron ore concentration by the following techniques **[9 marks]**
 - i. Jigging
 - ii. Spirals
 - iii. Dense medium separation

[18 Marks]

3.]

- (a) Discuss why it is desirable to agglomerate iron ore feed to blast furnace. **[2 marks]**
- (b) Describe pelletising process of iron ore fines. **[5 marks]**
- (c) Suppose you are a process manager working in a blast furnace. Iron ore feed to this blast furnace is bought from iron ore suppliers. You are called by the chief executive officer (CEO), who has limited technical knowledge about ironmaking, to explain why it is more beneficial to buy sinters than pellets as source of iron for your blast furnace operations given that sinters are 1% more expensive than pellets. Give technical reason(s) to convince this CEO why you should continual buying sinters instead of pellets. **[5 marks]**
- (d) Briefly describe, with the aid of blast furnace diagram and chemical reaction equations, the reduction of iron oxide (use hematite as the primary iron ore oxide) in the blast furnace. **[6 marks]**

[18 Marks]

4.

- (a) Describe the by-product coke making process during the production of metallurgical coke. **[6 marks]**
- (b) Give and explain four (4) chemical and three (3) physical properties of metallurgical coke that are important for blast furnace operations. **[10 marks]**

- (c) Apart from coke, name four (4) other sources of energy that are used in ironmaking (blast furnace). **[2 marks]**

[18 Marks]

5.]

- (a) There has been massive research in the past decades to develop and design new iron making processes other than the traditional blast furnace iron making route. Some of the new processes are now commercialized others are still in a pilot plant stage. State and explain four (4) reasons that have necessitated this massive research on alternative ironmaking processes away from blast furnace. **[4 marks]**
- (b) SL/RN process is a well-known process of producing sponge iron also known as direct reduced iron (DRI) from iron oxide using coal. Reducing gases are produced in the process. Explain with the aid of chemical reaction equations and diagram(s) the production of DRI by SL/RN process. **[8 marks]**
- (c) Explain in details how different is the blast furnace from COREX process as applied to iron making. **[6 marks]**

[18 Marks]

6.

- (a) Secondary steel making also known as ladle metallurgy is an intermediate stage between primary steel making and casting. Mention four objectives of secondary steelmaking. **[2 marks]**
- (b) Steel making in electric arc furnace (EAF) is a batch process. Each batch is called a heat just like in basic oxygen furnace.
- Write brief notes about tap-to-tap cycle of EAF. **[6 marks]**
 - How would you ensure less power consumption, fast melting and fast raising of temperature in EAF? **[2 marks]**
- (c) Suppose the steel melt shop is composed of electric arc furnace (EAF), ladle refining furnace (LRF) and casting.

- i. How would you refine molten steel in EAF to remove elements such as phosphorus, sulphur, and carbon if molten steel has to go through the ladle refining stage before casting? **[4 marks]**
- ii. How different would you refine (removing elements such as C, P, S as well as adjusting the chemical composition to conform to the prescribed production schedule) molten steel in EAF that has to go direct from EAF to casting. **[4 marks]**. *Note: This is usually the case when LRF has either mechanical or electrical problem.*

[18 Marks]

7.

- (a) How is primary steel making different from secondary steelmaking? **[3 marks]**
- (b) Why is it important to saturate slag with MgO in basic oxygen furnace and electric arc furnace? **[2 marks]**
- (c) Phosphorous has detrimental effects to physical properties of steel. It is required to remove as much of it from molten pig iron and also from molten steel as possible. Write two chemical reaction equations that describe the removal of phosphorus from the removal of phosphorus from the molten steel bath. **[2 mark]**
- (d) What are the three conditions that favours the removal of phosphorous in molten steel bath? **[3 marks]**
- (e) There is a saying in steelmaking that goes like 'a well-made slag makes steel.'
 - i. What is your interpretation of the above saying? **[2 marks]**
 - ii. Mention and describe the physical and chemical properties of slag that are critical in steel making. **[6 marks]**

[18 Marks]

== END OF EXAMINATION IN MET 5239 ==

WISH YOU ALL THE BEST!

THE UNIVERSITY OF ZAMBIA

UNIVERSITY EXAMINATIONS – SEPTEMBER 2016

MET 5259

Special Topics in Extractive Metallurgy

Answer: Five Questions

Time: 3 hours

=====

1.

- a) What is scrap? [2 Marks]
- b) What is the importance of metal recycling? [2 Marks]
- c) What are the two sources from which scrap iron and steel originate? [2 Marks]
- d) Why is the material classification important in scrap metal recycling? [2 Marks]
- e) Describe the methods of recycling copper, zinc and gold in the relevant industries. [12 Marks]

2.

- a) Calculate top gas composition for an ideal gas blast furnace operating with a mixture of Fe_2O_3 and coke. Coke is 90% C and is consumed at the rate 475 kg/ton of iron. Oxygen is introduced at the rate of 350 kg/1000kg iron. Hot metal has 4.5% C. [9 Marks]
- b) Describe the steps involved in the preliminary processing of electronic scrap. [7 Marks]
- c) In a converter steel making process about 30% of steel scrap may be used. What are the three functions of the added steel scrap? [3 Marks]
- d) What are the main problems of using scrap in steel making process? [2 Marks]

3.

- a) What are the three main objectives of solvent extraction? [3 Marks]
- b) Mention five properties a successful copper extractant must have. [5 Marks]
- c) What is the essential difference between electrorefining and electrowinning? [2 Marks]
- d) What are the two main sources of impurities in cathodes obtained through electrowinning? [2 Marks]
- e) Why are electrowon cathodes lighter than electro-refining cathodes? [2 Marks]
- f) Why are cathode current efficiencies in electrowinning plants rather low? [3 Marks]
- g) The most difficult problem in copper-SX circuits is the crud formation. What is crud and how could it be minimised in practice? [3 Marks]

4.

(a) Convert the following parameters into numerical values for their equivalent blast furnace model variables: [9 Marks]

Operating parameters	Model variable
(i) Ore charge: hematite, Fe_2O_3	$\left(\frac{\text{O}}{\text{Fe}}\right)^x$
(ii) Blast: 1200 Nm^3 dry air per tonne of product Fe	n_{O}^{B}
(iii) Pig iron: 5 % C	$\left(\frac{\text{C}}{\text{Fe}}\right)^m$
(i) Total carbon in charge: 460 kg dry coke (90 % C) and 50 kg oil (85 % C) per tonne of Fe.	$n_{\text{C}}^{\text{i}} = n_{\text{C}}^{\text{o}}$
(v) Active carbon from (iii) and (iv)	n_{C}^{A}
(vi) Carbon in top gas from (v)	n_{C}^{g}
(vii) Top gas composition: 23.9 Vol. % CO , 20.5 % CO_2 , 55.6 % N_2	$\left(\frac{\text{O}}{\text{C}}\right)^{\text{g}}$
(viii) Quantity of CO and CO_2 in top gas from (vi) and (vii)	$n_{\text{CO}}^{\text{g}}, n_{\text{CO}_2}^{\text{g}}$

(b) The heat demand, D of a hematite-charged blast furnace is $560\,000 \text{ kJ}$ per kg mole of product Fe. The total carbon in charge is 600 kg per tonne of product Fe. The pig iron product contains 5 % C. Calculate:

- (i) The volume of blast air (Nm^3 per tonne Fe) which is required to keep this furnace operating at a steady state. [5 Marks]
- (ii) Composition of the top gas. [6 Marks]

5.

(a) Describe in general the solvent extraction (SX) process as applied in the recovery of copper from its ores. [1 Mark]

- Describe: (i) Sulphuric acid leaching system; [3 Marks]
(ii) Ammonia leaching system; [3 Marks]
(iii) Concentrated chloride leaching system. [3 Marks]
- (b) Give a comparison of properties for reagents based on ketoximes, modified aldoximes and ketoxime/aldoxime mixtures. [6 Marks]
- (c) What are equilibrium modifiers? [2 Mark]
- (d) Mention two disadvantages of using equilibrium modifiers.[2 Marks]

6.

- (a) Discuss with the help of neat flowsheets the production of H₂SO₄ and elemental sulphur from smelter flue gases. [11 Marks]
- (b) Describe with diagrams how the following gas cleaning equipments operate: [9 Marks]
- (ii) electrostatic precipitators,
(iii) scrubbers, and
(iv) Bag Houses

=====

Given:

$$n_{\text{O}}^{\text{B}} + \left(\frac{\text{O}}{\text{Fe}}\right)^{\text{X}} = n_{\text{C}}^{\text{A}} \left(\frac{\text{O}}{\text{C}}\right)^{\text{g}}$$

$$n_{\text{O}}^{\text{B}} + \left(\frac{\text{O}}{\text{Fe}}\right)^{\text{X}} - \frac{\text{D}}{283000} = n_{\text{C}}^{\text{A}} \frac{172000}{283000}$$

$$X_{\text{CO}_2}^{\text{g}} = \left(\frac{\text{O}}{\text{C}}\right)^{\text{g}} - 1 \quad \text{and} \quad X_{\text{CO}}^{\text{g}} = 2 - \left(\frac{\text{O}}{\text{C}}\right)^{\text{g}}$$

DATA

Atomic Weights

Fe = 55.845; S = 32.06; O=15.999; C = 12.011

END OF EXAMINATION IN MET 5259

GOOD LUCK

THE UNIVERSITY OF ZAMBIA

UNIVERSITY EXAMINATIONS – AUGUST/SEPTEMBER 2017

MET 5259 – Special Topics in Extractive Metallurgy

ANSWER: Five Questions.

TIME: Three Hours

1.

- a) Give three reasons why metal recycling is important. [3 Marks]
b) Describe the methods of recycling of any two of the following metals:

- (i) Copper
- (ii) lead and
- (iii) zinc

[8 Marks]

- c) Describe the metallurgical extraction process (including furnace used and reactions involved) as applied to any **one** of the following metals: [5 Marks]

- i. Nickel
- ii. Lead
- iii. Zinc
- iv. Aluminium

- d) Describe the environmental aspects associated with the extraction of the metals you have chosen in (b). [4 Marks]

2.

- a) What are the three main objectives of solvent extraction? [3 Marks]
b) Mention five properties a successful copper extractant must have. [5 Marks]
c) What is the essential difference between electrorefining and electrowinning? [2 Marks]
d) What are the two main sources of impurities in cathodes obtained through electrowinning? [2 Marks]
e) Why are electrowon cathodes lighter than electro-refining cathodes? [2 Marks]
f) Why are cathode current efficiencies in electrowinning plants rather low? [3 Marks]

- g) The most difficult problem in copper-SX circuits is the crud formation. What is crud and how could it be minimised in practice? [3 Marks]

3.

A lead sinter to be smelted in a blast furnace analyses 8% CaO, 25% SiO₂, and 15% Fe. In smelting this sinter, a slag is desired with CaO, FeO and SiO₂ in the proportions:

$$\text{CaO} : \text{FeO} : \text{SiO}_2 = 4 : 6 : 7$$

To obtain this slag, iron ore and limestone of the following analyses are added to the charge:

material	Wt% Fe	Wt% CaO	Wt% SiO ₂
Iron ore	45.0	0.5	15.0
limestone	2.0	46.0	8.0

In addition, coke is to be added to the charge as a fuel in an amount equal to 12 percent of the weight of (sinter + iron ore + limestone). The coke contains 2.5% Fe₂O₃ and 12% SiO₂.

Assuming that all the lime, iron and silica enter the slag as CaO, FeO and SiO₂, calculate the weights of iron ore, limestone and coke to be used per metric tonne of lead sinter.

[20 Marks]

Question 4

(a) Discuss with the help of neat flowsheets the production of H₂SO₄ and elemental sulphur from smelter flue gases.

(b) Describe with diagrams how the following gas cleaning equipments operate:

- (i) electrostatic precipitators,
- (ii) scrubbers, and
- (iii) Bag Houses

[20 Marks]

5.

(a) Calculate the coke requirement and top gas analysis for a blast furnace which is operating according to the data given in the following Table:

Item	Specification	Quantity		Model variable Kg moles/kg mole Fe
		Kg /t Fe	Kg moles/t Fe	
Fe	-	1000	17.9	
Iron Oxide	Fe ₂ O ₃			$\left(\frac{O}{Fe}\right)^x = \frac{3}{2}$
Oxygen in air blast	1350 NM ³ air /t Fe			$n_o^B = 1.41$
Heat demand				D = 486000 kJ/kg mole Fe
Pig iron	5 % C			$\left(\frac{C}{Fe}\right)^m = 0.25$
Active carbon				$n_c^A = 1.96$
Input carbon from all sources				$n_c^I = 2.21$

(b) The exit gas composition from a Fe₂O₃ charged furnace is 24 vol% CO, 22 vol% CO₂ and 54 vol% N₂. The air blast is 1400 m³/1000kg of product iron. The hot metal contains 5%C. Calculate:

- (i) Quantity of active carbon in kg/ton Fe.
- (ii) Total carbon in kg.

[20 Marks]

6.

- a) Describe the operation of the Isasmelt matte smelting furnace with the aid of a neat diagram. Outline four benefits provided by this technology. [8 Marks]
- b) Two copper sulphide concentrates, named X and Y, destined for matte smelting are blended in mass ratio of 3 parts X to 2 Parts Y. If the concentrates analyse (gangue oxide composition only) as shown below, calculate how much silica flux (with 80% SiO₂) needs to be added per tonne of the concentrate blend so that the normalized slag composition is: 59% SiO₂, 31% CaO, and 10% Al₂O₃. State any assumptions you make. [12 marks]

Concentrate	Gangue oxide composition			
	% Al ₂ O ₃	%MgO	% SiO ₂	% CaO
X	6.52	0.73	40.1	19.2
Y	8.50	12.81	28.1	13.95

=====END OF EXAM IN MET 5259=====

DATA

Atomic Weights

Fe = 56; S = 32; O = 16; Cu = 64; Ca = 40; Si = 28; C =12; Al = 27; Mg = 24

Given:

$$n_O^B + \left(\frac{O}{Fe}\right)^X = n_C^A \left(\frac{O}{C}\right)^g$$

$$n_O^B + \left(\frac{O}{Fe}\right)^X - \frac{D}{283000} = n_C^A \frac{172000}{283000}$$

$$X_{CO_2}^g = \left(\frac{O}{C}\right)^g - 1 \quad \text{and} \quad X_{CO}^g = 2 - \left(\frac{O}{C}\right)^g$$

THE UNIVERSITY OF ZAMBIA

UNIVERSITY EXAMINATIONS – SEPTEMBER 2016

MET5329

MATERIALS PERFORMANCE

TIME: THREE HOURS

ANSWER: ALL the questions in Section A and THREE questions in Section B

SECTION A

1. What materials would you select for the following applications and why?
 - (a) Dental amalgam
 - (b) Automotive exhaust system
 - (c) Gas turbine parts
 - (d) Wire brush

2. Discuss the validity of the following statements, in each case explaining your reasoning.
 - (a) The presence of cracks contributes to the very significant difference between theoretical, and actual fracture strength of materials.
 - (b) There is no such a thing as absolute brittle or ductile fracture.
 - (c) Non-ferrous alloys have a pronounced yield point on their stress-strain curve.
 - (d) During stress corrosion cracking, there is actually very little overall corrosion taking place.

SECTION B

3.
 - (a) Distinguish between endurance limit and fatigue limit.
 - (b) In which materials would you expect to observe a fatigue limit on the S-N curve and why?
 - (c) Draw the Goodman line for a steel whose ultimate stress is 1,250 MPa and whose fatigue limit (assuming completely reversed loading) is 400 MPa.
 - (d) If the steel in part (c) is loaded sinusoidally with an alternating stress $\sigma_a = 150$ MPa, what is the maximum stress that can be applied to the specimen without it failing if the Goodman line is taken as valid? The Goodman equation is

$$\sigma_a = \sigma_e \left\{ 1 - \left(\frac{\sigma_m}{\sigma_u} \right) \right\}$$

where σ_a = alternating stress, σ_e = fatigue limit, σ_m = mean stress and σ_u = ultimate stress

4.
 - (a) What is the phenomenon of yielding?
 - (b) For materials that show the upper and lower yield points, such as low C steels, which one of these two yield points would you use in the design of a structure? Justify your answer.
 - (c) A metal specimen with an initial diameter of 8 mm and an initial gauge length of 38 mm supports a maximum tensile load of 35,600 N, which occurs when the diameter is 6 mm and the gauge length is 55 mm. Find the engineering stress and strain at ultimate.
 - (d) What is the true strain at ultimate for the specimen in part (c)?

5.
 - (a) What is fatigue fracture?
 - (b) List three main factors responsible for fatigue fracture.

- (c) Miner's law is shown below. Describe how this law can be used to predict the chances of fatigue failure for a structure subjected to varying stresses.

$$\sum \frac{n_i}{N_i} = 1 \text{ or some other constant } \simeq 1$$

- (d) One form of the Paris equation is

$$\frac{da}{dN} = 5.01 \times 10^{-12} (\Delta K)^{3.1}$$

In a particular study, data for the range of da/dN from 10^{-9} to 3×10^{-6} m/cycle has been collected. Assume that the stress ratio in a fatigue cycle equals zero and that $\sigma_{\max} - \sigma_{\min} = 400$ MPa. If

$$\Delta K = \Delta \sigma \sqrt{\pi a}$$

- (i) Determine the crack length, a , when the growth rate is 10^{-9} m/cycle.
 (ii) Determine the crack length, a , when the growth rate is 3×10^{-6} m/cycle.

6. (a) Distinguish between the electromotive force (EMF) and galvanic series.
 (b) What is galvanic corrosion?
 (c) Describe a simple laboratory test that can be used to determine galvanic series.
 (d) Describe the cathodic protection of materials against corrosion.
 (e) Polarization curves (current vs potential) of iron in water are shown below.
 (i) What is the role of the indicated reactions on the corrosion of iron?
 (ii) On this diagram, what would you select as the corrosion current and potential and why?
 (iii) Discuss the possible ways of reducing corrosion rate, based on these polarization curves.

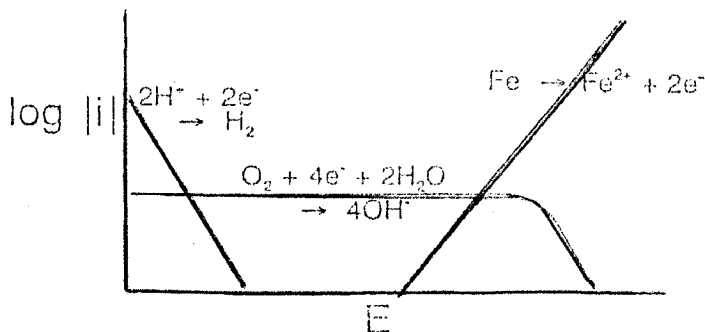

END OF EXAMINATION IN MET5329

Question	1	2	3	4	5	6
Points	12	12	25	25	25	25

THE UNIVERSITY OF ZAMBIA

UNIVERSITY EXAMINATIONS – AUGUST/SEPTEMBER 2017

MET5329

MATERIALS PERFORMANCE

TIME: THREE HOURS

ANSWER: ALL the questions in Section A and THREE questions in Section B

SECTION A

1. What materials would you select for the following applications and why?
 - (a) Fuse cap
 - (b) Solder for general applications
 - (c) Cylinder head
 - (d) Internal protection of a geyser against corrosion
2. Discuss the validity of the following statements, in each case explaining your reasoning.
 - (a) According to the Griffith criterion, a crack can propagate in a structure without the apparent presence of stress.
 - (b) Low transition temperature steels are the most expensive.
 - (c) Presence of notches does not affect the ductile to brittle transition.
 - (d) Ductility is a desirable property in engineering materials.

SECTION B

3. (a) What is fracture toughness?
 - (b) The scanning electron microscope fractograph below is from mild steel. At which locations in this fractograph (A, B or C) is there brittle or ductile fracture and why?

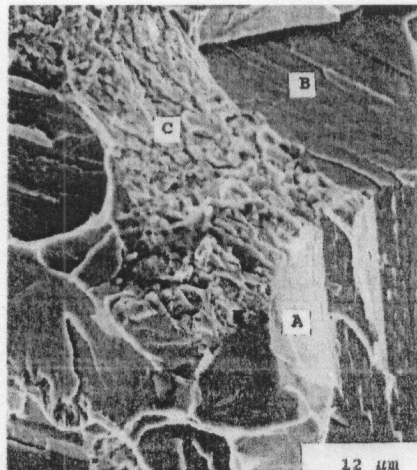

(C.C. Chama, *Journal of Materials Engineering and Performance*, 4:70-81 (1995))

- (c) In class, it was shown that

$$K_I = f(\sigma, a, Q)$$

where K_I = stress intensity factor, σ = applied stress, a = crack size and Q = crack geometry/loading configuration. Explain the effect of each one of these variables (σ , a , Q) on the fracture toughness.

- (d) A large thick plate of steel is examined by x-ray methods and found to contain no detectable cracks. The equipment can detect a single edge-crack of size $a = 5$ mm or greater. The steel has a fracture toughness K_{IC} of $40 \text{ MN m}^{-3/2}$ and a yield strength of 500 MN m^{-2} .

$$K_I = \sigma\sqrt{\pi a}$$

- What is the stress at which fracture would occur?
- Assuming that the plate contains cracks on the limit of detection, determine whether the plate will undergo general yield or will fail by fast fracture before general yielding occurs.

- 4.(a) Indicate briefly how the following would affect fatigue life

- a good surface finish
- a sharp change in section
- a significant mean tensile stress
- a corrosive atmosphere

- (b) In class it was stated that for engineering components, the ASME has recommended that a curve which is less than the experimental curve by two orders of magnitude for stress or twenty for number of cycles to failure should be used in design (examples of such curves are shown below). Justify why this should be so.

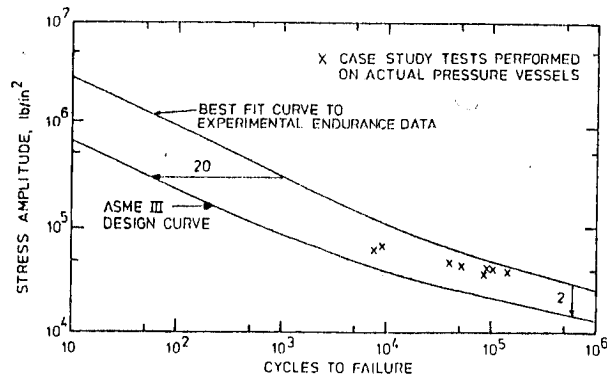

- (c) An aluminium alloy for an airframe component was tested in the laboratory under an applied stress which varied sinusoidally with time about a mean of zero. The alloy failed under a stress range $\Delta\sigma$ of 280 MN m^{-2} after 10^5 cycles; under a stress range of 200 MN m^{-2} , the alloy failed after 10^7 cycles. Assume that the fatigue behaviour of the alloy can be represented by

$$\Delta\sigma(N_f)^a = C$$

where a and C are material constants. Find the number of cycles to failure N_f for a component subjected to a stress range of 150 MN m^{-2} .

- 5.(a) Why are fine-grained materials more likely to undergo creep as compared to those that are coarse-grained?
- (b) With the aid of an appropriate sketch, illustrate the effects of temperature and stress on creep.
- (c) Describe the processes taking place during the secondary stage of creep.
- (d) The creep rate in the secondary stage can be described by the equation shown below.

$$\dot{\epsilon}_{ss} = A\sigma^n \exp - \left(\frac{Q}{RT} \right)$$

where $\dot{\epsilon}_{ss}$ = secondary creep rate, n = creep exponent, Q = activation energy, A = constant and σ = applied mean stress. Describe how you would go about determining the activation energy for creep by using this equation.

6. (a) Outline the costs associated with the occurrence of corrosion
- (b) In the prevention of corrosion, organic coatings such as paints and varnishes are commonly used. State four major advantages of paints as compared to other coatings.
- (c) In galvanized steel, explain why zinc will continually give protection against corrosion even if the steel is exposed.
- (d) In class it was stated that materials with the active-passive transition can be prevented from undergoing further corrosion even in very aggressive environments. What is the active-passive transition? Give an example of a material which exhibits this transition.
- (e) Describe, with the aid of an appropriate sketch, the process of hydrogen attack in steels i.e. interaction of hydrogen with grain boundary particles such as Fe_3C .

END OF EXAMINATION IN MET5329

Question	1	2	3	4	5	6
Points	12	12	25	25	25	25

THE UNIVERSITY OF ZAMBIA

UNIVERSITY EXAMINATIONS –SEPTEMBER 2016

MET5349

FOUNDRY TECHNOLOGY

TIME: THREE HOURS

ANSWER: ALL the Questions in Section A and THREE Questions in Section B

SECTION A

1. Write brief notes on the following:

- (a) Undercooling
- (b) Planar interface growth
- (c) Investment Casting
- (d) Die casting

2. (a) Describe the uses of the following foundry materials

- (i) sands
- (ii) clays
- (iii) binders
- (iv) water

(b) Why is it essential for a foundry sand to have the following properties?

- (i) permeability
- (ii) thermal stability
- (iii) refractoriness

SECTION B

3. (a) During solidification

$$K = \frac{X_S}{X_L}$$

(i) How does solute composition of the solid and remaining liquid vary during solidification when $K < 1$?

(ii) How does solute composition of the solid and remaining liquid vary during solidification when $K > 1$?

(b) The composition profile at T_E (eutectic temperature) and below during solidification in a single phase alloy, of initial composition X_0 , with no diffusion in the solid but perfect mixing in the liquid is shown below.

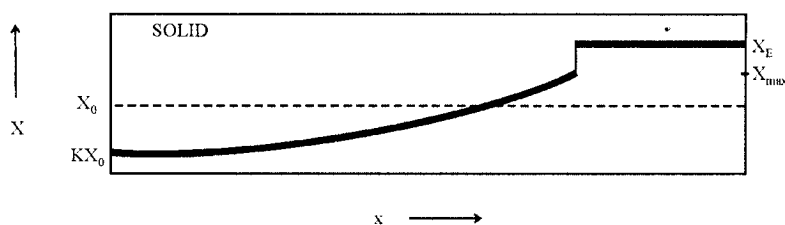

- (i) Discuss how this composition profile develops.
 (ii) If the solute balance is

$$(X_L - X_S)df_S = (1 - f_S)dX_L$$

Show that

$$X_S = KX_0(1 - f_S)^{(K-1)}$$

$$X_L = X_0 f_L^{(K-1)}$$

4. (a) In the design of a gating system, what is the “choke area” and why should its dimensions be known first before those of other gating system elements?
 (b) A horizontal gating system is shown below. What are the two main functions of a horizontal gating system?

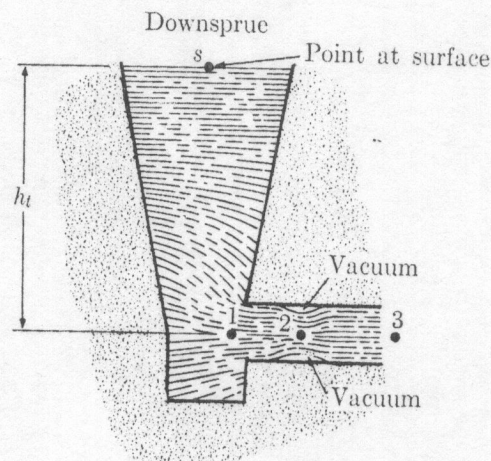

- (c) What is the “vena contracta” in the gating system shown above?
 (d) Using Bernoulli's equation

$$h + \frac{v^2}{2g} + \frac{P}{\rho g} = \text{Constant}$$

- (i) Determine the gas pressure across section 2
 (ii) Will gas get aspirated into the metal stream across section 2? If so, how is this problem overcome?
5. (a) List three differences between solidification in pure metals and alloys.
 (b) The figure below shows a solid with primary, secondary and tertiary dendrite arms. Describe in detail how these dendrite arms develop during solidification.

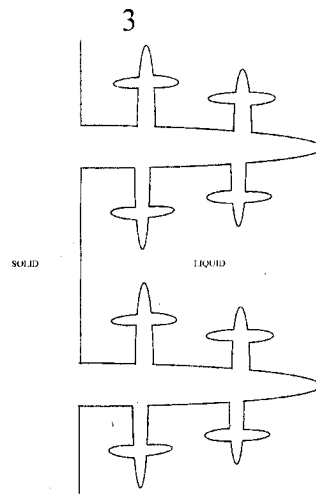

(c) The dendrite arm spacing (DAS) is dependent on the cooling rate, ϵ , by an equation of the form

$$DAS = k\epsilon^{-n}$$

where $k = \text{constant}$. Suppose for Al-4.9% Cu, DAS was measured as 100 and 10 μm at the cooling rates of 0.1 and 60 K/s, respectively.

- (i) Determine k and n for the alloy
 - (ii) What cooling rate is necessary to reduce the arm spacing to 1 μm ?
6. (a) Discuss the advantage and disadvantage that may arise due to the presence of nitrogen in ferrous alloys during casting.
- (b) Determine the maximum amount of nitrogen soluble at a pressure of 1 atm N_2 in a type 308 stainless steel containing 0.4 %C, 2.0 % Mn, 2%Si, 20 %Cr and 10 %Ni at 1600°C. The appropriate data is shown in the figures below. HINT: Determine $\log f_N$ for each element using Figure (a); $\log f_N$ in Figure (b) is the sum.
- (c) What would happen if the amount of nitrogen in part (b) is exceeded?
- (d) What would happen if the amount of nitrogen in the melt is less than that in part (b)?

END OF EXAMINATION IN MET5349

Question	1	2	3	4	5	6
Points	12	12	25	25	25	25

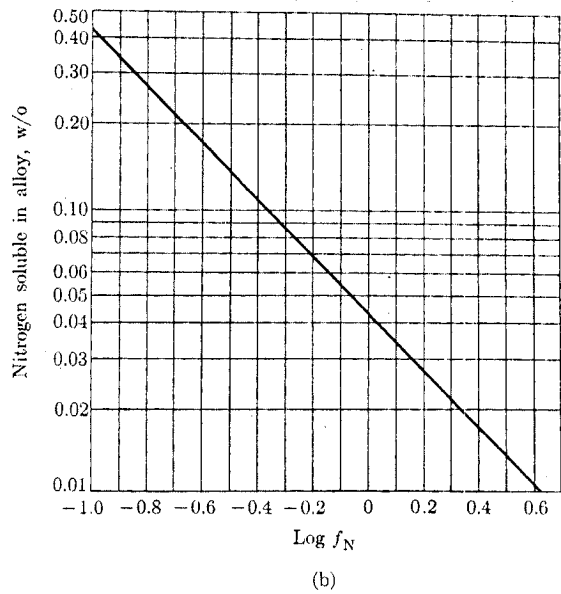
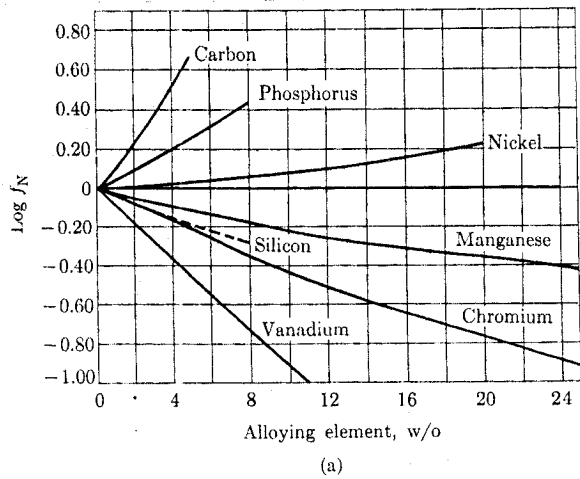

(a) Activity coefficients of nitrogen at 1600°C (2912°F) as a function of alloy content. Graph is used to compute $\log f_N$ in an alloy steel. (b) Chart for converting $\log f_N$ into w/o nitrogen soluble in an alloy at 1600°C (2912°F), under a pressure of 1 atm N. $\log f_N$ was determined from Fig. 10-1.

THE UNIVERSITY OF ZAMBIA

UNIVERSITY EXAMINATIONS –AUGUST/SEPTEMBER 2017

MET5349

FOUNDRY TECHNOLOGY

TIME: THREE HOURS

ANSWER: ALL the Questions in Section A and THREE Questions in Section B

SECTION A

1. (a) What are the main disadvantages of wood as a pattern material?
(b) Which are the alternatives to wooden patterns?
(c) Why is it essential at times to have a pattern that is oversize with respect to the desired casting product?

2. (a) Why is it essential for a foundry sand to have the following properties?
 - (i) flowability
 - (ii) collapsibility
 - (iii) reusability
(b) With the aid of appropriate sketches and the exercise at the UNZA foundry, briefly describe the processes of sand casting.

SECTION B

3. (a) Distinguish between homogeneous and heterogeneous nucleation.
(b) The variation of free energy with nucleus size is shown below. What are the parameters ΔG^* and r^* ?

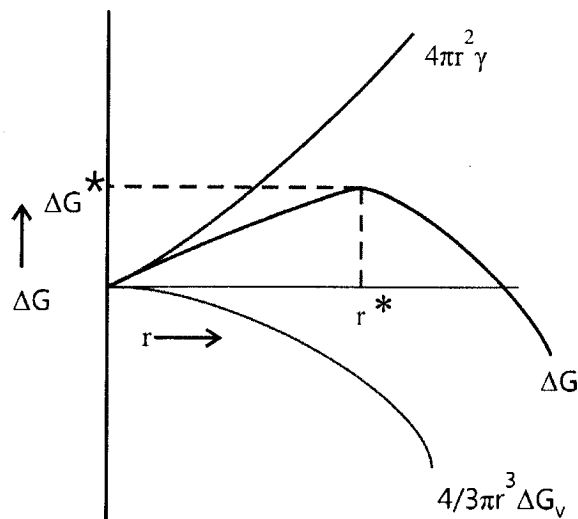

- (c) Explain their significance of the parameters ΔG^* and r^* during solidification.
- (d) How does under cooling affect the parameters ΔG^* and r^* during solidification?
4. (a) What is the primary function of a riser and what is its optimum shape?
- (b) Why is the optimum riser shape not employed in foundry practice?
- (c) How are the limitations in part (b) of the optimum riser shape accounted for in most risers?
- (d) Determine the dimensions of a riser (i.e. diameter and height) that can be used to produce a casting with length, width and thickness of 10, 5 and 2 in, respectively. The appropriate risering curves are shown below.

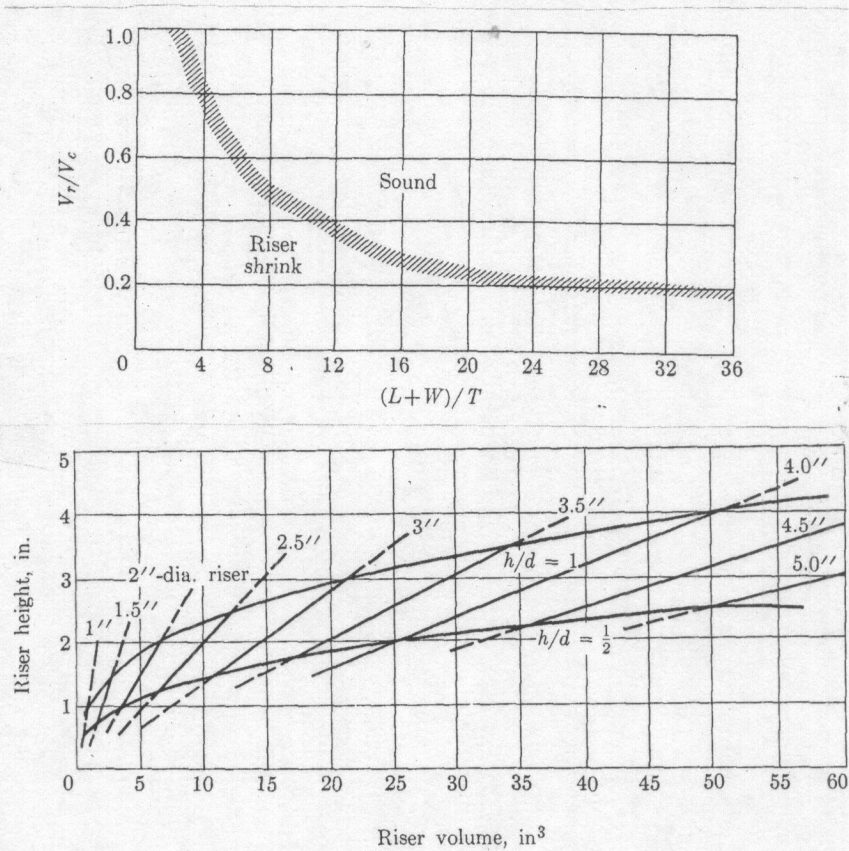

5. (a) Investment casting has been around for over 6,000 years. What were the earliest products of this process?
- (b) List seven of the advantages of investment casting
- (c) List four of the disadvantages of investment casting
- (d) Describe in detail the processes involved in investment casting

6. (a) Discuss what advantage and disadvantage would arise by the presence of nitrogen in steel.
 (b) What is segregation as applied to castings and what would you expect to be its effect on properties?
 (c) Describe how you would utilize the principle of segregation to refine a semi-conductor.
 (d) The diagram below shows various inclusions in steel. On the basis of the levels of impurities observed, justify the need to have a properly designed gating system for feeding a mould cavity with molten metal.

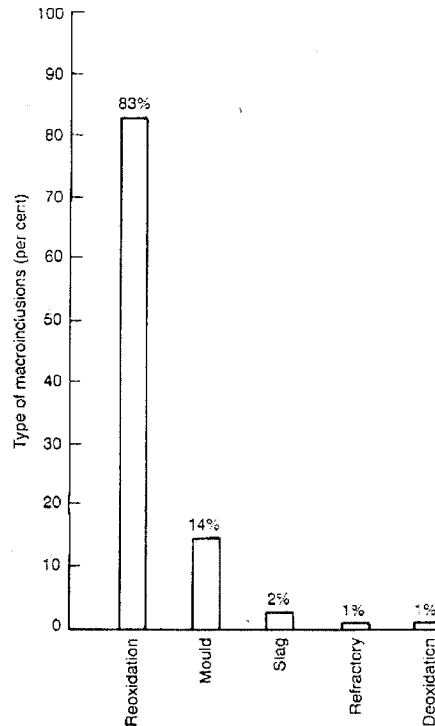

(J.M. Svoboda, R.W. Monroe, C.E. Bates and J. Griffin, *TAFS*, vol. 95 (1987) 187-202)

END OF EXAMINATION IN MET5349

Question	1	2	3	4	5	6
Points	12	12	25	25	25	25

THE UNIVERSITY OF ZAMBIA

UNIVERSITY EXAMINATIONS - SEPTEMBER 2016

MET 5469

PROCESS DESIGN

TIME : THREE HOURS
ANSWER : FIVE questions

Additional information is provided with the examination paper.
Where applicable, all calculations are to be done correct to three decimal places.

1. (a) Briefly discuss the significance of design variables in process design. (4 marks)
- (b) A coal containing 80 mass percent total carbon and 5 mass percent unoxidised hydrogen is burned in dry air. The rest of the coal is solid inert. The amount of air used is 30 percent more than that theoretically required for the complete combustion. Calculate, **per kg of coal**, the number of kmoles of air supplied and the number of kmoles of stack gas leaving the furnace assuming this gas contains no CO. Atomic masses: C, 12; O, 16; H, 1; N, 14. (16 marks)

2. (a) Two important stages of a plant design are raw material storage and feed preparation. Discuss each of these stages. (5 marks)
- (b) If pure H₂ is burned completely with 32% excess air, what is the flue gas analysis? (5 marks)
- (c) In the manufacture of sulphuric acid from pyrite, the following two reactions occur simultaneously when the pyrite is burned in air:

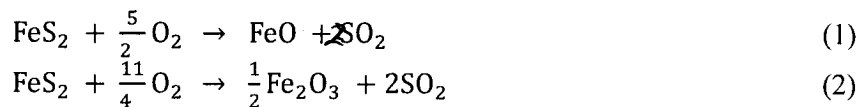

From such a burner, the flue gases are analysed as 10.2 mole percent SO₂, 7.8 mole percent O₂ and 82.0 mole percent N₂.

(i) In what ratio do reactions 1 and 2 take place?

(ii) How much excess air is fed to the burner if all the pyrites are burned?

Use 100 kmols of flue gases as a **basis**. **Start with n kmols of pyrite, a fraction x of which reacts by reaction 1.** (10 marks)

3. (a) Distinguish between external and internal constraints in process design. Comment on one of each. (5 marks)
- (b) In a wood drier, the hot air must contain at least 2 weight per cent water to prevent the wood from drying too rapidly and splitting. The original fresh air fed contains 1 wt% water. Wood is dried from 20 wt% water to 5 wt% water. The air leaving the drier contains 4 weight percent water. Calculate the amount of wet air that must be

returned to the drier if one tonne (1000 kg) per hour of wet wood is dried. The flow diagram is as below:

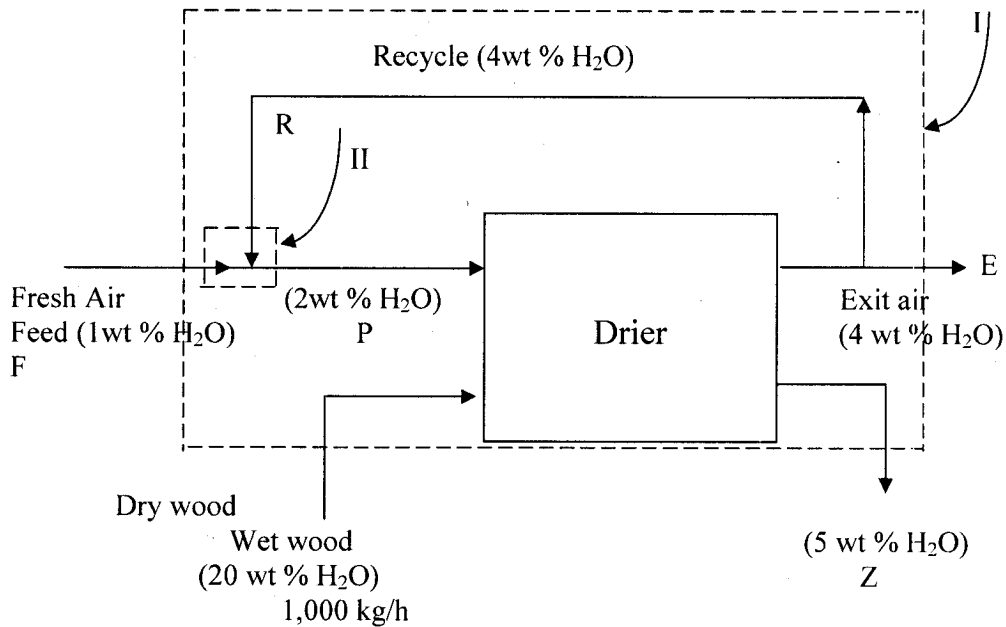

(15marks)

4. (a) Briefly comment on regenerative heat exchangers.

(3 marks)

(b) For a system with a combination of n inlets and outlets, a general statement of the First Law is

$$dE' = \delta q - \delta w + \sum_i^n \delta m_i \left(u_i + P_i v_i + \frac{\bar{v}_i^2}{2} + g z_i \right)$$

From the above equation, derive the equation $dH' = \delta q$.

(4 marks)

(c) An electric melting furnace is used to melt copper scrap. The scrap is at an initial temperature of 25°C . It is claimed that the overall average power consumption of the furnace is 280 kWh per ton of copper melted. Calculate the amount of heat required assuming that the copper is not only melted but also heated to a final temperature of 1200°C . Estimate the thermal efficiency of this furnace in percent.

Melting point of copper: 1083°C

Heat of fusion of copper: 12,970 J/mol

C_p for Cu(l) = $22.64 + 6.28 \times 10^{-3} T$ J/mol.K

C_p for Cu(s) = 31.38 J/mole.K

Atomic weight of Cu : 63.55

1 Wh : 3600 J

(13marks)

5. (a) Comment on three categories of fouling in heat exchanger design.

(4 marks)

(b) Determine the overall heat transfer coefficient U_o based on the outer surface of a brass tube with $D_i = 2.5$ cm and $D_o = 3.34$ cm [$k = 110$ W/(m⁰C)] for the following conditions: The inside and outside heat transfer coefficients are, respectively, $h_i = 1200$ and $h_o = 2000$ W/(m².⁰C); the fouling factors for the inside and outside surfaces are $h_{id} = h_{od} = 5500$ W/(m².⁰C)

$$U_o = \frac{1}{A_o \left[\frac{1}{A_o h_o} + \frac{1}{A_o h_{od}} + \frac{\ln(r_o / r_i)}{2\pi k_w L} + \frac{1}{A_i h_{id}} + \frac{1}{A_i h_i} \right]}$$

(10marks)

(c) A counterflow heat exchanger flow arrangement is to be designed to heat 2.0 kg/s of pressurised water [$c_p = 4.2$ kJ/kg.⁰C] from 40⁰C to 120⁰C flowing on the tube side, by using hot water [$c_p = 4.66$ kJ/kg.⁰C] entering the shell side at 300⁰C with a flow rate of 1.03 kg/s. The overall heat transfer coefficient is $U = 1250$ W/(m².⁰C). Calculate the heat transfer area required.

(6 marks)

6. (a) It is desired to warm an oil of specific heat 2.0 kJ/(kg)(K) from 300 to 325 K by passing it through a tubular heat exchanger with metal tubes of inner diameter 10 mm. Water of specific heat 4.17 kJ/(kg)(K) flows along the outside of the tubes with inlet temperature 372 and outlet temperature 350 K.

The overall heat transfer coefficient from the water to oil, based on the inside area of the tubes, may be assumed constant at 230 W/(m²)(K) and 75 g/s of oil is passed through each tube. The oil is to make two passes through the exchanger. The water makes one pass along the outside of the tubes.

Calculate

- (i) the length of the tubes required,
- (ii) the water flow rate in kg/h.

(12 marks)

(b) A counterflow heat exchanger of heat transfer area $A = 14.0$ m² is to cool oil [$c_{ph} = 2000$ J/kg.⁰C] with water [$c_{pc} = 4170$ J/kg.⁰C]. The oil enters at 100⁰C and the flow rate is 2 kg/s while the water enters at 20⁰C with a flow rate of 0.48 kg/s. The overall heat transfer coefficient is 400 W/(m²)(⁰C). Calculate the exit temperature of the water and the heat load.

(8 marks)

END OF EXAMINATION IN MET 5469

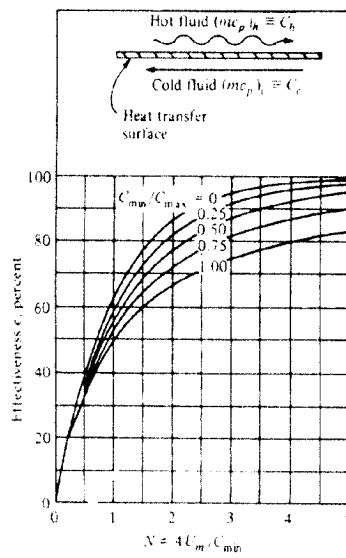
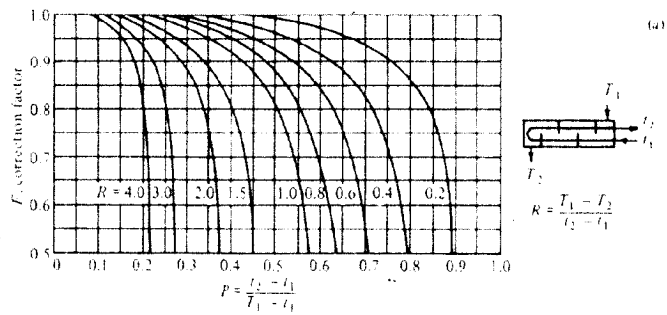

Figure 11-18 Effectiveness for a counterflow heat exchanger. (From Kays and London [10].)

**MIN 5019 Geotechnical Engineering
Some Equations**

$$F.S = C.A + (W \cdot \cos \psi \rho - U - V \cdot \sin \psi \rho) \tan \theta$$

$$W \cdot \sin \psi \rho + V \cdot \cos \psi \rho$$

$$P = (1 - z/H) \cdot \operatorname{Cosec} \psi \rho$$

$$Q = [(1 - (z/H)^2) \cot \psi \rho - \cot \psi f] \sin \psi \rho$$

$$Q = [(1 - z/H)^2 \cos \psi \rho (\cot \psi \rho \cdot \tan \psi f - 1)]$$

$$R = \gamma_w / \gamma \cdot Z_w / Z \cdot Z / H$$

$$S = Z_w / Z \cdot Z / H \sin \psi \rho$$

$$A = (H - Z) \cdot \operatorname{Cosec} \psi \rho$$

$$U = 1/2 \gamma_w \cdot Z_w \cdot (H - Z) \cdot \operatorname{Cosec} \psi \rho$$

$$V = 1/2 \gamma_w \cdot Z_w^2$$

$$F = (2C / \gamma H \cdot \rho + (Q \cdot \cot \psi \rho - R(P + S)) \tan \Phi$$

$$Q + R \cdot S \cot \psi \rho$$

END OF EXAMINATION

THE UNIVERSITY OF ZAMBIA
SCHOOL OF MINES

UNIVERSITY EXAMINATION - AUGUST/SEPTEMBER 2017
MET 5469: PROCESS DESIGN

TIME : THREE HOURS
ANSWER : FIVE questions

Additional information is provided with the examination paper.
Where applicable, all calculations are to be done correct to three decimal places.

1. (a) Distinguish between external and internal constraints in process design. Comment on one of each. (4 marks)
 (b) Deduce the number of design variables and how they may be utilized for a stream separator, assuming all streams being liquid. (4 marks)
 (c) An annealing furnace uses a fuel oil containing 12.0 wt% H and 88.0 wt% C. It is proposed to fire this furnace with 25% excess air. If 10 wt% of the total carbon burns to CO only, calculate the flue gas analysis in mole %. Take 1 kg of fuel as a basis.
 Atomic masses: H, 1; C, 12; O, 16; N, 14. (12 marks)

2. The air used to burn S or FeS₂ in making sulphuric acid must first be dried. Passing it counter to a stream of concentrated H₂SO₄ flowing through a packed tower does this. The acid enters the tower at 93 weight percent and is diluted as it absorbs H₂O. Some 92.0 weight percent H₂SO₄ is withdrawn from the system as the acid recycles, and the acid concentration is returned to 93 weight percent by adding 99 weight percent H₂SO₄ as shown in the figure below.

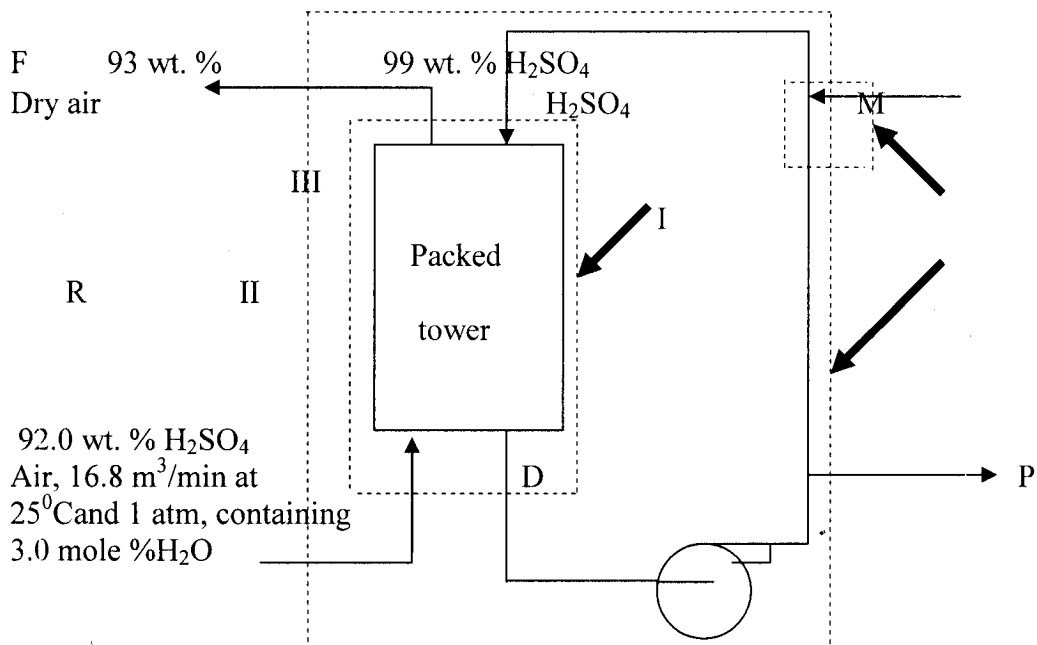

From these data and the flow diagram, calculate

- (a) the mass of 99 weight percent H₂SO₄ in kg added per hour,
 (b) the rate of flow of 93 weight percent H₂SO₄ entering the top of the column in kg/h.

R=8.314 J/mole.K

1 atm=1.013x10⁵ N/m². *Let water be component A and acid be component B.*

(20marks)

3. (a) For a system with a combination of n inlets and outlets, a general statement of the First Law is

$$dE' = \delta q - \delta w + \sum_{i=1}^n \delta m_i (u_i + P_i v_i + \bar{v}_i^2 / 2 + g z_i)$$

Derive the heat balance for a closed system from the above equation with work of expansion only and constant pressure.

(5 marks)

- (b) Producer gas at 25⁰C is burned with 10% excess air that is preheated to 1000⁰C. The composition of the producer gas is as follows:

Component	%	$\Delta H_c^0 \times 10^{-3}$ kJ/kmol
CO	28	-282.989
CO ₂	4	
H ₂	4	-241.826
CH ₄	2	-890.346
H ₂ O(g)	1	
N ₂	61	

The exit gas mixture leaves at 1500⁰C. The heat of combustion of H₂ is based upon producing H₂O(g). Calculate the kmols in the exit gas and the heat, in MJ, transferred for 100 kmols of producer gas.

Atomic weights: C,12; O,16; H,1; N,14.

The average specific heat capacity data are as follows:

Gas	c_p (in kJ/kmol. ⁰ C)
CO ₂	52.756
H ₂ O	41.030
O ₂	34.330
N ₂	32.240
Air	31.000

(15marks)

4. (a) Illustrate, with sketches, the temperature profiles of the fluids as a function of the distance along the flow path for a *parallel flow exchanger, counterflow exchanger*, and a *condenser*. The hot fluid in each case is on the shell side. Indicate the terminal temperatures on the sketches and the appropriate subscripts.

(5 marks)

(b) A gas stream of 500 kmol/h of CH₄ at 101.32 kPa and 373 K is burned in a furnace using air at 313 K. The combustion is complete and 50% excess air is used. The stack gas leaves the furnace at 700 K. **Calculate the heat removed in the furnace.** The combustion reaction for CH₄ at 298 K is as follows:

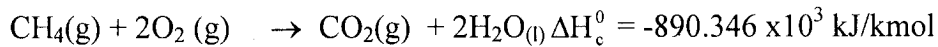

Latent heat of vaporisation of water at 100°C and 760 mm Hg is 40,683 kJ/kmol. The specific heat capacity of liquid water is 75.2 kJ/kg.K; the mean specific heat capacity of air is 29.1 kJ/kmol.K

The mean specific heat capacity data are as follows:

Gas	c_p (in kJ/kmol.K)
CO ₂	44.4
H ₂ O	35.1
O ₂	31.2
N ₂	29.9
Air	29.1

Hint: The water is initially produced as a liquid. Its enthalpy change should be calculated separately from the flue gas.

(15marks)

5. (a) What is a heat exchanger? Draw temperature profiles for two types of indirect contact heat exchangers.

(4 marks)

(b) Briefly describe a static type regenerative heat exchanger.

(3 marks)

(c) A heat exchanger is required to cool 3200 kg/h of benzene ($c_p = 1.74 \text{ kJ/kg } ^\circ\text{C}$) from 72°C to 42°C using cooling water ($c_p = 4.18 \text{ kJ/kg } ^\circ\text{C}$) at a flow rate of 2200 kg/h and 15°C inlet temperature. Calculate the area required for a 1-4 heat exchanger. The overall heat transfer coefficient may be taken as $0.28 \text{ kW/m}^2\text{ } ^\circ\text{C}$.

(13marks)

6. (a) Deduce the number of degrees of freedom (design variables) in the design of a cooler and indicate how these may be utilised.

(4 marks)

(b) A heat exchanger is to be designed to cool 8.7 kg/s of ethyl alcohol solution [$c_{pH} = 3.84 \text{ kJ/(kg. } ^\circ\text{C)}$]. This is to be done from 75°C to 45°C with cooling water [$c_{pC} = 4.18 \text{ kJ/(kg. } ^\circ\text{C)}$] entering the tube side at 15°C with a flow rate of 9.6 kg/s. The overall heat transfer coefficient based on the outer tube surface is $U_o = 500 \text{ W/(m}^2 \cdot ^\circ\text{C)}$. Calculate the heat transfer area for each of the following flow arrangements:

- (i) Parallel flow, shell and tube
- (ii) Counterflow, shell and tube
- (iii) Crossflow, both fluids unmixed.

(16marks)

END OF FINAL EXAMINATION IN MET 5469

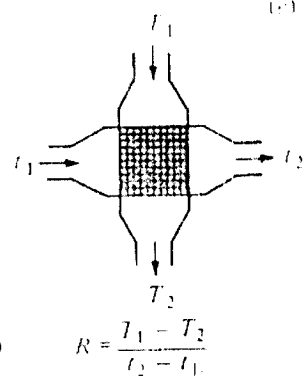
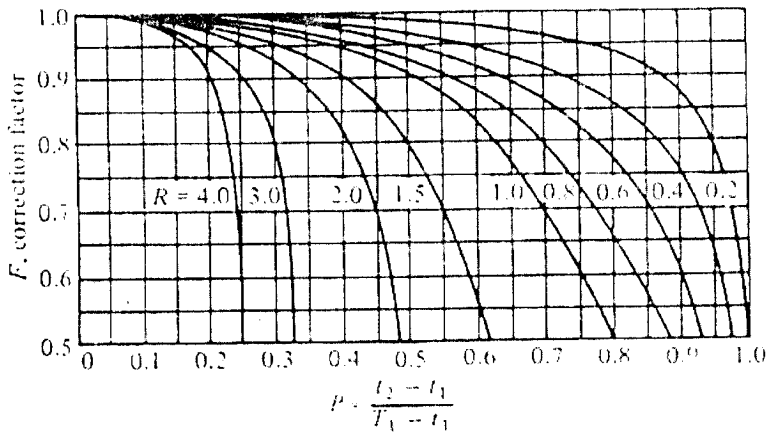
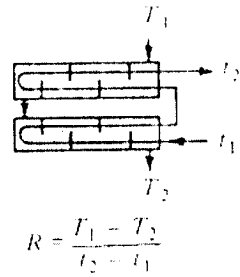
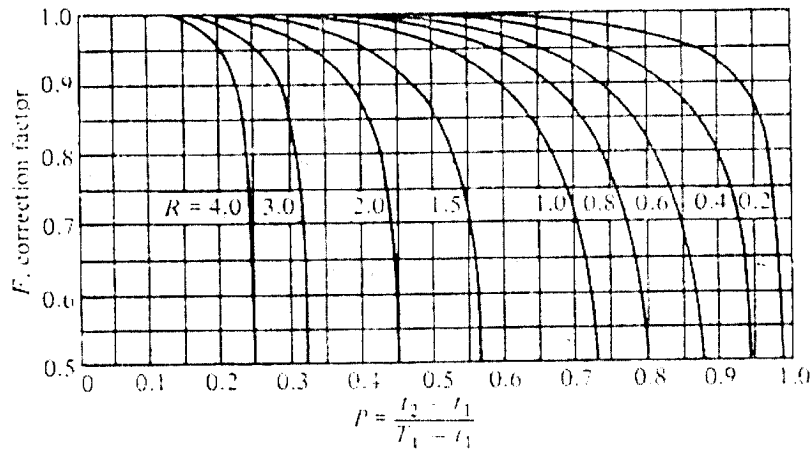
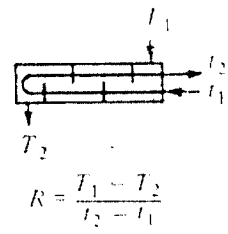
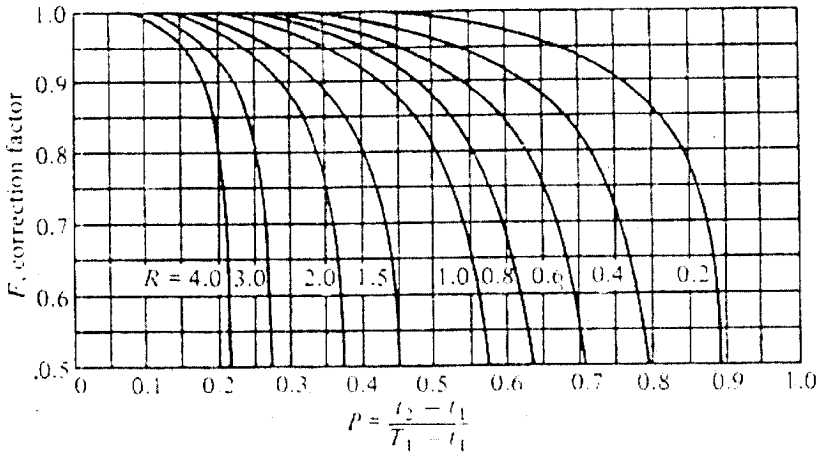

UNIVERSITY OF ZAMBIA
UNIVERSITY EXAMINATION – SEPTEMBER 2016

MIN 5019 – GEOTECHNICAL ENGINEERING

INSTRUCTIONS: ANSWER: ALL QUESTIONS
TIME: 3 HOURS

TOTAL MARKS: 100

Question 1

Wedge failure (shown in Figure below) is a problem that is wide spread and has been extensively discussed in numerous geotechnical literature. Discuss wedge failure under the following headings.

- | | |
|-------------------------------|-----------|
| (i). Typical Problems | [5 marks] |
| (ii). Critical Parameters | [5 marks] |
| (iii). Methods of analysis | [5 marks] |
| (iv). Acceptability Criteria. | [5 marks] |

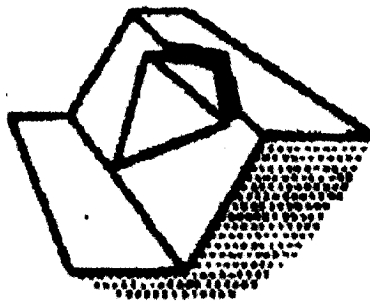

Question 2

Although a rock mechanics engineer may primarily be concerned with the stability of rock slopes, the engineer will occasionally be faced with a slope problem involving soft materials such as overburden soils, heavily jointed rock slopes or crushed stones. In such materials, failure occurs along a surface which approaches a circular shape. Discuss circular arc failure (see figure below) under the following headings:

- | | |
|------------------------------|-----------|
| (i). Typical Problems | [5 marks] |
| (ii). Critical Parameters | [5 marks] |
| (iii). Methods of Analysis | [5 marks] |
| (iv). Acceptability Criteria | [5 marks] |

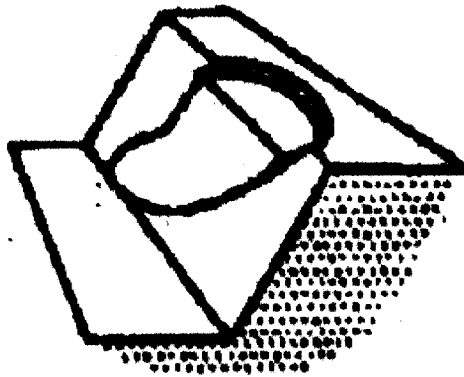

Question 3

Discuss the slope versus slope height relationships for the following different rock materials:

- (i). Intact material failure of horizontally bedded massive rock. **[5 marks]**
- (ii). Plane failure on through-going discontinuity surfaces such as sheet joints or bedding planes. **[5 marks]**
- (iii). Steeped failure surface in hard blocky rock masses such as limestone. **[5 marks]**
- (iv). Circular failure in soils and clays- typical in overburden slopes and in waste embankments. **[5 marks]**

Question 4

- (i). Describe in detail, with the aid of diagrams any two methods of measuring insitu permeability that you know. **[10 marks]**
- (ii). In a falling head permeability test, the initial head of 1.0m dropped to 0.35m in three (3) hours, the diameter of the standpipe being 5mm. The soil specimen was 200mm long and 100mm in diameter. Calculate the coefficient of permeability of the soil. **[10 marks]**

Question 5

A 50m high slope with a face angle of 60° is found to have a bedding plane running through it at a dip of 30° . A tension crack occurs 25m behind the crest of the slope and from an accurately drawn cross section of the slope, the tension crack is found to have a depth of 20m (refer to figures below).

The unit weight of the rock is $\gamma = 30\text{kN/m}^3$ and that of the water $\gamma_w = 9.81\text{kN/m}^3$. Assuming that the cohesive strength of the bedding plane $C = 50.50\text{kN/m}^2$ and the friction angle (ϕ) is $= 30^\circ$:

- (i). Find the influence of the water level Z_w upon the Factor of Safety of the slope. [15 marks]
- (ii). Comment on your findings. [5 marks]

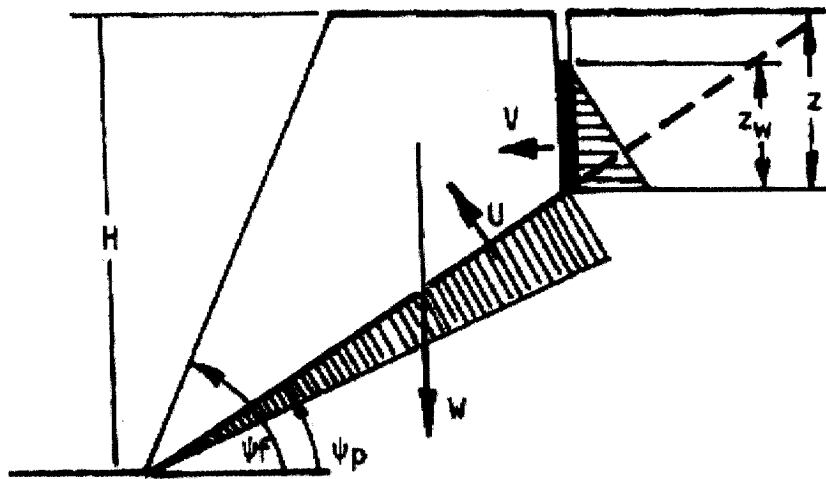
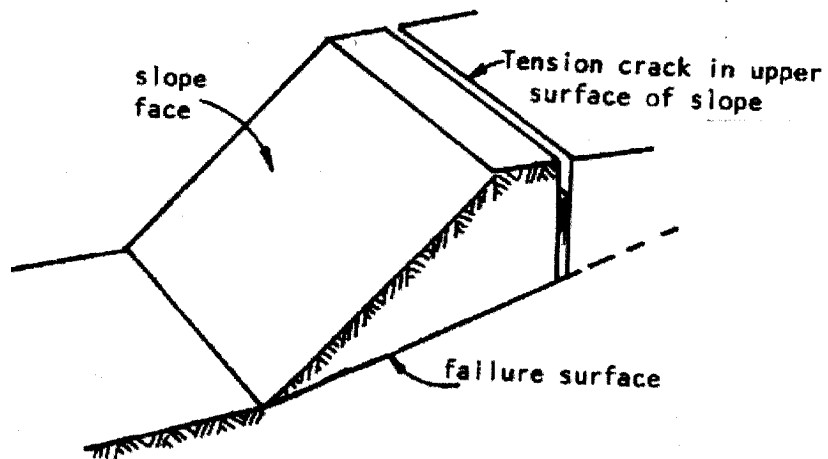

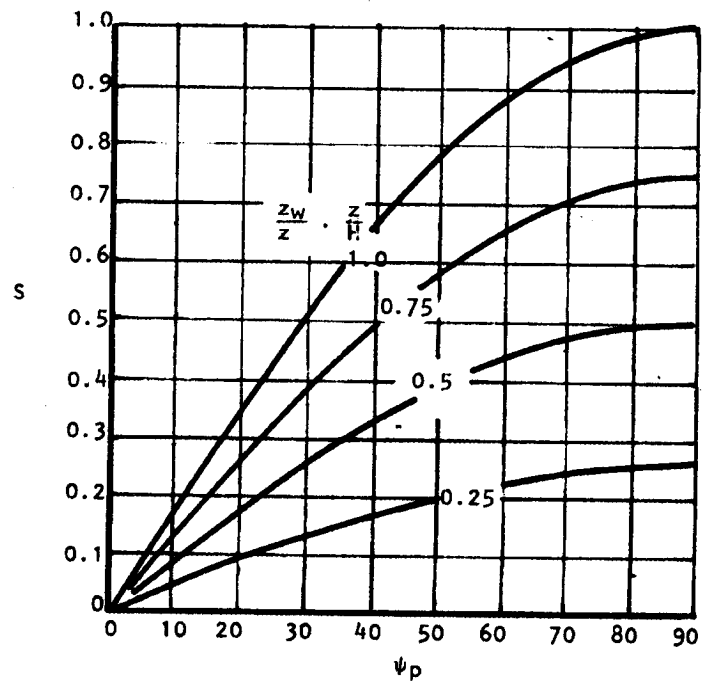
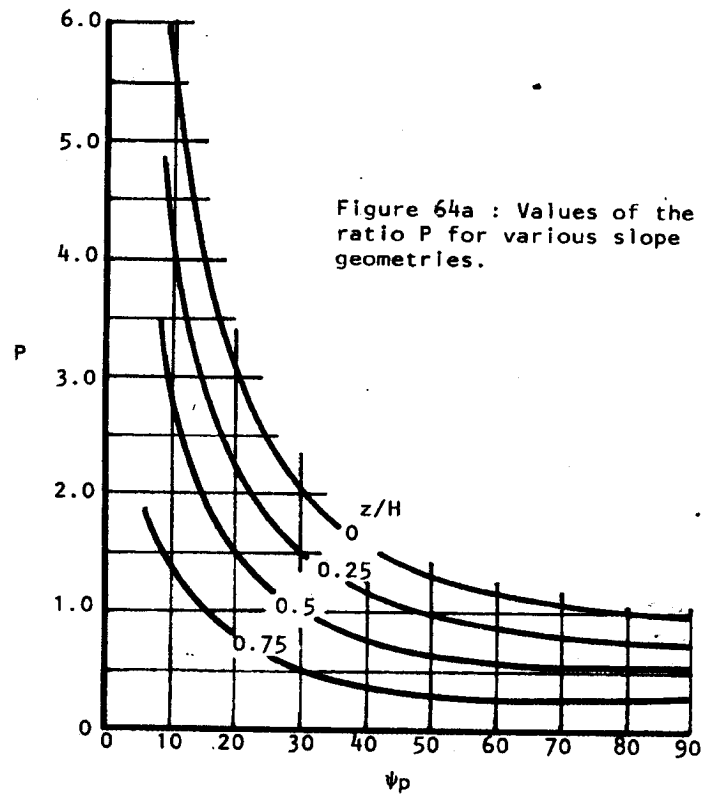
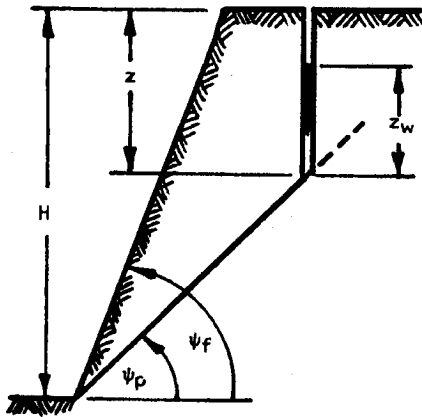

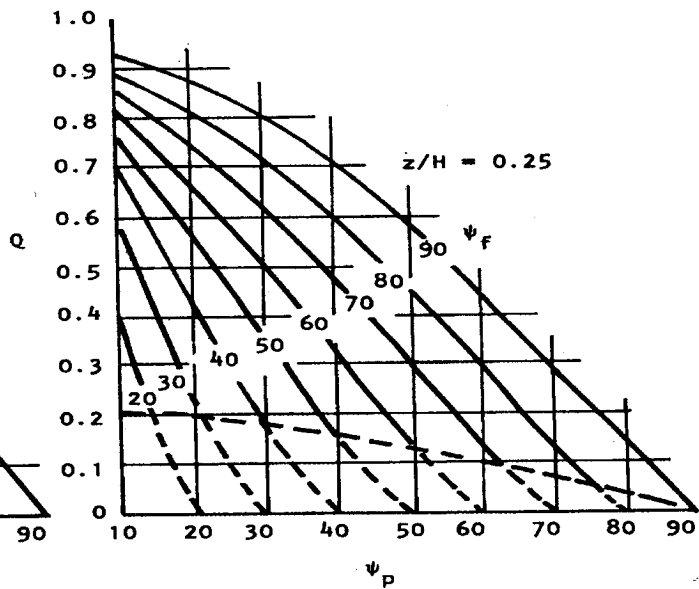
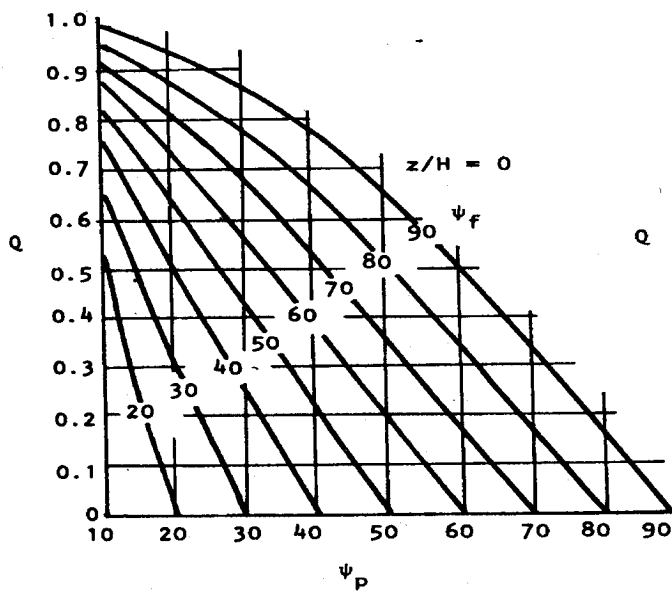

Note:
Dashed lines refer to tension crack
in slope face.

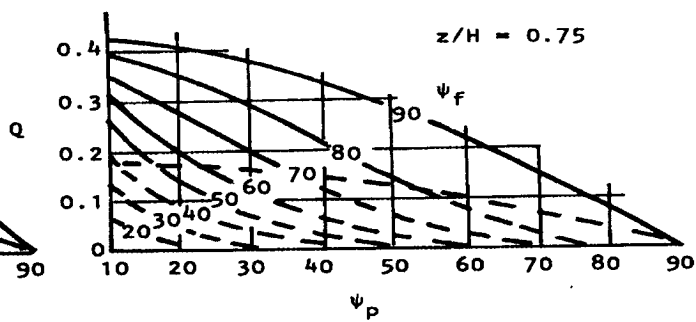
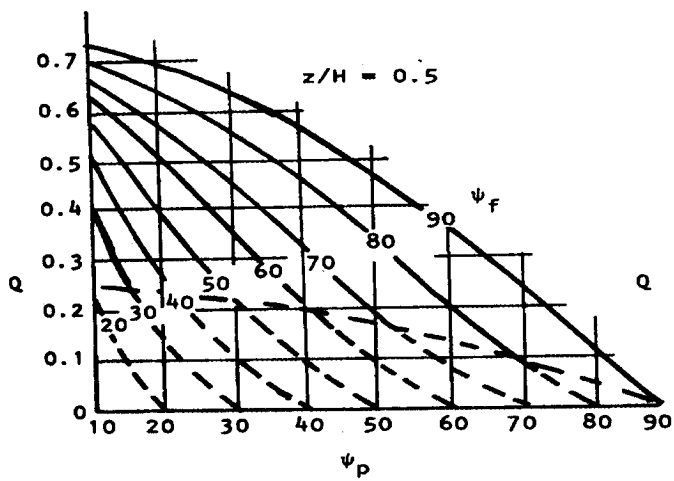

UNIVERSITY OF ZAMBIA

UNIVERSITY EXAMINATIONS – AUG / SEPT 2017

MIN 5019 – GEOTECHNICAL ENGINEERING

TIME: THREE (3) HOURS

Total Marks 100

INSTRUCTIONS: ANSWER ALL QUESTIONS

Question One

Toppling failures in hard rock slopes have only been recently described in literature during the past few years. One of the the earliests references is by Muller who suggested that block rotation or toppling may have been a contributory factor in the failure of the north face of the Vajont slide in Italy.

With reference to Figure 1, discuss in detail vertically jointed rock slopes in association with the following headings:

- (a) Typical problems (5 marks)
- (b) Critical parameters (5 marks)
- (c) Analysis Methods (5 marks)
- (d) Acceptability Criteria. (5 marks)

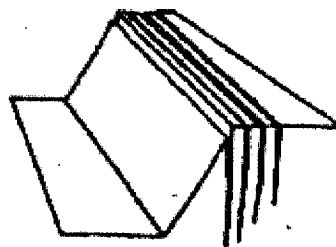

Figure 1: Vertically Jointed Rock slopes

Question Two

Large underground caverns mined in jointed rock face many structural problems. These carvens are however useful and find many uses especially as machine halls in hydropower generation statons and as storage chambers.

With reference to Figure 2, discuss the incidence of mining large underground caverns in jointed rock, under the following headings:

- (a) Typical Problems (5 marks)
- (b) Critical Parameters (5 marks)
- (c) Analysis Methods (5 marks)
- (d) Acceptability Criteria. (5 marks)

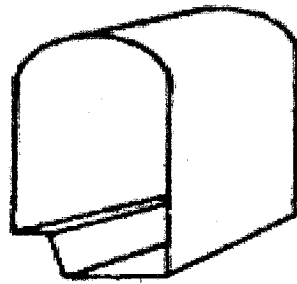

Figure 2: Large carvens in jointed rock

Question Three

A 50m high slope (Figure 3) with a face angle of 60° is found to have a bedding plane running through it at a dip of 30° . A tension crack occurs 15m behind the crest of the slope and from an accurately drawn cross section of the slope, the tension crack is found to have a depth of 25m. Refer to attached graphs and equations at the end of the paper.

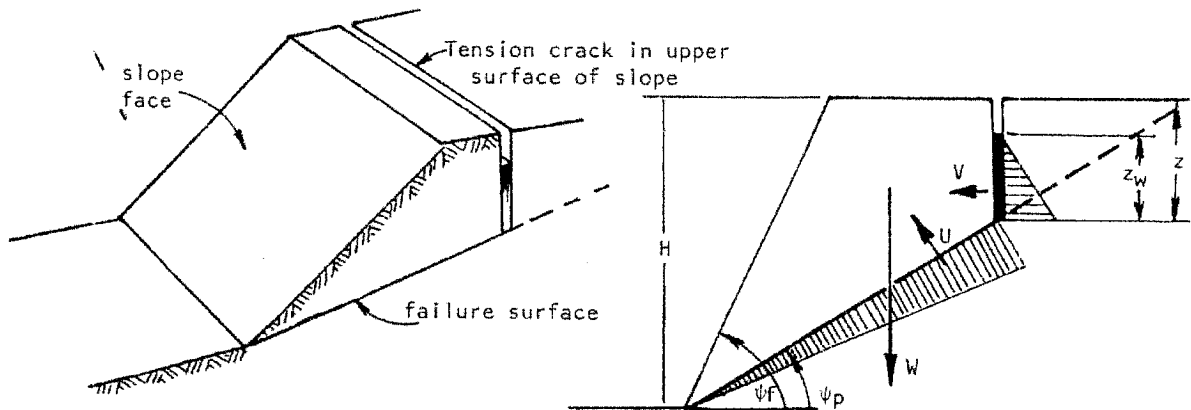

Figure 3: 50m high slope with force diagram

The unit weight of the rock is $\gamma = 30\text{kN/m}^3$ and that of the water $\gamma_w = 9.81\text{kN/m}^3$. Assuming that the cohesive strength of the bedding plane $c = 50.50\text{kN/m}^2$ and the friction angle ϕ is 30° .

- Find the influence of the water level Z_w upon the Factor of Safety of the slope. **(10 Marks)**
- Find the Factor of Safety of the slope graphically if the tension crack is only half full of water. **(5 Marks)**
- Make general comments/observations on your findings. **(5 Marks)**

Question Four

Water has potentially disastrous effects when present in rock slopes and many other earth works including other natural earth structures. Write short notes on the following in as far as the influence of rain and ground water on stability of earth works is concerned:

- (a) Dry Slopes (4 marks)
- (b) Water in slope tension crack (4 marks)
- (c) Water in tension crack only (4 marks)
- (d) Water in tension crack and on sliding surface (4 marks)
- (e) Saturated slope with heavy re-charge. (4 marks)

Question Five

Mining operations produce a lot of waste rock material which of necessity must be stored or dumped somewhere to make mining operations accessible and sustainable. The construction of these dumps or embankments is important as more often than not, they can fail with disastrous effects especially when dumping is near populated areas or on ground higher than the surrounding areas.

- (a) What does the term "Waste Embankment" mean and include? (5 marks)
- (b) Given a two-berm dump with the material specifications as listed, find the length L at which the condition of limiting equilibrium in the embankment will be established. (15 marks)

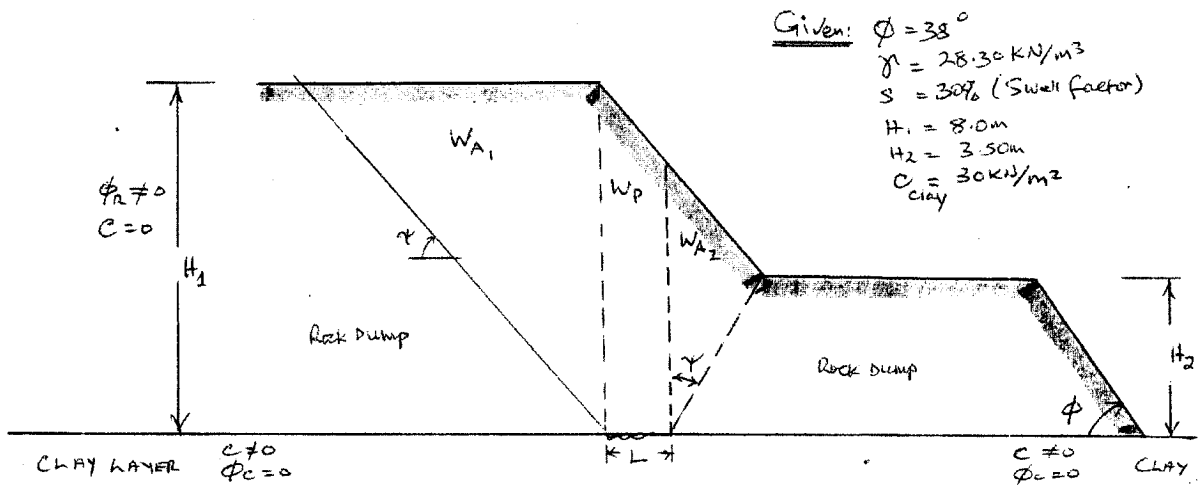
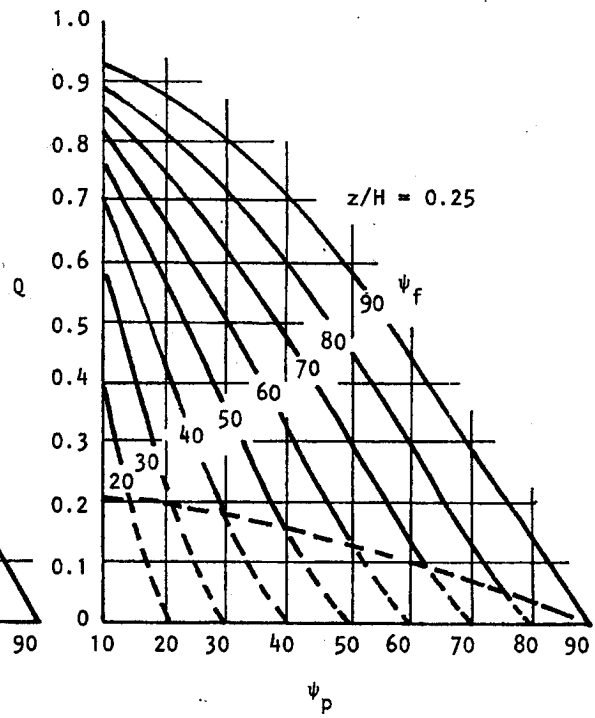
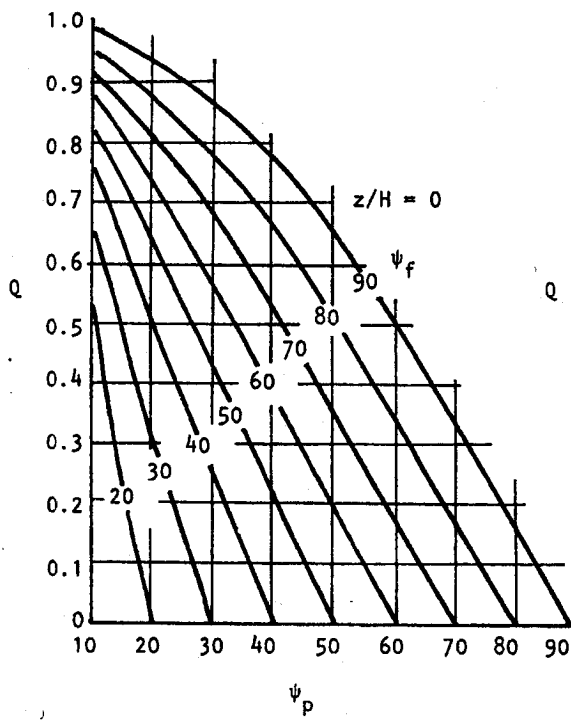
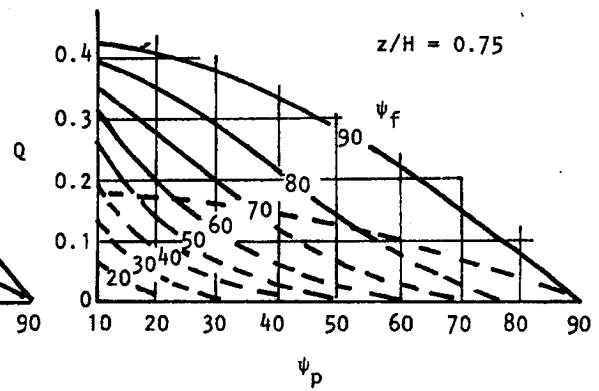
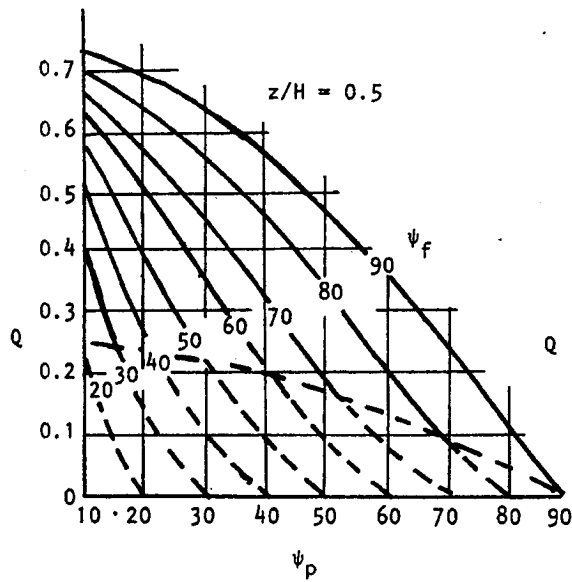

Figure 4: Two-berm waste dump

END OF EXAMINATION



Note:
Dashed lines refer to tension crack
in slope face.



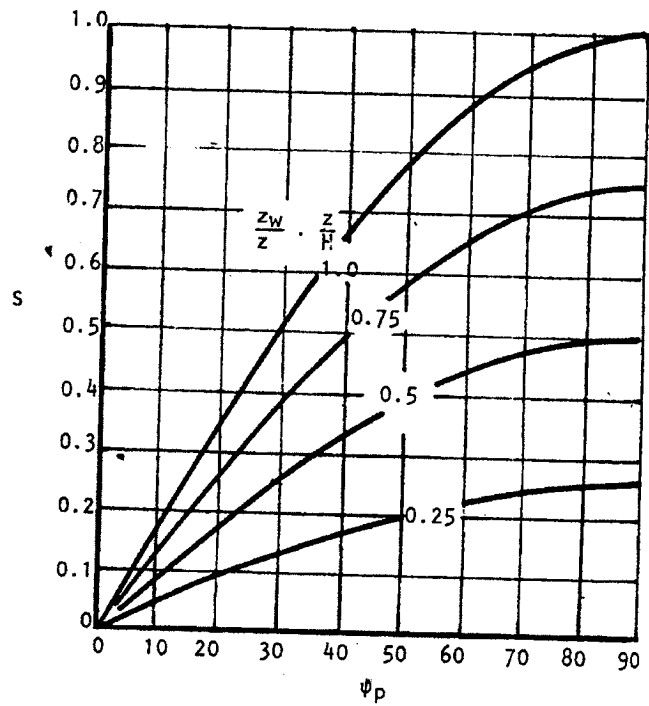
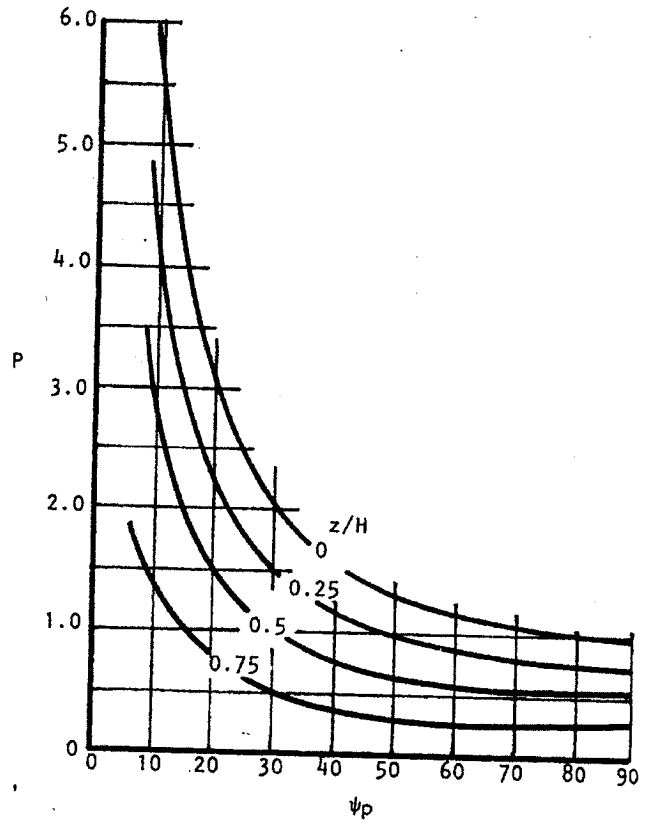
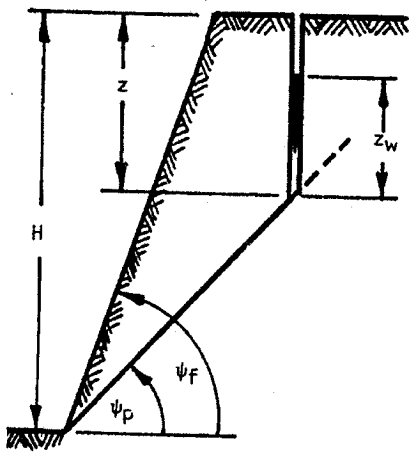

Equations

$$F.S = \frac{C.A + (W * \cos \psi \rho - U - V * \sin \psi \rho) \tan \theta}{W * \sin \psi \rho + V * \cos \psi \rho}$$

$$W * \sin \psi \rho + V * \cos \psi \rho$$

$$P = (1 - z/H) * \operatorname{Cosec} \psi \rho$$

$$Q = [(1 - (z/H)^2) \cot \psi \rho - \cot \psi_f] \sin \psi \rho$$

$$Q = [(1 - z/H)^2 \cos \psi \rho (\cot \psi \rho * \tan \psi_f - 1)]$$

$$R = \gamma_w / \gamma * Z_w / Z * Z / H$$

$$S = Z_w / Z * Z / H \sin \psi \rho$$

$$A = (H - Z) * \operatorname{Cosec} \psi \rho$$

$$U = 1/2 \gamma_w * Z_w * (H - Z) * \operatorname{Cosec} \psi \rho$$

$$V = 1/2 \gamma_w * Z_w^2$$

$$F = \frac{(2C / \gamma H * \rho + (Q * \cot \psi \rho - R(P + S))) \tan \Phi}{Q + R * S \cot \psi \rho}$$

$$Q + R * S \cot \psi \rho$$

UNIVERSITY OF ZAMBIA
UNIVERSITY EXAMINATION – SEPTEMBER 2016

MIN 5029 – COAL MINING

INSTRUCTIONS: **ANSWER QUESTION 1 AND ANY OTHER FIVE (5)**

TOTAL MARKS: **100**

TIME: **3 HOURS**

CLOSED BOOK

- Q1. (a) What is the purpose of analysis of coal? Name the methods which are used for this purpose and name the elements which are obtained by these analysis. **[10 marks]**
- (b) What is meant by a lower rank and higher rank of coal? Write the basis of their classification. **[5 marks]**
- (c) Why should coal be washed before it is used for any purpose? Name a method and describe its principle of washing coal **[5 marks]**
- Q2. (a) In coal mines geological intrusions such as (i) faults (ii) folds and (iii) washouts are very often encountered. Write their cause of origin and effects over the coal mining extraction. **[8 marks]**
- (b) What is meant by “cyclothem” in context of coalbeds? **[2 marks]**
- (c) In case of a normal fault a seam was displaced by 20m. If throw of the fault was 10m, find the angle of “hade”. **[6 marks]**
- Q3 (a) Design a longwall face to give an output of one million tonne per year (assuming 250 working days available in a year) the equipment available is a double –ended ranging drum(DERD), having average cutting speed of 4m/minute, web of DERD equal to 2.5m, thickness of coal extracted per bite is 3.0m. Take specific gravity of coal equal to 1.7. Write all the dimensions of the face including name of equipment and their location on the face. **[10 marks]**
- (b) In a room and pillar coal mining, (Figure given below) all openings are 6.0m in width, driven on 18m centres and cross cuts on 24m centres. Calculate the percentage recovery (i) without pillar recovery and (ii) with recovery. **[6 marks]**

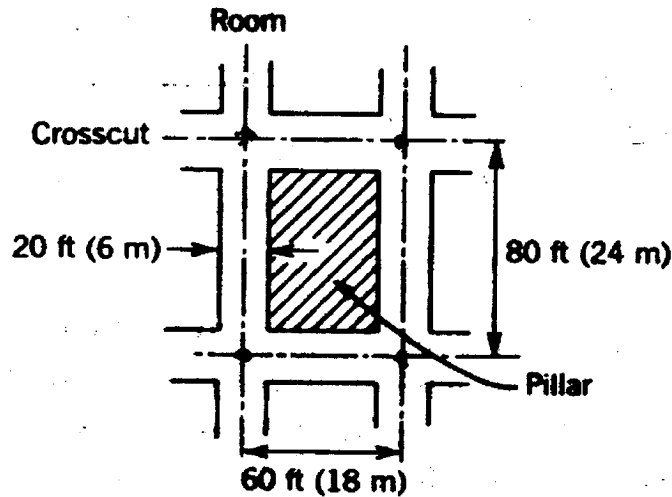

Note: Use SI units only in the above figure

Q4. (a) A coal deposit prone to spontaneous heating, at a depth of 250m is planned to be extracted. The management intends to avoid use of high voltage electricity for this extraction and transportation. Suggest a possible method of mining describing its principle of working. Write the advantages of the method you suggest. **[10 marks]**

(b) What is the purpose of protodyaknov apparatus? Has it got any application in mining? **[6 marks]**

Q5 (a) What is the difference between a longwall, shortwall and room and pillar mining? Write the situation in which these are recommended. **[10 marks]**

(b) Write the factors, taking into consideration of Coal Mining Regulations where ever applies, for fixing the size of the room and pillar, longwall and shortwall face. **[2x3 = 6 marks]**

Q6 (a) Write the provision of Coal Mine Regulation in case approaching (i) a suspected huge water deposit (ii) prevention of coal and silica dust and (iii) adequate ventilation. **[3x4 = 12 marks]**

(b) Name the diseases which may affect miners in coal mines. What precaution should be taken to avoid exposure to these diseases? **[4 marks]**

Q7 (a) A steeply inclined coal seam having dip of 20° planned to be mined. Suggest a suitable method for mining such a coal with the help of simple diagrams. **[8 marks]**

(b) What is a coking coal and how it is made? Write its uses **[8 marks]**

END OF EXAMINATION

Question 3

- (a) Discuss the situation in which a false roof mining method is used. Explain the working principle of this method, and hazards associated with it? [8 marks]
- (b) Where is horizon mining technique used and what is its working principle. Write the conditions in which this method is recommended. [8 marks]

Question 4

- (a) Explain the four situations in which (i) room and pillar mining and (ii) longwall of mining are most suited. [8 marks]
- (b) In a room and pillar mining, write the factors for which the number of pillars are fixed in a panel. [8 marks]

Question 5

- (a) Write the provisions of the Coal Mine Regulations if you are expecting a large pocket of water in the underground coal mine. [8 marks]
- (b) Referring to Figure 1, calculate the percentage in the panel
- (i) without pillar recovery [4 marks]
- (ii) with pillar recovery [4 marks]

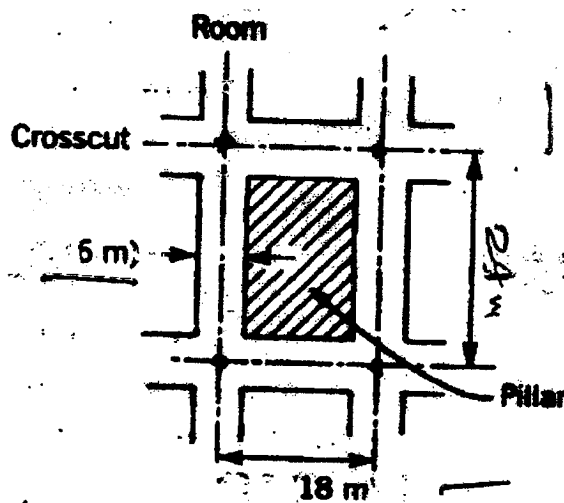

Figure 1: Coal Panel

Question 6

- (a) Where would you recommend use of longwall retreat mining? Give reasons. **[8 marks]**
- (b) The production capacity of a mine depends on how mine cars (or tubs) are handled at the surface and underground. Discuss factors that you consider when designing an ideal surface layout. **[8 marks]**

Question 7

- (a) (i) What is the difference between (i) normal fault and (ii) reverse fault? **[3 marks]**
- (ii) Explain using diagrams how these are caused. **[3 marks]**
- (iii) Write the problems due to their presence. **[2 marks]**
- (b) (i) What is a washout in coal mining? **[2 marks]**
- (ii) Explain how it is caused. **[3 marks]**
- (iii) What problems can it cause in the extraction of coal? **[3 marks]**

END OF EXAMINATION

UNIVERSITY OF ZAMBIA

UNIVERSITY EXAMINATIONS – SEPTEMBER 2016

MIN 5045 – MINE MANAGEMENT

INSTRUCTION: ANSWER ALL QUESTIONS

TOTAL MARKS: 100

TIME: 3 HOURS

CLOSED BOOK

QUESTION 1

- a) Use the thinking of the following on management to define and trace principles of management (The Italians, Latin, French Drucker, Fayol, Follet, General Sun Tsu, Niccolo Machiavelli) [10 marks]
- b) List briefly and discuss the eleven approaches to the study of management [10 marks]

QUESTION 2

Highlight the theories and the practical application of the following

- | | |
|--------------------------------------------------------|------------|
| (i) Taylor and scientific management | [2½ marks] |
| (ii) Fayol and 14 principles of management | [2½ marks] |
| (iii) Weber on power and bureaucracy | [2½ marks] |
| (iv) Maslow | [2½ marks] |
| (v) Herzberg | [2½ marks] |
| (vi) Mayo and the western electric company experiments | [2½ marks] |
| (vii) McGregor's theory X and Y | [2½ marks] |
| (viii) Ounuchi theory Z | [2½ marks] |

QUESTION 3

- (a) Discuss why organisations are typified on how they react to change [5 marks]
- (b) Write the consequences of structuring organisations of management [2 marks]
- (c) Comment on what is so common in all organisations [2 marks]
- (d) Comment on the differences managers and leaders [3 marks]
- (e) Write short notes on
- | | |
|---------------------------------------|-----------|
| (i) Trait theories of management | [4 marks] |
| (ii) Situation approach to management | [4 marks] |

QUESTION 4

- (a) Write short notes on vision, goals and objectives of organisations [6 marks]
- (b) Discuss how stakeholders can help or hinder the progress of organisation [6 marks]
- (c) List and discuss the ten (10) desired qualities of leaders of organisations [8 marks]

QUESTION 5

- (a) Write why cultural values are so critical to successful work in modern organisation
[6 marks]
- (b) Comment on the GOLDEN CARE principles of managing customers [8 marks]
- (c) In contemporary thinking ethics and codes of practice are important to uphold in professional practices why?
[6 marks]

END OF EXAMINATION

UNIVERSITY OF ZAMBIA
UNIVERSITY EXAMINATION – SEPTEMBER 2016

MIN 5049 – APPLICATION OF COMPUTERS IN MINING

INSTRUCTIONS:	ANSWER <u>ALL</u> QUESTIONS	TOTAL MARK:	100
TIME:	3 HOURS	CLOSED BOOK	

Question 1

The orebody model given in the folder (Exam1) is feasible to be extracted by surface mining method up to 46.418m level, and the rest of the deposit must be extracted using underground mining method with the mode of transportation for ore and waste to be done through a ramp from 40metre level to -419.779m level.

Note: the parameters of the pit are 10m bench height, berm width of 5m, batter angle 50° and at least with 3 switch backs.

Note: the parameters of the underground mine openings are to be: width of the cross section 2 metre and 1.5m height with a dome shaped roof of all horizontal openings including the decline and ventilation raise of 2m diameter.

The parameters of the underground mine are as follows: Between levels 100m, between stopes 20m, between crosscuts 30m and find the optimal way of connecting them to the draw cones.

Note: For the underground part please develop all the necessary underground opening such as the haulages, cone drives, crosscuts, drifts and ventilation raise to gain more marks.

[50 marks]

Question 2

As a Mine Planning Engineer working at the mine and using Surpac mining software you have been asked to:

- (a) Clip the pit you have designed in **Question 1**, the topography of the area and combine the two on the same layer to form the final pit; **[10 marks]**
- (b) Determine the total volume of (waste plus ore) to be extracted from the open pit taking into account the pit limits and the topography of the area; **[10 marks]**
- (c) Determine the total volume of ore inside the pit; **[10 marks]**
- (d) Given that the density of the copper ore is 2.6t/m^3 and the average copper grade is 1.5%.
 - (i) Calculate the total tonnage of the ore inside the pit; **[10 marks]**
 - (ii) Determine the available ore reserve in tonnes of the ore inside the pit in terms of metal content. **[10 marks]**

END OF EXAMINATION

Question 2 (60 marks)

The following are the string files of the Millennium copper deposit located in the North Western region of Zambia (see Figure 2).

- Large10.dtm, and
- topol.dtm.

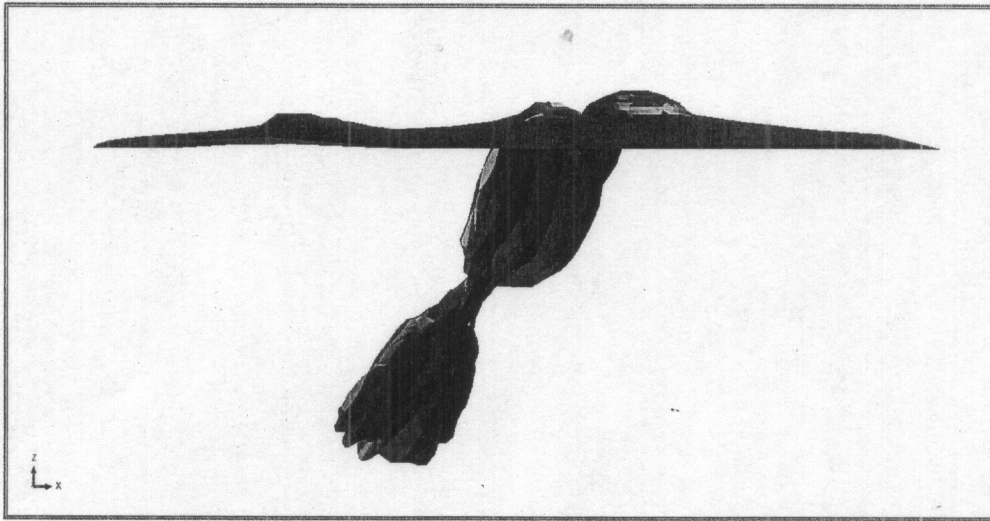

Figure 2: String files of Millennium copper deposit

A mining corporation wants to exploit the above orebody using longitudinal sublevel caving. The footwall and hanging wall of the orebody constitutes of granite (25 metres) and banded sandstone (15 metres), respectively. Hired as a mine planning engineer, employ Gemcom Surpac software to:

(a) Design a 5.5 m x 5.5 m decline having the following attributes:

- Starting point on surface – (5763.705, 4340.028, 450)
- Length of curvature – 188.5 metres
- Gradient – 1 in 8
- Ending point – -21 metre elevation

[15 marks]

(b) Design a sublevel longitudinal mining layout from the surface ending at -21 metre elevation. The longitudinal mining layout should have the following attributes:

- (i) Four 5 m x 5 m evenly spaced haulages **[5 marks]**
- (ii) Four 4.5 m x 4.5 m evenly spaced footwall drives **[5 marks]**
- (iii) Four 4.5 m x 4.5 m evenly spaced cross cuts on each level **[5 marks]**
- (iv) Four 4.5 m x 4.5 m extraction drives **[5 marks]**

- (c) Design the following
- (i) 2 ore passes (3 metres in diameter connecting all six levels) [4 marks]
 - (ii) Hoisting shaft (6 metres in diameter) [4 marks]
 - (iii) Haulage level (5.5 m x 5.5 m) [2 marks]
- (d) Determine the volume of material to be removed from
- (i) Decline [1 marks]
 - (ii) Longitudinal mining layout [3 marks]
 - (iii) Ore passes [1 mark]
 - (iv) Hoisting shaft [1 mark]
 - (v) Haulage level [1 mark]
- (e) If the total cost of development is \$1500/m³ (for all primary developments) and \$1200/m³ (for all secondary developments), What is the total cost of developing;
- (i) All primary developments [4 marks]
 - (ii) All secondary developments [4 marks]

END OF EXAMINATION

UNIVERSITY OF ZAMBIA
UNIVERSITY EXAMINATION – SEPTEMBER 2016

MIN 5065 – SAFETY HEALTH AND ENVIRONMENT

INSTRUCTIONS: ANSWER ALL QUESTIONS
TIME: 3 HOURS

CLOSED BOOK
TOTAL MARKS: 100

Question 1

Job Hazard Analysis can be a valuable planning, production, profit and safety tool at a given mining firm. Briefly describe steps applied when conducting Job hazard analysis (JHA).

[20 marks]

Question 2

Outline critical steps and processes that are key in successful implementation of behavior based safety (BBS) in a given organisation. How does the “effect of punishment” and “effect of extinction” affect behavior?

[20 marks]

Question 3

An accident resulting from collision of two dump trucks has just happened at Mine Y in the main extraction level located at 900 m below surface. There is great panic in that apart from loss of three miners, there is a possibility of further accident happening (fire) due to spillage of previously an unidentified hazardous substance in the level. As an expert you have been tasked to investigate the accident and submit a report to management. Explain in logical sequence how you would investigate the accident scene.

[20 marks]

Question 4

A dish containing 12.7 g of carbon tetrachloride is placed in a sealed cubical chamber with inside dimensions of 2.1 m for each edge. The final temperature is 22.5 °C and the barometer reading is 765 mm Hg.

- (a) What concentration (ppm) is achieved? **[5 marks]**
- (b) What is the concentration in mg/m³ under ambient conditions? **[10 marks]**
- (c) What is the concentration in mg/m³ standard conditions? **[5 marks]**

Question 5

A review of major accidents and fatalities in mining indicate that most of these arise from industrial sub systems which are strongly coupled with significant interactions. Using logic modeling, briefly explain how “*unsafe mine environment*” contribute to mine accidents:

[20 marks]

END OF EXAMINATION

UNIVERSITY OF ZAMBIA

UNIVERSITY EXAMINATIONS – AUG / SEPT 2017

MIN 5069 - SAFETY HEALTH AND ENVIRONMENT

INSTRUCTIONS: ANSWER ALL QUESTIONS

TIME: 3 HOURS

TOTAL MARKS: 100

Question 1

Job hazard analysis can be a valuable planning, production, profit and safety tool at a given mining firm. Briefly describe steps applied when conducting job hazard analysis. [20 marks]

Question 2

Outline critical steps and processes that are key in successful implementation of behavior based safety in a given organisation. How does the “effect of punishment” and “effect of extinction” affect behavior? [20 marks]

Question 3

- a) Why is it important to review and evaluate a mining occupational safety management system? [5 marks]
- b) You have been appointed as Mine Manager for ABX Company. Unfortunately, you have discovered that the company has no occupational Health and Safety Policy (OHS). Draft a policy and comment on the salient features. [15 marks]

Question 4

- a) Calculate the sound pressure level of a typical gasoline-powered lawn mower, which has a sound pressure of 1 Pa. The reference sound pressure is 0.00002 Pa. [2 marks]
- b) Briefly describe the effect of excessive noise exposure on the ear under the following sub headings:
 - i. Noise – induced Temporary Threshold shift [6 marks]
 - ii. Noise – induced Permanent Threshold Shift [6 marks]
 - iii. Tinnitus [3 marks]
 - iv. Acoustic Trauma [3 marks]

Question 3

- a) Describe physical and mechanical properties which affect drilling performance. [6marks]
- b) With reference to copper ore deposit, explain three (3) factors that determine a cutoff grade. [5marks]
- c) Calculate the required:
- i. Bits, [2marks]
 - ii. Shank adapters, [2marks]
 - iii. Sleeves, and [2marks]
 - iv. Rods. [3marks]

Given:

Production	=	1,000,000 tonnes
Density	=	4 tonnes/m ³
Specific drilling	=	0.5
Average service life (life span) of:		
51mm button bit	=	450m
Shank adapters	=	3,500m
Sleeves	=	250m
R32 rods	=	150 holes
R32 rod length	=	1.8m.

Question 4

- a) Explain why different underground mining methods are used for different ore bodies. [7marks]
- b) Describe three major variants under geo-mechanical classification of underground mining methods and give three examples under each class. [7marks]
- c) Apart from rock mechanics classification of mining methods based on support offered to generated mine structure and type of magnitude of rock displacement, describe any other type of classifying mining methods. [6marks]

Question 5

- a) With help of diagrams, explain how lithostatic and deviatoric stresses affect mine excavation stability. **[6marks]**
- b) Block size is estimated as one of three indices of rock quality designation, volumetric joint count, and block size index. Explain how block size influence the stability and strength of underground mine excavations. **[6marks]**
- c) An open pit project has a cylindrical ore body with 110m height and 20m diameter:
- Calculate the stripping ratio if the overburden is cone shaped with 29m diameter and 160m height. **[3marks]**
 - If the cost of removing waste is as same as the cost of extracting ore, comment on viability of the project. **[2marks]**
 - With help of diagrams, explain how the profitability of the project can be improved. **[3marks]**

Question 6

- a) If the friction winder rope will slip at $T_1 / T_2 \leq 4.34$, calculate the angle of wrap in degrees, given the coefficient of friction of 0.44. **[4marks]**
- b) There are three principal types of hoists used in mining applications, describe the most commonly used winder in Zambia, giving reasons why it is common. **[6marks]**
- c) It is required to sink a shaft from surface to the ore body 640m deep, using a conventional method. The operations are being carried on a three-shift per day basis. The rock hardness is about 75MPa. If 39 blast holes are drilled and blasted per shift:
- Estimate the cross section area of the shaft. **[2marks]**
 - Estimate how long it will take to complete sinking the shaft **[3marks]**
 - Propose the support system suitable for this shaft. **[2marks]**
 - Describe advantages of conventional method of shaft sinking. **[3marks]**

END OF EXAMINATION

UNIVERSITY OF ZAMBIA
UNIVERSITY EXAMINATION – SEPTEMBER 2016

MIN 5079 – ROCK MECHANICS II

INSTRUCTIONS: **ANSWER QUESTION 1 AND ANY OTHER FIVE (5)**

TOTAL MARK: **100**

TIME: **3 HOURS**

CLOSED BOOK

- Q1. (a) Disposal of mill tailing and coal fines must be done with care to prevent their failures. Describe how the site is selected for this purpose. **[10 marks]**
- (b) What is meant by liquefaction failure? Write the factors which trigger the above failure. **[5 marks]**
- (c) A sample of saturated clay weighed 1526g in its natural state and 1053g after drying. If the unit weight of the soil is 2.70g/cm^3 , determine (i) the void ratio and (ii) the porosity. **[2½ x 2 = 5 marks]**
- Q2. (a) A number of rock mass classification schemes have been developed for a variety of purposes. Among them, the CSIR (RMR) and NGIQ. System are widely used in mining and civil engineering practices. List the parameters that are considered under these rock classification schemes and explain their relevance in characterizing rock. **[10 marks]**
- (b) Estimate the maximum possible unsupported span that will remain stable in case of a tunnel in the rock where,
- | | |
|-----------|-----------|
| RQD = 90 | SRF = 15 |
| $J_n = 4$ | $J_r = 3$ |
| $J_w = 1$ | $J_a = 1$ |
- [6 marks]**
- Q3. (a) For the stability of rock strata reinforcement of rock is most preferred since it has several advantages over the conventional type of support. Explain with the help of diagrams the supporting principle of the rock reinforcement. **[6 marks]**
- (b) It has been planned to use rock bolts to prevent a tetrahedral block suspected to be separated from its parent mass. The specification of the rock block are given below:
- Area of the block = 350m^2
 - Volume of the block = $7,000\text{m}^3$
 - Average density of rock block = 2.5kNm^{-3}
 - Cohesive strength (c) of sliding surface = 0.052MPa
 - Dip of sliding surface (Ψ) = 45°
 - Frictional angle of sliding surface (Φ) 23°
 - Angle of plunge of bolt (Θ) = 67°
 - Number of bolts to be used = 25
 - Factors of safety to be maintained = 1.6

From the above data find

- (a) tension of each bolt in tonnes
- (b) spacing between two bolts (in metres) and
- (c) length of the bolt (in metres)

[10 marks]

Q4 (a) Explain with the help of diagrams what causes discontinuous (erratic) and uniform (trough-type). Subsidence over the surface due to underground mining [8 marks]

(b) (i) List the factors which are normally responsible for surface subsidence and suggests some measures to minimize such subsidence. [4 marks]

(ii) If mining is taking place at 300m depth for extraction of and using a longwall method. If the width of longwall panel is 330m and angle of draw likely to be 27° , find the safe distance over the surface which will not be affected by such underground working? [4 marks]

Q5 (a) What are the main factors for the occurrence of rockbursts in underground mining and how this can be controlled? [8 marks]

(b) (i) Show the position of the equipment to be located in the mine for getting pre-alarm of this occurrence. [4 marks]

(ii) Calculate the seismic energy (in Jules) if the magnitude of the tremor in Richter's scale i.e. 4.5 [4 marks]

Q6 (a) What are the main objectives of underground instrumentation in geomechanic context?

(b) What is meant by (i) accuracy (ii) error and (iii) sensitivity of an instrumental [6 marks]

(c) A 10MPa pressure gauge having an accuracy of 1%. What would be accurate reading in 100 kPa gauge range? [4 marks]

Q7 (a) Discuss the tributary area method, using diagram, of estimating average state of axial stress used in the design of mine pillars. [5 marks]

(b) Estimate the size of pillars required for stability and then (ii) the extraction ratio (defined as the ratio of excavated mineral to total original in the rooms and pillars mining. Given:

- Depth of mine = 100m
- Density of overburden rock = 25kNm^{-3}
- Strength of Mineral (Coal) = 10 MPa
- Number of pillars in the parallel = 9 (nine)
- Factor of safety to be maintained = 1.2
- Panel size = 100 x 100m

[5x2=10 marks]

END OF EXAMINATION

UNIVERSITY OF ZAMBIA
UNIVERSITY EXAMINATIONS – AUG/SEP 2017

MIN 5079 – ROCK MECHANICS II

INSTRUCTIONS: ANSWER QUESTION 1 AND ANY FIVE (05)

TIME: 3 HOURS

TOTAL MARK: 100

Question 1

- (a) (i) Explain the difference between an active support and passive support giving examples. **[2½ marks]**
- (ii) Suggest five (5) major methods for improving rock properties in underground mine. **[2½ marks]**
- (b) Before rock reinforcement is carried out to stabilize a rock block certain parameters must be studied to make reinforcement effective. Name these parameters and briefly describe how these can be known. **[5 marks]**
- (c) A highway has to pass through a section of a hillock of which both sides walls must be stabilised, using rock bolt. The details of the site are A motorway has to be driven through the middle of a hillock of both sides needs to be stabilized using steel bolts. The details of the site to be bolted are given below:
- Volume of the rock to be bolted = $7,500\text{m}^3$
 - Average density of rock = 26kN/m^3
 - Cohesive strength of sliding surface $c = 0.52\text{Mpa}$
 - Dip of sliding surface (ψ) = 45 degrees
 - Frictional angle of sliding surface (ϕ) = 23 degrees
 - Angle between the plunge of the bolt and normal to strata (θ) = 90 degrees.
 - Recommended factor of safety = 1.6
 - If number of bolts to be used are 25, calculate the tension in each bolt (in tonnes). **[5 marks]**
- (d) How is the length and spacing between the two bolts (along and transverse direction) calculated. If the rock block is likely to spall what measure would you take to control it? **[5 marks]**

Question 2

- (a) Mining induced surface subsidence could be either uniform (trough type) or erratic (chimney type, cavity type etc). Explain with the help of diagrams the reasons for it. **[3 marks]**
- (b) A stratified mineral deposit of 3.0m thickness at a depth of 300m to be extracted using a longwall method. What should be the maximum width of the panel (in metres) so that the subsidence should not reach to the surface? **[3 marks]**

- (c) What measures are taken to control such subsidence? [3 marks]
- (d) What is meant by “angle of draw” in context of mining subsidence? How this can be estimated? Show by means of a simple diagram. [7 marks]

Question 3

- (a) In underground mining pillar design is based on three major factors. Write these factors and explain their relevance in the pillar design [8 marks]
- (b) Using tributary area method of mining calculate what cross – section area of a pillars’ will be needed so that it remains safe until it is extracted. Given the plan area of the panel = 10,000 (100m x 100m)m².
- Number of pillars should be = 9
 - Depth from the surface = 100m
 - Density of overlying rock = 25kN/m³
 - Factor of safety = 1.2
 - Strength of pillar = 10MPa

[8 marks]

Question 4

- (a) What are the purposes of rock mass classification? [5 marks]
- (b) What are the similarities and differences between the Rock Mass Rating (RMR) and Q. System of rockmass classification? Explain the situation in which these two systems are preferred? [6 marks]
- (c) If the value of RMR is 75, find the value of Q. Comment on the type of rock and give two examples in this category. [5 marks]

Question 5

- (a) What causes micro seismic activity which may result into an earthquake and rockbursts in an underground mine? [4 marks]
- (b) Write five principal measures to reduce rockbursts? [4 marks]
- (c) Describe briefly a seismic detection system that shows the sequence of events for this purpose [4 marks]
- (d) Calculate the seismic energy released from the rockbursts (in Joules) if the tremor magnitude (ML) was 7.5 on Richter scale. [4 marks]

Question 6

- (a) In an engineering design a risk assessment is of prime importance for safe design. Describe how this is done. **[8 marks]**
- (b) How is the bearing capacity of a floor rock /soil estimated? **[8 marks]**

Question 7

- (a) “The closure of a mine involves consideration of a range of environmental, social and economic factors” Discuss some salient features of the above statement. **[8 marks]**
- (b) Calculate the pore water pressure (P_w) which may cause fracture in a water reservoir made in sandstone if the values of σ_3 and σ_1 in triaxial test are equal to 10 MPa and 35 MPa respectively. The values of q_u is 1.2 MPa and angle of internal friction (ϕ) is 40° . **[8 marks]**

END OF EXAMINATION

UNIVERSITY OF ZAMBIA
UNIVERSITY EXAMINATION – SEPTEMBER 2016

MIN 5089 – MINE PLANNING AND DESIGN

INSTRUCTIONS:	ANSWER <u>ALL</u> QUESTIONS	TOTAL MARK:	100
TIME:	3 HOURS	CLOSED BOOK	

Question 1

Consider a case where a 20-tonne capacity, articulated dump truck hauls ore to the surface. Ore is loaded into the truck by a 6.1m³ capacity, remote bogger near the entrance to a CAF stope. The truck hauls the ore 550m along a nearly level drift, then 1450m up a 10% gradient to the surface. Once on the surface the truck travels another 200m to the mill, where the ore is dumped into the crusher feed bin. Assume the following speeds (from technical manuals supplied by manufacturers).

- Up a 10% gradient, loaded @ 6.4kmph;
- Over a level segment, loaded @ 16.1kmph;
- Over a level segment, empty @ 20.3kmph;
- Over a 10% gradient, empty @ 15.8kmph.

Answer the following questions;

- a) Estimate the travel time for the truck. **[5 marks]**
- b) If the following data applies: Bogger capacity = 5.44 tonnes; round trip from dump point to stope (bogger) = 2.5 minutes; dump time (bogger) = 0.4 minutes; truck dump time = 0.4 minutes; truck turning and manoeuvring = 2.25 minutes, calculate the total cycle time. **[5 marks]**
- c) If the mine operates two 10-hour shifts per day, how many tonnes can the truck haul per day? **[5 marks]**
- d) If the mine production rate = 4,000 tonnes per day, what is the required number of trucks? **[5 marks]**

Question 2

Consider the block model shown in Figure 1 in which 10 ore blocks are overlain by 12 waste blocks. As the mining engineer you have been asked to prepare a production schedule for this operation.

W	W	W	W	W	W	W	W	W	W	W	W
	O	O	O	O	O	O	O	O	O	O	

Legend: O = Ore, W = Waste;

Figure 1: Vertical section through a mineral deposit showing the final pit limit

You have been provided with the following planning data:

- Maximum production rate = 6 blocks per year (regardless of whether the blocks are ore or waste)
- Minimum production rate = 4 blocks per year (regardless of whether the blocks are ore or waste)
- The net value (profit) of an ore block = +\$200,000/block
- The cost of removing the waste = \$100,000/block
- The overall slope angle to be maintained at all times = 45 degrees (1H:1V)
- Assume an interest rate = 10%; cash flows occur at the end of the year for discounting purposes.

Calculate the Net Present Value (NPV) for the following production scheduling scenarios. Be sure to indicate for each scenario which blocks are removed in each year. For example, W_1 if a waste block is mined in year 1 and O_1 if an ore block is mined in year 1. *Hint: Start mining from one end of the pit and develop the block removal sequence as required and always seek to maximise your mining capacity (rate).*

- a) **Scenario 1:** Removal of waste followed by ore mining (for operational reasons it would be good if all the waste could be mined first followed later by ore mining). **[4 marks]**
- b) **Scenario 2:** One year of pre-stripping followed by both ore and waste. This alternative requires removal of 6 waste blocks in year 1; followed by 5 ore blocks and 1 waste block in year 2; then 3 waste blocks and 3 ore blocks in year 3; finally 2 waste blocks and 2 ore blocks in year 4. **[4 marks]**
- c) **Scenario 3:** Mining waste maintained one block ahead of ore. This alternative requires removal of 3 waste blocks and 2 ore blocks in the first year, etc. **[4 marks]**
- d) **Scenario 4:** Mining rate doubled (8-12 blocks per year). Assume stripping is kept ahead of mining as in Scenario 3, but now waste mining cost = \$110,000/block; ore net value = \$190,000/block. **[4 marks]**
- e) From your analysis complete the Table 1 below. Reproduce Table 1 in your answer booklet and fill in columns headed 'Mine Life' and 'NPV': **[2 marks]**

Table 1 – Mine Life vs NPV Scenarios

Scenario	Mine Life (years)	NPV (\$)
1		
2		
3		
4		

- f) State **TWO** factors which affect the NPV in this case. **[2 marks]**

Question 3

(a) A coal seam is 4m thick at a depth of the coal floor below surface of 100m.

Bord and pillar mining is to be done.

- (i) Will this pillar size be sufficient to ensure a safety factor of 1.6? [4 marks]
- (ii) What will the centre to centre distance be? [3 marks]
- (iii) What will be the percentage extraction? [3 marks]

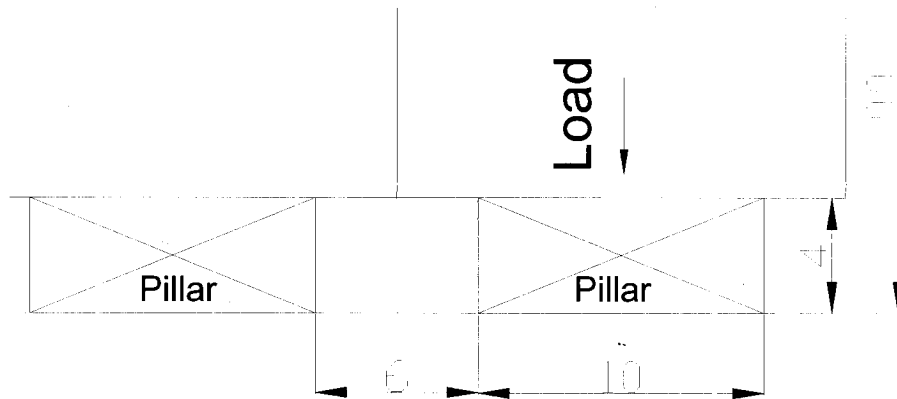

(b) Choose ONE mining method below;

- (i) Vertical Crater Retreat (VCR)
- (ii) Block caving
- (iii) Cut and Fill

For the mining method chosen and using a clear and well labelled diagram to illustrate your answer where possible, discuss the mining method in detail under the following headings;

- Development [4 marks]
- Operations [3 marks]
- Production [3 marks]

Question 4

At an Open Stopping operation, the vein dips from 65° to vertical to the southeast and strikes N $40-70^{\circ}$ E. Average width of the vein is 6.7m. The dimensions of the ore chute being mined are roughly 305m along strike by 160m vertically, although the lower limit of the chute is defined by the limitations of the mining method employed rather than ore tenor or mineralogical change. Draw points located at the bottom of the mine would be driven on 15.2-m centres from a lateral drift parallelling the vein in the footwall. This drift is located a minimum 15.2 m from the footwall of the vein in order to provide maximum ground stability and ensure that Bogger units would have a straight shot at the muck pile when bogging out of the draw points. Each

draw point would be coned up to an undercut level, driven in ore approximately 10.7m above the draw point brows, with the formation of pillar apexes at the undercut sill elevation.

The mine is laid out with a centrally located ramp system (10% grade) serving each of the five sub levels 35m apart. This ramp system consists of extremely elongated spirals located in the footwall of the vein with their long axis' positioned perpendicular to the strike of the vein. All openings are 3.6m high by 4.3m wide.

- a) Draw a vertical section (transverse), normal to the strike of the ore body. Show the vein and the ramp system and the location of the sub levels. [5 marks]
- b) Draw a vertical longitudinal section showing the draw points, the cones, the undercut, and the ore up to the first sub level. [5 marks]
- c) Draw a horizontal section (plan) at the draw point level. [5 marks]
- d) Draw the 3-dimensional perspective of this mining system. [5 marks]

Question 5

- (a) Explain the following terms as they relate to Whittle Optimization;
 - (i) Pit Shell; [2 marks]
 - (ii) Revenue Factor; [2 marks]
 - (iii) Pushback; [2 marks]
 - (iv) Mining CAF; [2 marks]
 - (v) Worst Case Scenario; [2 marks]

(b) The figures below show the Pit-by-Pit graph from Whittle optimization software;

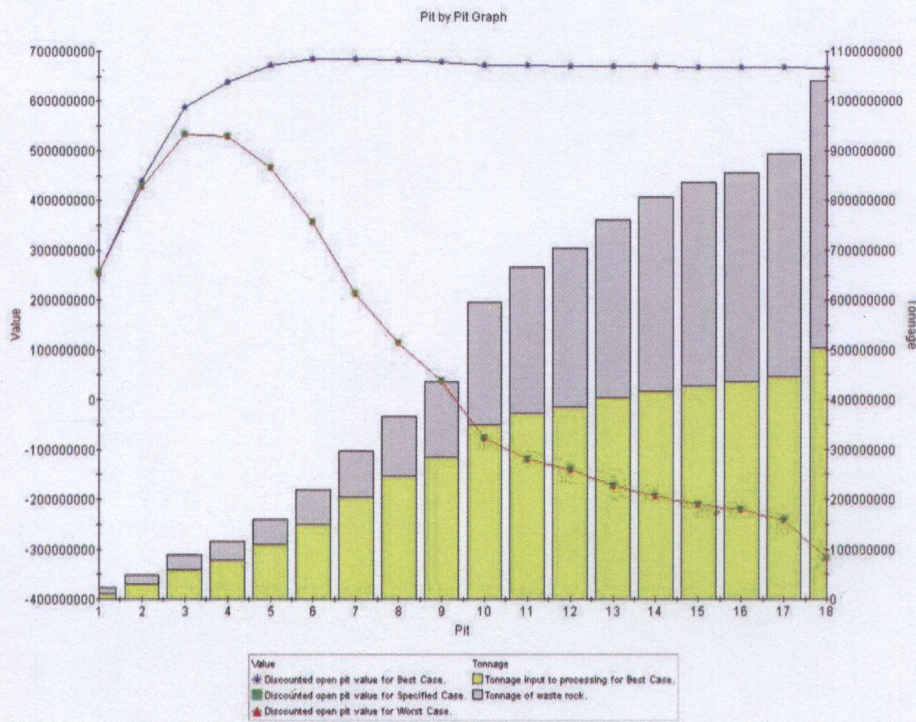

(a)

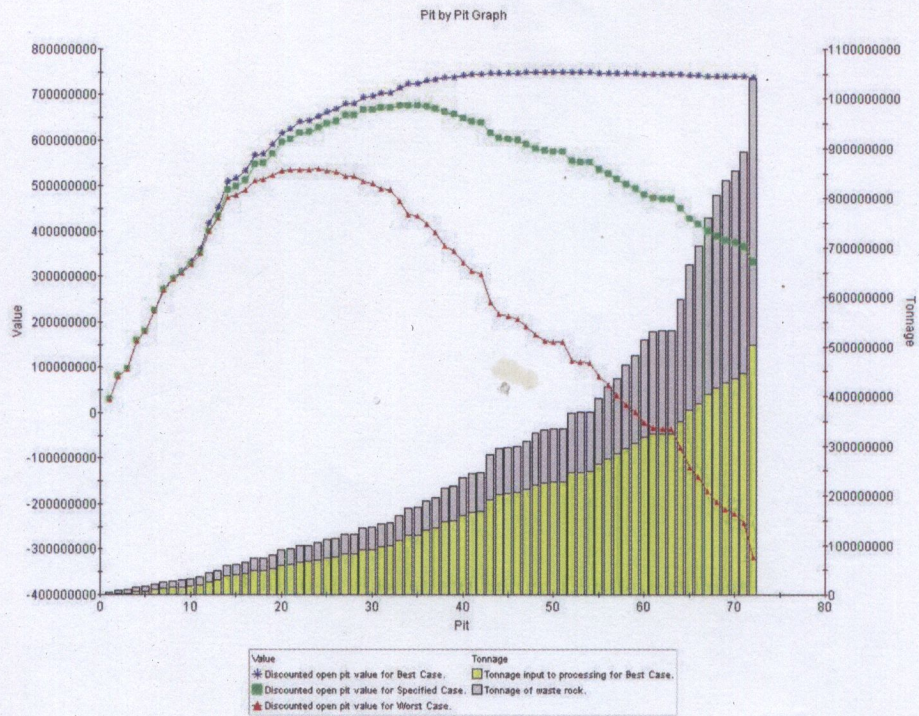

(b)

Figure 1: Pit-by-Pit graph from Whittle optimization software

- (i) Discuss the difference between Graph (a) and Graph (b) [3 marks]
- (ii) Explain briefly the meaning of "Specified Case" in Whittle; [2 marks]
- (iii) Discuss the process of selecting pushbacks from pit shells using Whittle; [5 marks]

END OF EXAMINATION

UNIVERSITY OF ZAMBIA
UNIVERSITY EXAMINATION – AUG/SEPT 2017

MIN 5089 – MINE PLANNING AND DESIGN

INSTRUCTIONS: ANSWER ANY FIVE (5) QUESTIONS TOTAL MARK: 100
TIME: 3 HOURS

Question 1

- (a) A coal seam is 4m thick at a depth of the coal floor below surface of 100m.
Bord and pillar mining is to be done (Figure 1).

- (i) Will this pillar size be sufficient to ensure a safety factor of 1.6? [4 marks]
(ii) What will the centre to centre distance be? [3 marks]
(iii) What will be the percentage extraction? [3 marks]

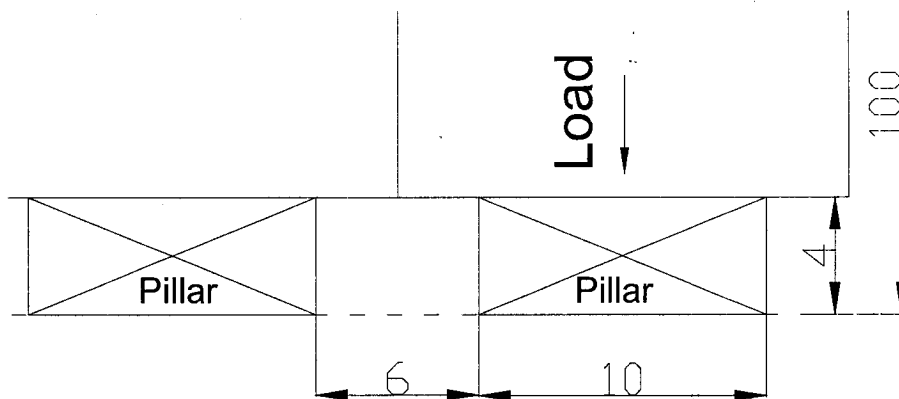

Figure 1: Bord and pillar mining (All dimensions in metres, not to scale)

- (b) Choosing either **Block caving** or **Sublevel caving**, and using a clear and well labelled diagram to illustrate your answer where possible, discuss the mining method in detail under the following headings;
- (i) Development [4 marks]
(ii) Operations [3 marks]
(iii) Production [3 marks]

Question 2

John Musenge, a Mine Planning Engineer with The-Way-to-Go Mining Company is developing a mine plan to expand the current pit production during the next period. The pit has six areas available for mining with the technical data shown in Table 1. During the planning meeting, the requirements for the schedule were specified as follows:

- Desired production: at least 2,500,000 tonnes
- Available truck hours = 5,000 hours
- Minimum average nickel grade: at least 0.5% Nickel
- Stripping capacity = 3,500,000 m³

Table 1: Mine planning data

Area	Ore Reserves (tonnes)	Av. grade (% Nickel)	Strip Ratio (m ³ /tonne)	Truck hours/tonne	Mining cost (\$/tonne)
1	750,000	1.0	3:1	0.002	10.0
2	750,000	1.5	2:1	0.001	15.0
3	250,000	0.35	1.5:1	0.0025	13.0
4	400,000	0.40	1:1	0.001	12.0
5	300,000	0.80	0.7:1	0.0027	20.0
6	700,000	0.60	1:1	0.003	17.5

Formulate a linear programming model to determine the mining plan that will minimise the total cost. **[20 marks]**

Question 3

- (a) Explain briefly the factors that influence the choice of a mining method; **[5 marks]**
- (b) A shallow dipping narrow vein ore body has been found on an unconformity at a depth of 500m, and extends to a depth of 3000m. The ore is being mined via a 1000m deep conventional shaft in the footwall and plans have to be made to extend mining to depths of 2000m and 3000m. It's envisioned that the present shaft will continue to operate at full capacity.

Discuss alternatives for the layout of shaft accesses to the deeper material which would have minimal effect on the rate of production from the present shaft. A neat sketch is expected and underground ramp haulage has been eliminated as an alternative because it is deemed to be less productive and more costly. **[15 marks]**

Question 4

- (a) What is the role of mining planning in mining ventures? **[5 marks]**
- (b) Discuss the main process / procedure involved in mine planning and design **[5 marks]**

- (c) At an Open Stopping operation, the vein dips from 65° to vertical to the southeast and strikes N $40-70^{\circ}$ E. Average width of the vein is 6.7m. The dimensions of the ore chute being mined are roughly 305m along strike by 160m vertically, although the lower limit of the chute is defined by the limitations of the mining method employed rather than ore tenor or mineralogical change. Draw points located at the bottom of the mine would be driven on 15.2-m centres from a lateral drift paralleling the vein in the footwall. This drift is located a minimum 15.2 m from the footwall of the vein in order to provide maximum ground stability and ensure that Bogger units would have a straight shot at the muck pile when bogging out of the draw points. Each draw point would be coned up to an undercut level, driven in ore approximately 10.7m above the draw point brows, with the formation of pillar apexes at the undercut sill elevation.

The mine is laid out with a centrally located ramp system (10% grade) serving each of the five sub levels 35m apart. This ramp system consists of extremely elongated spirals located in the footwall of the vein with their long axis' positioned perpendicular to the strike of the vein. All openings are 3.6m high by 4.3m wide.

- (i) Draw a vertical section (transverse) normal to the strike of the ore body. Show the vein and the ramp system and the location of the sub levels. [3 marks]
- (ii) Draw a vertical longitudinal section showing the draw points, the cones, the undercut, and the ore up to the first sub level. [2 marks]
- (iii) Draw a horizontal section (plan) at the draw point level. [2 marks]
- (iv) Draw the 3-dimensional perspective of this mining system. [3 marks]

Question 5

- (a) Explain the following terms as they relate to Whittle Optimization. Wherever possible, illustrate your answer.
- (i) Best Case; [2 marks]
 - (ii) Revenue Factor; [2 marks]
 - (iii) Pushback (cutback) in open pit mining; [2 marks]
 - (iv) Mining CAF; [2 marks]
 - (v) Worst Case Scenario; [2 marks]
- (b) Figures 2 and 3, show the Pit-by-Pit graph from Whittle optimization software;

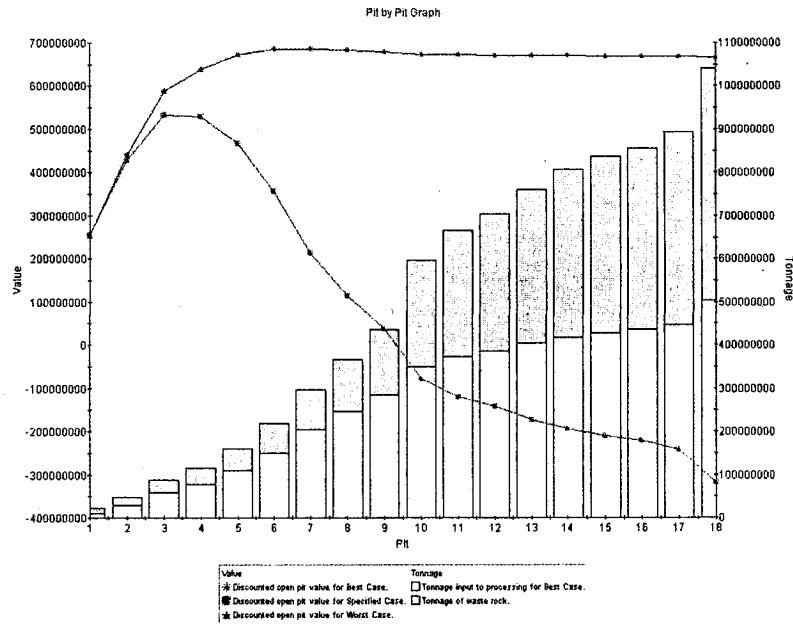

Figure 2: Pit-by-Pit graph

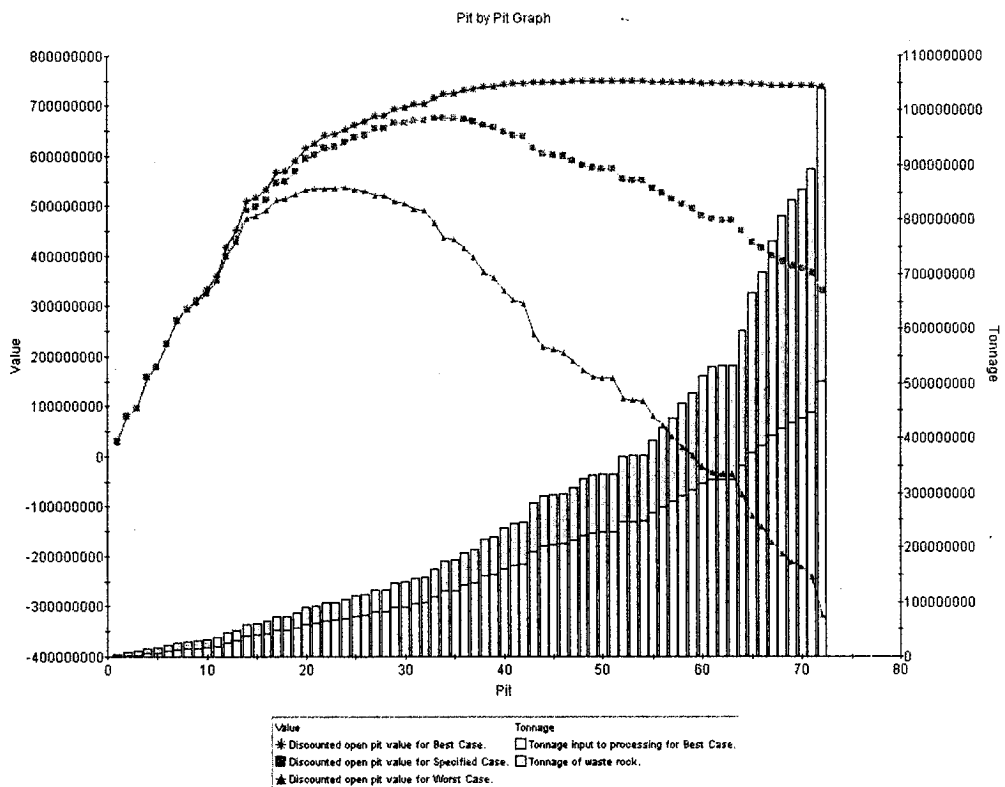

Figure 3: Pit-by-Pit graph

- (i) Discuss the difference between Figures 2 and 3 [3 marks]
- (ii) Explain briefly the meaning of "Specified Case" in Whittle; [3 marks]
- (iii) Discuss the process of selecting pushbacks from pit shells using Whittle; [4 marks]

Question 6

- (a) What are the main objectives of production scheduling? **[5 marks]**
- (b) Discuss the main inputs for a mine schedule. **[5 marks]**
- (c) Fort Jameson is a small shallow open pit mine with a mine life of 15 months. The mine engineer has developed the production schedule as shown in Table 2. Complete the missing details in Table 2. The stripping ratio is expressed in BCM waste per BCM ore. Round all values to one decimal place. Plot graphs to show the waste and ore movement over the life of the mine. **[10 marks]**

Table 2: Production Schedule for a gold mine

Parameter	May 02	June 02	July 02	Aug 02	Sept 02	Oct 02	Nov 02	Dec 02	Jan 03	Feb 03	Mar 03	Apr 03	May 03	Jun 03	Jul 03
Excavator total BCM/hr	480	470	460	450	450	450	450	430	430	430	420	420	420	450	450
Hours/shift	10	10	10	10	10	10	10	10	10	10	10	10	10	10	10
Shifts/day	2.25	3	3	4	4	2	2	2	2	2	2	1	1	1	1
Days/month	24	24	24	24	24	24	24	24	24	24	24	24	24	24	6
BCM/shift															
BCM/day															
Total (BCM x '000)															
Waste (BCM x '000)	259.0	337.6	329.6	428.4	426.9	213.4	213.6	204.4	204.3	202.6	196.1	97.2	96.0	100.6	23.5
Ore (BCM x '000)															
Ore (tonnes)	0.5	1.6	3.4	7.6	10.8	5.6	5.4	4.9	5.5	10.4	14.7	9.8	12.8	20.0	10.0
Ore grade (g/t)	3.32	2.84	2.65	2.70	3.06	3.71	3.99	4.55	6.88	11.67	14.80	16.38	17.23	18.06	19.13
Stripping ratio	1079	449	206	118	84	83	89	101	98	53	36	27	20	14	6

END OF EXAMINATION

UNIVERSITY OF ZAMBIA

UNIVERSITY EXAMINATION –AUG/SEPT 2017

MIN 5099 – MINERAL ECONOMICS & MANAGEMENT

INSTRUCTIONS: Answer Question One and any Three

DCF tables are attached at the end

TIME: 3 HOURS

TOTAL MARKS: 100

Question one

Exploration drilling has delineated copper reserves with a total tonnage of 16.560 million. Mineral development officers anticipate the project to operate for 345 days in a year. The variables below are indexed to the project:

Copper grade	0.75%
Combined recovery	95%
Operation cost	45% of annual sales
Product selling price	\$1,450/tonne
Daily extraction rate	12, 000 tonnes
Capital expenditure of the project	\$45 million
Corporate income tax	20%
Gross mineral royalty	5%
Discount rate	10%

Depreciation is on Straight Line Method (SLM)

Determine the acceptability of the project using the following economic measures

- (i) Net Present Value (NPV) [6 marks]
- (ii) Undiscounted payback period [4 marks]
- (iii) Profitability Index (PI) [4 marks]
- (iv) NPV at 28% [4 marks]
- (v) Internal rate of return (IRR) [4 marks]
- (vi) Explain the notable differences in the determination of NPV and PI [3 marks]

QUESTION TWO

- (a) Geologists and metallurgists are conducting a feasibility study on a development mineral project to be extracted for cement and agriculture feed. The estimated mineral reserve base for development mineral is 2,000,000 tonnes. The project overall capital cost is US\$2.9 million. Metallurgists' assessments of the plant indicated that two products after processing can be sold as given in the table below

Final product	Annual product tonnage	Product's sales price (US\$/tonne)
Cement feed	380,000	10.25
Agriculture feed	95,000	4.50
Total tonnage	475,000	
Plant recovery	95%	

- (i) Calculate the required mining rate (tonnage) for the mineral development needed to be fed in the plant to produce 475,000 tonnes of the final products without wastage and unnecessary stockpiling from the mine and the plant. **[4 marks]**
- (ii) Estimate the life of the project from mining perspective **[4 marks]**
- (iii) If the aggregated operation cost for producing the products is US\$6.70/tonne, evaluate the viability of this project (NPV and PI) at 10 discount rate. **[6 marks]**
- (iv) Discuss the mineral pricing mechanisms that could be ideal for this mineral development **[5 marks]**
- (b) Compute the depreciation charges with the relevant book values for this asset using SLM and SYD methods of depreciation if the salvage value is estimated at \$5million **[6 marks]**

Question three

- (a) Explain the concept of economic rent as applied to the mineral industry **[5 marks]**
- (b) A mining firm intends to appropriate monopoly rents based on the distinct commodity it produces. The firm's cost function is $C = 50 + Q^2$. The demand function is given as $Q = 40 - P$ where C and P are in US\$ and Q is in tonnes.
- (i) Estimate the profit maximizing price and quantity for the firm **[4 marks]**
- (ii) Calculate the monopolist's economic profit **[4 marks]**
- (iii) Determine the value of total revenue at sales maximization quantity **[4 marks]**

(iv) For the range of quantity (Q): 0,5,10,15,20, produce a table for Average Revenue (AR), Marginal Revenue (MR), Average Cost (AC) and Marginal Cost (MC)

[4 marks]

(v) Plot the curves for AR, MR, AC and MC showing the monopolist's economic profit region

[4 marks]

Question four

The market demand and supply equation for a mineral product is given by

$$Q_d = 3000 - 30P$$

$$Q_s = 1000 + 50P \text{ where } Q \text{ is the quantity and } P \text{ is the price in US\$}$$

(a) Estimate the price and quantity at the equilibrium point [3 marks]

(b) Calculate the price elasticity of demand and supply at equilibrium conditions

[4 marks]

(c) If an increase in industrialization resulted in the new demand equation

$$Q_d = 4200 - 30P, \text{ what is the new equilibrium price and quantity [3 marks]}$$

(d) Find the elasticity of demand at the new market conditions. What type of elasticity is obtained? [4 marks]

(e) The state enacts legislation that impose a price ceiling equivalent to the original equilibrium price [in part (a) above], explain whether this will create a *surplus* or *shortage* and estimate it in monetary terms. [3 marks]

(f) Calculate the level of surplus or shortage (in monetary value) due to this imposed legislation. [4 marks]

(g) Determine the percentage changes in equilibrium prices and quantities noted between part (a) and part (c) above. [4 marks]

Question five

(a) Explain valuation and the main methods applied to mineral deposit valuation [5 marks]

(b) An ore deposit planned for ore production by open pit method has 4.5 million tonnes at 2.50% copper grade. The plan is to extract the deposit to completion on equal annual production basis in 36 months. The general recovery for the project is 90%. The fixed cost per year are estimated at \$10,000,000 while variable cost are \$2/tonne. Market price for the commodity is estimated at \$450/tonne with annual growth of 4%.

Estimate

- (i) The annual profits for the project **[8 marks]**
- (ii) The monetary value to be attached to this project at 10% discount rate, based on valuation concepts, **[4 marks]**
- (c) A phosphate rich mineral project has a production function given by $Q = 50,000 KL$. Price of capital (K) is \$250/day while price for labour (L) is \$160/day. Q is phosphate ore produced in tonnes.
- Estimate the minimum cost of producing 500,000 tonnes of phosphate ore. **[8 marks]**

END OF EXAMINATION

Table A-1
Present Value of \$1: $PVIF_{k,n} = 1/(1+k)^n$

Period	1%	2%	3%	4%	5%	6%	7%	8%	9%	10%	12%	14%	15%	16%	18%	20%	24%	28%	32%	36%
1	.9901	.9804	.9709	.9615	.9524	.9434	.9346	.9259	.9174	.9091	.8929	.8772	.8696	.8621	.8475	.8333	.8085	.7813	.7576	.7353
2	.9803	.9612	.9426	.9246	.9070	.8900	.8734	.8573	.8417	.8264	.7972	.7695	.7611	.7432	.7182	.6944	.6504	.6104	.5739	.5407
3	.9706	.9423	.9151	.8890	.8638	.8396	.8163	.7930	.7722	.7513	.7118	.6750	.6555	.6407	.6086	.5787	.5245	.4768	.4348	.3975
4	.9610	.9238	.8885	.8548	.8227	.7921	.7629	.7350	.7084	.6830	.6355	.5921	.5718	.5523	.5158	.4823	.4230	.3725	.3294	.2923
5	.9515	.9057	.8626	.8219	.7835	.7473	.7130	.6806	.6499	.6209	.5674	.5194	.4972	.4761	.4371	.4019	.3411	.2910	.2495	.2149
6	.9420	.8880	.8375	.7903	.7462	.7050	.6663	.6302	.5963	.5645	.5066	.4556	.4323	.4104	.3704	.3349	.2751	.2274	.1890	.1580
7	.9327	.8706	.8131	.7599	.7107	.6651	.6227	.5835	.5470	.5132	.4523	.3996	.3759	.3538	.3139	.2791	.2218	.1776	.1432	.1162
8	.9235	.8535	.7894	.7307	.6768	.6274	.5820	.5403	.5019	.4655	.4039	.3506	.3269	.3050	.2660	.2326	.1789	.1388	.1065	.0828
9	.9143	.8368	.7664	.7026	.6446	.5919	.5439	.5002	.4604	.4241	.3606	.3075	.2843	.2630	.2255	.1938	.1443	.1084	.0822	.0624
10	.9053	.8203	.7441	.6736	.6139	.5584	.5083	.4632	.4224	.3855	.3220	.2697	.2472	.2267	.1911	.1615	.1164	.0847	.0623	.0462
11	.8963	.8043	.7224	.6496	.5847	.5268	.4751	.4289	.3875	.3505	.2875	.2366	.2149	.1954	.1619	.1346	.0938	.0662	.0472	.0340
12	.8874	.7895	.7014	.6246	.5568	.4970	.4440	.3971	.3555	.3186	.2567	.2076	.1869	.1685	.1372	.1122	.0757	.0517	.0357	.0250
13	.8787	.7730	.6810	.6006	.5303	.4688	.4150	.3677	.3262	.2897	.2292	.1821	.1625	.1452	.1163	.0935	.0610	.0404	.0271	.0184
14	.8700	.7579	.6611	.5775	.5051	.4423	.3878	.3405	.2992	.2633	.2046	.1597	.1413	.1252	.0985	.0779	.0492	.0316	.0205	.0135
15	.8613	.7430	.6419	.5553	.4810	.4173	.3624	.3152	.2745	.2394	.1827	.1401	.1229	.1079	.0835	.0649	.0397	.0247	.0155	.0099
16	.8528	.7284	.6232	.5339	.4581	.3936	.3387	.2919	.2519	.2176	.1631	.1229	.1069	.0930	.0708	.0541	.0320	.0193	.0118	.0073
17	.8444	.7142	.6050	.5134	.4363	.3714	.3166	.2703	.2311	.1978	.1456	.1078	.0929	.0802	.0600	.0451	.0258	.0150	.0089	.0054
18	.8360	.7002	.5874	.4936	.4155	.3503	.2959	.2502	.2120	.1799	.1300	.0946	.0808	.0691	.0508	.0376	.0208	.0118	.0068	.0039
19	.8277	.6864	.5703	.4746	.3957	.3305	.2765	.2317	.1945	.1635	.1161	.0829	.0703	.0596	.0431	.0313	.0188	.0092	.0051	.0029
20	.8195	.6730	.5537	.4564	.3769	.3118	.2584	.2145	.1784	.1486	.1037	.0728	.0611	.0514	.0365	.0261	.0135	.0072	.0039	.0021
21	.8114	.6598	.5375	.4388	.3589	.2942	.2415	.1997	.1637	.1351	.0892	.0658	.0531	.0443	.0309	.0217	.0109	.0056	.0029	.0016
22	.8034	.6468	.5219	.4220	.3418	.2775	.2257	.1839	.1482	.1202	.0738	.0560	.0462	.0382	.0262	.0181	.0088	.0044	.0022	.0012
23	.7954	.6342	.5067	.4057	.3256	.2618	.2109	.1703	.1378	.1117	.0738	.0491	.0402	.0329	.0222	.0151	.0071	.0034	.0017	.0008
24	.7876	.6217	.4919	.3901	.3101	.2470	.1971	.1577	.1264	.1015	.0659	.0431	.0349	.0284	.0188	.0126	.0057	.0027	.0013	.0006
25	.7798	.6095	.4776	.3751	.2953	.2330	.1842	.1460	.1160	.0923	.0588	.0378	.0304	.0245	.0160	.0105	.0046	.0021	.0010	.0005
26	.7720	.5976	.4637	.3607	.2812	.2198	.1722	.1352	.1064	.0839	.0525	.0331	.0264	.0211	.0135	.0087	.0037	.0016	.0007	.0003
27	.7644	.5889	.4502	.3468	.2678	.2074	.1609	.1252	.0976	.0763	.0469	.0291	.0230	.0182	.0115	.0073	.0030	.0013	.0006	.0002
28	.7568	.5744	.4371	.3335	.2551	.1956	.1504	.1159	.0895	.0693	.0419	.0255	.0200	.0157	.0097	.0061	.0024	.0010	.0004	.0002
29	.7493	.5631	.4243	.3207	.2429	.1846	.1406	.1073	.0822	.0630	.0374	.0224	.0174	.0135	.0082	.0051	.0020	.0008	.0003	.0001
30	.7419	.5521	.4120	.3083	.2314	.1741	.1314	.0994	.0754	.0573	.0334	.0196	.0151	.0116	.0070	.0042	.0016	.0006	.0002	.0001
35	.7059	.5000	.3554	.2534	.1813	.1301	.0937	.0676	.0490	.0356	.0189	.0102	.0075	.0055	.0030	.0017	.0005	.0002	.0001	.
40	.6717	.4529	.3086	.2083	.1420	.0972	.0688	.0460	.0318	.0221	.0107	.0053	.0037	.0026	.0013	.0007	.0002	.0001	.	.
45	.6391	.4127	.2644	.1712	.1120	.0727	.0488	.0313	.0217	.0133	.0061	.0027	.0019	.0013	.0006	.0003	.0001	.	.	.
50	.6080	.3715	.2281	.1407	.0872	.0543	.0339	.0213	.0134	.0085	.0035	.0014	.0009	.0006	.0003	.0001
55	.5785	.3365	.1968	.1157	.0683	.0406	.0242	.0145	.0087	.0053	.0020	.0007	.0005	.0003	.0001

*The factor is zero to four decimal places.

Copyright © 1984 The Dryden Press A Division of CBS College Publishing

Table A-2
Present Value of an Annuity of \$1 per Period
for n Periods:

$$PVIFA_{n,k} = \sum_{t=1}^n \frac{1}{(1+k)^t} = \frac{1 - \frac{1}{(1+k)^n}}{k}$$

Number of Periods	1%	2%	3%	4%	5%	6%	7%	8%	9%	10%	12%	14%	15%	16%	18%	20%	24%	28%	32%
1	0.9901	0.9804	0.9709	0.9615	0.9524	0.9434	0.9346	0.9259	0.9174	0.9091	0.8929	0.8772	0.8666	0.8621	0.8475	0.8333	0.8065	0.7813	0.7576
2	1.9704	1.9416	1.9135	1.8861	1.8594	1.8334	1.8080	1.7833	1.7591	1.7355	1.6901	1.6467	1.6237	1.6032	1.5656	1.5278	1.4568	1.3916	1.3315
3	2.9410	2.8839	2.8286	2.7751	2.7232	2.6730	2.6243	2.5771	2.5313	2.4869	2.4018	2.3216	2.2830	2.2469	2.1743	2.1065	1.9613	1.8284	1.7067
4	3.9020	3.8077	3.7171	3.6299	3.5460	3.4651	3.3872	3.3121	3.2397	3.1699	3.0373	2.9137	2.8550	2.7992	2.6901	2.5887	2.4043	2.2410	2.0957
5	4.8534	4.7135	4.5797	4.4518	4.3295	4.2124	4.1002	3.9927	3.8897	3.7908	3.6048	3.4331	3.3522	3.2743	3.1272	2.9905	2.7454	2.5220	2.3452
6	5.7955	5.6014	5.4172	5.2421	5.0757	4.9173	4.7665	4.6229	4.4859	4.3553	4.1114	3.8887	3.7945	3.6847	3.4976	3.3255	3.0205	2.7594	2.5342
7	6.7282	6.4720	6.2303	6.0021	5.7864	5.5824	5.3933	5.2064	5.0330	4.8664	4.5638	4.2887	4.1604	4.0386	3.8115	3.6046	3.2423	2.9570	2.6775
8	7.6517	7.3255	7.0197	6.7327	6.4632	6.2098	5.9713	5.7466	5.5348	5.3349	4.9676	4.6389	4.4873	4.3436	4.0776	3.8372	3.4212	3.0758	2.7660
9	8.5660	8.1622	7.7861	7.4353	7.1078	6.8017	6.5152	6.2469	5.9952	5.7590	5.3282	4.9464	4.7716	4.6035	4.3030	4.0310	3.5655	3.1842	2.8681
10	9.4713	8.9826	8.5302	8.1109	7.7217	7.3601	7.0236	6.7101	6.4177	6.1446	5.6502	5.2161	5.0188	4.8332	4.4941	4.1925	3.6819	3.2899	2.9304
11	10.3676	9.7868	9.2526	8.7605	8.3064	7.8869	7.4987	7.1390	6.8052	6.4951	5.9377	5.4527	5.2337	5.0286	4.6560	4.3271	3.7757	3.3351	2.9776
12	11.2551	10.5753	9.9540	9.3851	8.8633	8.3858	7.9427	7.5361	7.1607	6.8137	6.1944	5.6603	5.4206	5.1971	4.7932	4.4392	3.8514	3.3868	3.0133
13	12.1337	11.3484	10.6350	9.9856	9.3936	8.8527	8.3577	7.9028	7.4869	7.1034	6.4235	5.8424	5.5831	5.3423	4.9095	4.5327	3.9124	3.4272	3.0404
14	13.0037	12.1082	11.2961	10.5631	9.8966	9.2950	8.7455	8.2442	7.7882	7.3667	6.6282	6.0021	5.7245	5.4675	5.0081	4.6106	3.9616	3.4587	3.0609
15	13.8651	12.8493	11.9379	11.1184	10.3797	9.7122	9.1079	8.5593	8.0607	7.6081	6.8109	6.1422	5.8474	5.5755	5.0916	4.6755	4.0013	3.4834	3.0784
16	14.7179	13.5777	12.5611	11.6523	10.8378	10.1059	9.4666	8.8514	8.3126	7.8237	6.9740	6.2651	5.9542	5.6685	5.1624	4.7298	4.0333	3.5026	3.0882
17	15.5623	14.2919	13.1681	12.1657	11.2741	10.4773	9.7832	9.1216	8.5436	8.0216	7.1196	6.3729	6.0472	5.7487	5.2223	4.7746	4.0591	3.5177	3.0971
18	16.3983	14.9920	13.7353	12.6593	11.6896	10.8276	10.0591	9.3719	8.7379	8.2014	7.2487	6.4674	6.1280	5.8178	5.2732	4.8122	4.0799	3.5294	3.1039
19	17.2280	15.6785	14.3238	13.1339	12.0853	11.1581	10.3356	9.6036	8.9501	8.3649	7.3658	6.5504	6.1982	5.8775	5.3182	4.8435	4.0867	3.5386	3.1090
20	18.0486	16.3514	14.8775	13.5903	12.4622	11.4689	10.5940	9.8181	9.1079	8.5593	7.4694	6.6231	6.2593	5.9288	5.3527	4.8698	4.1103	3.5458	3.1129
21	18.8570	17.0112	15.4150	14.0292	12.8212	11.7641	10.8355	10.0168	9.2922	8.6487	7.5620	6.6870	6.3125	5.9731	5.3837	4.8913	4.1212	3.5514	3.1158
22	19.6604	17.6590	15.9369	14.4511	13.1630	12.0416	11.0612	10.2007	9.4424	8.7715	7.6446	6.7429	6.3587	6.0113	5.4099	4.9094	4.1300	3.5558	3.1180
23	20.4568	18.2922	16.4436	14.8588	13.4868	12.5034	11.2722	10.3711	9.5802	8.8832	7.7184	6.7921	6.3988	6.0442	5.4321	4.9245	4.1371	3.5592	3.1197
24	21.2434	18.9139	16.9355	15.2470	13.7986	12.9504	11.4693	10.5288	9.7066	9.0847	7.7843	6.8331	6.4338	6.0726	5.4509	4.9371	4.1428	3.5619	3.1210
25	22.0232	19.5235	17.4131	15.6221	14.0939	12.7834	11.6536	10.6748	9.8226	9.0770	7.8431	6.8729	6.4641	6.0971	5.4669	4.9476	4.1474	3.5640	3.1220
26	22.7952	20.1210	17.8768	15.9828	14.3752	13.0032	11.8258	10.8100	9.9290	9.1609	7.8957	6.9061	6.4906	6.1182	5.4804	4.9563	4.1511	3.5656	3.1227
27	23.5596	20.7089	18.3270	16.3296	14.6430	13.2105	11.9867	10.9266	10.0266	9.2372	7.9426	6.9332	6.5135	6.1364	5.4919	4.9636	4.1542	3.5669	3.1233
28	24.3164	21.2813	18.7641	16.6691	14.8981	13.4062	12.1371	10.9511	10.1161	9.3066	7.9844	6.9607	6.5335	6.1520	5.5016	4.9697	4.1566	3.5679	3.1237
29	25.0658	21.8444	19.1885	16.9837	15.1411	13.5897	12.2777	10.9763	10.1983	9.4289	8.0218	6.9802	6.5509	6.1666	5.5098	4.9747	4.1585	3.5683	3.1240
30	25.8077	22.3966	19.6004	17.2920	15.3725	13.7648	12.4080	10.9937	10.2787	9.4869	8.0552	7.0027	6.5660	6.1772	5.5168	4.9789	4.1601	3.5683	3.1242
35	29.4088	24.8968	21.4872	18.6846	16.3742	14.8982	12.9477	11.6546	10.5668	9.6442	8.1755	7.0700	6.6166	6.2153	5.5386	4.9915	4.1644	3.5708	3.1248
40	32.8847	27.3655	23.1148	19.7928	17.1751	15.6453	13.3317	11.8254	10.7454	9.7791	8.2498	7.1050	6.6543	6.2335	5.5482	4.9966	4.1659	3.5712	3.1250
45	36.0945	29.4682	24.5187	20.7228	17.7741	16.4558	13.8055	12.1084	10.8812	9.8628	8.2925	7.1222	6.6895	6.2463	5.5523	4.9966	4.1664	3.5714	3.1250
50	39.1961	31.4236	25.5798	21.4822	18.2859	17.0191	13.8007	12.3335	10.9617	9.9148	8.3045	7.1227	6.6895	6.2463	5.5541	4.9995	4.1666	3.5714	3.1250
55	42.1472	33.1748	26.7744	22.1086	18.6336	18.9505	13.9399	12.3186	11.0140	9.9471	8.3170	7.1376	6.6936	6.2482	5.5549	4.9998	4.1666	3.5714	3.1250

col

UNIVERSITY OF ZAMBIA

UNIVERSITY EXAMINATION - SEPTEMBER 2017

MM 5139- SPECIAL TOPICS IN MINERAL PROCESSING

Time : THREE hours
Answer: FIVE questions
All questions carry equal marks

- Q1. An ore containing 3% Cu in the form of chalcopyrite (CuFeS_2), the remainder being predominately siliceous gangue (s.g 2.7). The ore is crushed to -12mm and sampled before being further treated. The output from the crusher is fed to storage bins via a conveyor system at an average rate of 100 tonnes per hour. Assuming that the crushed material is thoroughly mixed, determine the limit of error (at 99% confidence limited) in the Cu assay introduced by taking a 1kg sample from the conveyor at intervals of 30 minutes. A test of the ore showed that the maximum Cu content of any piece is 10% Cu. The specific gravity of chalcopyrite is 4.2. Take the shape factor and size factor as 0.5 and 0.25 respectively.
- Q2. (a) What are the advantages of using particle size distribution functions over the other methods of presenting sizing data?
- (b) What is the general equation of particle size distribution function. Outline the significance of the parameters with reference to the Guadin-Schulmann and Rosin-Rammler functions. Show the relationship between the two functions.
- (c) A particle size distribution of the ore is known to follow the G.S. function with 90% and 50% of the particle being less than 1mm and 0.5mm respectively. What is the weight percent between $10\ \mu\text{m}$ and $20\ \mu\text{m}$?
- Q3. (a) Explain how an electrical double layer may be formed when minerals are put in a solution:
- (b) What do you understand by the following terms?
- Electrophoresis
 - Streaming potential
 - Electro osmosis
 - Sedimentation Potential

How can you measure the first two and give detailed explanation of how Electrophoresis will lead to establishing the zeta potentials and explain how this may be use in the separation of different minerals.

- Q4. What is the purpose of particle size reduction in mineral processing?

- (i) Give the various definitions of “Reduction Ratio” and identify the most important definitions.
- (ii) In Energy-Size reduction relationships as used in the design of comminution equipment, empirical “laws” are normally used. Name these laws and explain on which basis each one is used. Using a generalised equation derive each one of them.
- (iii) What do you understand by the term “Bond index”?

Q5. (a) “Only regular geometrical shapes can have their sizes conveniently qualified”. Discuss the implications of this statement with regards to:

- (i) The various definition of “size”
- (ii) Applications of these definitions size.

(b) Discuss the principle involved in incremental methods and show how the data obtained may be useful.

(c) Describe the Andreassen pipette and the interpretation/calculation of results. What are the main disadvantages of this apparatus?

Q6. The following data refer to the adsorption of Nitrogen on 0.92 g of a sample of silica gel at 77 K being the pressure and V the Volume adsorbed:

p/Kpa	3.7	8.5	15.2	23.6	31.5	38.2	46.1	54.8
Vol cm ³ (s.t.p.) g ⁻¹	82	106	124	142	157	173	196	227

Use the BET equation to calculate a specific surface area for silica gel sample taking the molecular surface area of the adsorbed Nitrogen at monolayer coverage as $16.2 \times 10^{-20} \text{m}^2$.

BET equation may be written as:

$$\frac{p}{v(p_o - p)} = \frac{1}{v_m C} + \frac{(C - 1)}{v_m C} \left(\frac{p}{p_o} \right)$$

END OF MET 5139 EXAMINATION AND GOOD LUCK.