

**CAPABILITY OF ZAMBIAN INDUSTRIES TO MANUFACTURE  
GRID-SCALE WIND TURBINE BLADES AND TOWERS**

**by**

**Amos Banda**

A dissertation submitted to the University of Zambia in partial fulfilment of the requirements of the degree of Master of Engineering in Renewable Energy Engineering

**The University of Zambia**

**Lusaka**

**2020**

## **COPYRIGHT DECLARATION**

All rights reserved. No part of this work may be reproduced without prior written consent from the author or The University of Zambia.

**DECLARATION**

I, **Amos Banda** do hereby declare that the contents of the dissertation being submitted herein are my original work and they have not been previously submitted to any University for the award of a degree or any other qualification.

**Signature**..... **Date**.....

## CERTIFICATE OF APPROVAL

This dissertation submitted by, **Amos Banda** is approved as fulfilling the requirements for the award of the degree of Masters of Engineering in Renewable Energy Engineering at the University of Zambia.

**Examiner 1:** \_\_\_\_\_ **Sign:** \_\_\_\_\_ **Date:** \_\_\_\_\_

**Examiner 2:** \_\_\_\_\_ **Sign:** \_\_\_\_\_ **Date:** \_\_\_\_\_

**Examiner 3:** \_\_\_\_\_ **Sign:** \_\_\_\_\_ **Date:** \_\_\_\_\_

**Chairperson, Board of Examiners**

**Name:** \_\_\_\_\_ **Sign:** \_\_\_\_\_ **Date:** \_\_\_\_\_

**Supervisor:** \_\_\_\_\_ **Sign:** \_\_\_\_\_ **Date:** \_\_\_\_\_

## ABSTRACT

The Zambian electricity grid system has been dominated by hydropower at 96 %, 2.1 % thermal and 1.7 % renewable (Kaluminiana, n.d.). During the 2014 - 2015 rainy season, Zambia received very low rains which led to reduced electricity production at the two major power plants. In the light of this situation, there was a push towards diversification in the power generation mix to achieve a more resilient energy system. This quest for diversification has led to the inception of grid-scale wind power feasibility studies at ten sites distributed around the country. These feasibility studies were aimed at establishing the availability of the wind resource for grid-scale power generation. This will lead to the development of the wind power industry in Zambia. However, these studies did not investigate the capability of local support industries, this research intends to bridge that knowledge gap. The purpose of this study was to investigate and profile the capability of Zambian industries to manufacture wind turbine (WT) blades and towers. The study used a mixed-method approach to collect data, both qualitative and quantitative approaches were employed in a complementary manner. The population of Zambian industries was collected from the Zambia Association of Manufacturers (ZAM) based on the 2018 registered members. This data was used to define the population for the study. The population was arranged in three strata whose characteristics are homogeneous within each stratum. Due to the low population, the study was conducted on the whole population. The quantitative data was collected from each stratum using a quantitative data collection tool developed for each stratum and analysed. A review of the wind resource assessment projects has demonstrated that there are Class III and Class IV sites in certain parts of Zambia. The results from this study have revealed that on an as-is basis there are no companies in Zambia which can manufacture WT blades and towers.

Keywords: wind-energy, wind-turbine-blades, wind-turbine-towers, manufacturing, Zambia.

## **DEDICATION**

This work is sincerely dedicated to my wife Norah and my children Maria, Amos and Emma who shared with me the trials and tribulations during my studies. I thank them whole heartedly for their moral support and understanding when I could not avail myself as much as I should have done during the period of my studies. To the rest of my family and friends I thank you for the support rendered during the course of my studies it gave me the strength to keep moving forward. To my late grandparents and parents, you may not be here but you are the giants on whose shoulders I stand. To you all, this is the reward of your endurance.

## **ACKNOWLEDGEMENTS**

I owe a deep and sincere debt of gratitude to my supervisor Dr H. M. Mwenda, for his continuous and constructive input; Technology Development and Advisory Unit (TDAU) of the University of Zambia (UNZA), for financial and logistical support towards this study. Their valuable suggestions and professional guidance enriched this study at every stage.

Further, I would like to express my heartfelt appreciation to all the respondents who took part in this study, without their valuable information this study would not have been a success.

## TABLE OF CONTENTS

DECLARATION.....	i
CERTIFICATE OF APPROVAL .....	iii
ABSTRACT .....	iv
DEDICATION.....	v
ACKNOWLEDGEMENTS .....	vi
LIST OF TABLES .....	ix
LIST OF FIGURES .....	x
LIST OF ABBREVIATIONS .....	xi
<b>CHAPTER ONE: INTRODUCTION .....</b>	<b>1</b>
<b>1.1 Background .....</b>	<b>1</b>
<b>1.2 Problem Statement.....</b>	<b>2</b>
<b>1.3 Main Objective .....</b>	<b>2</b>
<b>1.4 Specific Objectives .....</b>	<b>2</b>
<b>1.5 Research Questions .....</b>	<b>2</b>
<b>CHAPTER TWO: LITERATURE REVIEW .....</b>	<b>3</b>
<b>2.1 Technological Development of Wind Turbines .....</b>	<b>3</b>
<b>2.2 IEC Wind Turbine Classes.....</b>	<b>4</b>
<b>2.3 Status of Wind Power in Zambia.....</b>	<b>5</b>
<b>2.4 Wind Turbine Components and Manufacture.....</b>	<b>15</b>
<b>2.4.1 Blade.....</b>	<b>17</b>
<b>2.4.2 Tower .....</b>	<b>24</b>
<b>2.5 Installation of Wind Turbines.....</b>	<b>32</b>
<b>CHAPTER THREE: METHODOLOGY OF THE STUDY .....</b>	<b>35</b>
<b>3.1 Research Design .....</b>	<b>35</b>
<b>3.2 Study Population and Study Sample .....</b>	<b>35</b>
<b>3.3 Data Collection .....</b>	<b>36</b>
<b>3.4 Data Analysis.....</b>	<b>37</b>
<b>CHAPTER FOUR: RESULTS/FINDINGS.....</b>	<b>38</b>
<b>4.1 Review of Grid-Scale Wind Power Potential.....</b>	<b>38</b>
<b>4.1.1 Grid-Scale Wind Resource Potential in Zambia .....</b>	<b>38</b>
<b>4.1.2 Reference WT for Zambia .....</b>	<b>39</b>
<b>4.1.3 Reference Manufacturing Facilities .....</b>	<b>40</b>
<b>4.2 WT Blade Manufacturing .....</b>	<b>42</b>
<b>4.2.1 Steel Tower Manufacturing .....</b>	<b>45</b>
<b>4.2.2 Steel Tubular Tower Manufacturing .....</b>	<b>47</b>

4.2.3	Steel Lattice Tower Manufacturing .....	49
4.2.4	Pre-Fabricated Concrete Sections .....	51
4.3	Priority Gap Analysis .....	51
<b>CHAPTER FIVE: DISCUSSION.....</b>		<b>54</b>
5.1	Wind Potential for Wind Power Development in Zambia .....	54
5.2	Capacity of Zambian Manufacturing Industries to Manufacture Grid-Scale Wind Turbine Blades and Towers.....	55
5.2.1	WT Blade Manufacturing .....	55
5.2.2	Tower Manufacturing.....	56
5.3	Gaps to be Prioritised in Order to Enhance the Local Industry Capacity .....	58
<b>CHAPTER SIX: CONCLUSION AND RECOMMENDATIONS.....</b>		<b>60</b>
6.1	Conclusion .....	60
6.2	Recommendations .....	61
<b>REFERENCES.....</b>		<b>63</b>
<b>APPENDIX I: PAPER PUBLISHED IN THE 4<sup>TH</sup> AFRICA ENGINEERING CONFERENCE BOOK OF PROCEEDINGS.....</b>		<b>67</b>
<b>APPENDIX II: QUESTIONNAIRE FOR WIND TURBINE BLADE MANUFACTURING.....</b>		<b>77</b>
<b>APPENDIX III: QUESTIONNAIRE FOR STEEL TOWER MANUFACTURING... </b>		<b>80</b>

## LIST OF TABLES

<b>Table 1:</b> Wind Turbine Classes (Eanest & Wizelius, 2011). .....	5
<b>Table 2:</b> Met Mast Summary for Eight Wind Resource Assessment Sites (DNV-GL, 2018).9	9
<b>Table 3:</b> Summary of Annual Average Wind Speeds at 80m and 130m (DNV-GL, 2018)..	10
<b>Table 4:</b> Summary of the KGRTC mast.....	11
<b>Table 5:</b> Summary of Wind Data from KGRTC Mast (RINA, 2018).....	11
<b>Table 6:</b> Summary of Kasomalunga Mast.....	12
<b>Table 7:</b> Summary of Wind Data from Kasomalunga Mast (TDAU, 2018). .....	14
<b>Table 8:</b> Summary of Annual Average Wind Speeds at Ten Sites in Zambia. ....	38
<b>Table 9:</b> Specifications for a Reference WT for Zambia. ....	39
<b>Table 10:</b> General Specifications for Reference WT Blade Manufacturing Facilities. ....	40
<b>Table 11:</b> General Specifications for Reference WT Steel Tubular Manufacturing Facilities. .....	41
<b>Table 12:</b> General Specifications for Reference WT Lattice Tower Manufacturing Facilities. .....	41
<b>Table 13:</b> General Specifications for Reference WT Concrete Tower Manufacturing Facilities. ....	42
<b>Table 14:</b> Basic Survey Information on WT Blade Manufacturing. ....	42
<b>Table 15:</b> Available Infrastructure on Polymer Company Premises. ....	44
<b>Table 16:</b> Available GFRP Surface Finishing Tools and Skills. ....	45
<b>Table 17:</b> Basic Survey Information. ....	45
<b>Table 18:</b> Available Infrastructure at Mechanical Engineering Plants/Workshops .....	46
<b>Table 19:</b> Available Equipment To Handle Steel Plates of 25 mm Thickness. ....	49
<b>Table 20:</b> Available Equipment to Handle Angle Bars Measuring 150 mm by 150mm. ....	51
<b>Table 21:</b> Basic Survey Information on Pre-Fabricated Concrete Towers. ....	51
<b>Table 22:</b> Basic Survey Information Gap Analysis.....	51

## LIST OF FIGURES

<b>Figure 1:</b> Growth in the Size of Wind Turbines since 1985 (IRENA, 2012).....	4
<b>Figure 2:</b> Global Cumulative Installed Capacity 2001-2016 (GWEC, 2017).....	4
<b>Figure 3:</b> A 10 m Metmast in Samfya Installed Under the SASSCAL Program .....	6
<b>Figure 4:</b> Global Atlas Showing Wind Speed Distribution in Zambia (IRENA, 2014) .....	8
<b>Figure 5:</b> The NRG 60 m Mast Installed at Kasomalunga in Luapula.....	13
<b>Figure 6:</b> Components of a Wind Turbine (Newen, n.d.) .....	16
<b>Figure 7:</b> The Working Principle of an Aerofoil (NASA, n.d.) .....	17
<b>Figure 8:</b> Force and Wind Vectors on a Blade Element According to the BEM .....	19
<b>Figure 9:</b> Schematic of a Typical Blade Section (Mishnaevsky Jr, et al., 2017) .....	21
<b>Figure 10:</b> Moulds for Manufacturing WT Blades (Vries, 2011) .....	22
<b>Figure 11:</b> Painting Robots for WT blades (Sainz, 2015).....	23
<b>Figure 12:</b> A Finished LM Blade Ready for Shipping (LM Wind Power, n.d.) .....	24
<b>Figure 13:</b> Ribbed and Cylindrical Steel Tubular Conical Towers.....	25
<b>Figure 14:</b> The Fuhrländer Wind Turbine with a 160 m Hub Height Lattice Tower. (Esser- Systems, 2018).....	27
<b>Figure 15:</b> A Wind Turbine with a Concrete Tower. ....	29
<b>Figure 16:</b> WTs with Hybrid Concrete-Steel Tower and Lattice-Steel Tower. ....	30
<b>Figure 17:</b> Transportation of an 83.5 m long WT Blade from Danish SSP Technology (SSP- Technology, 2017) .....	33
<b>Figure 18:</b> Transportation of a WT Tower Section by Ace Doran Haulage and Rigging (Ace-Doran, 2017) .....	33
<b>Figure 19:</b> Wind Turbine Installation (SSP-Technology, 2017).....	34
<b>Figure 20:</b> Percentage of Companies which can Manufacture GFRP Products.....	43
<b>Figure 21:</b> Total Premise Area Occupied by Companies.....	43
<b>Figure 22:</b> Companies with Adequate Mould Space .....	44
<b>Figure 23:</b> Companies which conduct GFRP surface finishing operations .....	45
<b>Figure 24:</b> Total Area Occupied by Mechanical Engineering Plants/Workshops .....	46
<b>Figure 25:</b> Mechanical Engineering Plants/Workshops Which Can Cut 25 mm steel Plates	47
<b>Figure 26:</b> Mechanical Engineering Plants/Workshops Which Can Weld 25 mm Steel Plates .....	48
<b>Figure 27:</b> Mechanical Engineering Plants/Workshops Which Can Conduct Surface Finishing on Steel Surfaces.....	48
<b>Figure 28:</b> Mechanical Engineering Plants/Workshops Which Can Straighten 150 mm x 150 mm Angle Bars .....	49
<b>Figure 29:</b> Mechanical Engineering Plants/Workshops Which Can Cut 150 mm x 150 mm Angle Bars .....	50
<b>Figure 30:</b> Mechanical Engineering Plants/Workshops Which Can Punch Holes Into 150 mm x 150 mm Angle Bars .....	50
<b>Figure 31:</b> Gaps in The Participation of Local Companies In WT Manufacturing .....	52

## LIST OF ABBREVIATIONS

AEP	Annual Energy Production
BEM	Blade Element Momentum
CNC	Computer Numeric Control
CAPEX	Capital Expenditure
DFMA	Design for Manufacture and Assembly
DoE	Department of Energy
EYA	Energy Yield Analysis
GFRP	Grass-Fibre Reinforced Polymer
HAWT	Horizontal Axis Wind Turbine
IEC	International Electro-Technical Commission
IRENA	International Renewable Energy Agency
KGRTC	Kafue Gorge Regional Training Centre
LCoE	Levelized Cost of Energy
MWT	Megawatt Wind Turbine
NACA	National Advisory Committee for Aeronautics
NC	Numeric Control
REA	Rural Electrification Authority
RINA	Registro Italiano Navale
SASSCAL	Southern African Science Service Centre for Climate Change and Adaptive Land Management
TDAU	Technology Development and Advisory Unit
VAWT	Vertical Axis Wind Turbine
WT	Wind Turbine
ZAM	Zambia Association Manufacturers
ZMD	Zambia Meteorological Department

## **CHAPTER ONE: INTRODUCTION**

This chapter introduces the research, it gives the background and states the problem statement of the research. The chapter further states the purpose of the study as well as the objectives and lists the research questions which the study intended to answer.

### **1.1 Background**

The Zambian electricity grid system has been dominated by hydropower at 96 %, 2.1 % thermal and 1.7 % renewable (Kaluminiana, n.d.). The renewables only comprise of solar and small hydro-power plants. During the 2014 - 2015 rainy season, Zambia received very low rainfall which led to reduced electricity production at the two major power plants namely Kafue Gorge Hydro-Power Plant and Kariba North Bank Hydro-Power Plant. This led to massive load-shedding in an attempt to manage the insufficient power being produced. In light of this situation, there was a push towards diversification in the power generation mix.

The quest to diversify the power generation mix has led to the commissioning of several power projects such the Maamba Thermal Power Plant, Grid-scale solar plants and several hydro power plants. This quest further led to the inception of grid-scale wind power feasibility studies at ten sites distributed around the country. These feasibility studies intend to establish the potential of wind resource for grid-scale power generation in Zambia, which may lead to wind power development.

In as much as the findings from the above studies are critical, they merely provided a starting point for wind power development. In order to operate in a sustainable manner, the wind power industry depends on support industries. These industries are from diverse sectors such as manufacturing, haulage and service. A strong local support industry is cardinal in establishing a sustainable environment for wind power development and growth. It further attracts the participation of big WT suppliers in the local and regional markets; Suppliers tend to position themselves in specific market segments in order to preserve their competitive advantages and meet local requirements (The DTI, SA, 2012).

This research intended to bridge the gap that had not been addressed by the feasibility studies mentioned above. The lack of information on the support industry makes it difficult for private sector participation in the industry as the risks will be high.

## **1.2 Problem Statement**

There are studies that have been conducted on assessing and validating the wind resource potential for Zambia, however there are no studies that have been undertaken to establish the capability of Zambian industries to manufacture WT blades and towers, this is the knowledge gap that exist and needs to be addressed in order to establish the full potential of the wind power industry in Zambia.

## **1.3 Main Objective**

The main objective of this research was to investigate and profile the capability of Zambian industries to manufacture grid-scale wind turbine blades and towers.

## **1.4 Specific Objectives**

The specific objectives of the project are;

- a) To review the wind potential for grid-scale wind power development in Zambia;
- b) To assess the capacity of Zambian industries to manufacture WT blades and towers;
- c) To identify pertinent gaps to be prioritised in order to enhance the local industry capacity;

## **1.5 Research Questions**

The following are the research questions of this study;

- a) What are the average wind speeds at selected potential sites?
- b) What are the specifications for a reference WT for the Zambian wind regime?
- c) Does the Zambian polymer industry have adequate space, equipment and skills to manufacture WT blades?
- d) Does the Zambian production engineering industry have adequate space, equipment and skills to manufacture WT steel towers?
- e) Does the Zambian concrete pre-cast industry have adequate space, equipment and skills to manufacture WT pre-cast concrete towers?
- f) What gaps limit Zambian industries to support local and regional wind power development?

## **CHAPTER TWO: LITERATURE REVIEW**

This chapter highlights the literature which others have written about wind power development and WT components manufacturing. This chapter focused on the latest wind power developments in Zambia as revealed by the current feasibility studies being conducted. Further, various industry practice in WT manufacturing technologies were thoroughly studied.

### **2.1 Technological Development of Wind Turbines**

Man has been using wind energy for mechanical work from time immemorial. Exactly how long man has known how to utilize wind for work is unknown, but some kinds of windmills were probably used in China and Japan some 3,000 years ago (Wizelius, 2009). The early windmills were made from locally available materials and the mechanical work produced was used to directly run equipment such as grindstones and water pumps.

In the early 1980s, WTs were small with capacities of 30 to 55 kW, the capacities of WTs has been doubling approximately in almost every four years (Enerst, 2014). The large WTs with capacities of 600 to 800 kW with stall control dominated the wind power industry in the 1990s. The late 1990s saw the introduction of another class of WTs called Megawatt Wind Turbines (MWT) with capacities in Megawatts. Within the Megawatt class, there is another class with far much bigger capacities greater than 2 MW. The largest WT currently in operation is the Vistas V164 with a capacity of 8 MW. The V164 WT can reach a rated power of 9 MW depending on specific site conditions (Vestas, 2017). The V164 has an overall height of 195 m, a diameter of 164 m and is for offshore use only. Figure 1 shows the growth in size of WTs over the years and a comparison to the largest aeroplane wingspan.

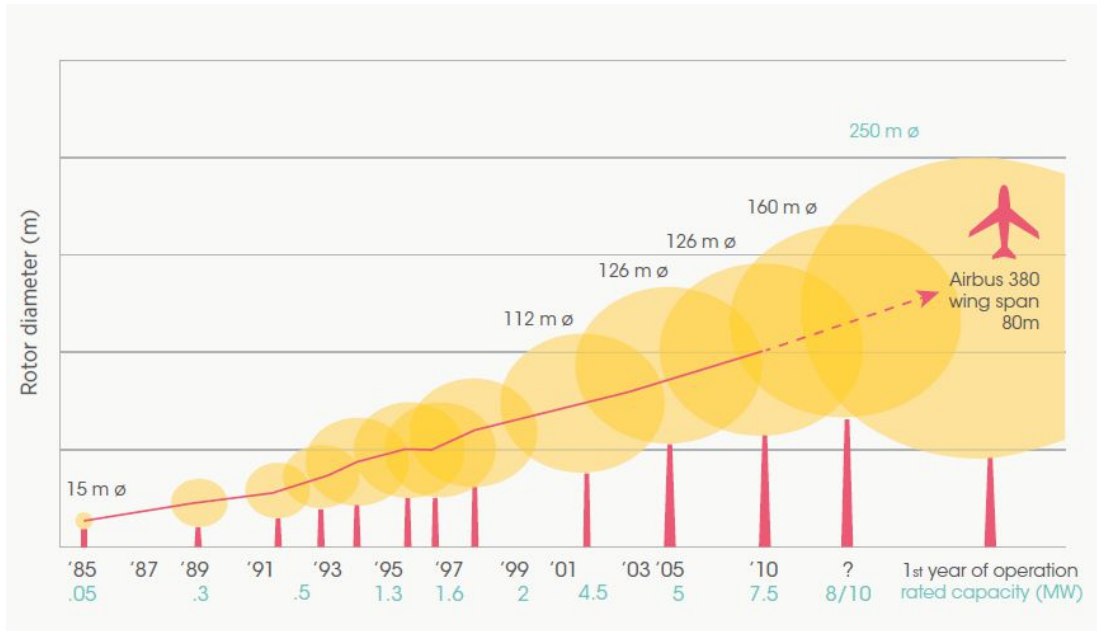

**Figure 1:** Growth in the Size of Wind Turbines since 1985 (IRENA, 2012)

The installed capacity of WTs has been growing extremely fast and is expected to continue in the coming decades as shown in Figure 2.

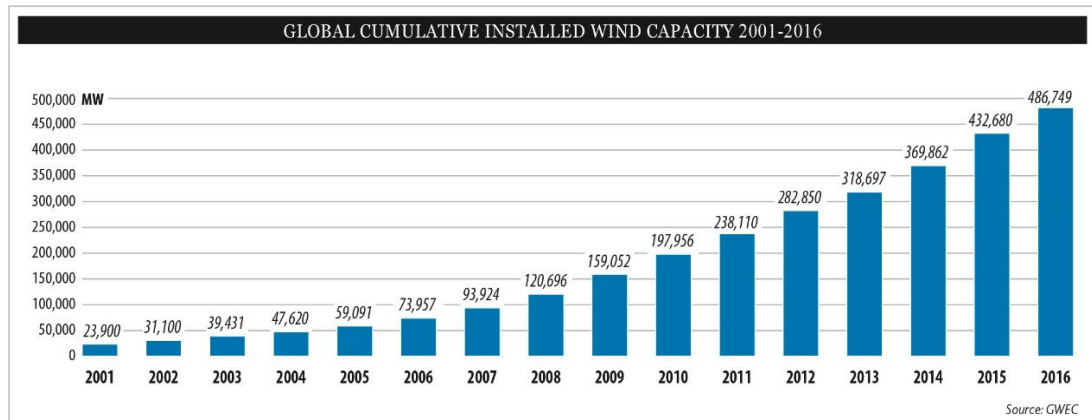

**Figure 2:** Global Cumulative Installed Capacity 2001-2016 (GWEC, 2017)

Figure 2 shows that the cumulative installed capacity stood at 486,749 MW at the end of 2016 compared to 23,900 MW in 2001. This shows that wind power is one of the fastest growing renewable energy sources in the world. There were 314,000 WTs spinning around the world at the end of 2015 (GWEC, 2017).

## 2.2 IEC Wind Turbine Classes

A WT operates on a reverse principle of a fan in that it uses the kinetic energy from the wind to turn the blades around a rotor. The rotor is connected to the main shaft, which spins a generator to create electricity. WTs come in different sizes and classes,

the International Electro-Technical Commission (IEC) has established wind turbine classes to be applied for standardization and certification of WTs. These classes are numbered from Class I for highest winds and Class IV for sites with very low winds, refer to Table 1.

**Table 1:** Wind Turbine Classes (*Eanest & Wizelius, 2011*).

	Wind Turbine Classes				
	I	II	III	IV	S
$V_{ref}$ (m/s)	50	42.5	37.5	30	Values to be specified by the designer
$V_{av}$ (m/s)	10	8.5	7.5	6	
$A_{/15}$	0.18	0.18	0.18	0.18	
$a$	2	2	2	2	
$B_{/15}$	0.16	0.16	0.16	0.16	
$a$	3	3	3	3	

*Note: the values apply at hub height and ‘A’ designates higher turbulence, ‘B’ designates lower turbulence. The subscript ‘/15’ is the turbulence intensity at 15 m/s, ‘a’ is the slope parameter in the Normal Turbulence Model equation.*

Table 1 has become handy for both turbine manufacturers and wind farm developers with regard to types of turbines. For example, for a site with very low average wind speeds of 6 m/s, it makes economic sense to install Class IV wind turbines which have low average operating speeds. In addition to wind speeds, the table provides the turbulence survivability of a turbine in each class at a turbulence intensity of 15 m/s. The Class S WTs have customized parameters to suit a site that does not fit in Classes I to IV.

### 2.3 Status of Wind Power in Zambia

Zambia is a new market to wind power and there are currently no installed wind farms. The major challenge that has faced wind power development in Zambia is the lack of appropriate and industry standard wind data. The available wind data has been recorded for over 30 years and was intended for agricultural and weather forecasting purposes. The Zambia Meteorological Department (ZMD) has been responsible for recording and analysing the wind data. This data was mainly recorded at 2 m heights with later sites measuring at 10 m heights such as the one in Figure 3 installed under the Southern African Science Service Centre for Climate Change and Adaptive Land Management (SASSCAL).



**Figure 3:** A 10 m Metmast in Samfya Installed Under the SASSCAL Program

The later equipment provides better wind data quality compared to the older analogy/manual systems. The later systems are fully automated and record data every 10 minutes on a daily basis. This data is remotely accessed via internet. There are 10 of these systems installed around the country. Wind data collected at 10 m above the ground indicate speeds between 0.1 to 3.5 m/s with an annual average of 2.5 m/s (ZDA, 2014). It should be noted that the wind data referred to was not intended for grid-scale wind power generation. It can therefore be deduced that the methods used to obtain and analyse the wind data do not conform to the wind power industry practice. This data cannot be exclusively used to determine whether the wind resource is adequate for grid-scale wind power generation or not, however, it can be used to locate potential sites for detailed feasibility studies.

In the absence of adequate ground measured wind data, a number of meta-data sets can be used to establish the wind resource for an area of interest. These data sets are generated from satellite and wind data from nearby meteorological stations. The IRENA Global Wind Atlas is a wind map which was generated using meta-data. The IRENA Global Wind Atlas shown in Figure 4 indicates the presence of some areas within Zambia with annual wind speeds of around 7 m/s at 80 m heights.

The Wind Atlas is generated using wind data obtained from satellite and nearby meteorological stations, however, the uncertainty can be as high as 10 %, and this will impact the accuracy of Annual Energy Production (AEP) estimation, overall risk and funding. On-site measurement can reduce uncertainty by more than 50 % over models derived from satellite data alone (NRG Systems, 2018). It is against this background that the Department of Energy (DoE) and the World Bank commissioned a project to validate the national wind atlas. The final, validated, peer reviewed output from this project will be the Zambia Wind Atlas, which will be published by the World Bank once the project is completed (DNV-GL, 2016).

This exercise involved selection of suitable sites around the country. The sites with the highest wind resource potential were given highest priority. The selection of the sites was based on the industry practice of taking into consideration various factors such as accessibility, grid connection, environmental issues, etc. At the end of a rigorous selection process, eight sites were selected as shown in Table 2.

Wind resource measurements have been recorded at the eight sites using met masts with measurements taken from November 2016 to January 2018 (DNV-GL, 2018). Note that at the time of this study, data recording was still on-going, the captured period was to facilitate an interim data analysis. Wind data was recorded every ten minutes on a daily basis. This data was run through a software to generate various statistical outputs such as annual average wind speed and frequency wind speed distribution for the measuring period. The annual average wind speed is particularly important as it gives the first indicator of the site's resource potential and can be used to decide whether to continue investigating the site or not. The software was further used to apply long term adjustments to the site measured data so as to predict the annual average wind speed for the project life. To obtain a refined picture of the resource, the wind speeds were extrapolated to turbine hub height.

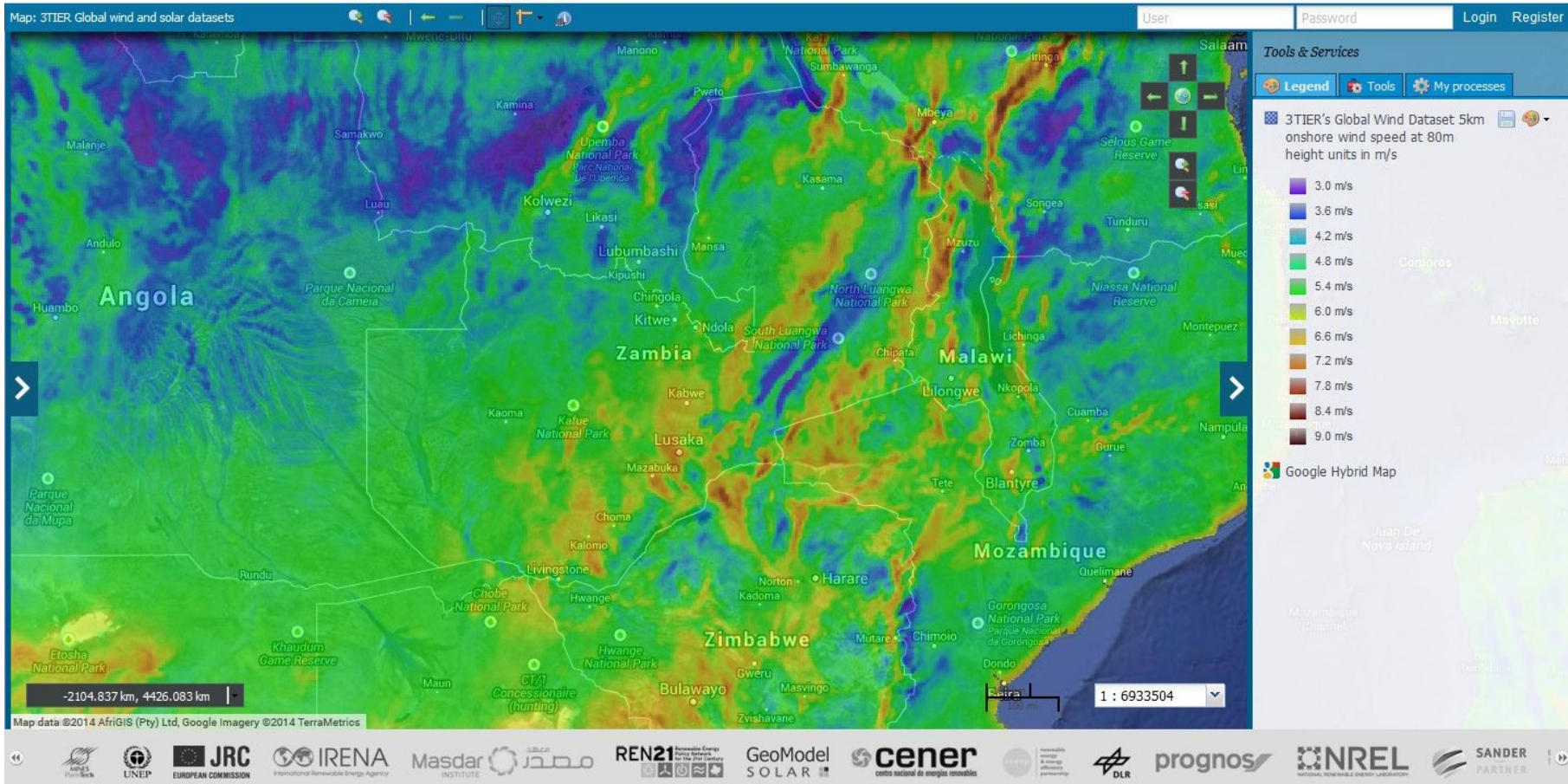

**Figure 4:** Global Atlas Showing Wind Speed Distribution in Zambia (IRENA, 2014)

**Table 2: Met Mast Summary for Eight Wind Resource Assessment Sites (DNV-GL, 2018).**

<b>Mast</b>	<b>Anemometer Heights</b>	<b>Anemometer manufacturer and model</b>	<b>Period</b>	<b>Calibration Certificate by MEASNET Facility</b>	<b>Anemometers mounted in Compliance with IEC Guideline</b>
<b>Choma</b>	80 m (x2), 60 m (x2), 42 m (x2), 20 m (x2)	Thies FCA, NRG Class 1	November 2016 – January 2018	Yes	Compliant
<b>Mwinilunga</b>	80 m (x2), 60 m (x2), 41 m (x2), 20 m (x2)	Thies FCA, NRG Class 1	December 2016 – January 2018	Yes	Compliant
<b>Lusaka</b>	80 m (x2), 60 m (x2), 41 m (x2), 20 m (x2)	Thies FCA, NRG Class 1	November 2016 – January 2018	Yes	Compliant
<b>Mpika</b>	80 m (x2), 60 m (x2), 41 m (x2), 20 m (x2)	Thies FCA, NRG Class 1	November 2016 – January 2018	Yes	Compliant
<b>Chanka</b>	80 m (x2), 60 m (x2), 41 m (x2), 20 m (x2)	Thies FCA, NRG Class 1	November 2016 – January 2018	Yes	Compliant
<b>Petauke</b>	80 m (x2), 60 m (x2), 41 m (x2), 20 m (x2)	Thies FCA, NRG Class 1	December 2016 – January 2018	Yes	Compliant
<b>Mansa</b>	80 m (x2), 60 m (x2), 41 m (x2), 20 m (x2)	Thies FCA, NRG Class 1	November 2016 – January 2018	Yes	Compliant
<b>Malawi</b>	80 m (x2), 60 m (x2), 41 m (x2), 20 m (x2)	Thies FCA, NRG Class 1	December 2016 – January 2018	Yes	Compliant

The exercise considered a theoretical 4 MW turbine with hub-height 130 m, therefore, the wind data was extrapolated to 130 m and the long term adjustments were applied. Table 3 shows the annual average wind speeds for the eight sites.

**Table 3:** Summary of Annual Average Wind Speeds at 80m and 130m (*DNV-GL, 2018*).

Site	Measured Wind Speed at 80 m	Long Term Adjusted Wind Speed at 80 m	Extrapolated Wind Speed at 130 m	Long Term Adjusted Wind Speed at 130 m
<b>Choma</b>	6.5 m/s	6.6 m/s	7.4 m/s	7.4 m/s
<b>Mwinilunga</b>	6.0 m/s	6.0 m/s	7.4 m/s	7.5 m/s
<b>Lusaka</b>	6.2 m/s	6.5 m/s	7.9 m/s	8.2 m/s
<b>Mpika</b>	6.2 m/s	6.3 m/s	7.3 m/s	7.3 m/s
<b>Chanka</b>	6.5 m/s	6.6 m/s	7.4 m/s	7.5 m/s
<b>Petauke</b>	5.7 m/s	5.7 m/s	6.5 m/s	7.0 m/s
<b>Mansa</b>	5.8 m/s	5.9 m/s	6.9 m/s	7.3 m/s
<b>Malawi</b>	5.8 m/s	5.8 m/s	6.9 m/s	7.1 m/s

From the annual average wind speeds shown in the table 3 it can be deduced that at 80 m height eight of the ten sites have Class IV wind speeds, two have wind speeds below Class IV and none has Class III wind speeds. However, at a much higher height of 130 m the scenario is different as four sites experience Class III wind speeds while the remaining six experience Class IV wind speeds.

This project is still on going with a final analysis to be conducted at 24 months of data collection, however the results of the final analysis are not expected to deviate significantly from the interim analysis. The findings of the interim analysis indicate that the potential for grid-scale wind power is available in Zambia.

The study being undertaken by DNV-GL is aimed at validating the Zambian wind map for wind power development. For a power project within 10 km of the masts the data can be used reliably to conduct a wind resource assessment for the wind farm. However, for sites outside the 10 km radius of the masts, the industry practice is to set up a mast within the project site and take measurements for six to twelve months.

There are two other feasibility studies which have been conducted in Zambia by different institutions. The final outputs from these studies are feasibility reports on development of wind power at the specific sites. The feasibility assessments in these

projects were detailed and took into consideration wind resource, environmental issues, constructability and grid connectivity (Wind Prospects, 2016; TDAU, 2016).

The aim of the study conducted by RINA on behalf of Kafue Gorge Regional Training Centre (KGRTC) aimed at installing a mast and conducting a feasibility of installing a single WT at a site within the Kafue Gorge. The proposed WT is of grid scale despite that its main purpose will be for training applications. The 60 m mast was installed in February 2017 and data collection commenced on 7<sup>th</sup> February 2017. Table 4 shows the summary of the KGRTC mast.

**Table 4:** Summary of the KGRTC mast.

<b>Mast Overview</b>			
Type		NRG 60 m Monopole	
Coordinates (UTM WGS84b35L)		X: 651,240 m Y:8,250,463 m	
Start Date		07 February 2017	
Effective data period		13.5 months	
<b>Instruments</b>			
Ch.	Type	Orientation [°N, mag.]	Height [m agl]
1	Thies CLIMA First Class	165	59.7
2	WindSensor P2546C	45	59.5
3	Thies CLIMA First Class	165	50.7
4	WindSensor P2546C	45	50.5
5	Thies CLIMA First Class	165	40.5
6	WindSensor P2546C	45	40.7
13	Renewable NRG Systems 200P	165	57.0
14	Renewable NRG Systems 200P	165	47.5
18	Renewable NRG Systems 110S	-	9.0
19	Renewable NRG Systems BP20	-	6.0

At the time of the Energy Yield Analysis (EYA), a total of 13.5 months of locally measured data was available for processing. The data was processed in accordance with the IEC guidelines and the results are shown in Table 5.

**Table 5:** Summary of Wind Data from KGRTC Mast (*RINA, 2018*).

Measured Wind Speed at 60 m	Long Term Adjusted Wind Speed at 60 m	Long Term Adjusted Wind Speed at 95 m
4.48 m/s	4.52 m/s	5.2 m/s

The annual average wind speed for this site at 95 m agl is below Class IV wind speeds and may not be viable for grid-scale wind power generation. However, it should be noted that if a higher height is considered, the site may experience Class IV winds.

A similar study was conducted by Technology Development and Advisory Unit (TDAU) for Rural Electrification Authority (REA). The aim of the study was to assess the wind resource potential at Kasomalunga in Lunga District for possible wind-solar hybrid power generation for an isolated min-grid for the island (TDAU, 2016). The overall purpose of the study was to assess the resource potential for small WTs for a 300 kW mini grid, however TDAU went a step further to include the analysis for grid-scale WTs. Just like the RINA study, a 60 m mast was installed with anemometers at 40 m, 50 m and 60 m. Two anemometers were installed at 60 m and 50 m, a barometer and temperature sensors were installed at 4 m. The mast was commissioned on 27<sup>th</sup> February 2017. Table 6 presents the summary of the Kasomalunga mast and Figure 5 shows the NRG 60 m mast installed at Kasomalunga in Luapula.

**Table 6:** Summary of Kasomalunga Mast.

<b>Mast Overview</b>			
Type		NRG 60m Monopole	
Coordinates		S 11°25'00.59" E 30°09'16.81"	
Start Date		01 March 2017	
Effective data period		12.7 months	
<b>Instruments</b>			
Ch.	Type	Orientation [°N, mag.]	Height [m agl]
1	Renewable NRG Systems 40C	0	60
2	Renewable NRG Systems 40C	90	60
3	Renewable NRG Systems 40C	0	50
4	Renewable NRG Systems 40C	90	50
5	Renewable NRG Systems 40C	0	40
6	Renewable NRG Systems 40C	90	40
13	Renewable NRG Systems 200P	0	57.5
14	Renewable NRG Systems 200P	90	47.5
19	Renewable NRG Systems 110S	-	4.0
16	Renewable NRG Systems BP20	-	4.0



**Figure 5:** The NRG 60 m Mast Installed at Kasomalunga in Luapula.

At the time of the EYA a total of 12.7 months locally measured data was available for processing. The study came up with two scenarios for the EYA. Scenario I included two smaller Vergnet GEV MP200 turbines which would be more practical for the mini-grid. Scenario II included two large Vestas V117 Turbines; this was done to indicate the potential for grid-scale wind power at the site and surrounding areas. The turbines for Scenario I had a hub height of 60 m whereas those for Scenario II had a hub height of 116.5 m. The data collected from the site was processed in accordance with the IEC guidelines and the results are shown in Table 7.

**Table 7:** Summary of Wind Data from Kasomalunga Mast (*TDAU, 2018*).

Measured Wind Speed at 60 m	Long Term Adjusted Wind Speed at 60 m	Long Term Adjusted Wind Speed at 116.5 m
5.52 m/s	5.4 m/s	6.8 m/s

The annual average wind speed at 60 m height for this site are less than Class IV hence not viable for grid-scale wind power generation, however the wind speeds may be adequate for an isolated system where energy storage is incorporated. When a higher height of 116.5 m was considered, the site was found to experience Class IV wind speeds with a possibility of attaining Class III wind speeds if the height is raised even higher.

The three studies that have been reviewed have indicated that there is wind resource potential for grid-scale wind power generation in certain parts of Zambia. It should be noted that these studies drew conclusions based on the wind resource, geographical and socio-environmental factors.

In as much as the findings from the above studies are critical, they only provide a starting point for wind power development. In order to operate in a sustainable manner, the wind power industry depends on support industries. These industries are from diverse sectors such as manufacturing, haulage and service. A strong local support industry is cardinal in establishing a sustainable environment for wind power development and growth. It further attracts the participation of big WT suppliers in the local and regional market. Suppliers tend to position themselves in specific market segments in order to preserve their competitive advantages and meet local requirements (The DTI, SA, 2012).

This research intends to bridge the gap that has not been addressed by the three studies mentioned above. The lack of information on the support industry may make it difficult for private sector participation in the wind power industry as the risks will be high.

## **2.4 Wind Turbine Components and Manufacture**

A WT has 8,000 parts in its assembly (GWEC, 2017), these are aggregated in sub-assemblies such as rotor, nacelle, tower, etc. The number of parts vary from one design to the other, so do the design features but they are all designed to do the same work of converting wind energy to electricity. This sub-section presents the major WT parts focusing on the design features and functionality, it further explores the various processes involved in their design and manufacture.

WTs are designed to convert the wind energy that exists at a location into electrical energy which is fed to an electricity grid. Therefore, aerodynamic modelling is employed at different stages of WT design as well as wind farm development. WTs are classified in two categories, viz, Vertical Axis Wind Turbines (VAWTs) and Horizontal Axis Wind Turbines (HAWTs).

The specific components of a WT vary from one manufacturer to another. However due to the fact that they are all designed for the same function, their generic components are the same. While there are numerous possibilities for WT system configurations, the majority of modern equipment consists of a horizontally configured drivetrain with two or three blades attached to an upstream facing rotor (Willey, 2010). The rotor is attached to the main shaft that drives a generator system for power conversion. The rotor is supported by at least one bearing located between the blades and the generator. The drivetrain and power conversion system are located in a nacelle mounted at the top of the tower. The nacelle is an enclosure that protects the power conversion equipment from the environment. A yaw system installed in the nacelle continuously changes the direction of the nacelle with changing wind direction to point and maintain the rotor facing upstream into the wind. Figure 6 shows the main components of a WT.

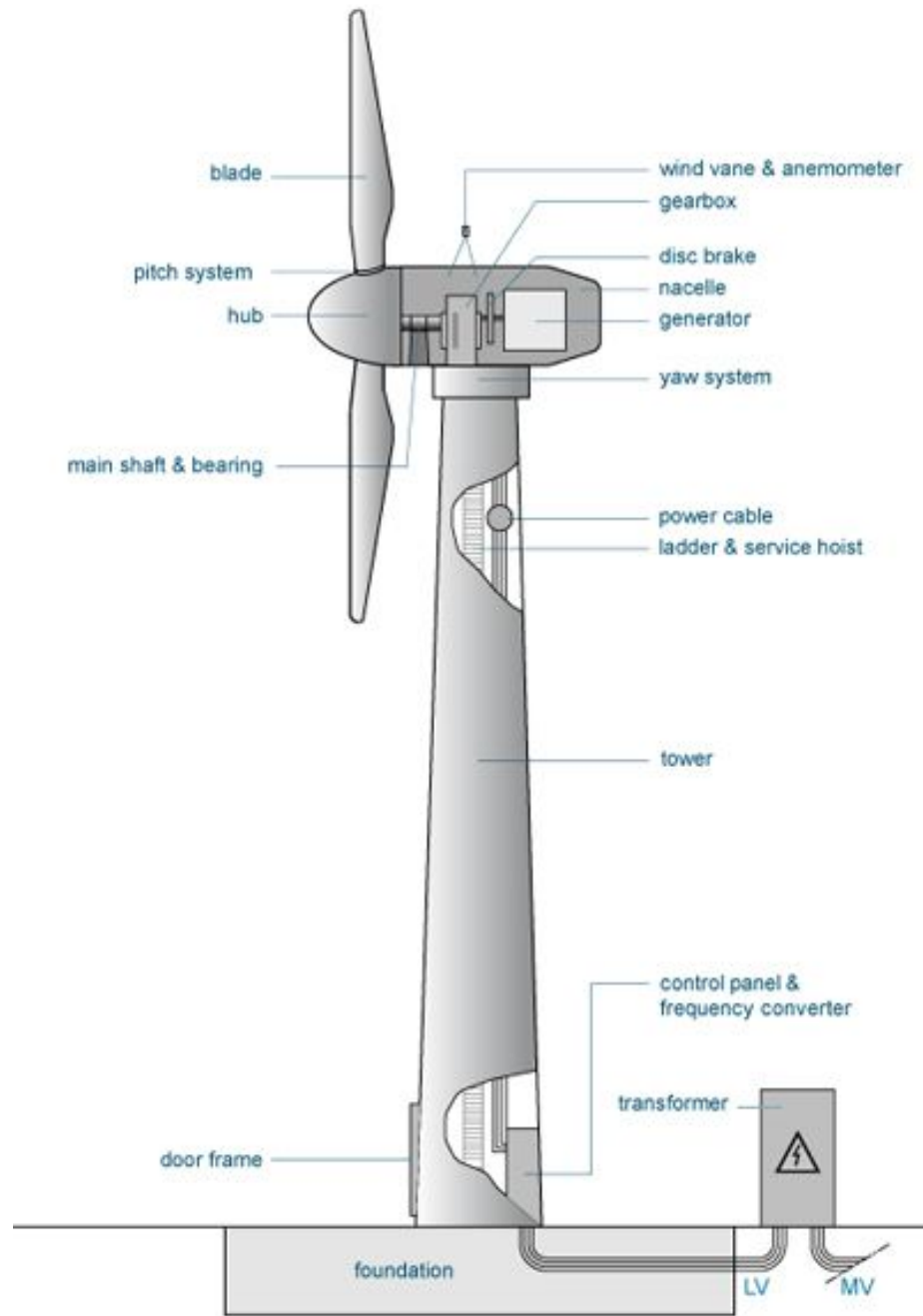

**Figure 6:** Components of a Wind Turbine (*Newen, n.d.*)

A turbine blade typically cost 10-15 % of system cost (Sandia National Laboratories, unkwon) whereas the tower has a cost of 20-25 % of the whole wind turbine system cost (Sungjin, et al., 2013). Therefore, the combined cost of these two components can be as high as 40 % of the system cost. This percentage may tend to get bigger for sites that are located further away from manufacturing facilities. This is due to the increased cost of transporting these components as they are the largest components and require

specialized transportation vehicles to haul them. The transport costs of importing blades and other equipment from countries such as China, can be as high as 5 % of the total amount (Maritz, 2011). Due to the above reason, this research focused on the blade and tower sections. It is envisaged that if these two components could be locally manufactured, the system cost of a wind farm could be reduced as well.

The following sub-sections present a detailed review of the blade and tower focusing on the design and subsequent manufacture of the components.

### 2.4.1 Blade

The blades are the most significant components of a WT as they are the primary mechanical parts which convert wind energy to rotational energy. There are two types of blades for wind turbines namely drag type and the lift type. The drag type relies on the wind's force to push the blades into motion. This was the case for old fashioned turbine blades and some micro/small turbine blades. Modern turbines use the lift type blades; these are based on more sophisticated aerodynamic principles to capture the wind's energy most effectively. These blades extract energy from the wind by utilizing the aerofoil design at the blade section a lot like airplane wings. In an aerofoil, one surface of the blade is somewhat rounded, while the other is relatively flat. Figure 7 shows the working principle of an aerofoil.

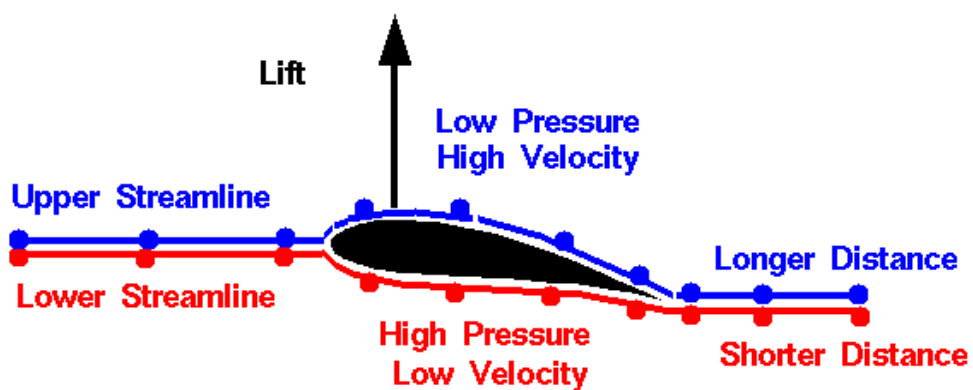

**Figure 7:** The Working Principle of an Aerofoil (NASA, n.d.)

When wind travels over the rounded, downwind face of the blade, it has to move faster to reach the end of the blade in time to meet the wind travelling over the flat, upwind face of the blade. This creates a velocity difference between the winds flowing on either sides of the aerofoil. According to Bernoulli's theorem, the faster moving air stream tends to lose pressure thereby creating a low pressure zone on the curved

surface. The low-pressure zone sucks the blade perpendicular to the downwind direction, an effect known as "lift." On the upwind side of the blade, the wind is moving slower and creating a higher pressure zone that pushes on the blade. This phenomenon brings into play the lift and drag forces, the lift force acts perpendicular to the direction of airflow while drag force acts in the direction of flow. Like in the design of an airplane wing, a high lift-to-drag ratio is essential in designing an efficient turbine blade. Since blade velocity increases with distance along the aerofoil, the angle of attack must also change along the aerofoil, therefore, turbine blades are twisted so that they can always present an angle that takes advantage of the ideal lift-to-drag force ratio.

The blades are given the highest consideration during the design stage as the efficiency of the WT largely depends on their performance. They undergo a rigorous design process whose aim is to increase the blade efficiency while reducing the cost of production. This approach results in a reduced Levelized Cost of Energy (LCoE).

There are several theories that have been developed for modelling a wind turbine blade's aerodynamic performance. The most commonly used is the Blade Element Momentum (BEM) theory. This is a combination of the classical blade element theory and the momentum theory. The BEM theory is based on the premise that the forces acting on the wind turbine blades are solely responsible for the change in axial momentum of the air passing through the swept area of the blades. BEM analysis is a combination of results from blade element theory and momentum theory. Blade element theory refers to the analysis of forces at a section of the blade, as a function of blade geometry. The blade is split into sections or strips along the length of the blade and each section is analysed separately. The results are combined at the end to provide a total power output for the turbine blade. This usually involves using either 2D CFD methods or experiments to produce look-up tables for aerofoil lift and drag data at different angles of attack (Mohan Das & Amano, 2014). It is beyond the scope of this study to present the details of the BEM theory, hence only a summary has been presented as indicated by the equations below.

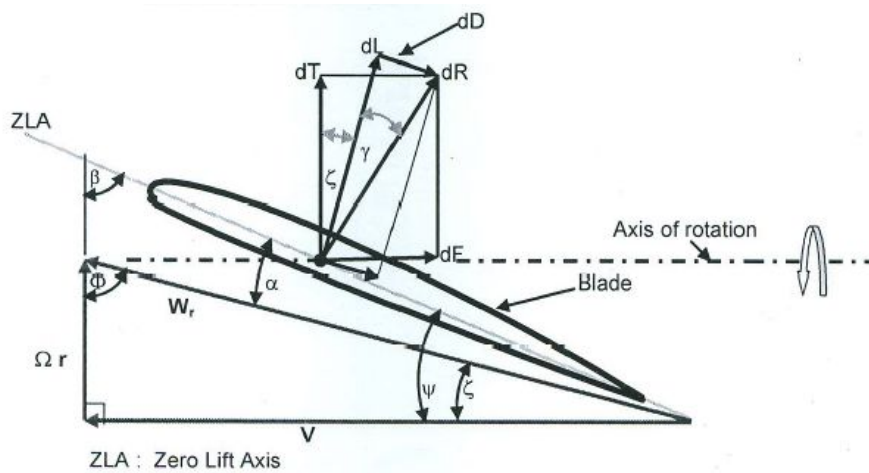

**Figure 8:** Force and Wind Vectors on a Blade Element According to the BEM

The BEM applies mathematical theorems to the force and wind vectors in Figure 8 in order to generate the two most important equations in WT design. These two equations are the torque equation and the thrust force equation.

The torque on the blade element is given by equation 1.

$$dQ = r \cdot dT \dots\dots\dots(1)$$

Where  $dQ$  = blade element torque

$r$  = blade radius from centre of axis of rotation

$dT$  = blade element tangential force component

Replacing  $dT$  with its components derived from Figure 8 gives Equation 2

$$dQ = \frac{\rho \cdot C_L \cdot b \cdot V^2 \cdot \cos(\xi + \gamma) \cdot r \cdot dr}{2 \cdot \cos^2 \xi \cdot \cos \gamma} \dots\dots\dots (2)$$

Where  $\rho$  = density of air

$C_L$  = Absolute lift coefficient for an aerofoil

$b$  = mean blade cord length

$V$  = air velocity

$\xi$  = angle between tangential and axial velocities

$\gamma$  = angle between lift and resultant force vectors

$dr$  = blade infinitesimal length

Integrating Equation 2 with respect to  $dr$  from  $R_0$  to  $R_1$  gives the total torque per blade

$$Q = \frac{\rho \cdot C_L \cdot b \cdot V^2 \cdot (R_1^2 - R_0^2) \cdot \cos(\xi + \gamma)}{4 \cdot \cos^2 \xi \cdot \cos \gamma} \dots\dots\dots (3)$$

Where  $R_1$  = blade tip radial distance

$R_0$  = blade root radial distance

The thrust force on the blade element is given by Equation 4 below

$$dF = dR \cdot \sin(\xi + \gamma) \dots\dots\dots (4)$$

Where  $dF$  = blade element axial force compent

$dR$  = blade element resultant force components

Inserting values of  $dR$  using vectors from Figure 8 gives Equation 5

$$dF = \frac{\rho \cdot C_L \cdot b \cdot V^2 \cdot \sin(\xi + \gamma) \cdot dr}{2 \cdot \cos^2 \xi \cdot \cos \gamma} \dots\dots\dots (5)$$

The total thrust per blade is obtained by integrating Equation 5, thus giving;

$$F = \frac{\rho \cdot C_L \cdot b \cdot V^2 \cdot (R_1 - R_0) \cdot \sin(\xi + \gamma)}{2 \cdot \cos^2 \xi \cdot \cos \gamma} \dots\dots\dots (6)$$

When designing WT blades, designers follow the guidelines provided in the IEC61400. This is a set of design requirements made to ensure that wind turbines are appropriately engineered against damage from hazards within the planned lifetime. These standards highlight most aspects of the turbine life from resource assessment to turbine components being designed, tested, assembled and operated.

The rotor diameter of a large scale WT range from 50 m upwards (Mwenda, 2017). The swept diameter for a Vestas V150-4.2 MW turbine is 150 m, a single blade is 73.7 m long and weighs 70 metric tons (Vestas, 2018). The cross section of the blade has an aerofoil design right from the root to the tip and just like in aircraft wings, a WT blade has different National Advisory Committee for Aeronautics (NACA) profiles at different segments of the blade. NACA profiles are aerofoil shapes for aircraft wings developed by the NACA.

Various studies have indicated different strategies for WT blade material selection, *Bassyouni and Gutub* found that a rational method to select the blade component material should depend on defining the function, objectives and design constraints

(Bassyouni & Gutub, 2013). Older WT's were small however as the wind power generation technologies matured, the size of WT's began to increase and so did the blades. These big scales of WT blades need lighter materials in order to optimize the generation of electricity (AlBat'hi, et al., 2015). Studies have been and are still being conducted in this field. These studies have led to the extensive use of Glass-Fiber Reinforced Polymer (GFRP) in modern blades. This is mainly due to the low weight of GFRP while maintaining the required structural rigidity. GFRP is easier to form into the desired aerofoil profiles used at different sections of the blade and can be manufactured as one component. This study focused on the GFRP WT blades because the manufacturing technologies involved are mature and are already being used in mass production.

A WT blade consists of two faces (on the suction side and the pressure side) joined together and stiffened either by one or several integral (shear) webs linking the upper and lower parts of the blade shell or by a box beam (box spar with shell fairings) (Mishnaevsky Jr, et al., 2017). Refer to Figure 9 for the schematic representation of the section of a typical blade.

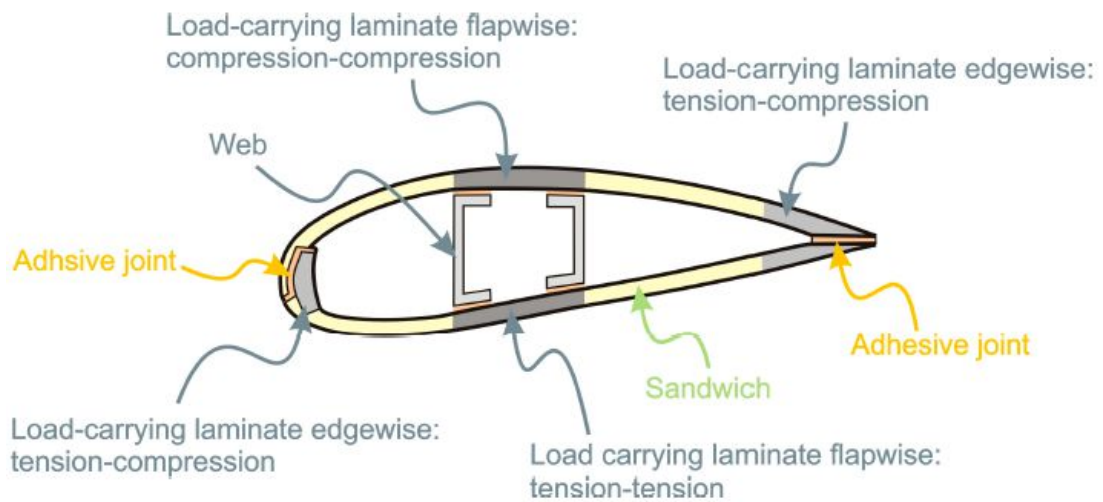

**Figure 9:** Schematic of a Typical Blade Section (Mishnaevsky Jr, et al., 2017)

There are two types of loads which are predominant on a WT blade namely the flap wise and edgewise loads. The flap wise load is caused by the wind pressure while the edgewise load is caused by gravitational forces and torque load. The flap wise loads tend to flap the blade hence internal webs or spar are incorporated inside the blade to resist the bending effect. The edges of the profile carry the edgewise bending caused

by gravitational and torque loads. From the point of loads on the blade, the laminate in the main spar on the pressure side is subjected to cyclic tension-tension loads while the other laminate on the suction side is subjected to cyclic compression-compression loads. The laminates at the leading and trailing edges that carry the bending moments associated with the gravitation loads are subjected to tension-compression loads. The aero shells, which are made of sandwich structures, are primarily designed against elastic buckling (Mishnaevsky Jr, et al., 2017).

The manufacturing process for GFRP WT blades is the same as any GFRP product except for the scale involved in WT blades. The first stage of the manufacturing process is to design and fabricate moulds for the different blade components. The number of moulds required to make a single blade depends on the blade design. For a blade design in Figure 8, up to four moulds are required, and other designs may require less moulds. The bottom shell and the top shell are made from two distinct moulds. These moulds are usually linked using a hydraulic system which enables the top mould to close on the bottom one during final assembly of the blade. Figure 10 shows hydraulically operated bottom and top moulds for a WT blade.



**Figure 10:** Moulds for Manufacturing WT Blades (*Vries, 2011*)

The moulds are sprayed with a gel coat for easy demoulding and improved surface finish of the blade. Gel coats are normally based on the same system as the resin (Det Norske Veritas, 2010). Pre-cut Glass-Fibre sheets are laid in the moulds making sure

that the sheets are flat, the number of sheets for each shell depends on the design of the blade and the properties of the Glass-Fibre sheet. When the required quantities of Glass-Fibre sheets have been laid in the mould, an air-tight plastic cover is placed on the mould and air is sucked out to create a vacuum. The resin is infused into the mould, the vacuum helps to spread the resin quickly and evenly. The resin merges with the Glass-Fibre in a process called curing. The period for the curing process varies from one manufacturer to another. After the curing process, the merged constituents form a single piece of a GFRP blade part. The webs are removed from the moulds and glued to the bottom part of the blade which is still in the mould. Further, glue is applied to the top surfaces of the bottom half and webs in preparation for the final assembly.

The final assembly is done by placing the top half mould over the bottom half mould. The glue is allowed to cure and bond the two halves together. The blade is removed from the mould using an overhead crane and placed in the machining section. A horizontal boring machine is used to drill anchoring holes at the root of the blade. The blade is delivered to the painting section, where the blade is sanded to remove any imperfections and greases which might interfere with the painting process. Paint is applied to the blade either manually or automated using robots. Typically, polyurethane and epoxy paints are used (Det Norske Veritas, 2010). Figure 11 shows automated painting of blades.



**Figure 11:** Painting Robots for WT blades (*Sainz, 2015*)

When the painting process is completed and the paint has fully dried, the blades are weighed and the weights recorded. The blades are placed in groups of three according to similar weight, this is to enable gyroscopic balancing of the rotor during operation. The grouped blades are placed in the collection yard waiting for shipping to site. Figure 12 shows a finished LM blade ready for shipping.



**Figure 12:** A Finished LM Blade Ready for Shipping (*LM Wind Power, n.d.*)

#### 2.4.2 Tower

The tower is the main structural support component of a WT. For utility scale WTs, the tower hub heights are in excess of 90 m above ground level (*agl*). The main function of the tower is to adequately raise the nacelle above the ground in order to access the higher wind speeds at higher heights. As a thumb rule it can be said that the tower height is almost the same as the rotor diameter (Eanest & Wizelius, 2011). A WT with rotor diameter of 120 m will have a tower with hub height approximately 120 m *agl*.

There are several different types of towers used in the wind power industry, however this study will discuss the four types namely Steel Tubular Conical, Lattice, Concrete and Hybrid towers. The selection of a tower for a site depends on environmental conditions, strength and economics.

##### a) Steel Tubular Conical Tower

Steel Tubular Conical towers are the most widely used by many wind power developers mainly because they provide better protection from the elements and have the best aesthetic appeal. These towers are conical (wider at the bottom and narrower at the top) and tubular (they are hollow in the middle) hence the name. These towers are made of shorter sections bolted together on site. The number of

sections in a tower differs from one manufacturer to another depending on the design, material and height of the tower. A Steel Tubular Conical Tower can have a cylindrical surface or a ribbed surface, the bottom part can be as wide as six meters while the top section can be four meters wide.

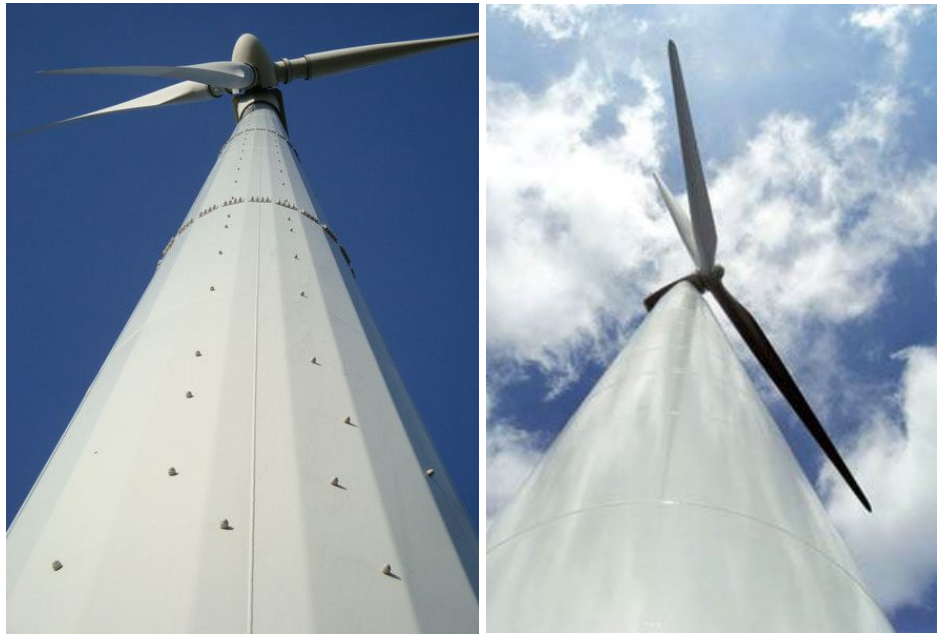

**Figure 13:** Ribbed and Cylindrical Steel Tubular Conical Towers

The Steel Tubular Conical Towers are manufactured from steel plates of varying thickness depending on the sections. The bottom sections are made from plates with thickness of about 25-27 mm while the top sections are made from plates with thickness of 16-20 mm. The manufacturing processes of the cylindrical and ribbed tubular tower are very similar to each other. The first step for both is to cut the steel plates to desired shapes.

In order to produce the cylindrical surface, the pre-cut plate is rolled into a conical sub-section. These sub-sections are welded together to form a tower section. Two flanges are then welded at both ends of the tower section. These will be used to assemble the tower sections on site. This process is the same for all the different sections of the tower.

When manufacturing the ribbed tower, the pre-cut plates are bent at several points to make half of a conical sub-section. These two halves are bolted together to form a full sub-section which is assembled to form a complete section. The complete sections are later bolted together on site during tower assembly. For this type of

tower, it is possible to assemble the half sub-sections on site during tower assembly. This can result in reduced transportation cost since the half sub-sections can be transported using conventional transportation vehicles.

In order to obtain a smooth finish, the tower sections or sub-sections are sand blasted to remove any imperfections and greases which might interfere with the painting process. Paint is applied to the sections either manually or automated using robots. Polyurethane and epoxy paints are used and the colour is matched to that of the blades. When the paint has sufficiently dried, the tower sections are moved to the dispatch area awaiting shipment.

**b) Lattice Tower**

A Lattice Tower is constructed using angle bars assembled in a criss-crossing manner forming a lattice, hence the name. All joints in a Lattice Tower are bolted together. Lattice Towers for the same stiffness of tubular tower, require only about half of the material and hence cheaper (Eanest & Wizelius, 2011). A Lattice Tower is supported by a four-corer foundation, where each corner post is bolted to a separate foundation. This type of foundation allows the tower legs to be spread over a wider footprint than that of tubular towers. It further requires less excavation and concrete for the foundation which in turn results in reduced foundation cost. Figure 14 shows the Fuhrländer Wind Turbine with a 160 m hub height lattice tower.

Additional advantages of Lattice Towers include higher self-damping properties due to several joints of the angle bars. Lattice Towers are easier to transport to site as they are knocked down allowing to be transported using conventional vehicles. The tower does not require a large staging yard during installation on site. Despite having several advantages lattice towers do have disadvantages such as not having a better aesthetic appeal compared to tubular towers. Lattice Towers do not provide any protection from the elements of weather. Lattice Towers are labour intensive as they require assembly of every single angle bar by hand.



**Figure 14:** The Fuhrländer Wind Turbine with a 160 m Hub Height Lattice Tower.  
(Esser-Systems, 2018)

The manufacturing of lattice towers follows a process very identical to that of other lattice towers such as pylons used for electricity transmission. The very first stage is receipt of the un-galvanised angle bars, these are inspected for straightness and those which do not meet the straightness requirements are taken for straightening. The straightening is done using an angle bar straightening machine. The straight angle bars are cut to required sizes using a hydraulic cutting machine which may be Computer Numeric Control (CNC) for improved productivity.

Holes are drilled or punched in the angle bars, where available this process is done by the same machine which cuts the angles to required sizes. The angle sections are finished off by cutting chamfers at the ends where interference is anticipated.

A mock assembly is conducted at the factory and the tower is inspected for any misfits which might render site assembly difficult or impossible. If the tower is passed, it is knocked down and the individual sections are sent to the galvanising plants. At the galvanising plant, the angle sections are galvanised and then transported to site for final assembly.

### **c) Concrete Tower**

Concrete Towers are made of concrete reinforced with steel for improved strength. These towers are tubular and conical just like their steel counterparts, however, they have better dampening characteristics. Concrete Towers are heavier than all the other types though cheaper. The major disadvantage of early concrete towers was that they could not be re-used, some modern concrete towers can be dismantled and re-used. Figure 15 shows a WT with a concrete tower.

There are two ways of constructing concrete towers namely in-situ and pre-cast constructions. In-situ construction as the name suggests is where the tower is constructed in-situ at the site. This type of construction does not require transportation or fitting the tower sections.

Pre-cast construction is the type of construction where the tower sections are pre-cast either at the factory or on site. The tower sections are assembled on site just like the tubular steel towers. This type of concrete tower is held together using steel cables which pass through dedicated holes in the concrete sections. The manufacture of pre-cast towers is the same as that of any pre-cast concrete. The process starts with preparation of the moulds followed by fixing of the steel cages

in the moulds. Then concrete is poured into the moulds and allowed to cure for some days. When the concrete has sufficiently cured, the moulds are removed. The pre-casts are cleaned and smoothed in readiness for painting. The pre-casts are then painted in the same colour as the blades and transported to site when the paint has sufficiently dried.



**Figure 15:** A Wind Turbine with a Concrete Tower.

#### d) Hybrid Tower

Hybrid Towers are made of at least two of the above tower types usually concrete and steel tubular sections. This is done in order to utilise the advantages from the two types of towers. The cheaper concrete sections are used at the bottom sections where it would be expensive to use the steel sections. Then the top part utilises the lighter steel sections for easy of lifting and fitting. The manufacturing process for the different sections is the same as that of the concrete or steel tubular sections. Figure 16 presents two variations of hybrid towers.



**Figure 16:** WTs with Hybrid Concrete-Steel Tower and Lattice-Steel Tower.

The tower is the main structural component of a WT and supports the rotor and nacelle above the ground. The tower is constantly subjected to various loads during the operation of the WT therefore the tower must be designed to withstand these loads. The design of WT is done in accordance with two international standards namely ISO 2394 which relates to reliability of structures and IEC 61400-1 which relates to design requirements of wind turbines. The IEC61400-1 identifies several loads which need to be considered during wind turbine design. These loads can be classified into static, quasi-static cyclic loads, dynamic cyclic loads or stochastic loads. It is the cyclic and

stochastic (turbulence-derived) loads that cause most structural failures, especially those due to fatigue (Eanest & Wizelius, 2011).

The Natural/Eigen frequency of a tower is the frequency at which the tower will start vibrating with a constantly increasing amplitude when excited with a constant force. This must be avoided as it can lead to destruction of the WT. The natural frequency of the tower is an important aspect of the WT tower, it can be used to classify a tower as stiff or soft. A soft tower is one having a natural frequency greater than the blade passing frequency where as a soft tower is one having a natural frequency in between the blade passing frequency and the rotational frequency. However, a soft-soft tower is one with a natural frequency lower than both the blade passing frequency and the rotational frequency. The Eigen frequency depends on the tower height, wall thickness, type of material and weight of nacelle and rotor. For a WT the Eigen frequency of the tower can be found using equation (7);

$$f_n = \frac{1}{2\pi} \sqrt{\frac{3.E.I}{(0.23m_{tower}+m_{WT})L^3}} \dots\dots\dots(7)$$

Where

$f_n$ = fundamental natural frequency

E= the modulus of elasticity

I – the moment of inertia of the tower cross-section

$m_{tower}$ = the mass of the tower

$m_{WT}$ = the mass of the WT

L = height of the tower

For towers which will have to operate at sites where the natural frequencies could be between 40 % and 130 %, the dynamic factor D is used to multiply design loads in evaluating the tower. The dynamic factor D is given by equation (8);

$$D = \frac{1}{\sqrt{\frac{1}{[1-(f_e/f_n)^2]^2 + [2\epsilon(f_e/f_n)]^2}}} \dots\dots\dots(8)$$

Where

$F_n$  = fundamental natural frequency (Hz)

$F_e$  = excitation frequency (Hz)

$\varepsilon$  = damping ration given by  $\varepsilon = \delta/2\pi$

$\delta$ = the logarithmic damping decrement (which is between 0.05 for steel and 0.1 for reinforced concrete)

The purpose of tower design is to avoid resonant tower oscillations where its natural frequency coincide with the turbine's excitation frequencies. On the basis of the wind fluctuation frequency, measurements at a particular site, the resonance frequency of the tower is determined by complete modal analysis using Eigen vectors and Eigen values (Eanest & Wizelius, 2011).

## **2.5 Installation of Wind Turbines**

WTs are usually installed by the manufacturer while the developer may provide lifting equipment such as cranes. Prior to installation the developer will be required to prepare the site by casting foundations, making access roads and a crane hardstand. The installation of a wind farm takes no more than six months (Wind Prospect, n.d.). There are several processes and equipment that are involved in the installation of a WT however this literature review briefly discussed the processes that involve transportation and installation of blades and towers.

Transportation of WT blades and tower sections is done using specialised vehicles which are usually very long. The critical components are the blades and tower sections which are usually ferried using specifically designed or modified carriers. The blades are moulded in full length except for larger WTs such as the Vestas V164 which has the blades moulded in sections to ease the transportation process. During feasibility study of a wind power project, a detailed route analysis is usually conducted. Some sections of the road may be widened, trees may be cut down and telephone/power lines may be temporary removed. The transportation vehicles for WT blades and tower sections vary extremely, Figures 17 and 18 show the variety of blade and tower section transportation vehicles.



**Figure 17:** Transportation of an 83.5 m long WT Blade from Danish SSP Technology (*SSP-Technology, 2017*)



**Figure 18:** Transportation of a WT Tower Section by Ace Doran Haulage and Rigging (*Ace-Doran, 2017*)

Installation of a WT involves hoisting of heavy tower sections, blades and nacelle to heights in excess of 130 m above ground level. This requires the use of high capacity and high reach cranes. A 2 MW WT requires a crane with capacity to lift 600 tons for hoisting tower sections, nacelle and rotor into position (Enerst, 2014). The cranes are usually hired from the local haulage company. When all the WT components are onsite and the weather is fair, a WT can be installed in a single day. Figure 19 shows the installation process of a WT.



**Figure 19:** Wind Turbine Installation (*SSP-Technology, 2017*)

## **CHAPTER THREE: METHODOLOGY OF THE STUDY**

This chapter presents the methodology which was employed in this study. It discusses in detail the research design, study population and study sample, sampling technique, data collection tools and data analysis.

### **3.1 Research Design**

There are two basic approaches to research namely qualitative approach and quantitative approach (Kothari, 2004). The qualitative approach is concerned with subjective assessment of attitudes, opinions and behaviour whereas the quantitative approach involves the generation of data in quantitative form which can be subjected to rigorous quantitative analysis in a formal and rigid fashion.

This study used a mixed-method approach which utilized the two basic approaches in a complementary manner so as to simultaneously garner the benefits of both approaches. The mixed-method approach allowed the initial assessment of the research topic during desk study in order to gain insight of the research situation and was further used to develop a measuring tool and consequent comprehensive analysis of the research situation. The mixed-method approach which was adopted in this study executed the qualitative and quantitative approaches in a respective sequential manner. This approach explored the research situation using qualitative data then measured and analysed it quantitatively.

In the first phase of the study, qualitative data was collected from Zambia Association of Manufacturers (ZAM). The collection of the qualitative data was done by formally requesting for brief profiles of manufacturers conducting business in three categories namely GFRP Manufacturing, Mechanical Engineering and Pre-Cast Concrete Manufacturing. This data was arranged in three strata according to the categories above. The data was filtered so as to achieve a homogeneous characteristic throughout the population in each stratum. The qualitative data was used to define the study population and develop a quantitative data collection tool.

### **3.2 Study Population and Study Sample**

This study classified the study population into three strata, the characteristics of the population in each stratum was homogenous. The three strata were named as GFRP

Manufacturers, Mechanical Engineering Plants/Workshops and Pre-Cast Concrete Manufacturers. These strata are discussed in detail in the following paragraphs.

The stratum for GFRP Manufacturers composed of all companies which manufacture GFRP products. The stratum further included other polymer manufacturers whose processes involve the use of moulds; this inclusion was done based on the assumption that these processes are very similar to GFRP processes thus such companies switch to GFRP processing. This stratum was defined as a group of individual companies capable of producing GFRP products.

The stratum for Mechanical Engineering Plants/Workshops included all companies which are involved in heavy mechanical engineering works involving roll-bending and machining processes. This stratum was defined as a group of individual companies capable of machining and bending plates into finished products.

The Pre-Cast Concrete Manufacturers stratum was composed of companies involved in the production of pre-cast concrete sections for various applications. Therefore, the stratum was defined as a group of individual companies capable of producing pre-cast concrete sections.

The population in each stratum was defined by a qualitative parameter, hence it was not possible to establish the standard deviation. The above statement further hints a possibility of significant variability among individual members of the stratum. The study took the above concerns into consideration and collected data from the whole population in each of the three strata, hence the sample size was the whole population. Conducting the study on the whole population meant that the sample was a true representative of the population. This approach eliminated the sampling error which could have been incurred in the study. Due to the small size of the population, it was possible to conduct the study on whole population within the research budget.

### **3.3 Data Collection**

The study used a mixed-method approach, therefore, data was collected using both qualitative and quantitative methods. The qualitative data was collected by formally requesting for brief profiles of manufacturers conducting business in three categories namely GFRP Manufacturing, Mechanical Engineering and Pre-Cast Concrete Manufacturing.

A quantitative data collection tool was developed using findings from the qualitative study and literature review. The data collection tool which was developed were questionnaires, this was due to the low cost of data collection using this tool and the fact that the study covered the whole population meant that the results would be reliable. According to *Kothari*, it is always advisable to conduct a ‘pilot study’ (Pilot Survey) for testing the questionnaires (Kothari, 2004). Therefore, the questionnaires which were developed were tested and the findings were used to refine them. Refer to Appendices A and B for the questionnaires developed for each stratum.

The questionnaires were hand delivered to all the individual companies involved in the study. Some questionnaires were filled in right away others had to be collected after a few days. The filled questionnaires were grouped according to the strata in readiness for analysis.

### **3.4 Data Analysis**

The quantitative data which was collected using questionnaires was collated and analysed using MS Excel 2016. MS Excel was selected based on availability and ease to use. Further, MS Excel was capable of producing the required results within an acceptable degree of accuracy. The MS Excel 2016 was used to generate various statistics which informed the discussion, conclusion and recommendations.

## CHAPTER FOUR: RESULTS/FINDINGS

This chapter presents the results which were obtained from a review of the wind resource assessment projects being undertaken in Zambia. The study further presents the results obtained from the analysis of data collected from various respondents. These results are presented according to three categories namely WT Blade manufacturing, Steel Tower Manufacturing, Pre-Fabricated Concrete Tower Manufacturing and Constraints. The results are presented in the following sections;

### 4.1 Review of Grid-Scale Wind Power Potential

#### 4.1.1 Grid-Scale Wind Resource Potential in Zambia

Table 8 shows the summary of the annual average wind speed for the ten sites covered by wind resource assessment projects undertaken in Zambia.

**Table 8:** Summary of Annual Average Wind Speeds at Ten Sites in Zambia.

Site	Measurement Height [m]	Long Term Adjusted Wind Speed @ Measurement Height [m/s]	Extrapolated Height [m]	Long Term Adjusted Wind Speed @ Extrapolated Height [m/s]
Choma	80	6.6	130	7.4
Mwinilunga	80	6.0	130	7.5
Lusaka	80	6.5	130	8.2
Mpika	80	6.3	130	7.3
Chanka	80	6.6	130	7.5
Petauke	80	5.7	130	7.0
Mansa	80	5.9	130	7.3
Malawi	80	5.8	130	7.1
Kasomalunga	60	5.4	116.5	6.8
KGRTC	60	4.52	95	5.2

From the annual average wind speeds shown in the Table 8 it can be deduced that at least four out of ten sites have Class III wind speeds while five have Class IV and one is below Class IV. It should be noted that if Kasomalunga and KGRTC were extrapolated to 130 m height, it would be possible to have a total of five sites with Class III wind speeds and five with Class IV wind speeds.

#### 4.1.2 Reference WT for Zambia

A review of the feasibility study reports for various sites in Zambia has indicated that 40 % of the sites under investigation could sustain a Class III WT with a Hub height of 130 m. Further, it should be noted that it is possible that all the sites under investigation can sustain a Class IV WT with hub height of 130 m. This study focused on the Class III WTs due to the lower initial cost compared to Class IV WTs. Considering the above explanations, this study adopted a Class III WT with hub height of 130 m and mean rated capacity of 4 MW for the Zambian wind regime, the specifications are detailed in Table 9;

**Table 9:** Specifications for a Reference WT for Zambia.

Item	Specifications
<b>Rotor</b>	
Rated Power (MW)	3-4.5
Wind Class	IEC III
Cut-in Wind Speed (m/s)	2.5 – 3
Rated Wind Speed (m/s)	9 – 11
Design Survival Life (yrs)	≥20
Operating Temperature Range (°C)	-30 to +40
Survival Temperature Range (°C)	-40 to +50
Nominal Rated Diameter (m)	150 (depending on rated power)
Approximate blade length (m)	75
Approximate blade weight (ton)	70
<b>Electrical</b>	
Frequency (Hz)	50
Output Voltage (V)	Depends on grid connection point
<b>Brake System</b>	
Aerodynamic Brake System	Blade Pitch control
Mechanical Brake System	Hydraulic Mechanical Brake System
<b>Yaw System</b>	
Type	Motor Drive
Yaw Brake	Hydraulic Brake
<b>Lightening Protection</b>	
Type	IEC 61400 compliant
<b>Tower</b>	
Type	Steel Conical, Lattice, Concrete, Hybrid
Hub Height (m)	≥130

The specifications in the table were based on the GW 3S turbine supplied by Gold Wind and the Vestas 150 supplied by Vestas.

#### 4.1.3 Reference Manufacturing Facilities

This study focused on the largest and most expensive components of a WT which are the blades and tower. Therefore, only the manufacturing facilities related to WT blades and tower were considered in the study. The standard manufacturing facilities for blades and towers have been adopted and are presented in Tables 10 to 13.

**Table 10:** General Specifications for Reference WT Blade Manufacturing Facilities.

Infrastructure	Specification
Mould Section	<ul style="list-style-type: none"> <li>✓ Not less than 100 m x 20 m enclosed area</li> <li>✓ Polymer infusion equipment</li> <li>✓ 100 ton overhead crane or equivalent alternative</li> <li>✓ Raw materials storage</li> </ul>
Machining Section	<ul style="list-style-type: none"> <li>✓ Not less than 100 m x 20 m enclosed area</li> <li>✓ Horizontal boring machine or equivalent</li> <li>✓ 80 ton overhead crane or equivalent alternative</li> </ul>
Painting Section	<ul style="list-style-type: none"> <li>✓ Not less than 100 m x 50 m enclosed area</li> <li>✓ GFRP sanding equipment</li> <li>✓ Spray painting equipment</li> <li>✓ 80 ton overhead crane or equivalent alternative</li> </ul>
Dispatch	<ul style="list-style-type: none"> <li>✓ Not less than 100 m x 20 m open area</li> <li>✓ 80 ton tower crane or equivalent alternative</li> </ul>

**Table 11:** General Specifications for Reference WT Steel Tubular Manufacturing Facilities.

<b>Infrastructure</b>	<b>Specification</b>
Raw Material	<ul style="list-style-type: none"> <li>✓ Not less than 20 m x 20 m open area</li> <li>✓ 5 ton plate handling equipment</li> </ul>
Rolling & Joining Section	<ul style="list-style-type: none"> <li>✓ Not less than 50 m x 20 m enclosed area</li> <li>✓ Plate cutting equipment</li> <li>✓ Rolling equipment (up to 25 mm thick plates)</li> <li>✓ Welding equipment</li> <li>✓ 80 ton overhead crane or equivalent alternative</li> </ul>
Painting Section	<ul style="list-style-type: none"> <li>✓ Not less than 50 m x 20 m enclosed area</li> <li>✓ Steel sanding equipment</li> <li>✓ Spray painting equipment</li> <li>✓ 80 ton overhead crane or equivalent alternative</li> </ul>
Dispatch	<ul style="list-style-type: none"> <li>✓ Not less than 50 m x 50 m open area</li> <li>✓ 80 ton tower crane or equivalent alternative</li> </ul>

**Table 12:** General Specifications for Reference WT Lattice Tower Manufacturing Facilities.

<b>Infrastructure</b>	<b>Specification</b>
Raw Material	<ul style="list-style-type: none"> <li>✓ Not less than 20 m x 20 m open area</li> <li>✓ Angle bar handling equipment</li> </ul>
Cutting/Punching Section	<ul style="list-style-type: none"> <li>✓ Not less than 50 m x 20 m enclosed area</li> <li>✓ Angle bar straightening machine</li> <li>✓ Angle bar cutting/punching machine</li> <li>✓ Angle bar handling equipment</li> </ul>
Mock Assembly Yard	<ul style="list-style-type: none"> <li>✓ Not less than 150 m x 20 m open and flat area</li> </ul>
Galvanising Section	<ul style="list-style-type: none"> <li>✓ Not less than 50 m x 20 m enclosed</li> <li>✓ Galvanising plant</li> <li>✓ Angle bar handling equipment</li> </ul>
Dispatch	<ul style="list-style-type: none"> <li>✓ Not less than 50 m x 50 m open area</li> <li>✓ 5 ton forklift</li> </ul>

**Table 13:** General Specifications for Reference WT Concrete Tower Manufacturing Facilities.

Infrastructure	Specification
Mould Section	<ul style="list-style-type: none"> <li>✓ Not less than 50 m x 50 m open or enclosed mould area</li> <li>✓ 50 ton crane or equivalent alternative</li> <li>✓ Raw materials storage</li> </ul>
Painting Section	<ul style="list-style-type: none"> <li>✓ Not less than 50 m x 20 m enclosed area</li> <li>✓ Concrete cleaning equipment</li> <li>✓ Spray painting equipment</li> <li>✓ 50 ton crane or equivalent alternative</li> </ul>
Dispatch	<ul style="list-style-type: none"> <li>✓ Not less than 50 m x 20 m open area</li> <li>✓ 50 ton crane or equivalent alternative</li> </ul>

Tables 10 to 13 indicate that blade manufacturing facilities, steel tubular manufacturing facilities and concrete tower manufacturing facilities can each be accommodated in an area of about one hectare or more. However, steel lattice tower manufacturing requires an area equal to or greater than 1.5 hectare. It should be noted that these area requirements are based on a space optimisation approach as such these are just trigger points.

#### 4.2 WT Blade Manufacturing

Table 14 present the basic information of the survey in relation to the population size, sample and response rate.

**Table 14:** Basic Survey Information on WT Blade Manufacturing.

Population	10
Number of questionnaires	10
Number of Responses	6
Response Rate	60 %

The information from Table 14 indicates that the response rate was at 60 %. Figure 20 presents a chart showing the percentage of companies which can manufacture GFRP products.

### COMPANIES THAT MANUFACTURE GFRP PRODUCTS

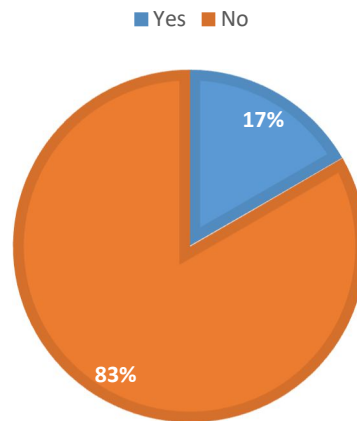
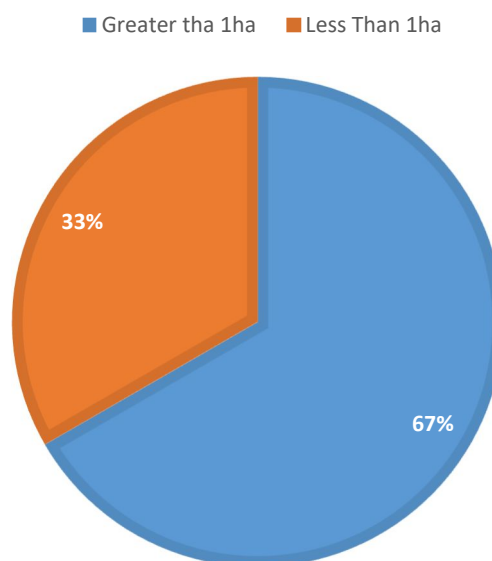

**Figure 20:** Percentage of Companies which can Manufacture GFRP Products

Figure 20 indicates that 17 % of the companies that responded to the questionnaire can manufacture GFRP products while 83 % cannot.

Figure 21 shows the percentage of companies that occupy an area greater than one hectare and those occupying an area less than one hectare. From the chart it can be deduced that 67 % of the companies that responded occupy an area which is greater than one hectare.

### TOTAL PREMISE AREA



**Figure 21:** Total Premise Area Occupied by Companies

Table 15 shows the type of infrastructure available on company premises of the respondents.

**Table 15:** Available Infrastructure on Polymer Company Premises.

Name	Specifications
Shade	50 m x 200 m
Shade	20 m x 100 m
Shade	40 m x 160 m
Shade	50 m x 80 m

In Figure 22, the chart shows that 33 % of companies have adequate sheltered space to accommodate a mould measuring up to 75 m long and up to 4.5 m wide.

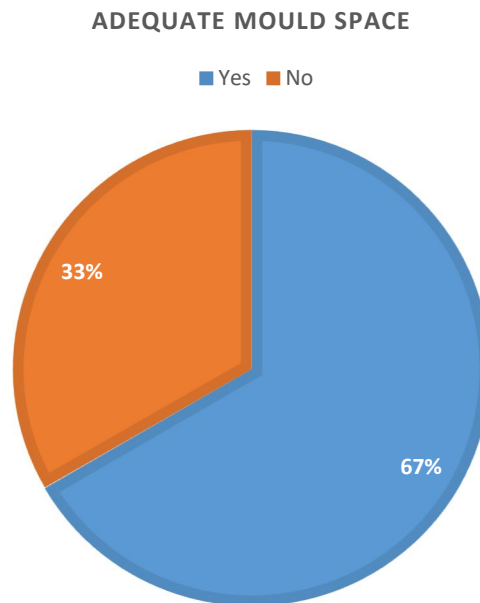

**Figure 22:** Companies with Adequate Mould Space

Figure 23 indicates that 17 % of the companies that responded can conduct surface finishing operations on GFRP products

### GFRP SURFACE FINISHING

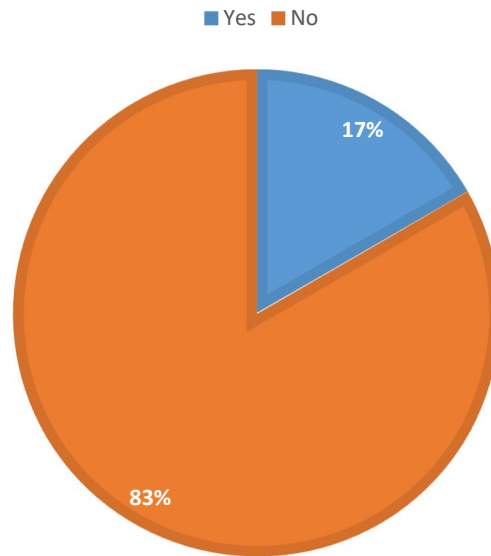

**Figure 23:** Companies which conduct GFRP surface finishing operations

Table 16 lists the tools currently being used for surface finish operations on GFRP products.

**Table 16:** Available GFRP Surface Finishing Tools and Skills.

Operation	Tools	Skills
Cleaning	Brooms and water	Job on training
Painting	Paint brushes	Job on training

#### 4.2.1 Steel Tower Manufacturing

Table 17 presents the basic information on steel tower manufacturing survey

**Table 17:** Basic Survey Information.

Population	10
Number of Questionnaires	10
Number of Responses	7
Response Rate	70 %

Figure 24 show the total area occupied by companies which participated in the study. The results show that 28 % occupy an area greater than or equal to 1.5 ha, 43 % occupy an area greater than 0.7 ha but less than 1.5 ha and 29 % occupy an area less than 0.7 ha.

### Total Premise Area

■ More than 1.5ha   ■ Between 1.5ha and 0.7ha   ■ Less than 0.7ha

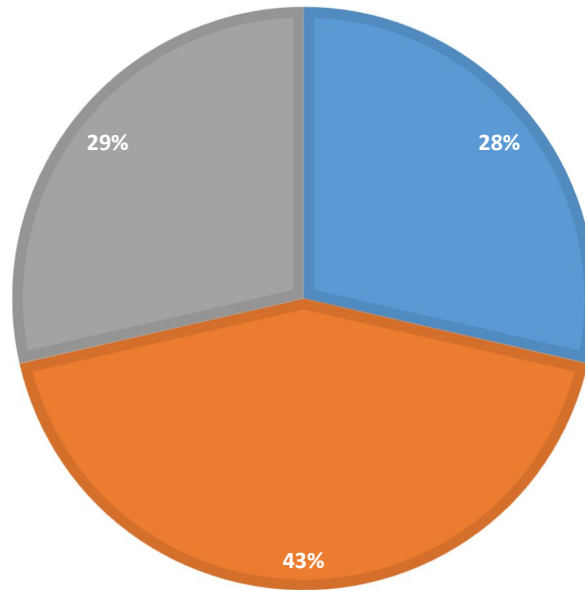

**Figure 24:** Total Area Occupied by Mechanical Engineering Plants/Workshops

Table 18 presents the infrastructure how at the Mechanical Engineering Plants/Workshops

**Table 18:** Available Infrastructure at Mechanical Engineering Plants/Workshops

Name	Specifications
Shade	15 m x 100 m
Shade	20 m x 30 m
Shade	15 m x 80 m

#### 4.2.2 Steel Tubular Tower Manufacturing

Figure 25 indicates that 57 % of the respondents can cut steel plates with thickness of 25 mm.

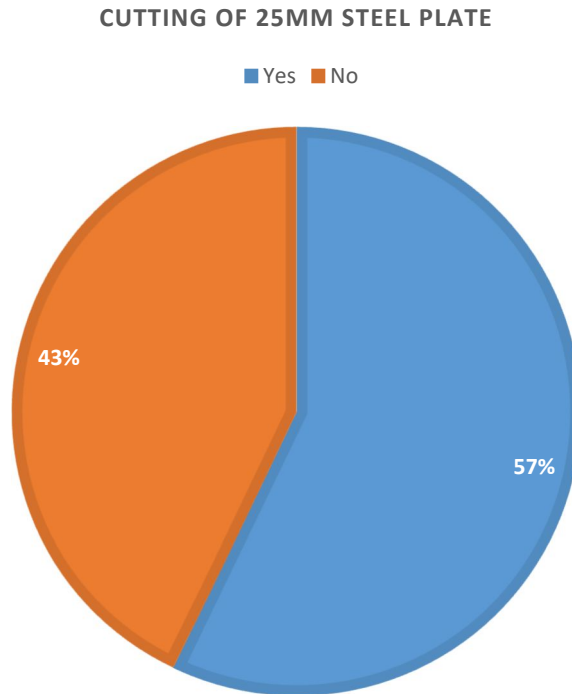

**Figure 25:** Mechanical Engineering Plants/Workshops Which Can Cut 25 mm steel Plates

Figure 26 shows that 29 % of the respondents can weld steel plates 25 mm thick while 71 % do not have equipment to do so. Further, Figure 27 indicates that 71 % of the respondents can conduct surface finish operations on steel surfaces. These operations include but not limited to surface cleaning and application of an epoxy/polyurethane paint.

WELDING OF 25MM STEEL PLATE

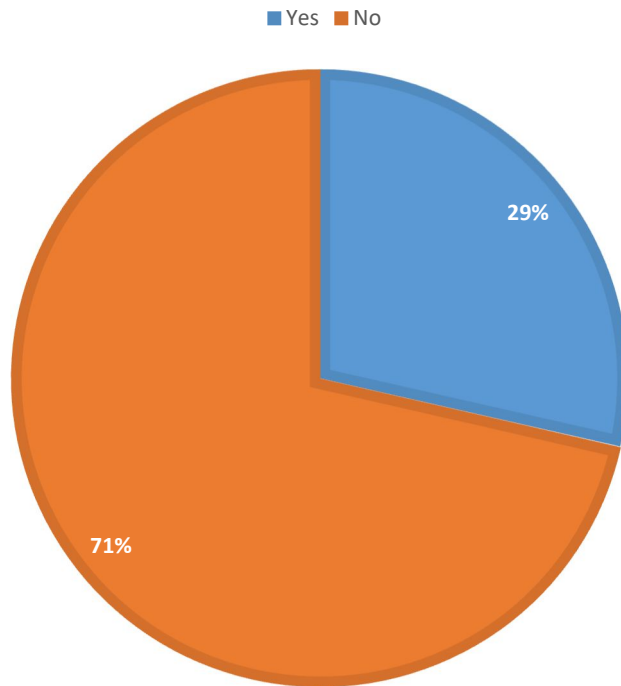

**Figure 26:** Mechanical Engineering Plants/Workshops Which Can Weld 25 mm Steel Plates

SURFACE FINISHING

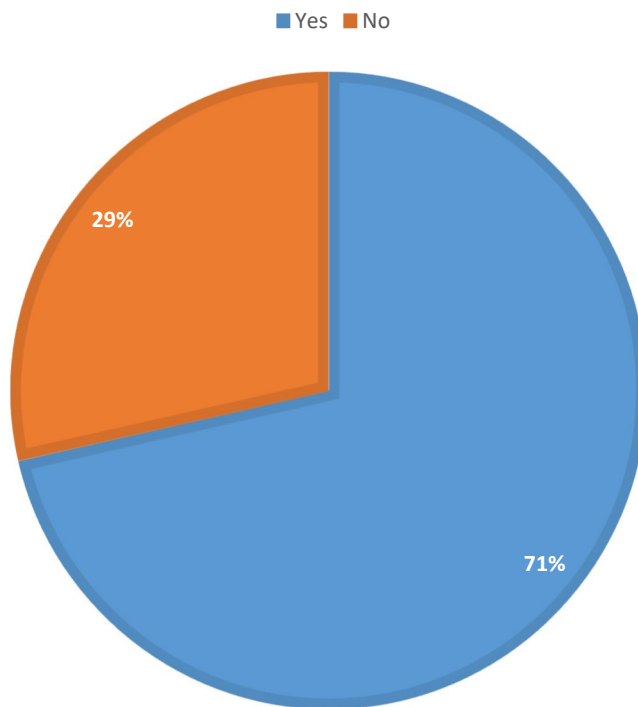

**Figure 27:** Mechanical Engineering Plants/Workshops Which Can Conduct Surface Finishing on Steel Surfaces

There are no companies which have equipment to conduct roll-bending or bending operations on steel plates with thickness of 25 mm, the biggest available roll/bending machine could bend steel plates up to 16 mm thick. Table 19 presents some of the available equipment which can be used to handle steel plates of 25 mm thickness.

**Table 19:** Available Equipment To Handle Steel Plates of 25 mm Thickness.

Operation	Tools	Skills
Lifting	Crane/forklift	Craft/Technician
Cutting	Plasma/gas cutting	Craft/Technician
Welding	Low hydrogen welding/MIG/TIG	Craft/Technician
Cleaning	Sand blasting	Craft/Technician
Painting	Spray painting	Craft/technician

### 4.2.3 Steel Lattice Tower Manufacturing

Figure 28 indicates that 14 % of the respondent have equipment to straighten angle bars measuring 150 mm by 150 mm before further processing while 86 % can not conduct the operation.

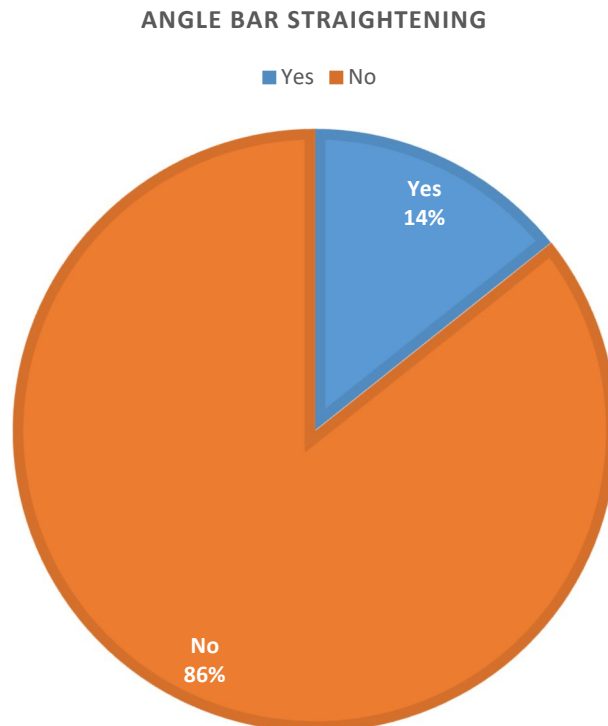

**Figure 28:** Mechanical Engineering Plants/Workshops Which Can Straighten 150 mm x150 mm Angle Bars

### ANGLE BAR CUTTING

■ Yes ■ No

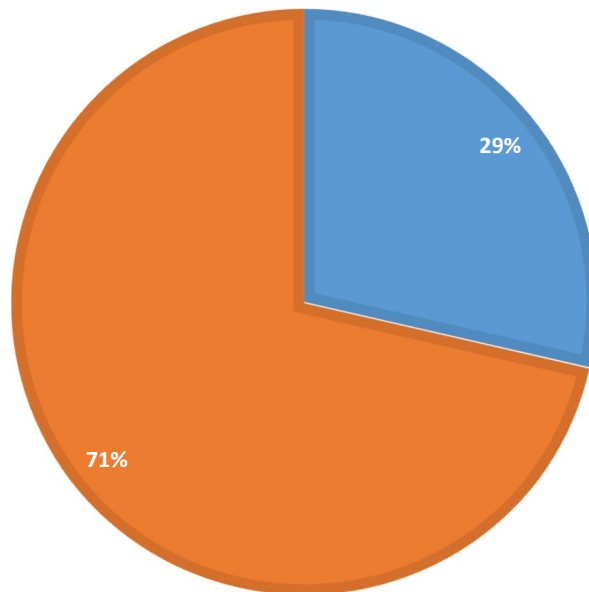

**Figure 29:** Mechanical Engineering Plants/Workshops Which Can Cut 150 mm x 150 mm Angle Bars

### ANGLE BAR PUNCHING

■ Yes ■ No

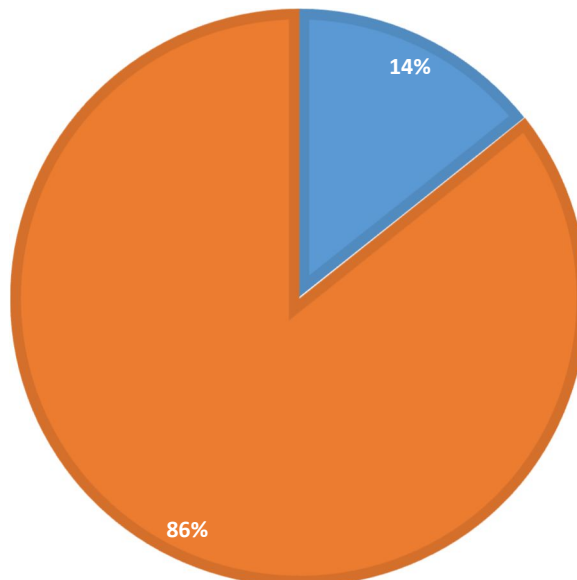

**Figure 30:** Mechanical Engineering Plants/Workshops Which Can Punch Holes Into 150 mm x 150 mm Angle Bars

Figure 29 shows that 29 % of the respondents can cut angle bars measuring 150 mm by 150 mm into required lengths. Further Figure 30 indicates that 14 % of the respondents are capable of punching holes into angle bars according to specifications. It should be noted that none of the respondents had a galvanising plant. Table 20 presents some of the available equipment which can be used to handle angle bars measuring 150 mm by 150 mm.

**Table 20:** Available Equipment to Handle Angle Bars Measuring 150 mm by 150mm.

Operation	Tools	Skills
Straightening	Press machine	Craft/Technician
Cutting	Profile cutter/power saw/guillotine	Craft/Technician
Punching	Press machine/Drilling machine	Craft/Technician

#### 4.2.4 Pre-Fabricated Concrete Sections

Table 21 presents the basic information on pre-fabricated concrete tower manufacturing survey.

**Table 21:** Basic Survey Information on Pre-Fabricated Concrete Towers.

Population	04
Number of Questionnaires	04
Number of Responses	0
Response Rate	0 %

There were no responses to the questionnaires administered to this group.

#### 4.3 Priority Gap Analysis

Table 22 presents the basic information on the gaps covered under this survey.

**Table 22:** Basic Survey Information Gap Analysis.

Population	20
Questionnaires	20
Reponses	13
Response Rate	65%

Several gaps which could hinder the participation of local companies in wind power development were investigated in this study. There are numerous gaps which can be investigated, however this study focused on five namely lack of government policies,

lack of capex for recapitalization, lack of sustainable market for WTs, limitation in production capacity and competing markets. The results from the survey are presented as histograms in Figure 31.

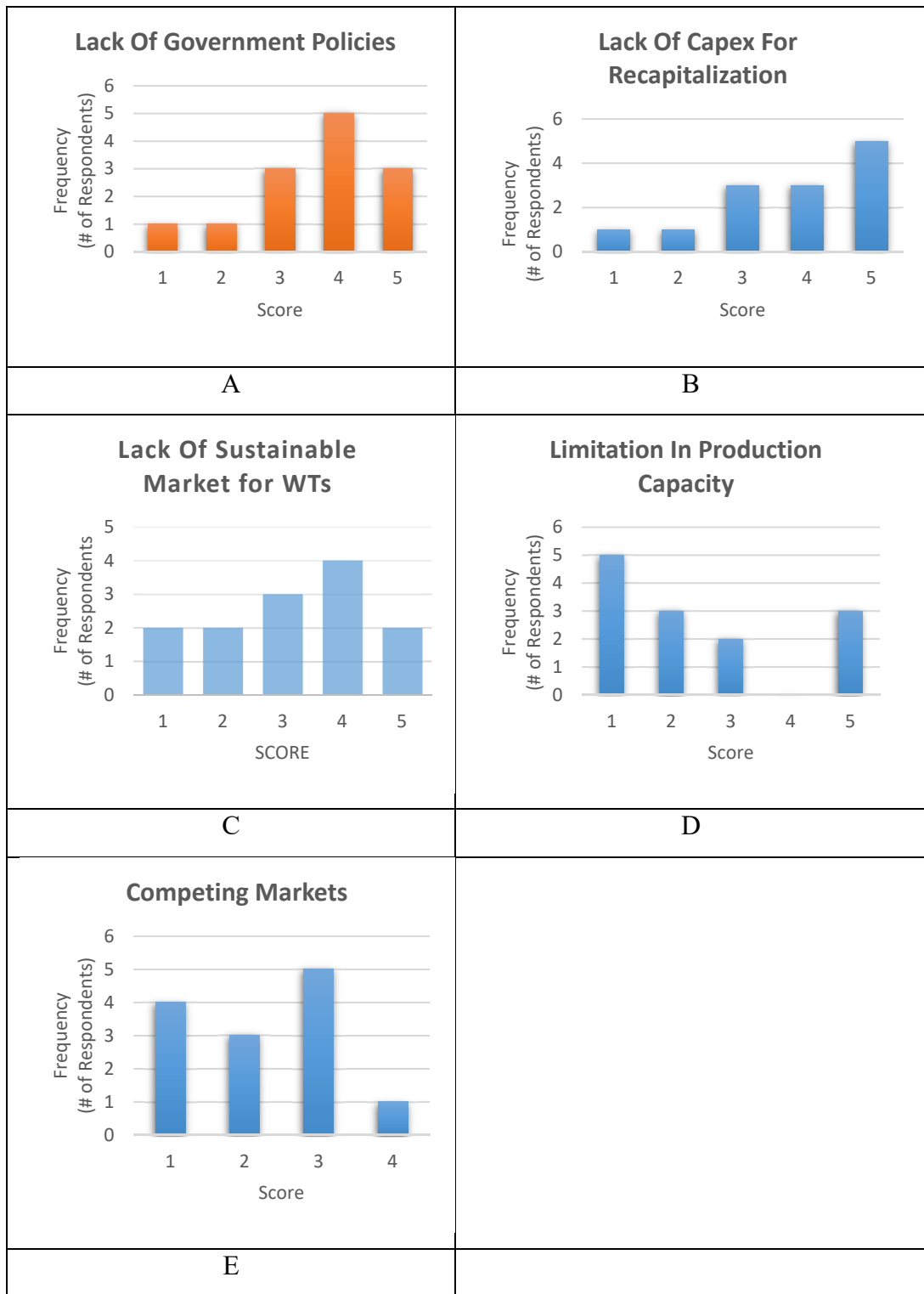

**Figure 31:** Gaps in The Participation of Local Companies In WT Manufacturing

The gaps were given a score from one to five where one means very low priority, two means low priority, three means moderate, four means high priority and five means very high priority. Very high priority means that the gap being investigated has a very high adverse effect if not addressed.

From Figure 31-A, five respondents indicated that Lack of Government Policies should have a high priority, three ranked the gap as very high priority, another three ranked it moderate. One respondent ranked the gap as low while another one ranked it as very low. In Figure 31-B, five respondents ranked the Gap for Lack of Capex for Recapitalization as very high. Three respondents ranked the gap as high and another three ranked it as moderate. One respondent ranked the gap as low while another one ranked it as very low.

In Figure 31-C, four respondents ranked the gap for Sustainable Market for WTs as high priority while three ranked it as moderate. Two ranked the gap as very high, another two ranked it as low a further two ranked it as very low. In Figure 31-D, five respondents ranked the gap for Limitation in Production Capacity as very low priority. Three ranked the gap as very high while another two ranked it as low. Two respondents ranked the gap as moderate and none ranked it as high. In Figure 31-E, five ranked the gap for Competing Markets as moderate priority, four ranked it as very low and three ranked it as low. One respondent ranked the impact of competing markets as high while none ranked it as very high.

## CHAPTER FIVE: DISCUSSION

This chapter presents the discussions which were conducted on the results obtained from the survey. These discussions were conducted in accordance with the specific objectives of the study namely a) to review the wind potential for grid-scale wind power development in Zambia, b) to assess the capacity of Zambian industries to manufacture grid-scale WT blades and towers, c) to identify pertinent gaps to be prioritised in order to enhance the local industry capacity.

### 5.1 Wind Potential for Wind Power Development in Zambia

Three wind resource assessment projects were thoroughly reviewed during this study. The findings of these projects indicate that there is definite wind resource potential in certain parts of Zambia for grid-scale wind power generation. According to DNV-Gl, long term adjusted wind data at 80 m above ground level indicated annual average wind speeds in excess of 6 m/s from six of the eight sites. This is adequate to sustainably operate a Class IV WT with an 80 m hub height. However, at the same hub height the annual average wind speeds are too low to sustain a Class III WT. The extrapolated wind data for the eight sites indicate that a Class III Turbine with a 130 m hub height can operate sustainably at four of the eight sites, whereas a Class IV Turbine with the same hub height can operate sustainably at all the sites.

The study by TDAU indicated that annual average wind speeds of 6.8 m/s at 117 m are available in Kasomalunga, this is adequate to sustainably operate a Class IV WT but not a Class III unless at a higher height. The annual average wind speeds obtained by RINA in Namalundu indicate average wind speeds of 5.2 m/s at 95 m above ground level, this is not adequate to sustainably operate a Class IV WT.

The above studies have shown that a Class IV WT with hub height in excess of 117 m can be operated sustainably at nine of the ten sites under investigation. Further, at least four of the ten sites can operate a Class III WT with a hub height of 130 m. Despite all sites being capable of sustaining a Class IV WT it is more economical to focus on those which can sustain a Class III WT. According to *LM Wind Power*, there is a clear trend in the market toward more Wind Class III turbines in low wind sites (*LM Wind Power*, n.d.). The effect of the above situation has resulted in a bias among WT manufacturers to produce Class III WTs. This in turn lowers the initial cost of WTs due to economies of scale and competition among manufacturers. In 2010 *Wiley*

predicated that larger machines beyond 5 MW should become economically viable with further advances in material and design technology, but a sudden change is unlikely over the next 5-year period (Willey, 2010). This prediction was accurate, as 10 years today the most common turbine sizes for on shore applications are within the 2-5 MW rating. Considering the above explanations, this study adopted a Class III WT with hub height of 130 m and maximum rated capacity of 4 MW for the Zambian wind regime.

## **5.2 Capacity of Zambian Manufacturing Industries to Manufacture Grid-Scale Wind Turbine Blades and Towers**

### **5.2.1 WT Blade Manufacturing**

The results from the survey indicate that 17 % of the companies that took part in the survey manufacture GFRP products. This process is very similar to the one used in WT blades except for the scale and quality requirements for the latter. In order to achieve superior quality, blade manufacturers employ a process called polymer infusion where the polymer is spread consistently throughout the glass fibres with the help of an artificially created vacuum. This part of the process is not currently practiced in the Zambian GFRP production processes. The processes currently being practiced are rudimentary due to the nature of the products being manufactured.

The results from the survey indicate that 67 % of the companies that responded to the survey occupy an area greater than one hectare. A one-hectare area is adequate to house all the necessary infrastructure required for manufacturing grid-scale WT blades. However, only 33 % of the companies have adequate sheltered space to accommodate a mould measuring 75 m long and up to 4.5 m wide. Further, it should be noted that most of this infrastructure is old and was not meant for WT blade manufacturing hence it lacks some of the supplementary equipment such as overhead cranes.

In order for these companies to be able to manufacture grid-scale WT blades, they need to invest in upgrading their infrastructure and equipment. Infrastructural upgrades should include strengthening the floor to handle heavy duty applications and extensions where necessary to accommodate WT blade mould. Equipment upgrades should include acquisition of equipment such as WT blade moulds, overhead cranes or similar combination. On the personnel side there will be need to train engineers and technicians on the processes and how to operate the new equipment.

### 5.2.2 Tower Manufacturing

The study considered three types of towers namely steel tubular, steel lattice and concrete towers. Note that the information on these three tower types was to discuss hybrid towers. The results for each type of tower are discussed in the subsequent paragraphs.

The results in Chapter Four indicate that 28 % of the respondents occupy an area greater than 1.5 ha while 43 % occupy an area greater than 0.7 ha but less than 1.5 ha and 29 % occupy an area less than 0.7 ha. These results imply that 29 % of the respondents do not have adequate land requirements to manufacture either steel tubular towers or lattice towers. Further, 71 % satisfy land requirements in order to manufacture steel tubular towers and 28 % have adequate land requirements to manufacture the steel lattice towers. It should be noted that the land being referred to in this study is the land currently owned by the respondents.

Information on available infrastructure was challenging as most of the respondents could not avail technical details of their infrastructures. This made it challenging to determine the size of the infrastructure and supplementary equipment. From the few that responded, the results revealed that the largest sheltered infrastructure measured 15 m by 100 m. The length of such a structure may be adequate for manufacturing both the tubular tower and lattice tower sections, however it may be too narrow for fabrication of the tubular tower sections. Therefore, the structure needs to be modified in order to satisfy the requirements for manufacturing steel tubular towers. Just like blade manufacturing, it should be noted that these structures may not have been built for heavy applications such as those involved in WT tower manufacturing and therefore cannot be used for WT tower manufacturing on as-is basis.

The results in Chapter Four indicate that 57 % of the respondents can cut 25 mm thick steel plates, 29 % can weld together 25 mm thick steel plates and 71 % can conduct surface finishing operations on steel surfaces. There are no respondents who have capacity to conduct rolling or bending operations on 25 mm thick steel plates. The biggest roll/bending equipment can only bend up to 16 mm thick plates. The literature reveal has indicated that this size of plates can only be uses for top sections of the tower. Therefore, it has been deduced that on as-is basis there is no company which can manufacture steel tubular tower sections for the full tower height. Despite that 57

% of the respondents can cut 25 mm thick plates, the equipment available are rudimentary as the survey indicated that they would use either oxy-acetylene or plasma cutting equipment which are manually operated. This will have a negative effect on the quality of the towers hence more time will be spent on the process thereby reducing the productivity while raising the cost of production. CNC cutting technologies are best suited for this kind of cutting operations as they are capable of making high precision cuts with increased productivity at a lowered cost of production. This is in agreement with *Sainz* who stated that Increased automation technology in wind turbine manufacturing process is a laborious alternative and requiring substantial financial investment, but it achieves simplicity, economy and increases the final quality of each turbine (*Sainz, 2015*). The survey revealed that the 71 % of respondents who can conduct surface finish listed sand blasting and spray painting for cleaning and painting operations respectively. The mentioned operations are both manually operated and this may have an advantage on quality control over automated operations, as human intervention can be introduced earlier in the process improving the finish quality.

In order for these companies to be able to manufacture steel tubular towers they need to acquire roll/bending equipment which can handle plates up to 25 mm thick. Further, they need to acquire ancillary equipment such as automated cutting machines.

The results from the survey indicate that 14 % of the respondents have equipment to straighten angle bars measuring 150 mm by 150 mm before further processing. The equipment which was mentioned for angle bar straightening is a press machine. This machine is not meant for angle straightening at mass production scale such as would be involved in grid-scale WT lattice tower manufacture. The roller type straightening equipment are more ideal for large scale application. There are no respondents that possessed this type of equipment. Therefore, it would be a challenge to straighten the angle bars on a large scale.

The survey further indicated that 29 % of the respondents can cut angle bars measuring 150 mm by 150 mm into required lengths and 14 % of the respondents are capable of punching holes into angle bars according to specifications. The available equipment for cutting angle bars are the profile cutter, power saw and guillotine. All the three equipment mentioned are operated manually therefore the productivity is low and may lead to increased cost of production for large scale application such as WT lattice

towers. It would be more practical to employ CNC/NC equipment for such application as this will be less labour intensive but highly productive. Two types of machines which have been mentioned for punching holes are the press machine equipped with punching dies and a drilling machine. The latter may not be practical for WT lattice tower manufacturing due to its low productivity and the fact that it is not automated means that it is labour intensive. The press machines equipped with punching dies is preferred over the drilling machine as it has a higher productivity even when it is not automated. CNC/NC are best suited for cutting and punching angle bars at a large scale such as this. There was no respondent who had a galvanising plant, this means that despite some companies being able to cut and punch angle bars the process is not complete if the sections are not galvanized according to design specifications for corrosion protection. Therefore, there are no companies which can manufacture grid-scale WT lattice towers on as-is basis. In order for these companies to be able to manufacture steel tubular towers they need to acquire galvanising equipment as well as automated angle iron cutting and punching machines.

It should be noted that if Design for Manufacture and Assembly (DFMA) principles are applied, it is possible to design a hybrid tower which utilises concrete lower sections and steel tubular upper sections. The steel tubular section design should use 16 mm plates so that it can be manufactured locally as the equipment to roll/bend the plates is available. The concrete sections only require a mould, this can be designed and manufactured locally.

### **5.3 Gaps to be Prioritised in Order to Enhance the Local Industry Capacity**

The study investigated gaps which need to be prioritised if local industries have to participate in WT manufacturing. The gaps were identified from findings of similar studies in the region. This study focused on five gaps namely lack of government policies, lack of capex for recapitalization, lack of sustainable market for WTs, limitation in production capacity and competing markets. These gaps cut across four main sectors namely policy, financial, economic and technical.

Government policies create an enabling environment which facilitate the establishment and growth of entrepreneurship in a particular sector. Therefore, lack of favourable government policies in a particular sector entails that there will be a lot of challenges in executing projects in that sector. The results from the study ranked the

lack of government policies as a high priority gap, this is because there are no wind power policies in place at the moment in Zambia. The wind power sector in Zambia is in its cradle hence the absence of appropriate policies however this is the best time to formulate these policies so that there is clear guidance and motivation for companies who wish to venture into this sector.

The study investigated the gap for lack of capex for recapitalization, this gap is very significant especially that this study has already suggested that all the industries which need to venture into WT manufacturing need to recapitalize. The results from this study indicate that the gap for lack of capex for recapitalization is a very high priority gap. This was expected as the results from the technical section of this study suggest that on as-is basis, there are no Zambian companies which can manufacture grid-scale WT blades or towers unless major overhauls are conducted on their infrastructure. It will be impossible for these companies to finance this scale of recapitalization on their own.

A sustainable market is very significant in any business; it ensures that the products being produced will be sold at a rate which will enable the company to recoup its investment. Therefore, the lack of a sustainable market for WTs will result in companies making losses and eventual closure. The results from the study indicate that the gap for sustainable market is a high priority. This is because the wind energy sector in Zambia is new with no grid-scale wind farms installed at the moment, therefore the demand for WTs only exist in potential form and it is not certain. It is a matter of logic that the creation of a sustainable market for WTs is given a high priority in order to safeguard the investment of companies which will venture into the sector.

This study investigated companies which are already in existence and are conducting business. Therefore, introduction of a new product on their production line will spontaneously introduce a competing market to the existing one. The study ranked the gap for competing markets as moderate, this is with the view that most of these companies will have to establish new infrastructure for WT manufacturing. This will not affect their current production as the existing infrastructure will continue to supply the demands for existing markets.

## CHAPTER SIX: CONCLUSIONS AND RECOMMENDATIONS

### 6.1 Conclusions

The wind resource assessment projects being undertaken in Zambia have demonstrated that there is wind resource potential for grid-scale wind power generation in certain parts of Zambia. These studies have shown that a Class IV WT with hub height in excess of 117 m can be operated sustainably at 90 % of the sites under investigation. Further, at least 40 % of these sites can operate a Class III WT with a hub height of 130 m. Due to economic reasons, this study adopted a Class III WT with hub height of 130 m and maximum rated capacity of 4 MW for the Zambian wind regime.

The study has revealed that 67 % of the polymer manufacturing companies that took part in the survey have adequate space required to manufacture WT blades. However, only 33 % of the companies have adequate sheltered space to accommodate a grid-scale WT blade mould system. Furthermore, it was noted that all the available infrastructures were not meant for WT blade manufacturing hence the lack some of the supplementary equipment such as overhead cranes. The study revealed that only 17 % of the companies that took part in the survey manufacture GFRP products. Despite the process being very similar to the one used in WT blades, the processes currently being practiced are rudimentary and highly labour intensive hence cannot be directly used for grid-scale WT manufacture.

The study has revealed that 71 % of the mechanical engineering companies who took part in this study satisfy land requirements to manufacture steel tubular towers and 28 % have adequate land requirements to manufacture either the Steel Lattice towers or Steel Tubular towers. Despite that 57 % of the companies can cut 25 mm thick steel plates, only 29 % can weld together 25 mm thick steel plates. Although 71 % can conduct surface finishing operations on steel surfaces, there are no companies with capacity to conduct rolling or bending operations on 25 mm thick steel plates into circular sections for making steel tubular towers. In addition, it was noted that the equipment currently available are labour intensive as they are all manually operated.

A survey on capability of companies to manufacture Steel Lattice towers has revealed that 14 % of the companies have equipment to straighten angle bars, 29 % can cut angle bars into required lengths and 14 % are capable of punching holes into angle

bars. However, the equipment mentioned for conducting the above operations may not be suitable for mass production of grid-scale WT lattice towers because the equipment is highly labour intensive therefore productivity will be low and may lead to increased cost of production for large scale application such as WT lattice towers. There is no company which has a galvanising plant in Zambia, therefore the galvanising process cannot be conducted locally.

A survey on gap assessment has indicated that there are some gaps in policy, financial, economic and technical areas that need to be prioritized in order to enhance the capability of local industries to manufacture WT blades and towers. The study has ranked the formulation of governmental policies as high priority, these policies will create a suitable environment for the local companies to manufacture WT blades and towers. On the financial gap, lack of capex for recapitalization was ranked as a very high priority; this correlate with the technical findings of this study which suggest that companies have to conduct major overhauls in order to manufacture WT blades and towers. The gap for sustainable market for WTs was ranked as a high priority.

Therefore, the findings of this study indicate that on an as-is basis there are no companies in Zambia which can manufacture WT blades or towers unless infrastructural and equipment upgrades as well as personnel capacity building are conducted. However, applying a DFM approach hybrid towers of concrete lower sections and steel tubular upper sections can be designed to be manufactured using currently available infrastructure and equipment. Further, several gaps have been identified and given a priority ranking indicating which gaps should be considered more thoughtfully.

## **6.2 Recommendations**

Grid-scale wind power generation is possible in certain parts of Zambia, however, this industry is still in its cradle and requires a lot of nurturing if it's true potential is to be realised. This study makes the following recommendations to develop the wind power industry:

- a) There is need to design a concrete-steel tubular hybrid tower with a hub height of 130 m utilising DFMA principles;

- b) For the tower in a) there is need to design a concrete mould system for the tower sections, the mould should be portable using conventional vehicles so as the casting can be done on site;
- c) The Government of Zambia should formulate policies which will create a suitable environment for wind power developments which will in turn create a sustainable market for local WT blades and towers;
- d) The Government of Zambia should formulate policies which will create a suitable environment for companies wishing to venture into local WT blade and tower manufacturing;
- e) The Governmental of Zambia should facilitate the installation of at least one wind farm as proof of concept;
- f) Financial institutions in conjunction with the Government of Zambia should formulate financing mechanisms and/or fiscal incentives to attract would be local WT blade and tower manufacturers;
- g) A study on the current electricity grid network should be conducted and possible upgrades suggested in order to facilitate power take-off from the wind farms;
- h) A holistic study on the capacity of Zambian haulage industry to haul WT components such as tower sections, blades, nacelle, generators, gear boxes, etc. should be undertaken.

## REFERENCES

- Ace-Doran, 2017. *Doran Doran*. [Online]  
Available at: <http://www.acedoran.com>  
[Accessed 21 11 2017].
- AlBat'hi, S. A., Buys, Y. F. & Hadzari, m. H., 2015. A Light Material for Wind Turbine Blades. *ResearchGate*, Volume 1115, pp. 308-313.
- Bassyouni, M. & Gutub, S. A., 2013. Materials Selection Strategy and Surface Treatment of PolymerComposites For Wind Turbine Blades Fabrication. *Research Gate*, 21(17), pp. 463-472.
- Det Norske Veritas, 2010. *Standard DNV-DS-J102*. Bærum: Det Norske Veritas.
- DNV-GL, 2016. *Wind Resource Mapping in Zambia: Phase 2 Implementation*, Washington DC: World Bank.
- DNV-GL, 2018. *Wind Resource Mapping in Zambia - 12 Month Site Resource Report*, Washington DC: World Bank.
- Eanest, J. & Wizelius, T., 2011. *Wind Power Plants and Project Development*. Eastern Economy Edition ed. New Dheli: PHI Learning Private Limited.
- Enerst, J., 2014. *Wind Power Technology*. New Dheli: PHI Learning Private Limited.
- Esser-Systems, 2018. *Esser-Systems*. [Online]  
Available at: [esser-systems.com](http://esser-systems.com)  
[Accessed 11 02 2018].
- GWEC, 2017. *Global Wind Energy Council*. [Online]  
Available at: <http://www.gwec.net>
- IRENA, 2012. *RENEWABLE ENERGY TECHNOLOGIES: COST ANALYSIS SERIES, Vol 1, Power Sector, Issue 5/5, Wind Power*, s.l.: s.n.
- Kaluminiana, O. S., n.d. *Measures to Diversify the Power Sector in Zambia*. Lusaka: Department of Energy.
- Kothari, C., 2004. *Research Methodolgy: Methods and Techniques*. Revised Second Edition ed. New Dheli: New Age International (P) Limited.
- LM Wind Power, n.d. *What is a Wind Class*. [Online]  
Available at: <https://www.lmwindpower.com/en/stories-and-press/stories/learn-about-wind/what-is-a-wind-class>  
[Accessed 08 September 2018].
- Maritz, j., 2011. *SA's First wind Turbine Manufacturer Gearing up for Production*. [Online]  
Available at: <https://www.howwemadeitinafrica.com>  
[Accessed 11 August 2018].
- Mishnaevsky Jr, L. et al., 2017. Materials for wind Turbione Blades. *Materials - MDPI*, 10(1285).

Mohan Das, P. & Amano, R., 2014. Chapter 2 - Basic Theory for Wind Turbine Blade Aerodynamics. In: R. Amano & B. Sundén, eds. *Aerodynamics of Wind Turbines*. Boston: WIT Press, pp. 11-23.

NASA, n.d. *Incorrect Theory #1*. [Online]

Available at: <https://www.grc.nasa.gov/www/k-12/airplane/wrong1.html>

[Accessed 29 01 2019].

Newen, n.d. *Wind Turbine*. [Online]

Available at: <http://www.newen.ca/wind-turbine-ca.html>

[Accessed 12 06 2017].

NRG Systems, 2018. *Wind Resource Assessment Trends in wind Measurements in Pre-Construction and Post-Construction Projects*. Singapore, Asia Wind Energy Association.

RINA, 2018. *KGRTC Wind Farm - Feasibility Report*, Chikankata: KGRTC.

Sainz, J., 2015. New Wind Turbine Manufacturing Techniques. *Procedia Engineering - Elsevier*, Issue 135, pp. 880-886.

Sandia National Laboratories, unkwon. *Research Directions in Wind Turbine Blades: Materials and Fatigue*. Stanford, GCEP - Stanford.

SSP-Technology, 2017. *SSP Technology*. [Online]

Available at: <http://ssptech.com>

[Accessed 15 12 2017].

Sungjin, L., Chungduk, K. & Huynbum, P., 2013. A Study on Optimal Design of Filament Winding Composite Tower for 2 MW Class Horizontal Axis Wind Turbine Systems. *International Journal of Composite Materials*, 3(1), pp. 15-23.

TDAU, 2016. *Reconnaissance Survey report*, Lusaka: REA.

TDAU, 2018. *Wind Resource Assessment in Lunga - Technical Feasibility*, Lusaka: Rural Electrification Authority.

The DTI, SA, 2012. *The Wind Energy Industry Localisation Roadmap in Support of Large-Scale Roll-Out in South Africa*, s.l.: s.n.

Vestas, 2017. *MHI Vestas Offshore Wind*. [Online]

Available at: <http://www.mhivestasoffshore.com/new-24-hour-record/>

Vestas, 2018. *Vestas*. [Online]

Available at: [https://www.vestas.com/en/products/turbines/v150-4\\_2\\_mw#!](https://www.vestas.com/en/products/turbines/v150-4_2_mw#!)

[Accessed 21 July 2018].

Vries, E. d., 2011. *Close up - LM's 73.5-metre blade*. [Online]

Available at: <https://www.windpowermonthly.com>

[Accessed 07 06 2017].

Wiley, L. D., 2010. Chapter 6 - Design and Development of MeggaWat Wind Turbines. In: W. Tong, ed. *Wind Power Generation and Wind Turbine Design*. Boston: WIT Press, pp. 187-256.

Wind Prospect, n.d. *Wind Prospect*. [Online]  
Available at: <https://www.windprospect.com>  
[Accessed 02 February 2017].

Wind Prospects, 2016. *Supply and Installation of Wind Resource Assessment Equipment and Provision of Technical Support for Actual Wind Measurements at the KGRTC: Feasibility Report*, Chikankata: KGRTC.

Wizelius, T., 2009. *Developing Wind Power Projects - Theory and Practice*. London: Earthscan.

ZDA, 2014. *Energy Sector Profile*. Lusaka: Zambia Development Agency.

## APPENDICES

**APPENDIX I: PAPER PUBLISHED IN THE 4<sup>TH</sup> AFRICA ENGINEERING CONFERENCE BOOK OF PROCEEDINGS**

UNESCO 6<sup>th</sup> Africa Engineering Week and 4<sup>th</sup> Africa Engineering Conference, on the 18<sup>th</sup> – 20<sup>th</sup> September, 2019, at Avani Victoria Falls Resort, Livingstone, Zambia

**A REVIEW OF WIND RESOURCE POTENTIAL FOR GRID-SCALE POWER GENERATION IN ZAMBIA**

Amos Banda<sup>1</sup>, Leonard Simukoko<sup>2</sup>, Henry M. Mwenda<sup>3</sup>

**Abstract**

The Zambian electricity grid system has been dominated by hydropower at 96%, 2.1% thermal and 1.7% renewable (Kaluminiana, n.d.). During the 2014/2015 rainy season, Zambia received very low rains which led to reduced electricity production at the two major power plants. In light of this situation, there was a push towards diversification in the power generation mix to achieve a more resilient system. This quest for diversification has led to the inception of grid-scale wind power feasibility studies at ten sites distributed around the country. These feasibility studies intend to establish the availability of the wind resource for grid-scale power generation, this will foresee the development of the wind power industry in Zambia.

This paper conducted a thorough review of the above feasibility studies and gives the current status of wind resource potential for grid-scale power generation in Zambia. The three wind resource assessment projects being undertaken in Zambia have demonstrated that there is wind resource potential in certain parts of Zambia for grid-scale wind power generation. These studies have shown that a Class IV WT with hub height in excess of 117m can be operated sustainably at nine of the ten sites. Further, at least five of the ten sites can operate a Class III WT with a hub height of 130m. Due to economic reasons, this paper proposed a Class III WT with hub height of 130m and maximum rated capacity of 4MW WT for the Zambian wind regime.

**Keywords:** Review, Wind-Resource, Grid-Scale, Zambia

**1. Introduction**

The Zambian electricity grid system has been dominated by hydropower at 96%, 2.1% thermal and 1.7% renewable (Kaluminiana, n.d.). The renewables only comprise of solar and small hydro-power plants. During the 2014/2015 rainy season, Zambia

---

<sup>1</sup>University of Zambia, Technology Development and Advisory Unit, [amos.banda@unza.zm](mailto:amos.banda@unza.zm),

<sup>2</sup>University of Zambia, Technology Development and Advisory Unit, [leonard.simukoko@unza.zm](mailto:leonard.simukoko@unza.zm),

<sup>3</sup>University of Zambia, School of Engineering, Dept of Mechanical Engineering, [hm.mwenda@unza.zm](mailto:hm.mwenda@unza.zm)

received very low rains which led to reduced electricity production at the two major power plants. This led to massive load-shedding in an attempt manage the insufficient power being produced. In light of this situation, there was a push towards diversification in the power generation mix which will be more resilient to climate factors due to the compensating nature of this system.

The quest to diversify the power generation mix has led to the commissioning of several power projects such the Maamba Thermal Plant, Grid-scale solar plants and several hydro power plants. This quest for diversification has further led to the inception of grid-scale wind power feasibility studies at a total of ten sites distributed around the country. These feasibility studies intend to establish the availability of the wind resource for grid-scale power generation, this will foresee the development of the wind power industry in Zambia.

This paper is a systematic review of the results from the above studies and gives the current status of wind resource potential for grid-scale power generation in Zambia. The paper discusses the International Electro-Technical Commission (IEC) Wind Turbine Classes in section two, the status of wind resource potential is discussed in section three and section four presents the concluding remarks.

## 2. IEC Wind Turbine Classes

A Wind Turbine (WT) operates on a reverse principle of a fan in that it uses the kinetic energy contained in the wind to turn propeller-like blades around a rotor. The rotor is connected to the main shaft, which spins a generator to create electricity. WTs comes in different sizes and classes, the IEC has established wind turbine classes to be applied for standardization and certification of wind turbines. These classes are numbered from Class I for highest winds and Class IV for sites with very low winds as shown in Table 1 below.

**Table 1:** Wind Turbine Classes (Eanest & Wizelius, 2011)

	Wind Turbine Classes				S
	I	II	III	IV	
$V_{ref}$	50	42.5	37.5	30	Values to be pecified by the
$V_{av}$	10	8.5	7.5	6	
$A_{/15}$	0.18	0.18	0.18	0.18	
<b>a</b>	2	2	2	2	
$B_{/15}$	0.16	0.16	0.16	0.16	
<b>a</b>	3	3	3	3	

*Note: the values apply at hub height and ‘A’ designates higher turbulence, ‘B’ designates lower turbulence. The subscript ‘/15’ is the turbulence intensity at 15m/s, ‘a’ is the slope parameter in the Normal Turbulence Model equation.*

The table above has become handy for both turbine manufacturers and wind farm developers with regard to types of turbines. For example, for a site with low average wind speeds of 6m/s, it makes economic sense to install Class IV wind turbines which has low average operating speeds. In addition to winds speeds, the table provides the turbulence survivability of a turbine in each class at a turbulence intensity of 15m/s. The Class S WTs have customized parameters to suit a site that does not fit in Classes I to IV.

### **3. Status of Wind Resource Potential in Zambia**

Zambia is a new market to wind power and there are currently no installed wind farms. The major challenge that has faced wind power development in Zambia is the lack of appropriate and industry standard wind data. The available wind data has been recorded for over 30 years and was intended for agricultural and weather focusing purpose. The Zambia Metrological Department (ZMD) has been the responsible department for recording and analysing the wind data. This data was mainly recorded at 2m heights with later sites measuring at 10m heights such as the one in figure 1 below.



**Figure 1:** A 10m Met mast in Samfya installed under the SASSCAL program

The later equipment provides better wind data quality compared to the older analogy/manual systems. The later systems are fully automated and record data every 10 minutes on a daily basis, this data is remotely accessed via internet. There are 10 of these systems installed around the country. Wind data collected at 10 meters above the ground indicate speeds of between 0.1 to 3.5 m/s with an annual average of 2.5 m/s (ZDA, 2014). It should be noted that the wind data referred to was not intended for grid-scale wind power generation. It can therefore be deduced that the methods used to obtain and analyse this wind data does not conform to the wind power industry practice. Therefore, this data cannot be exclusively used to determine whether the wind resource is adequate for grid-scale wind power generation, however, it can be used to locate potential sites for detailed feasibility studies.

In the absence of adequate ground measured wind data, a number of meta-data sets can be used to establish the wind resource for any area of interest. These data sets are generated from satellite data and wind data from nearby meteorological stations. The IRENA Global Wind Atlas is a wind map which was generated using meta-data. The IRENA global wind atlas shown in the figure below indicates presence of some areas within Zambia with annual wind speeds of around 7m/s at 80m heights.

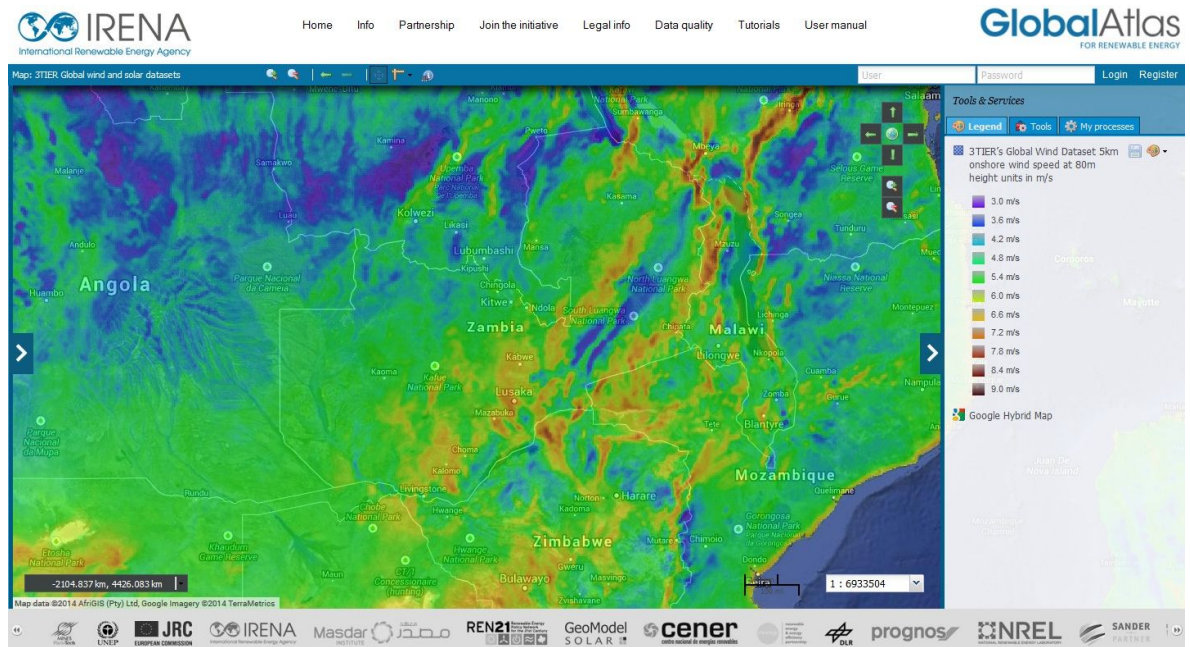

**Figure 2:** Global Wind Atlas showing wind speed distribution in Zambia (IRENA, 2014)

The wind atlas is generated from satellite data and wind data from meteorological stations on the ground, however, the uncertainty can be as high as 10%, this will impact the accuracy of annual energy production (AEP) estimation, overall risk, and funding. On-site measurement can reduce uncertainty by more than 50% over models derived from satellite data alone (NRG Systems, 2018). It is against this background that the Department of Energy and the World Bank commissioned a project to validate the national wind atlas. The final, validated, peer reviewed output from this project will be the Zambia Wind Atlas, which will be published by the World Bank once the project is completed (DNV-GL, 2016). The findings of this project will help determine viability of wind power development in terms of wind resource.

This exercise involved selection of suitable sites around the country. These sites were chosen such that they represent national coverage at the time of Wind Map generation. The sites with the highest potential for wind power development were given highest priority for this exercise. The selection of the sites was based on the industry practice of taking into consideration various factors such as accessibility, grid connection, wind resource, environmental issues, etc. At the end of a rigorous selection process, eight sites were selected.

Wind resource measurements have been recorded at the eight sites using met masts with measurements taken from November 2016 to January 2018 (DNV-GL, 2018). Note that the data recording is still on-going, the captured period was to facilitate an interim data analysis. Wind data was recorded every ten minutes on a daily basis. This data was run through a software to generate various statistical outputs such as annual average wind speed and frequency wind speed distribution for the measuring period. The annual average wind speed is particularly important as it gives the first indicator of the site's resource potential and can be used to decide whether to continue investigating the site or not. The software was further used to apply long term adjustments to the site measured data so as to predict the annual average wind speed for the project life. To obtain a refined picture of the resource the wind speeds are extrapolated to turbine hub height. The exercise considered a theoretical 4MW turbine with hub-height 130m, therefore, the wind data was extrapolated to 130m and the long term adjustments were applied. Table 2 below shows the annual average wind speeds for the eight sites.

**Table 2:** Summary of Annual Average Wind Speeds at 80m and 130m (DNV-GL, 2018)

Site	Measured Wind Speed @80m	Long Term Adjusted Wind Speed @80m	Extrapolated Wind Speed @130m	Long Term Adjusted Wind Speed @130m
Choma	6.5m/s	6.6m/s	7.4m/s	7.4m/s
Mwinilunga	6.0m/s	6.0m/s	7.4m/s	7.5m/s
Lusaka	6.2m/s	6.5m/s	7.9m/s	8.2m/s
Mpika	6.2m/s	6.3m/s	7.3m/s	7.3m/s
Chanka	6.5m/s	6.6m/s	7.4m/s	7.5m/s
Petauke	5.7m/s	5.7m/s	6.5m/s	7.0m/s
Mansa	5.8m/s	5.9m/s	6.9m/s	7.3m/s
Malawi	5.8m/s	5.8m/s	6.9m/s	7.1m/s

From the annual average wind speeds shown in the table above it can be deduced that at 80m height eight of the ten sites have Class IV wind speeds, two have wind speeds below Class IV and none have Class III wind speeds. However, at a much higher height of 130 the scenario is different as four site experience Class III wind speeds while the remaining six experience Class IV wind speeds. The long term adjusted wind data at 80m above ground level indicated annual average wind speeds in excess of 6m/s from six of the eight sites, this is adequate to sustainably operate a Class IV WT with an 80m hub height. However, at the same hub height the annual average wind speeds are too low to sustain a Class III WT. The extrapolated wind data for the eight sites indicate that a Class III Turbine with a 130m hub height can operate sustainably in four of the eight sites whereas a Class IV Turbine with the same hub height can operate sustainably at all the sites.

This project is still on going with a final analysis to be conducted at 24months of data collection, the results of the final analysis are not expected to deviate significantly from the interim analysis. The findings of the interim analysis indicate that the potential for commercial scale wind power is available in Zambia.

There are two other feasibility studies which have been conducted in Zambia by different institutions. The final outputs from these studies are feasibility reports on development of wind power at the specific sites. The feasibility assessments in these

projects were detailed and took into consideration wind resource, environmental issues, constructability and grid connectivity (Wind Prospects, 2016) (TDAU, 2016).

The aim of the study conducted by RINA on behalf of Kafue Gorge Regional Training Centre (KGRTC) aimed at installing a mast and conducting a feasibility of installing a single WTG at a site within the Kafue Gorge. The proposed WTG is of grid-scale despite that its main purpose will be for training applications. The 60m mast was installed in February and data collection commenced on 7<sup>th</sup> February 2017.

At the time of the EYA, a total of 13.5 months of locally measured data was available for processing. The data was processed in accordance with the IEC guidelines and the results are shown in table 3 below.

**Table 3:** Summary of Wind Data from KGRTC Mast (RINA, 2018)

Measured Wind Speed @60m	Long Term Adjusted Wind Speed @60m	Long Term Adjusted Wind Speed @95m
4.48m/s	4.52m/s	5.2m/s

The annual average wind speed for this site at 95m agl is below Class IV wind speeds and may not be viable for grid-scale wind power generation. However, it should be noted that if a higher height is considered, the site may experience Class IV wind. The annual average wind speeds obtained in Namalundu indicate average wind speeds of 5.2m/s at 95m above ground level, this is not adequate to sustainably operate a Class IV WT.

A similar study was conducted by Technology Development and Advisory Unit (TDAU) for Rural Electrification Authority (REA). The aim of the study was to assess the wind resource potential in Kasomalunga for possible wind-solar hybrid power generation for an isolated min-grid for the island (TDAU, 2016). The overall intention of the study was to assess the resource potential for small WTs for a 300kW mini grid, however TDAU went a step further to include the analysis for grid-scale WTs. Just like the RINA study, a 60m Mast was installed with anemometers at 40m, 50m and 60m. Two anemometers were installed at 60m and 50m, a barometer and temperature sensor were installed at 4m. The mast was commissioned on 27<sup>th</sup> February 2017. Figure 3 shows the NRG 60m mast installed at Kasomalunga in Luapula.



**Figure 3:** The NRG 60m mast installed at Kasomalunga in Luapula.

At the time of the EYA a total of 12.7 months locally measured data was available for processing. The study came up with two scenarios for the EYA, Scenario I included two smaller Vergnet GEV MP200 turbines which would be more practical for the mini-grid. Scenario II included two large Vestas V117 Turbines, this was done to indicate the potential for grid-scale wind power at the site and surrounding areas. The turbines for Scenario I had a hub height of 60m whereas those for Scenario II had a hub height of 116.5m. The data collected from the site was processed in accordance with the IEC guidelines and the results are shown in table 4 below.

**Table 4:** Summary of Wind Data from Kasomalunga Mast (TDAU, 2018)

Measured Wind Speed @60m	Long Term Adjusted Wind Speed @60m	Long Term Adjusted Wind Speed @116.5m
5.52m/s	5.4m/s	6.8m/s

The annual average wind speed at 60m height for this site are less than Class IV and may not be viable for grid-scale wind power generation, however the wind speeds may be adequate for an isolated system where energy storage is incorporated. When a higher height of 116.5m was considered, the site was found to experience Class IV wind speeds with a possibility of attaining Class III wind speeds if the height is raised even higher. The annual average wind speeds of 6.8m/s at 117m available in Kasomalunga are adequate to sustainably operate a Class IV WT but not a Class III unless at a higher height.

The findings of these projects indicate that there is definite wind resource potential in certain parts of Zambia for grid-scale wind power generation. The above studies have shown that a Class IV WT with hub height in excess of 117m can be operated sustainably at nine of the ten sites. Further, at least five of the ten sites can operate a Class III WT with a hub height of 130m. Despite almost all sites being capable of sustaining a Class IV WT it is more economical to focus only on those which can sustain a Class III WT. According to *LM Wind Power*, there is a clear trend in the market toward more Wind Class III turbines in low wind sites (LM Wind Power, n.d.). The effect of the above situation has resulted in a bias among WT manufacturers to manufacture Class III WTs, this in turn lowers the initial cost of WTs due to economies of scale and competition among manufacturers. In 2010 *Wiley* predicated that larger machines beyond 5 MW should become economically viable with further advances in material and design technology, but a sudden change is unlikely over the next 5-year period (Willey, 2010). This prediction was accurate, as 8 years today the most common turbine sizes for on shore applications are within the 2-4 MW rating. Considering the above explanations, this paper proposes a Class III WT with hub height of 130m and maximum rated capacity of 4MW for the Zambian wind regime.

#### **4. Conclusion**

The three wind resource assessments projects being undertaken in Zambia have demonstrated that there is wind resource potential in certain parts of Zambia for grid-scale wind power generation. These studies have shown that a Class IV WT with hub height in excess of 117m can be operated sustainably at nine of the ten sites. Further, at least five of the ten sites can operate a Class III WT with a hub height of 130m. Due to economic reasons, this paper proposed a Class III WT with hub height of 130m and maximum rated capacity of 4MW WT for the Zambian wind regime.

## 5. REFERENCES

DNV-GL, 2016. *Wind Resource Mapping in Zambia: Phase 2 Implementation*, Washington DC: World Bank.

DNV-GL, 2018. *Wind Resource Mapping in Zambia - 12 Month Site Resource Report*, Washington DC: World Bank.

Eanest, J. & Wizelius, T., 2011. *Wind Power Plants and Project Development*. Eastern Economy Edition ed. New Dheli: PHI Learning Private Limited.

Kaluminiana, O. S., n.d. *Measures to Diversify the Power Sector in Zambia*. Lusaka: Department of Energy.

LM Wind Power, n.d. *What is a Wind Class*. [Online]  
Available at: <https://www.lmwindpower.com/en/stories-and-press/stories/learn-about-wind/what-is-a-wind-class>  
[Accessed 08 September 2018].

NRG Systems, 2018. *Wind Resource Assessment Trends in wind Measurements in Pre-Construction and Post-Construction Projects*. Singapore, Asia Wind Energy Association.

RINA, 2018. *KGRTC Wind Farm - Feasibility Report*, Chikankata: KGRTC.

TDAU, 2016. *Reconnaissance Survey report*, Lusaka: REA.

TDAU, 2018. *Wind Resource Assessment in Lunga - Technical Feasibility*, Lusaka: Rural Electrification Authority.

Willey, L. D., 2010. Chapter 6 - Design and Development of MeggaWat Wind Turbines. In: W. Tong, ed. *Wind Power Generation and Wind Turbine Design*. Boston: WIT Press, pp. 187-256.

Wind Prospects, 2016. *Supply and Installation of Wind Resource Assessment Equipment and Provision of Technical Support for Actual Wind Measurements at the KGRTC: Feasibility Report*, Chikankata: KGRTC.

ZDA, 2014. *Energy Sector Profile*. Lusaka: Zambia Development Agency.

**APPENDIX II: QUESTIONNAIRE FOR WIND TURBINE BLADE MANUFACTURING**

Thank you for agreeing to be a respondent in this exercise. The purpose of this survey is to investigate and profile the capability of Zambian industries to support local wind power development. Your answers will be confidential and the survey will take approximately 15 minutes to complete.

**SECTION ONE – GENERAL INFORMATION**

1. Does your company manufacture Glass Fibre Reinforced Polymer products?

Yes  No

2. What is the total area of your premises?

a.  $\geq 1$  ha ( one side  $\geq 100$ m)

b.  $\leq 1$  ha

3. Specify the infrastructure on your premises

Type of Infrastructure	Dimensions

4. Any other useful information?

.....  
.....  
.....

*End of section*

**SECTION TWO – TECHNICAL INFORMATION**

5. Does your company have capacity to make moulds measuring up to 75m long and up to 4.5m wide equipped with a polymer infusion machine?

Yes  No

*If the answer to Q5 is yes skip Q6*

6. Can you consider sub-contracting the services in Q5? Yes  No

7. Can your premises accommodate the mould in Q5? Yes  No

8. Do you have equipment to smoothen and clean GFRP surfaces before painting? Yes  No

9. If the answer to Q8 is yes specify the equipment and operator skills

Equipment	Operator skills

10. Do you have equipment to apply polyurethane or epoxy paints to GFRP surfaces?

Yes  No

11. If the answer to Q10 is yes specify the equipment and operator skills

Equipment	Operator skills

12. Any other useful information?

.....  
 .....  
 .....

*End of section*

**SECTION THREE – CONSTRAINTS**

13. On a scale of 1-5 ( 1=least and 5= biggest) what are the anticipated constraints for your company to participate in grid scale wind power industry
- a. Lack of favourable government policies .....
  - b. Lack of capex for recapitalization .....
  - c. Lack of sustainable market .....
  - d. Limitation in production capacity .....
  - e. Competing markets .....

14. Any other useful information?

.....

.....

.....

**End of Questionnaire**

**Thank you for your time**

**APPENDIX III: QUESTIONNAIRE FOR STEEL TOWER MANUFACTURING**

Thank you for agreeing to be a respondent in this exercise. The purpose of this survey is to investigate and profile the capability of Zambian industries to support local wind power development. Your answers will be confidential and the survey will take approximately 20 minutes to complete.

**SECTION ONE: GENERAL INFORMATION**

- 15. What is the total area of your premises?
  - a.  $\geq 1.5$  ha (longest side  $\geq 150$ m and shortest side  $\geq 70$ m)
  - b.  $\geq 0.7$  ha (shortest side  $\geq 50$ m)
  - c.  $\leq 0.7$  ha

16. Specify the infrastructure at your premises

Type of Infrastructure	Dimensions

17. Any other useful information?

.....  
.....  
.....

*End of section*

**SECTION TWO – STEEL TUBULAR TOWERS**

18. Does your company conduct roll/bending operations for steel plates up to 25mm? Yes  No

19. Do you have equipment and skills to handle steel plates up to 25mm? Yes   
No

20. If the answer to Q5 is yes specify the equipment and associated operator skills

Equipment	Operator skills

21. Do you have equipment to cut steel plates up to 25mm thick? Yes  No

22. If the answer to Q7 is yes specify the equipment and associated operator skills

Equipment	Operator skills

23. Can your equipment roll/bend a 25mm thick steel plate up to a diameter of 6m? Yes  No

24. If the answer to Q9 is yes specify the equipment and associated operator skills

Equipment	Operator skills

25. Do you have equipment to weld cylindrical sections with a thickness up to 25mm? Yes  No

26. If the answer to Q11 is yes specify the equipment and associated operator skills

Equipment	Operator skills

27. Do you have equipment to smoothen and clean cylindrical steel surfaces before painting? Yes  No

28. If the answer to Q13 is yes specify the equipment and associated operator skills

Equipment	Operator skills

29. Do you have equipment to apply polyurethane and epoxy paints to steel surfaces?  
Yes  No

30. If the answer to Q22 is yes specify the equipment and associated operator skills

Equipment	Operator skills

31. Any other useful information?

.....  
 .....  
 .....

*End of section*

**SECTION THREE – LATTICE TOWERS**

32. Does your company cut angle bars measuring up to 150x150mm by 10mm thick? Yes  No

33. Do you have equipment and skills to straighten angle bars in Q18? Yes   
No

34. If the answer to Q19 is yes specify the equipment and associated operator skills

Equipment	Operator skills

35. Do you have equipment to cut angle bars in Q18? Yes  No

36. If the answer to Q21 is yes specify the equipment and associated operator skills

Equipment	Operator skills

37. Do you have equipment to punch/drill holes in angle bars in Q18? Yes    
No

38. If the answer to Q23 is yes specify the equipment and associated operator skills

Equipment	Operator skills

39. Does your company have a galvanising plant? Yes  No

40. If the answer to Q25 is yes specify the plant and associated operator skills

Equipment	Operator skills

41. Any other useful information?

.....  
.....

*End of Section*

**SECTION FOUR – CONSTRAINTS**

42. On a scale of 1-5 ( 1=least and 5= biggest) what are the anticipated constraints for your company to participate in grid scale wind power industry

- f. Lack of favourable government policies .....
- g. Lack of capex for recapitalization .....
- h. Lack of sustainable market .....
- i. Limitation in production capacity .....
- j. Competing markets .....

43. Any other useful information?

.....  
.....  
.....

**End of Questionnaire**

**Thank you for your time**

**APPENDIX III: QUESTIONNAIRE FOR CONCRETE TOWER  
MANUFACTURING**

Thank you for agreeing to be a respondent in this exercise. The purpose of this survey is to investigate and profile the capability of Zambian industries to support local wind power development. Your answers will be confidential and the survey will take approximately 15 minutes to complete.

**SECTION ONE – GENERAL INFORMATION**

44. Does your company manufacture pre-fabricated steel reinforced concrete sections?

Yes  No

45. What is the total area of your premises?

- a.  $\geq 1\text{ha}$  (shortest side  $\geq 70\text{m}$ )
- b.  $\leq 1\text{ha}$

46. Specify the infrastructure on your premises

Type of Infrastructure	Dimensions

47. Any other useful information?

.....  
.....  
.....

*End of section*

**SECTION TWO – TECHNICAL INFORMATION**

48. Does your company have capacity to make tapered cylindrical moulds measuring up to 30m high and up to 6m diameter?

Yes  No

*If the answer to Q5 is yes skip Q6*

49. Can you consider sub-contracting the services in Q5? Yes  No

50. Can your casting area accommodate the mould in Q5? Yes  No

51. Do you have equipment to smoothen and clean cylindrical concrete surfaces before painting? Yes  No

52. If the answer to Q8 is yes specify the equipment and operator skills

Equipment	Operator skills

53. Do you have equipment to apply polyurethane or epoxy paints to concrete surfaces?

Yes  No

54. If the answer to Q10 is yes specify the equipment and operator skills

Equipment	Operator skills

55. Any other useful information? 0211840620

.....  
 .....  
 .....

*End of section*

**SECTION THREE – CONSTRAINTS**

56. On a scale of 1-5 ( 1=least and 5= biggest) what are the anticipated constraints for your company to participate in grid scale wind power industry

- k. Lack of favourable government policies .....
- l. Lack of capex for recapitalization .....
- m. Lack of sustainable market .....
- n. Limitation in production capacity .....
- o. Competing markets .....

57. Any other useful information?

.....  
.....  
.....

**End of Questionnaire**

**Thank you for your time**