



THE UNIVERSITY OF ZAMBIA
SCHOOL OF ENGINEERING
DEPARTMENT OF MECHANICAL ENGINEERING

Design Manufacture and Testing Of a 3-Blade Wind
Turbine/Solar Hybrid Generator for Charging Cell Phones

By

Mwaba Musonda Mathew

A dissertation submitted to The University of Zambia in
Partial fulfillment of the requirements for A Master's Degree in Renewable
Energy Engineering

July 2015

DESIGN MANUFACTURE AND TESTING OF A 3-BLADE WIND
TURBINE/SOLAR HYBRID GENERATOR FOR CHARGING CELL PHONES

By

Mwaba Musonda Mathew

A dissertation submitted to The University of Zambia in
Partial fulfillment for A Master's Degree in Renewable Energy Engineering

The University of Zambia
July, 2015

Declaration

I, Mwaba Musonda Mathew, do declare that this work is my own and that the work of other persons utilized in this dissertation has been duly acknowledged. This work presented here has not been previously presented at this or any other university for similar purposes.

Signature: Date.....

Mwaba Musonda Mathew
(Candidate)

We the undersigned have read this dissertation and have approved it for examination;

Dr. H.M Mwenda
Lecturer
Department of Mechanical Engineering
The University of Zambia

Signature:

Date.....

Dr. A. Zulu
Lecturer
Department of Electrical Engineering
The University of Zambia

Signature:

Date.....

© 2015 by Mwaba Musonda Mathew All rights reserved

Approval of Admission of Dissertation

This dissertation by Mwaba Musonda Mathew is in partial fulfillment of the requirements for the award of the Master of Renewable Energy Engineering by The University of Zambia.

Examiners

Name:

Signature:

Date:

Name:

Signature:

Date:

Name:

Signature:

Date:

Head of Department

Name:

Signature:

Date:

Abstract

One of the main factors that led to this research on wind and solar energy hybrid application was the need to empower rural communities with communication technology, namely cellular phones which are now widely used in Zambia. A major constraint to the use of these devices in the rural areas is the poor supply or the complete non availability of reliable electricity supply for recharging the cell phones.

Research has shown that these rural areas despite constituting over 40% of the Zambian population, such population has little or no access to electricity from the national grid system mostly because of the long distances from the grid and the low economic activity in these areas, hence the need for utilization of the locally available energy resources for electricity generation.

In this research the average wind speed was observed to be around 4m/s while the average solar insolation was observed to be above 5 KWh/m²/day. At these figures both the wind and solar components were able to generate more than enough voltage to charge a 12 volt battery and the required number of cell phones at peak demand, while the battery was able to sustain the power requirements at off line periods for both resources. The charge mix controller was also able to control the voltage between the required 12V to 14.7V range during times of excess power generation.

This research has shown that the hybrid setup provides a high level of energy security and that coupled with energy storage namely, the battery, maximum supply reliability and security was ensured. The hybrid system due to the said advantages can be used as main power supply in off grid households, as standby supply in grid connected systems or as part of the grid system to offer more security.

Dedication

This research work is dedicated to my family which has been an inspiration to me throughout my education and especially to my late father Tresford Mwaba who supported and encouraged me to pursue further studies.

Acknowledgements

As with most projects, this research would not have been possible without the help of many people.

I would like to acknowledge my supervisors Dr. H. M. Mwenda and Dr. A. Zulu for all the research advice and support that was given to me during the course of this study. I would like to thank The University of Zambia and specifically the School of Engineering for the opportunity to do this research work. I would also like to acknowledge my friends at Zambian Breweries Ltd for their support and advice during this period. Last but not least I would like to acknowledge my family for being there for me during this period of research and learning.

TABLE OF CONTENTS

	Page
Abstract.....	iv
Acknowledgement.....	v
List of Figures.....	vi
List of Tables.....	vii
List of Symbols.....	viii
List of Equations.....	ix
Acronyms and Abbreviations.....	x

CHAPTER 1: INTRODUCTION

1.1 Introduction.....	1
1.2 Statement Of The Problem.....	3
1.3 Objectives.....	4

CHAPTER 2: LITERATURE REVIEW

2.1 Introduction.....	5
2.2 Renewable Energy Sources.....	5
2.3 Solar Energy.....	6
2.3.1 The Solar Resource.....	6
2.3.2 Photovoltaic Technology.....	8
2.3.3 PV Systems.....	10
2.3.3.1 Setting Up a PV System.....	12
2.3.3.2 Advantages Of PV Systems.....	12
2.3.3.3 Disadvantages Of PV Systems.....	13
2.4 Wind Energy.....	13
2.4.1 Historical Development Of Wind Power.....	13
2.4.2 How Is Wind Generated?	16
2.4.3 Types Of Wind Turbines.....	18
2.4.3.1 Horizontal Axis Wind Turbines (HAWTS).....	18
2.4.3.2 Vertical-Axis Wind Turbines (VAWTS)	23
2.4.4 Wind Speeds In Zambia	23
2.4.4.1 Variation Of Wind Speeds With Height Above Ground.....	24
2.4.5 Airfoil Design.....	26
2.4.5.1 NACA Classified Airfoils.....	28

2.4.5.2 NREL Airfoil Families.....	31
2.4.5.3 Airfoil Materials.....	33
2.4.6 Advantages Of Wind Energy.....	34
2.4.7 Disadvantages Of Wind Energy.....	34
2.5 Generator Types In Wind Turbines.....	34
2.6 Energy Storage.....	37
2.6.1 The Battery	37
2.7 Hybrid Systems	39
2.8 Power Electronic Converters (PEC).....	41

CHAPTER 3: METHODOLOGY

3.1 Introduction.....	44
3.2 Power needs assessment.....	44
3.3 Resource Assessment.....	44
3.4 Simulation of the Hybrid System.....	45
3.5 Design and Manufacture of the Hybrid System.....	45
3.6 Testing of the Hybrid System.....	45

CHAPTER 4: DESIGN OF THE HYBRID SYSTEM

4.1 Introduction.....	47
4.2 Description Of The Hybrid System.....	47
4.3 Wind Turbine Generator.....	49
4.3.1 The Rotor Blades.....	50
4.3.2 The Generator.....	55
4.3.3 The Turbine Body And Mounting.....	56
4.4 Setting Up The PV Panel for Power Generation.....	59
4.5 Outline of All components and Technical Specifications.....	59

CHAPTER 5: MANUFACTURING AND ASSEMBLY OF HYBRID SYSTEM

5.1 Introduction.....	62
5.2 Manufacturing Of The Wind Turbine System.....	62
5.3 Manufacture Of Other Components Of The Hybrid System.....	69

CHAPTER 6: COST OF THE HYBRID SYSTEM

6.1 Introduction.....	68
6.2 Costs And Simulation Of System Design Using Homer 2 Version 2.8.....	68

CHAPTER 7: TESTING OF THE HYBRID GENERATOR

7.1 Introduction	72
7.2 Testing of the Solar Component of the Hybrid System.....	72
7.3 Testing of the Wind Component of the Hybrid System	72
7.4 Testing of the Battery Component of the Hybrid System	72
7.5 Testing of the full Hybrid System	74

CHAPTER 8: RESULTS AND DISCUSSION

8.1 Introduction.....	76
8.2 Results.....	76
8.2.1 Solar PV component of the hybrid generator test results.....	76
8.2.2 Wind turbine component of the hybrid generator test results.....	76
8.2.3 Energy storage component of the hybrid test results	76
8.2.4 Full hybrid system test results.....	77
8.2.5 Simulation results.....	79
8.3 Discussion.....	82

CHAPTER 9: CONCLUSIONS AND RECOMMENDATIONS

9.1 Conclusions.....	84
9.1.1 Introduction	84
9.1.2 The Solar PV Generator.....	84
9.1.3 The Wind Turbine Generator.....	85
9.1.4 The Battery as Energy Storage.....	85
9.1.5 The Electronic Control System.....	85
9.1.6 The Hybrid System.....	85
9.2 Recommendations.....	86
References.....	87

APPENDICES

Appendix 1: Drawings.....	90
<i>Drawing 1: The blades</i>	90
<i>Drawing 2: Blade Mounting Hub</i>	91
<i>Drawing 3: Motor Bracket</i>	92
<i>Drawing 4: Blade Hub Assembly</i>	93
<i>Drawing 5: Bearing Hub</i>	94
<i>Drawing 6: Tail piece</i>	95
Appendix 2: Photo Gallery.....	96
<i>Figure A2.1: The Wind Turbine</i>	97
<i>Figure A2.2: The Solar Panel, Converters and Battery</i>	98
<i>Figure A2.3: The Hybrid Being Mounted At the School Of Engineering</i>	99
<i>Figure A2.4: The Hybrid in Action at the School Of Engineering</i>	100

LIST OF FIGURES

<i>1.1 Average Wind Speeds In Zambia</i>	2
<i>1.2 Average Solar Insolation For Zambia</i>	3
<i>2.1 An illustration of renewable energy sources</i>	6
<i>2.2 The Basic Structure of A Generic Silicon PV Cell</i>	8
<i>2.3 Basic P-N Junction</i>	9
<i>2.4 A Basic PV System Design for A Rural Household</i>	11
<i>2.5 The Installed Wind Capacity in The World</i>	14
<i>2.6 The New Installed Capacity By Year</i>	14
<i>2.7 The Total Wind Capacity for Some of The Countries</i>	15
<i>2.8 Total Installed Capacity Of Offshore Wind Power</i>	15
<i>2.9 Atmospheric Circulation of Air</i>	16
<i>2.10 Cylinder of Air in Front of the Rotor</i>	17
<i>2.11 Wind Turbine Types</i>	19
<i>2.12 Parts of a Horizontal Axis Wind Turbine (HAWT)</i>	21
<i>2.13 Principle of Wind Turbine Aerodynamic Lift</i>	22
<i>2.14 Airfoil Design Parameters</i>	26
<i>2.15 The Angle of Attack and the Chord Line on an Airfoil</i>	27
<i>2.16 A Cambered and an Un-Cambered Airfoil</i>	28
<i>2.17 NACA 2412 Airfoil Charts</i>	29
<i>2.18 NACA 2412 Airfoil Charts</i>	30
<i>2.19 Generic NACA 2412 Airfoil</i>	31
<i>2.20 Conventional Induction Generators</i>	35
<i>2.21 Wound-Rotor Induction Generator</i>	35
<i>2.22 Doubly-Fed Induction Generator</i>	35
<i>2.23 Full Converter Interface Generator</i>	36
<i>2.24 Characteristics of Different Types of Batteries</i>	38
<i>2.25 Illustration of Hybrid System Components</i>	40
<i>2.26 Parallel-Connected Power Converters in a Stand-Alone AC System</i>	41
<i>2.27 Power Converter Connected In Parallel With The Utility Mains</i>	42
<i>2.28 Parallel-Connected Power Converters In A Stand-Alone DC System</i>	42
<i>2.29 Paralleled-Connected Power Converters With A Common DC Grid</i>	43
<i>4.1 Block Diagram of the Hybrid System</i>	48
<i>4.2 NACA 2412 Blade Shape</i>	51
<i>4.3 Velocity Vector Diagram</i>	54
<i>4.4 Schematic Drawing Of The Victory Permanent Magnet Generator</i>	57
<i>4.5 Wind Turbine System Assembly</i>	58
<i>5.1 Illustration Of 8 Inch Pipe For The Turbine Blades</i>	63

5.2 Cutting Of The Blades.....	64
6.1 Cash Flow Summary Of The Hybrid System.....	69
6.2 Cash Flow Simulation.....	70
7.1 Connection Of The PV Panel.....	73
7.2 Connection Of The Wind System.....	74
7.3 Connection Of Hybrid Generator.....	75
8.1 Voltage characteristics of components of the hybrid generator.....	78
8.2 PV output distribution throughout the year.....	79
8.3 Wind Turbine Output Distribution Throughout The Year.....	80
8.4 Battery State Of Charge Throughout The Year.....	80
8.5 Converter Output Throughout The Year.....	80
8.6 Simulation Results For The Hybrid System For 1 Year.....	81

LIST OF TABLES

2.1 Average wind speeds in Zambia.....	23
2.2 Terrain characteristics and friction coefficients.....	25
2.3 Terrain characteristics and roughness heights.....	26
2.4 Estimated annual energy improvements from NREL airfoil families.....	32
2.5 NREL Airfoil families.....	33
2.6 Summary of airfoil materials and their properties.....	33
2.7 Characteristics of different types of batteries.....	38
2.8 Summary comparison of the specific energy.....	39
2.9 A summary on the life and cost aspects of the rechargeable batteries.....	39
4.1 Energy consumption of some common household equipment.....	49
4.2 Power demand of various components and the peak demand of the system.....	49
4.3 Classification of wind turbines.....	50
4.4 Parameters of the adapted NACA 2412 airfoil generated using airfoil tools.....	52
4.5 Characteristics of the generator at different speeds.....	56
4.6 Summary of components, notes and specifications.....	60
5.1 NACA 2412 specification data.....	64
5.2 Manufacture of components.....	65
6.1 Hybrid system architecture.....	68
6.2 Cost summary report.....	68
6.3 Net present costs.....	69
6.4 Annualized costs.....	70
6.5 Actual costs of all components.....	71
8.1 Electrical contribution of each power source in percentages.....	79
8.2 Possible emissions in kilograms per year of each pollutant or greenhouse gas (GHG).....	81

LIST OF SYMBOLS

E_λ	Emissive power per unit area of a blackbody (W/m ² μm)
λ	Wavelength (μm)
T	Temperature of the body
T	Tilt Angle of the Sun
E	Total blackbody emission rate (W)
σ	Stefan Boltzmann constant
A	Surface area
m	Mass
v	Speed
ρ	Density of air
A	Cross-section area
H_0	Reference height
V_0	Reference wind speed at H_0
a	Friction coefficient
Z	roughness length
c_m	The pitching moment coefficient
m	pitching moment
C	Chord
W	Maximum Camber as Percent of the Chord Length
X	Location of the maximum Chord Length
Y	Maximum thickness in percent of the chord length
Z	Maximum thickness in percent of the chord length
C_L	Lift coefficient

F_LLift Force
 F_DDrag Force
 C_DDrag coefficient
 nSpeed of rotation
 β_NAltitude Angle at Solar Noon
 LLatitude angle
 δSolar declination angle

LIST OF EQUATIONS

2.1 Planck's law.....	7
2.2 Stefan Boltzmann law.....	7
2.3 Wien's displacement rule.....	7
2.4 Altitude Angle at Solar Noon.....	12
2.5 Solar Declination Angle.....	12
2.6 Tilt Angle.....	12
2.7 kinetic energy of the wind.....	17
2.8 Energy per second of the wind.....	17
2.9 Mass Flow rate.....	17
2.10 Energy per second.....	17
2.11 Power in the wind.....	18
2.12 Power Law.....	25
2.13 Alternative Power Law.....	25
2.14 Pitching Moment coefficient.....	28
2.15 Prandtl-Glauert Correction factor.....	30
4.1 Power in the wind.....	52
4.2 Power in the wind at BETZ limit.....	52
4.3 Power in the wind at mechanical efficiency.....	52
4.4 Speed of rotation.....	53
4.5 Chord length.....	53
4.6 Angle between the relative velocity and its vertical component.....	53
4.7 Relative velocity of the wind turbine.....	54
4.8 The lift force.....	54
4.9 The drag force.....	55
4.10 The Torque.....	55
4.11 Power of the wind turbine.....	55

ACRONYMS AND ABBREVIATIONS

1. HAWT.....Horizontal-Axis Wind Turbines
2. VAWTs.....Vertical Axis Wind Turbines
3. NREL.....National Renewable Energy Laboratory
4. SERI.....Solar Energy Research Institute
5. PECs.....Power Electronic Converters
6. TSR.....Tip Speed Ratio
7. NACA.....National Advisory Committee on Airfoils
8. WCED.....World Commission on Environment and Development
9. Mtoe.....Megatons Of Oil Equivalent
10. AFPMG.....Axial Flux Permanent Magnet Generator

CHAPTER 1: INTRODUCTION

1.1 Introduction

In the last two decades, increasing global demand for energy, the environmental threats associated energy production from fossil fuels and the fact that fossil fuels are finite in nature have led to an exponential growth of energy production from renewable sources. These sources of renewable energy available worldwide include;

1. Solar energy
2. Wind energy
3. Sea wave energy
4. Biomass
5. Hydropower
6. Geothermal energy

Two forms of renewable energy, that is solar and wind are available almost everywhere on planet earth and hence this research work will concentrate on wind and solar as the renewable energy sources of interest

Wind energy is caused by solar heating of the atmosphere which causes unequal expansion in different regions of the earth leading to density variations. The density variations lead to convection currents and movements of large masses of air, the amount of heat received by each region of the earth depends on the angle of the regions diametric plane to the sun, other conditions such as the cloud cover and pollutants in the air above play an important role (Mwenda, 2014).

Wind carries enormous amounts of energy and it has been used in many countries for many decades as an energy source, the penetration of wind energy use in Zambia is still very low and the most common type of use is mainly for water pumping. Literature has shown that wind turbines require an effective wind speed of about 3m/s to start generating useful power, off course there are other factors involved such as the torque of the generator and the size of the blades, these factors may well affect the speed of rotation and this was considered in other chapters. Figure 1.1 shows the average wind characteristics that are experienced in Zambia, as can be seen the wind regime is divided into three averages that is; the low, the medium and high averages, all these averages are important as they determine when the wind turbine will begin to rotate, when it will begin to generate useful power and when it may not work (Mwenda, 2014).

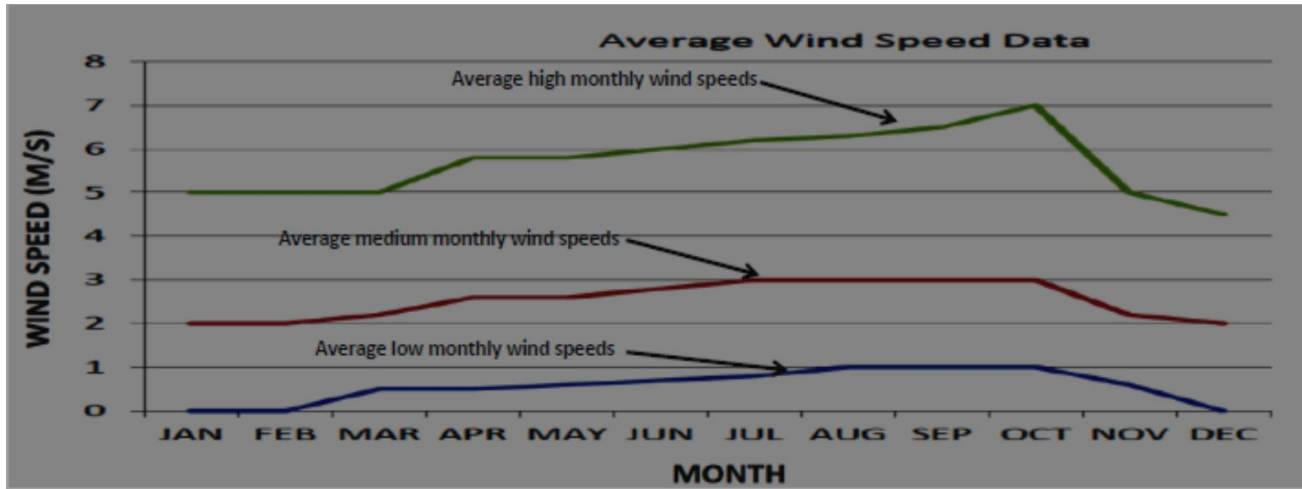

Figure 1.1: The figure shows the low average, medium average and high average wind speeds experienced in Zambia (Meteorological Department of Zambia, 2014).

The source of solar insolation is anyone’s guess, the sun. The sun put simply is that gigantic, 1.4 million kilometer diameter, thermonuclear furnace fusing hydrogen atoms into helium. The resulting loss of mass upon fusion is converted into about 3.8×10^{20} MW of electromagnetic energy that radiates outward from the surface into space (Masters, 2004).

Solar energy can be utilized directly as concentrated solar power (CSP) or can be converted into electrical energy by photovoltaic technology or PV, for the purposes of this research we will concentrate on PV. A photovoltaic (PV) is an electronic material or device that converts light energy (photons) into electronic (or electrical) voltage and current. The history of PVs began in 1839 when a 19 year old French physicist *Edmund Becquerel* caused a voltage to appear when he illuminated a metal electrode placed in a weak electrolyte solution, 40 years later *Adams and Day* were first to study the PV Effect in solids and managed to build PV cells selenium (Se). The PV cells were one to two percent efficient. Se PV cells were quickly adopted for use as photometric light meters in the then emerging photography industry and which use continues even today. In 1904 *Albert Einstein* published a theoretical explanation of the PV Effect which led to a Nobel Prize in 1923 (Masters, 2004).

About the same time as Einstein, a Polish scientist *Jan Czochralski* began growing perfect crystals of silicon (Si), a development that is a cornerstone of electronic and PV devices. By the 1940s the *Czochralski* Process began to be used to make first generation single crystal silicon PVs and which technique continues to dominate the PV industry up to date. In the 1950s there were several attempts to commercialize PVs but their cost of production was too high. However, between 1980 and 1996, the capital cost of PV modules per watt of power capacity had declined from more than \$20 per watt to less than \$5 per watt this reduction sparked tremendous growth of the industry. Figure 1.2 shows the average insolation for the country from the figure it is seen that the solar insolation is on average around 5KWh/m²/day this is more than enough solar insolation for domestic power generation. (Masters, 2004).

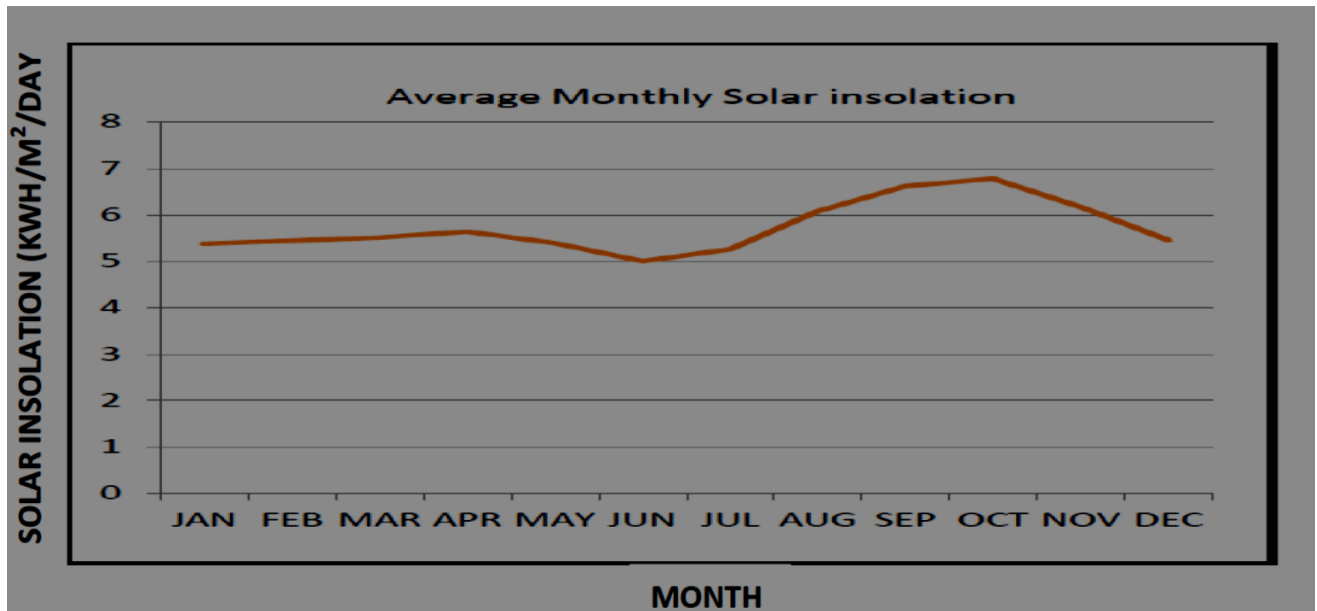

Figure 1.2: The figure shows the average solar insolation experienced in Zambia (Meteorological Department of Zambia, 2014).

Hybrid systems combine two or more modes of electricity generation together, usually using renewable technologies such as solar photovoltaic (PV) and wind turbines. Hybrid systems provide a high level of energy security through the mix of generation methods and often will incorporate a storage system (battery, fuel cell) or small fossil fueled generator to ensure maximum supply reliability and security. Off grid renewable energy hybrid technologies satisfy energy demand directly and this avoids the need for long distribution infrastructures.

In the past two decades hybrid technology has developed and assumed a pivotal role as a renewable energy source. The benefits associated with hybrid technology for autonomous power production are almost unrivaled. Many rural and urban households around the world are utilizing hybrid systems. Isolated islands and places far from electric grids are trying to adopt this kind of technology because of the benefits which are associated with it in comparison with single renewable energy systems (Mwanza, 2014).

1.2 Statement of the Problem

The driving factor for the selection of this Research and Development (R & D) work on wind and Solar energy hybrid application was the need to empower rural communities with communication technology namely cellular phones which are now widely used in Zambia. A major constraint to the use of cellular phones in the rural areas is the poor supply or the non-availability of reliable electricity supply for recharging the cell phones.

Despite these rural areas constituting more than forty percent of the Zambian population, such population has little or no access to electricity from the national grid system, this is so because of the long distances of these areas from the grid and also low economic activity in these areas, hence the need for utilization of the locally available energy resources in these rural areas.

Literature has shown that most of the rural areas in Zambia have abundant wind and solar resource that can be successfully utilized for electrical power generation. With the global issues of climate change and energy sustainability high on the national agenda, this need for energy in rural areas must be driven by sustainable energy generation systems. Wind and Solar energy can, therefore be used as an energy source for not only pumping water in some remote parts of the country but also as a source for electric power generation for charging cellular phones, lighting houses, cooking and other uses (Mwenda, 2014).

1.3 Objectives

The main objective of this research project was to design, manufacture and test a 3-blade Wind Turbine/Solar PV hybrid generator for powering an off-grid site. The specific objectives of the research were as outlined below.

1. To Analyze weather data in relation to wind speeds and solar insolation in Zambia and this was used for the development of an optimal design of a Wind /Solar Hybrid generator for charging cell phones;
2. To design and manufacture a prototype Wind/Solar based charger system suitable for charging batteries that were to be used to power an off-grid site.
3. To design an electronic converter system linking wind and solar power for the Hybrid system;
4. To size and design a suitable energy storage system for the generator;
5. To conduct prototype tests on the wind solar hybrid system so as to analyze and optimize the design.

CHAPTER 2: LITERATURE REVIEW

2.1 Introduction

With increasing demand for energy and global warming, many countries are looking at environment-friendly energy solutions to preserve the earth for the future generations. Other than hydro power, many such energy sources like wind and photovoltaic energy hold the most potential to meet our energy demands. While some others like fuel cells are in their advanced developmental stage. The world's fastest growing energy resources, a clean and effective modern technology that provides a hope for a future based on sustainable, pollution free technology. Today's photovoltaic and wind turbines are state-of-the-art and very quick to install. These generation systems have been attracted greatly all over the world. The integration of renewable energy sources and energy-storage systems has been one of the new trends in power-electronic technology.

This part of the report reviews various literatures on energy trends, wind and solar energy systems; it also looks at the associated energy storage and conversion systems. The chapter looks at solar systems, their development, function and the calculations involved in the design of the systems. It also looks at the aspects involved in the development and use of wind turbine systems for the generation of electricity, furthermore the combination of wind and solar is also reviewed. The design aspects of the combination or hybrid system is also studied and outlined in this chapter.

2.2 Renewable Energy Sources

Renewable energy sources are mostly independent and naturally occurring in nature. Renewable energy sources have their basic origin from the sun. The useful radiation from the sun that reaches the Earth's surface, apart from being vital to human survival, provides our planet with energy in various forms. The uneven heating and cooling of the earth's surface creates the wind, it evaporates large quantities of the earth's water and it maintains the natural cycle of the water, creating lakes and rivers which can then be used for hydropower generation. Solar Radiation can also be directly absorbed by special materials called Photovoltaic's or PV and this solar radiation also drives the photosynthesis phenomenon and thus creates bioenergy.

Renewable energy sources can be harnessed safely and are unlimited if utilized sustainably, in addition these renewable energies are said to have closed carbon cycles and hence emit zero net carbon dioxide which makes them ecofriendly. With few exceptions most renewable energy sources can be found locally and so cannot be exploited or manipulated politically. Furthermore renewable sources can add diversity to energy supply and create options for distributed generation. Although renewable energy sources, in the current economic and technological era may not be able to give all the solutions to our energy needs today but with future efficient energy systems and combination of these renewables as a hybrid system, a lot can be achieved. Figure 2.4 illustrates the renewable energy sources (Chisale, 2014).

2.3 Solar Energy

2.3.1 The Solar Resource

To successfully analyze and design solar systems, the question of how much sunlight is available must be answered. To do this a set of equations is used to predict where the sun is in the sky at any time of day for any location on the planet earth, as well as the solar intensity on a relatively clear day. Average daily insolation figures can be obtained from values collected over long periods of time usually years under the combination of clear and cloudy conditions. Another set of equations can then be used to estimate the insolation on collector surfaces that are not flat on the ground or of different shape.

The source of the required insolation is the sun. The sun is a gigantic approximately 1.4 million kilometer diameter, thermonuclear furnace that produces solar energy by fusing hydrogen atoms into helium. The fusion process results in a net loss of mass that is converted into about 3.8×10^{20} MW of electromagnetic energy. The electromagnetic energy radiates from the surface of the sun towards the earth through space (Masters, 2004).

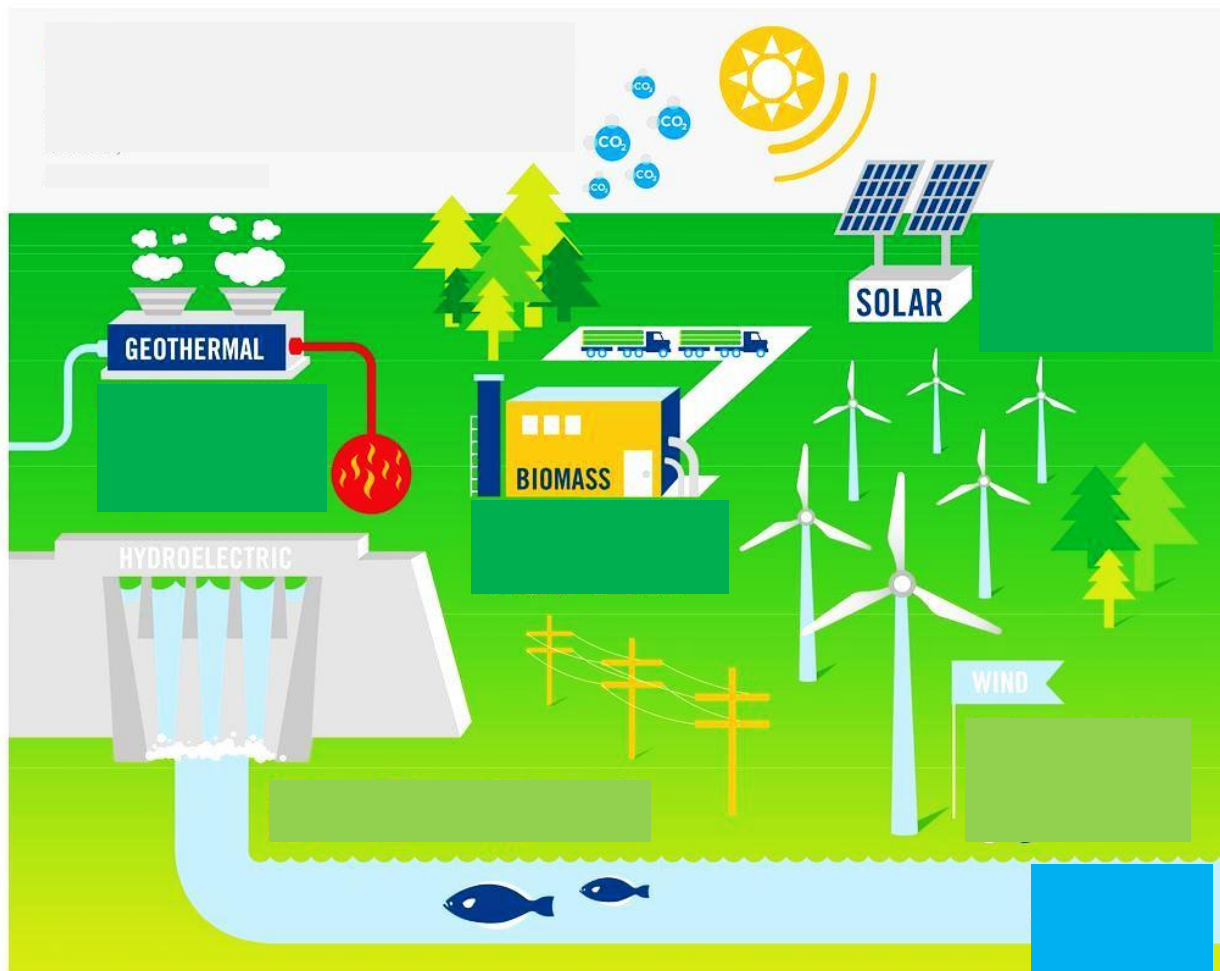

Figure 2.1: An illustration of renewable energy sources (Chisale, 2015).

Every object at a given temperature emits radiant energy and the amount of that radiant energy is a function of its temperature. The emitted radiation of any object can be compared to a theoretical abstraction called a *blackbody*. A blackbody is defined as a perfect emitter as well as a perfect absorber. As a perfect emitter, it radiates more energy per unit of surface area than any real object at the same temperature. As a perfect absorber, it absorbs all radiation that impinges upon it, none is reflected and none is transmitted through it (Masters, 2004).

The relationship between the emitted wavelength and the temperature of a blackbody is described by *Planck's law* below (Masters, 2004).

$$E_{\lambda} = \frac{3.74 \times 10^8}{\lambda^5 \left[\exp \left(\frac{14,400}{\lambda T} \right) - 1 \right]}$$

Equation 2.1

Where: E_{λ} = emissive power per unit area of a blackbody (W/m²μm)

λ = is the wavelength (μm)

T = the temperature of the body

The total emissive power of a blackbody is given by *Stefan Boltzmann law* as below.

$$E = A\sigma T^4$$

Equation 2.2

Where: E = is the total blackbody emission rate (W)

σ = Stefan Boltzmann constant

A = surface area

Wien's displacement rule which predicts the wavelength at which the spectrum reaches its maximum point is given below in equation 2.3.

$$\lambda_{\max} (\mu\text{m}) = \frac{2898}{T (\text{K})}$$

Equation 2.3

2.3.2 Photovoltaic Technology

The photovoltaic effect in simple terms is the generation of electricity from light or solar radiation. The term *photovoltaic* is a compound word and comes from the Greek word for light *photos* and the word *volt* which is the unit of electromotive power.

The photovoltaic technology experienced rapid development during the second half of the twentieth century, even though the photovoltaic effect had been observed by *Edmond Becquerel* in 1839. In 1877 the first report of PV effect was published by two Cambridge scientists *Adams* and *Day* and in 1883 *Charles Fritts* built a selenium solar cell similar to contemporary solar silicon cells with an efficiency of less than one percent. In 1954 *Chapin, Fuller* and *Pearson* announced the first manufacture of a solar element with a p-n junction with a low efficiency of about six percent (Masters, 2004).

The initial commercial manufactures were very costly, at around US\$1000/Wp in 1956, with relatively small efficiency of about 5-10 percent and they were made of crystalline materials, mainly by crystal silicon (c-Si). Nowadays the efficiency of the best crystalline silicon cells has reached around 24 percent for photovoltaic cells used in aerospace technology and about 14-16 percent overall efficiency for those used for industrial and domestic use. The cost is around US\$5/WP if they are purchased in mass (Masters, 2004).

The structure of a basic photovoltaic cells is quite simple, they constitute of about six different layers of materials as shown in Figure 2.5 below. The firstly layer is a cover glass surface which helps increase photon absorption and protects the cell from the atmospheric elements, the next layer is usually an antireflective coating which reduces the reflection losses from the photons to less than five percent. The next layer is the contact grid which helps to minimize the distance which the photons have to travel in order to reach the semiconductors. The next two thin layers are the semiconductors p and n junctions. The final layer is the back contact which facilitates better conduction (Witherden, 2003).

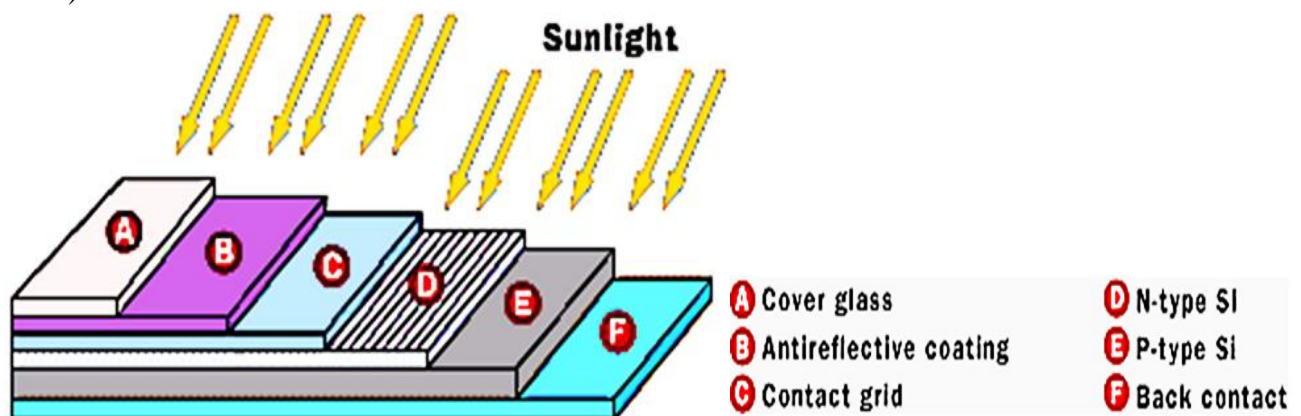

Figure 2.2: The figure illustrates the basic structure of a generic silicon PV cell (Witherden, 2003).

A typical photovoltaic cell consists of two semiconductor types that is the p-type and the n-type which may both be made of crystalline silicon. The n-type semiconductor is created when some of the atoms of the crystalline silicon structure are replaced by atoms of another material that is of higher valence like phosphorus. The n-type semiconductor is created which has a surplus of free electrons in its valence band. On the other hand a p-type semiconductor is created when some of the atoms of the crystalline silicon are replaced by atoms with lower valence like boron and the result is the creation of another material with a deficit of free electrons and is known as a p-type semiconductor, the missing electrons are called holes. The basic concept of a p-n junction is shown below (Masters, 2004).

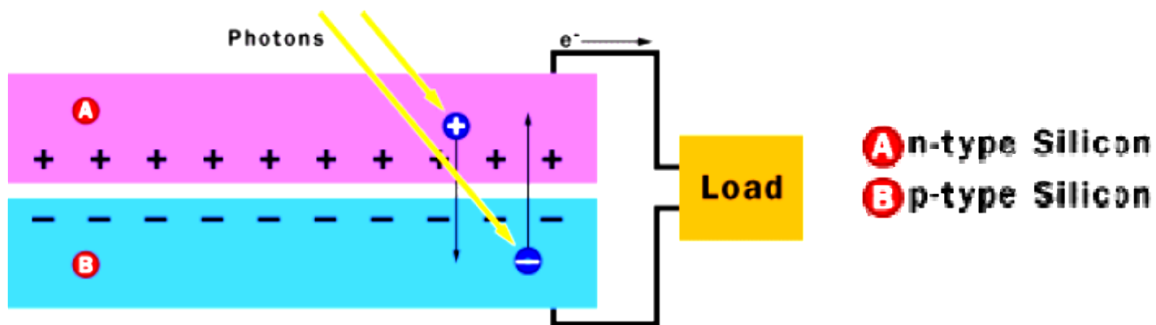

Figure 2.3: The figure illustrates the basic p-n junction (Witherden, 2003).

When the p and n type semiconductors are connected the result is a p-n junction, an electric field is then set up in the region creating what is called a depletion region or layer. As shown in Figure 2.6 above electrons move by diffusion from one semiconductor to the other.

The photovoltaic effect is initiated by the sun's light beams. When the photovoltaic cell becomes exposed to the light beam which consists of photons, the electrons are stimulated and they gain enough energy to move rapidly. The electrons jump into the conduction band leaving behind holes in the valence band and this phenomenon allows for electricity generation (Banda, 2014).

The material that is used widely in the industry for the production of photovoltaic cells is silicon. Impure Silicon exists as common sand in the form of silicon dioxide (SiO_2). Photovoltaic cells can be classified into five different categories, depending on the structure of the basic material from which they are made and the particular way of their preparation (Zulu, 2014). The types include:-

- Single crystal (dominant type)
- Multi-crystalline (1 mm – 10 cm)
- Polycrystalline (1 μm – 1 mm) e.g. CdTe, CuInSe₂
- Microcrystalline (< 1 μm)
- Amorphous (no single crystal region) e.g. a-Si

They can also be classified according to the thickness of the semiconductor as follows:-

- Thick (conventional): 200 – 500 μm [80 % of PVs]
- Thin film: 1 – 10 μm [20 % of PVs]

2.3.3 PV Systems

A basic PV system is illustrated in Figure 2.7 below; apart from the PV cells a complete system includes an energy storage feature mostly electrochemical batteries, charge controllers and inverters. Depending on the type of system design a standby generator may also be included.

The batteries are used for the storage of the energy which is produced by PV cells. The batteries provide energy in intervals of low PV generation usually during cloudy or rainy days and during night time when there is no generation at all. There are many types of batteries but the most common types batteries are the deep-cycle lead acid batteries. The six major types of batteries as listed below (Zulu, 2014).

- 1 Lead-acid (Pb-acid)
- 2 Nickel-Cadmium (NiCd)
- 3 Nickel-metal hydride (NiMH)
- 4 Lithium-ion (Li-ion)
- 5 Lithium-polymer (Li-poly)
- 6 Zinc-air

SOLAR HOME LIGHTING SYSTEM

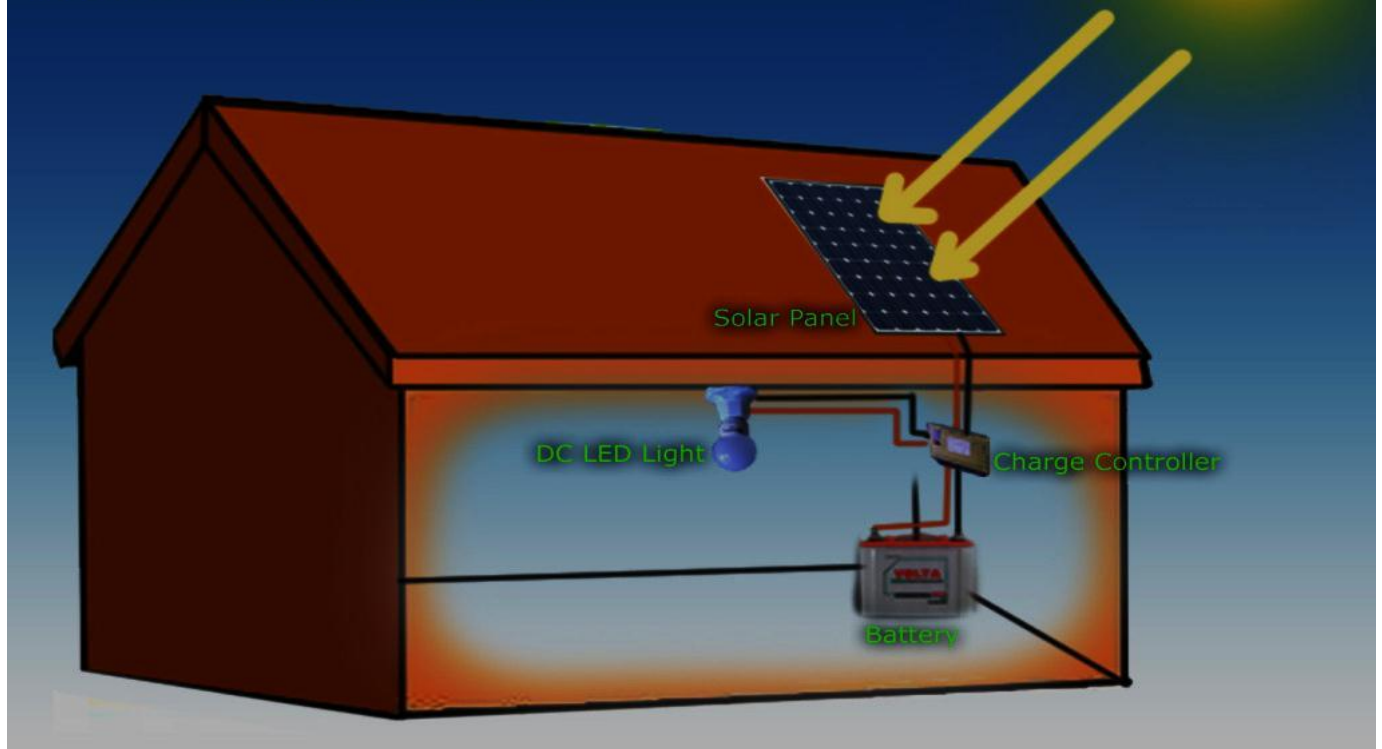

Figure 2.4: The figure illustrates a basic PV system design for a rural household (Suryodaya , 2008).

The other types of energy storage are also listed below.

- 1) The Flywheel
- 2) Compressed air
- 3) Superconducting coil
- 4) Pumped water storage

Batteries are almost always used with a charge controller; this is a vital device that ensures correct charging of the battery and also ensures a user enjoys the full battery life. DC loads can be connected directly to the battery while for the AC loads there is need for an inverter. The inverter is a device that converts direct current (DC) into alternating current (AC). The conversion to AC is essential since most loads are AC in nature. The efficiency of the inverters is quite high and varies between 93 and 96 percent (Zulu, 2014).

2.3.3.1 Setting up a PV System

To successfully setup the solar panel for solar power generation a rule of thumb can be used for the first step and it states that if you're in the:-

- Northern hemisphere: face the collector South
- Southern hemisphere: face the collector North

The solar collector can then be tilted at an angle equal to the local latitude; this method can be used for good annual performance.

To find the optimum tilt angle however a few calculations need to be done first we note that the altitude angle at solar noon is given by the equation:

$$\beta_N = 90^\circ - L + \delta, \quad \text{Equation 2.4}$$

Where: δ is the solar declination and given by the equation;

$$\delta = 23.45 \sin\left(\frac{360}{365}(n - 81)\right), \quad \text{Equation 2.5}$$

L is the latitude and n is the day number

For a collector to collect the optimum amount of solar energy we must first face the collector north and the raise it to a tilt angle T of:

$$T = \beta_N - 90, \quad \text{Equation 2.6}$$

It must be noted though that this angle will be changing depend on the day number; a tilt angle equal to the latitude is acceptable for practical purposes (Zulu, 2014).

2.3.3.2 Advantages of PV Systems

Photovoltaic modules can easily penetrate in isolated areas since the electrical power they produce comes from an independent and reliable source, the sun. Some of the advantages of PV systems are listed below (Zulu, 2014).

- 1) Low maintenance cost.
- 2) Very minimal operation cost.
- 3) A long life cycle; they can provide power up to 20-25 years.
- 4) There is very little variability in their efficiency and energy storage can normalize any fluctuations.

- 5) No noise during their operation.
- 6) Protection of the environment from pollution and climate changes.
- 7) Solar energy can be made available almost anywhere there is sunlight
- 8) The cost of installation is fast reducing and is expected to continue reducing in the next coming years.

2.3.3.3 Disadvantages of PV Systems

The disadvantages of PV systems include (Zulu, 2014).

- 1) As with all renewable energy sources, solar energy has intermittency issues.
- 2) The intermittency greatly reduces the reliability of the solar energy.
- 3) A lot of additional equipment such as inverters and charge controllers are required to use the system.
- 4) A form of energy storage is required because of the intermittent nature of solar power and this raise the investment costs.
- 5) The efficiency of the PV panels is very low (14-25 percent) as compared to other renewables.
- 6) The solar panels are fragile and can be damaged relatively easily.

2.4 Wind Energy

2.4.1 Historical Development of Wind Power

Wind has been used as a source of energy for thousands of years; it was mainly used for tasks such as propelling of huge sailing ships, mechanical grinding of grain, pumping water and powering of old types of factory machinery. One of the world's first wind turbines used to generate electricity was built by a Dane, *Poul la Cour*, in 1891. In the United States the first wind-electric systems were built in the late 1890s; by the 1930s and 1940s, hundreds of thousands of small-capacity, wind electric systems were in use in rural areas not yet served by the electricity grid. In 1941 one of the largest wind-powered systems ever built went into operation at Grandpa's Knob in Vermont. Designed to produce 1250 kW from a 175-ft-diameter, two-bladed prop, the unit had withstood winds as high as 115 miles per hour before it catastrophically failed in 1945 in a modest 25-mph wind, one of its 8-ton blades broke loose and was hurled 750 feet away (Masters, 2004).

It is estimated that wind energy is a 50 billion Euro business in terms of revenue and it employs about 550,000 people around the world. Figure 2.8 shows the total installed capacity of wind.

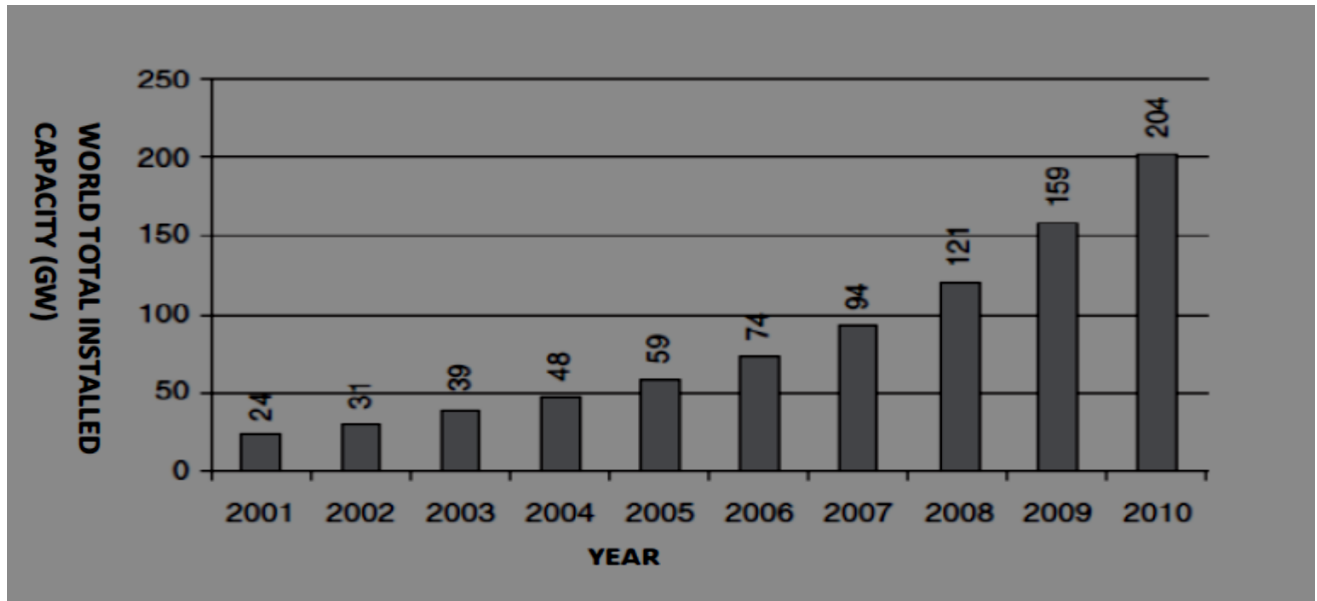

Figure 2.5: The figure shows the installed wind capacity in the world from 2001-2009, 2010 capacity was forecasted (International Energy Agency, 2009).

In 2009 about 159.2 GW of wind capacity was online. Figure 2.9 shows the new installed capacity by year. The pace of growth of new installed capacity has been increasing; in fact, the world market for wind capacity grew almost 22 percent in 2004 and has steadily increased to almost 32 percent in 2009. Figure 2.10 illustrates the total wind capacity for some of the countries. The United States leads in wind capacity installations with 35.1 GW, followed by China and Germany at 26 and 25.7 GW, respectively. The UK leads in offshore installations, with a total capacity of 688 MW followed by Denmark at 663 MW as shown in *Figure 2.11* (International Energy Agency, 2009).

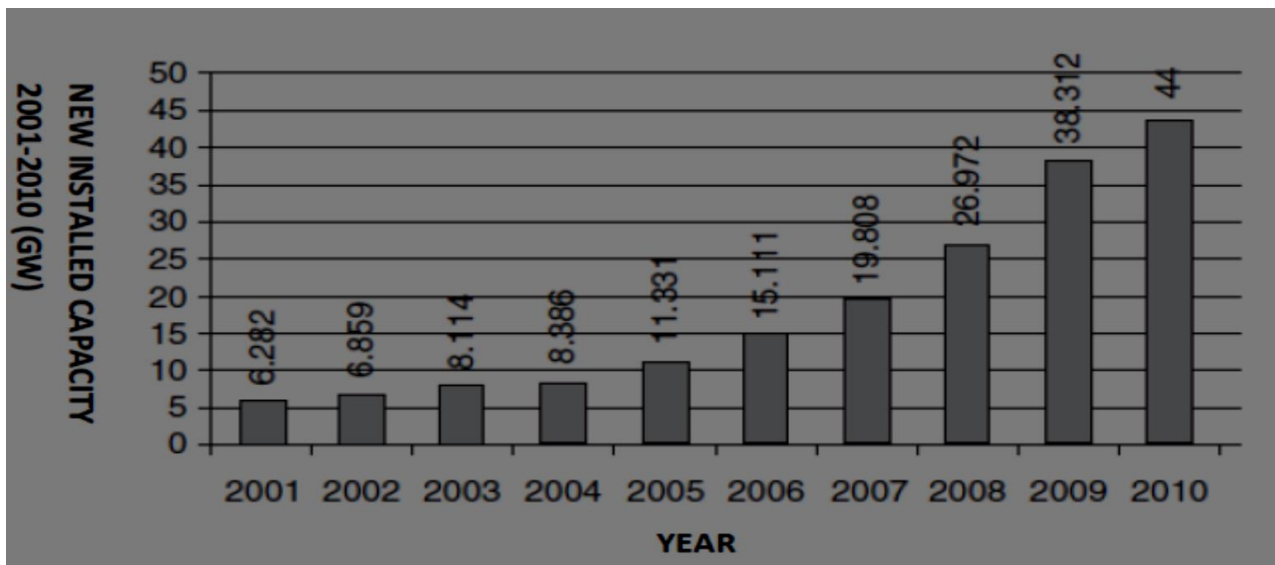

Figure 2.6: The figure shows the new installed capacity by year (International Energy Agency, 2009).

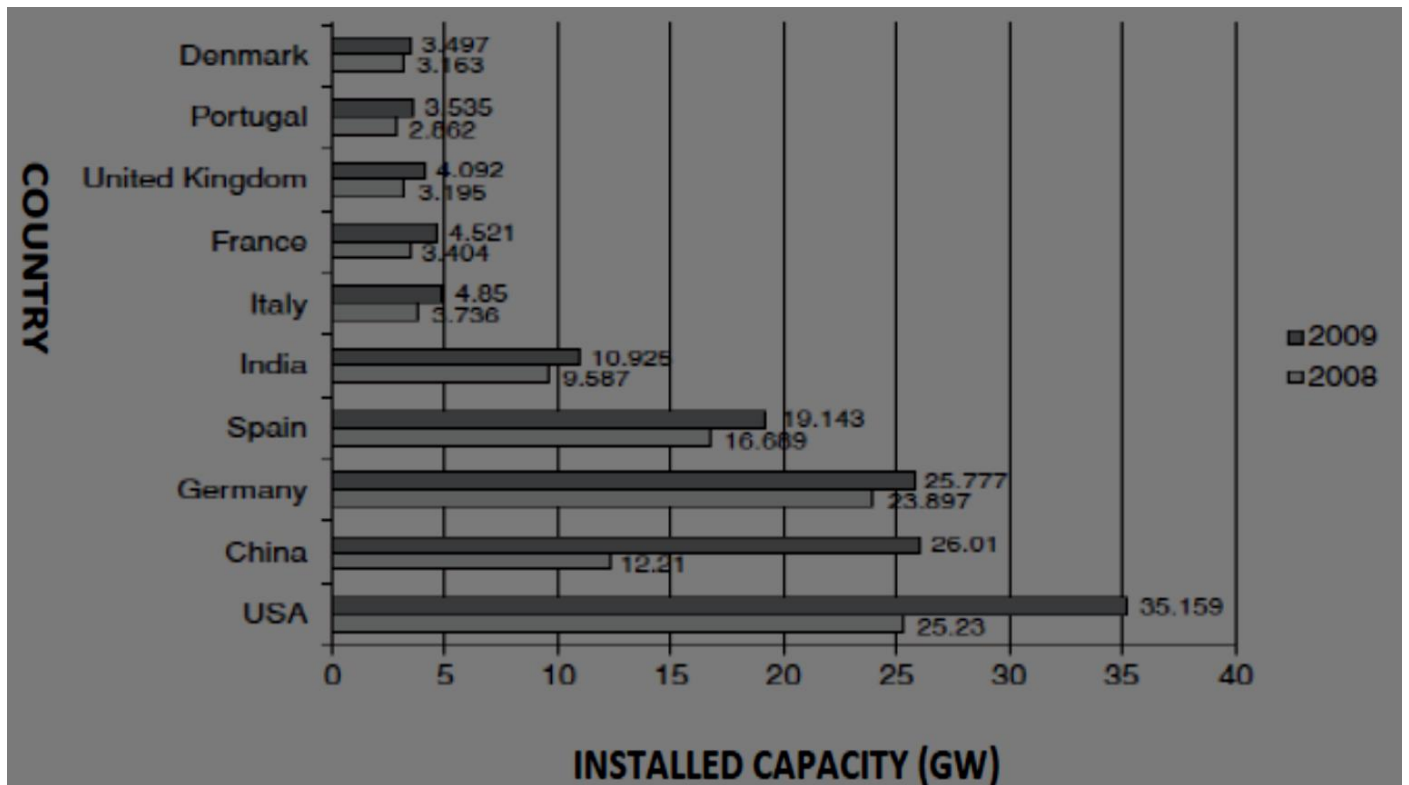

Figure 2.7: The figure shows the total wind capacity for some countries in the world (International Energy Agency, 2009).

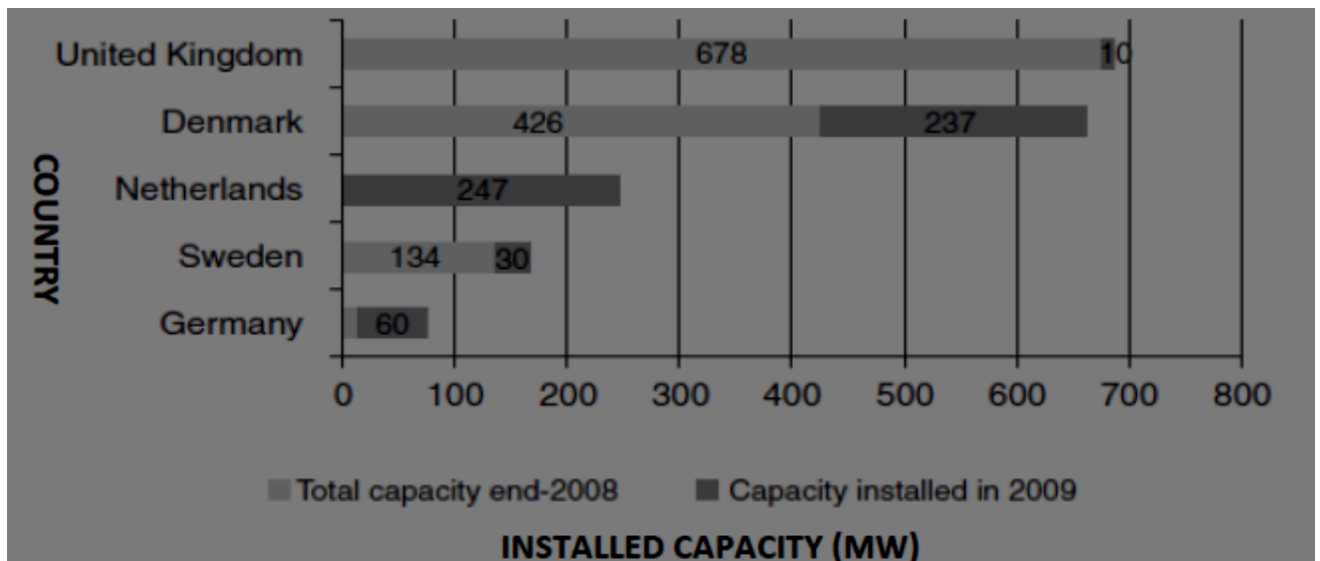

Figure 2.8: The figure shows the total installed capacity of offshore wind power (International Energy Agency, 2009).

2.4.2 Theoretical Analysis of Wind Power Generation?

Uneven heating of the surface of the earth creates wind. Solar energy absorbed by land or water is transferred to the atmosphere. A large amount of solar radiation is received at the tropics compared to the poles, which causes hot air to rise at the tropics and flow toward the poles. This flow occurs 10 to 15 km above the earth's surface. The Coriolis force causes the flow of hot air in the upper atmosphere to turn right. This flow does not continue beyond 30° latitude (Mwenda, 2014).

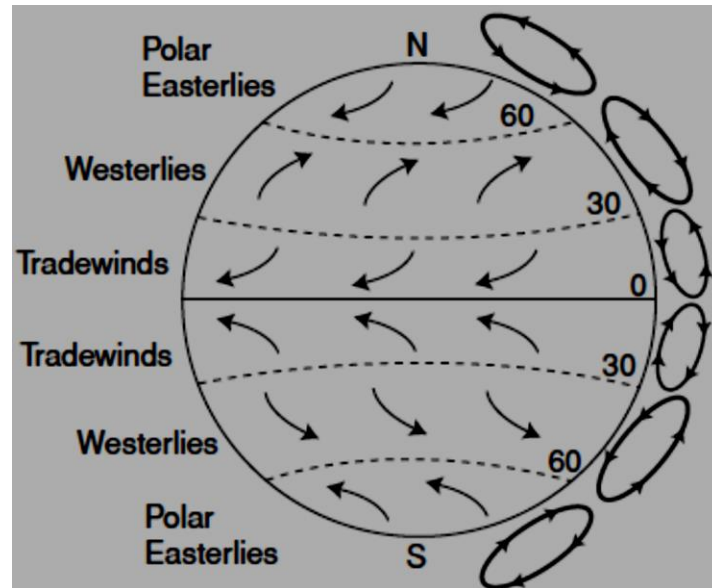

Figure 2.9: The figure shows the atmospheric circulation of air, the arrows between the latitude lines indicate the direction of surface winds. The closed circulation or convection shown on the right indicates the vertical flow of air (Masters, 2004).

This vertical motion of hot air causes low pressure at the tropics. Cold air from the higher latitudes flows toward the tropics; these are “surface” winds that are called trade winds. **Figure 2.12** illustrates the direction of prevailing wind because of solar radiation differences and Coriolis force in each 30° latitude band. This large-scale atmospheric circulation defines the global flow of air. The effect of this circulation is to redistribute the heat (Mwenda, 2014).

The totalities of the atmospheric mechanisms that play a role in wind are complex and include local effects. Some of the primary local effects are:

- 1) Landmass heats and cools faster than water body. This causes a sea breeze, which is wind from the sea to land during the day, with reverse flow during the night.
- 2) Orography and roughness. Orography is change in elevation of earth's surface; roughness is a measure of the friction on the surface of the earth. Changes in elevation can cause a mountain breeze.

Wind is typically generated from the kinetic energy of the wind, given as below;

$$E = \frac{1}{2}mv^2$$

Equation 2.7

Where: m is mass and v is speed; units of energy are $\text{kg m}^2/\text{s}^2 = \text{Joule}$.

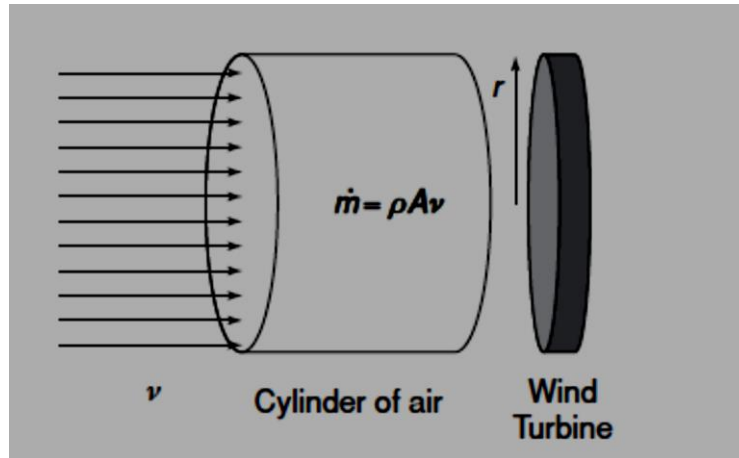

Figure 2.10: Cylinder of air in front of the rotor (Masters, 2004)

The mass (m) from which energy is extracted is the mass contained in the volume of air that will flow through the rotor. For a horizontal axis wind turbine (HAWT), the volume of air is cylindrical, as shown in *Figure 2.13* (Masters, 2004).

With air flow, it is convenient to think of mass in a cylinder of air of radius r . Since v m/s is the wind speed, the mass contained in cylinder of length v meters and radius r is the amount of mass that will pass through the rotor of turbine per second. It is, therefore, convenient to use mass per second (\dot{m}) in Equation 2.4.

$$\dot{E} = \frac{1}{2}\dot{m}v^2$$

$$\dot{m} = \rho A v$$

Equations 2.8 and 2.9

Where: ρ is air density, A is the cross-section area and \dot{m} is the amount of matter contained in a cylinder of air of length v . \dot{E} is energy per second, which is the same as power P .

$$\dot{E} = P = \frac{1}{2}\rho A v^3 = \frac{1}{2}\rho A v^3$$

Equation 2.10

For a HAWT, the area $A = \pi r^2$, where r is the radius of the rotor, therefore

$$P = \dot{E} = \frac{1}{2} \rho \pi r^2 v^3$$

Equation 2.11

However according to Betz law the maximum power that can be extracted from the wind, that is excluding design efficiencies in open flow is only about 59 percent of the available wind (Masters, 2004).

2.4.3 Types of Wind Turbines

The early wind turbines were used mostly to grind grain into flour and this is where the name windmill was derived.

Generally wind turbines can be classified in terms of the axis in which the shaft is oriented and they can be classified as horizontal axis wind turbines (HAWTs) or as vertical axis wind turbines (VAWTs). Examples of the turbines are shown in *Figure 2.14* (Mwenda 2014).

2.4.3.1 Horizontal Axis Wind Turbines (HAWTS)

Horizontal-axis wind turbines (HAWTs) have their main rotor shaft and electrical generator at the top of a tower and these are pointed into the wind. Small HAWTs are pointed by a simple wind vane, while large turbines generally use a wind sensor mechanism coupled with a motor to move the turbine. Most turbines have a gearbox, which turns the slow rotation of the blades into a quicker rotation that is more suitable to drive an electrical generator.

Since towers produce turbulence behind, the turbine is usually positioned upwind of its supporting tower. Turbine blades are made stiff to prevent the blades from being pushed into the tower by high winds. Downwind machines have also been built before, despite the problem of turbulence (mast wake), because they don't need an additional mechanism for keeping them in line with the wind, and because in high winds the blades can be allowed to bend which effectively reduces their swept area and thus their wind resistance but this mechanism has a lot of fatigue and may lead to premature failure and thus most HAWTS are of upwind design.

Huge turbines used on wind farms for commercial production of electric power are usually three-bladed and pointed into the wind by computer-controlled motors. These can have very high tip speeds of over 300 km/h (high efficiency, and low torque ripple, which contribute to good reliability). The turbine blades are usually colored in white for daytime visibility by aircraft and range in length from 5 to 40 meters or more. The tubular steel towers can range from 60 to 90 meters high. The blades rotate at 10 to 22 revolutions per minute. At 22 rotations per minute the tip speed exceeds 90 meters per second. A gear box is commonly used for stepping up the speed of the generator, although

designs may also use direct drive of an annular generator. Some models operate at constant speed, but more energy can be collected by variable-speed turbines which use a solid-state power converter to interface to the transmission system. All turbines are equipped with protective features to avoid damage at high wind speeds, by feathering the blades into the wind which ceases their rotation, supplemented by brakes (Masters, 2004).

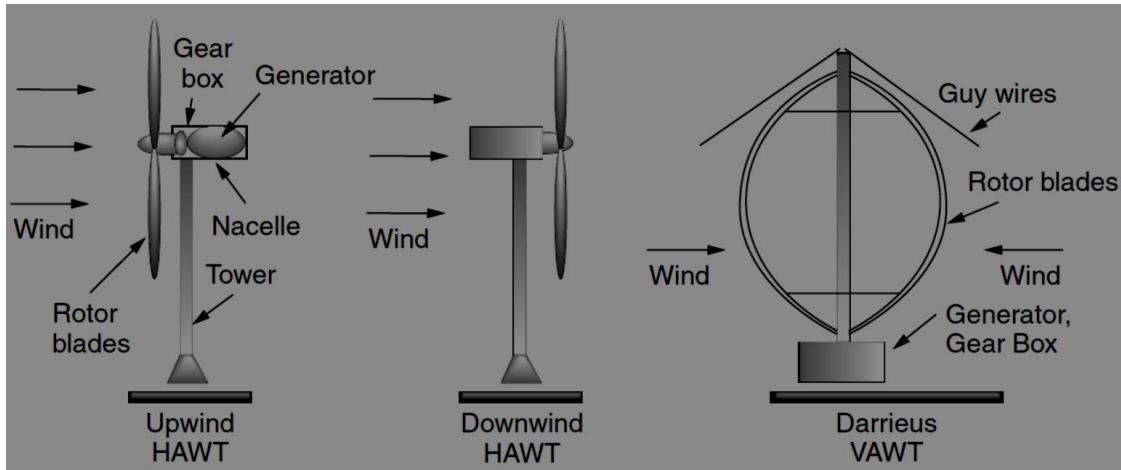

Figure 2.11: The figure illustrates the types of Wind turbines (Masters, 2004).

HAWTs can be mono-blade, twin blade, three blade or even multi bladed. Mono-blade wind turbines have lighter rotors and the length of the rotors varies from 15m to 25m, for extremely long rotors a counter weight may be required to balance the blades centrifugal forces. Some of the advantages offered by mono-blade rotor designs are that:-

- The blade is easier to install since it can be assembled on the ground
- The gear box ratio is reduced since they move relatively faster than the other types

Some of the disadvantages include of these mono blades are:-

- The added weight of the counter balance which negates the benefits of light design.
- Higher speeds cause more noise and these have environmental effects.

The twin blade type of turbines face the difficulty of imbalance at high speeds, this is because the forces on the blade at the upper position are higher than the forces at the bottom position.

Due to the difference in the forces the rotor experiences very high vibrations which can lead to failure during orientation of the nacelle into the wind direction, but tethering control can be provided to counter this. Tethering control provides for the axis to be aligned at an angle, such that the turbine revolves in a slanting position at high velocities, this can also be done for the mono blade systems.

The three blade turbines offer the advantage of balance of gyroscopic forces and they rotate much slower and hence it is not necessary to have tethering control in this system. In the three blade system the position of the nacelle changes automatically according to the wind direction by use of a wind vane at the tail of the nacelle, in large systems an electromagnetic system is required. Figure 2.15 illustrates the parts of a HAWT system and Figure 2.16 shows the principle of aerodynamic lift on a twin blade HAWT (Masters, 2004).

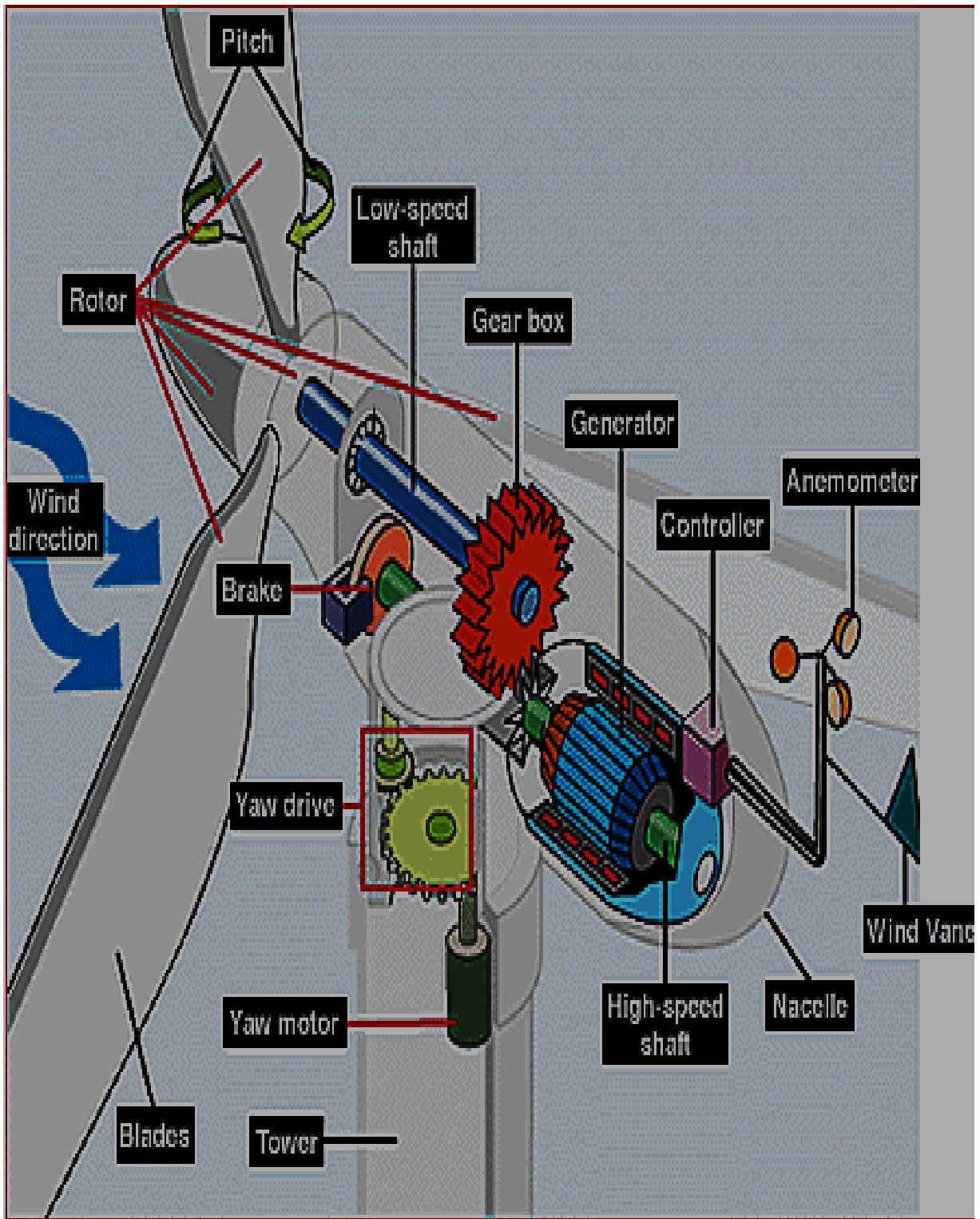

Figure 2.12: The figure shows the different parts of a horizontal axis wind turbines (HAWT) (Mwanza, 2014).

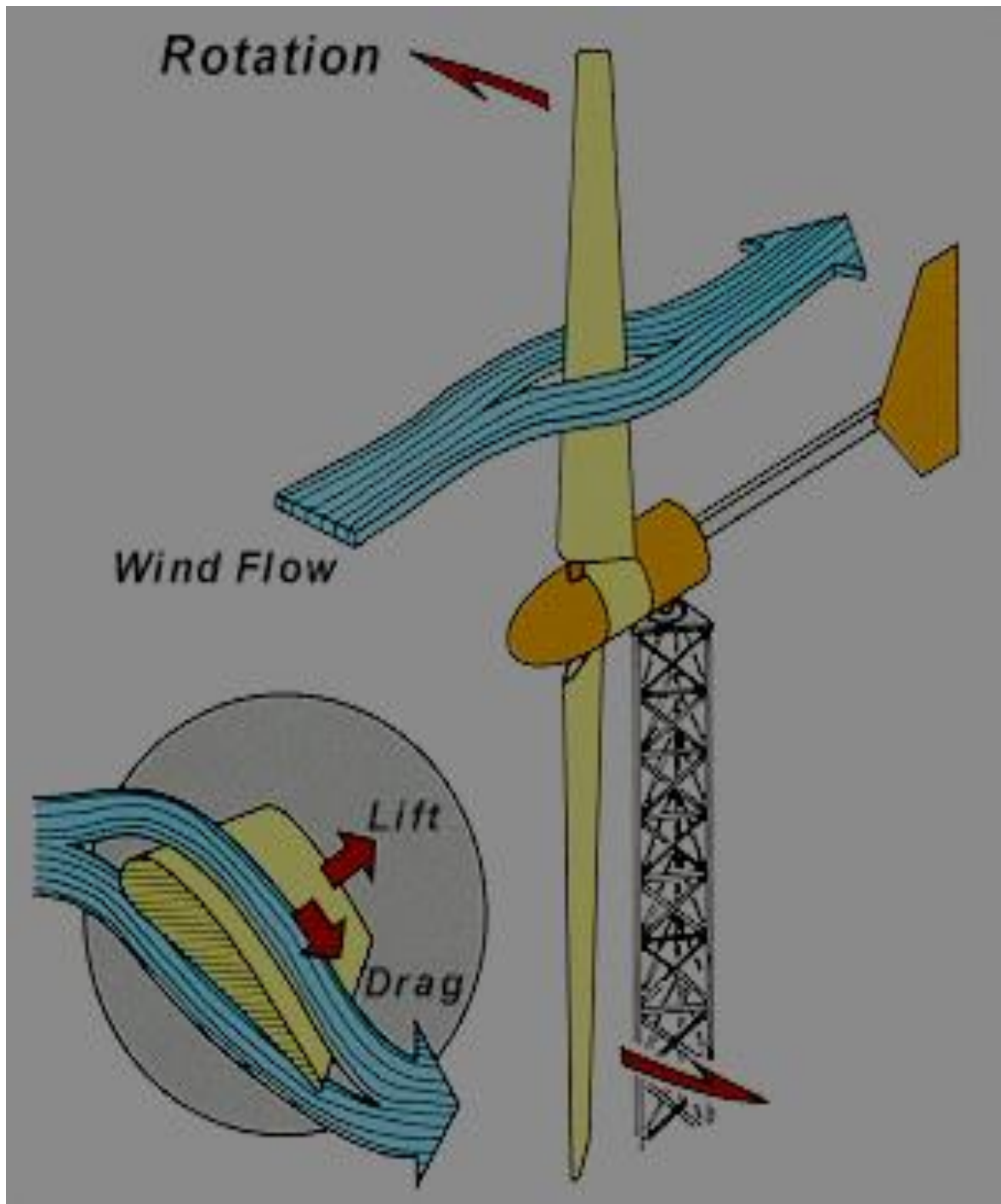

Figure 2.13: The figure shows an illustration of the principle of wind turbine aerodynamic lift (Darling, 2014).

2.4.3.2 Vertical-axis wind turbines (VAWTs)

These are a type of wind turbine where the main rotor shaft is set in the vertical axis and the main components are located at the base of the turbine. This arrangement allows the generator and gearbox to be located close to the ground and this eases access for service and repair. VAWTs do not necessarily need to be pointed into the wind, which removes the need for wind-sensing and orientation mechanisms. Major drawbacks for the early designs such as the *Savonius* and the *Darrieus* included the significant torque variation during each revolution, and the huge bending moments on the blades (Mwenda, 2014).

2.4.4 Wind Speeds in Zambia

A critical input that must be studied and understood extensively for wind turbine to work successfully are the wind speeds and these are shown in Table 2.1, these averages were taken by the meteorological department in the various districts at an approximate height of 10m above ground over a period ranging from 2 to 30 years (Mwenda, 2014).

Table 2.1: The table shows the average wind speeds in Zambia taken by the Meteorological department (Mwenda, 2014).

No.	Station	Province	Longitude	Latitude	Average wind speed v (m/s)	Number of years of data collection
1.	Chipata	Eastern	32.58	-13.57	4	28
2.	Chipepo	Central	27.88	-16.8	5.2	2
3.	Choma	Southern	27.07	-16.85	3.1	30
4.	Isoka	Northern	32.63	-10.17	1.9	24
5.	Kabompo	North Western	24.2	-13.6	1.5	29
6.	Kabwe (Met.)	Central	28.48	-14.42	5.9	27
7.	Kabwe (Agric)	Central	28.50	-14.40	3.3	30
8.	Kafironda	Copperbelt	28.17	-12.63	1.8	30
9.	Kafue	Lusaka	27.92	-15.77	3.8	28
10.	Kalabo	Western	22.7	-14.95	4.9	11
11.	Kaoma	Western	24.80	-14.80	1.8	29
12.	Kasama	Northern	31.13	-10.22		
13.	Kasempa	North Western	25.83	-13.47		
14.	Kawambwa	Luapula	29.25	-9.8	2.4	18

15.	Livingstone	Southern	25.82	-17.82	3.6	17
16.	Lundazi	Eastern	33.2	-12.28	2.3	23
17.	Lusaka	Lusaka	28.32	-15.42	5	16
18.	Lusaka (Airport)	Lusaka	28.43	-15.32		
19.	Lusitu	Southern	27.63	-16.18	5	6
20.	Magoye	Southern	27.63	-16.13	3.5	24
21.	Mansa	Luapula	28.85	-11.10	3.2	24
22.	Mbala	Northern	31.33	-8.85	3.8	30
23.	Mfuwe	Eastern	31.93	-13.27	2.6	24
24.	Misamfu		31.22	-10.18	3.6	30
25.	Mkushi	Central	29.00	-13.60	5.5	3
26.	Mongu	Western	23.17	-15.25	5.9	17
27.	Mpika	Northern	31.43	-11.90	3.4	27
28.	Msekera	Copperbelt	32.57	-15.55	3.5	20
29.	Mount Makulu	Lusaka	28.32	-15.55	3.5	28
30.	Mumbwa	Central	27.07	-14.98	2.7	21
31.	Mwinilunga	North Western	24.43	-11.75	2.4	29
32.	Ndola	Copperbelt	28.66	-13.00		
33.	Petauke	Eastern	31.28	-14.25	3.2	29
34.	Samfya	Luapula	29.32	-11.21	3.4	7
35.	Senanga	Western	23.27	-16.12	3.3	22
36.	Serenje	Central	30.22	-13.23	3.2	22
37.	Sesheke	Western	24.30	-17.47	3.1	29
38.	Solwezi	North Western	26.38	-12.18	2.9	29
39.	Zambezi	North Western	23.12	-13.53	3.1	29

The average wind speeds in Zambia vary from 1.5 to about 5.9m/s, more wind can be harnessed by increasing the tower height of the turbines, as will be illustrated later in this chapter.

2.4.4.1 Variation Of Wind Speeds With Height Above Ground

Wind speed near the ground is greatly affected by the friction that air experiences, smooth surfaces such as the sea experience less friction and rough surfaces such as populated cities with tall buildings

experience more friction and the wind speed is a function of the height and the Earth's surface attributes (Mwanza, 2014).

In the United states the Power law is often used to take into account the tower height, the power law is given as:

$$\left(\frac{v}{v_0}\right) = \left(\frac{H}{H_0}\right)^\alpha$$

Equation 2.12

Where: H_0 is the reference height of 10m in our case

V_0 is the reference wind speed at H_0

α is the friction coefficient

An alternative law is used in Europe and it is given below.

$$\left(\frac{v}{v_0}\right) = \frac{\ln(H/z)}{\ln(H_0/z)}$$

Equation 2.13

Where: Z = roughness length

The two equations give only an approximation and it should be noted that nothing is better than actual site measurements. Tables 2.2 and 2.3 give characteristics for use in equations 2.6 and 2.7 (Mwanza, 2014).

Table 2.2: The table shows the terrain characteristics and friction coefficients (Mwanza, 2014).

Terrain Characteristics	Friction Coefficient α
Smooth hard ground, calm water	0.10
Tall grass on level ground	0.15
High crops, hedges and shrubs	0.20
Wooded countryside, many trees	0.25
Small town with trees and shrubs	0.30
Large city with tall buildings	0.40

Table 2.3: The table shows the terrain characteristics and roughness heights (Mwanza, 2014).

Roughness Class	Description	Roughness Length $z(m)$
0	Water surface	0.0002
1	Open areas with a few windbreaks	0.03
2	Farm land with some windbreaks more than 1 km apart	0.1
3	Urban districts and farm land with many windbreaks	0.4
4	Dense urban or forest	1.6

2.4.5 Airfoil design

Airfoils are structures with special geometric shapes, used to generate mechanical forces due to the relative motion of the airfoil and a surrounding fluid mostly air. Wind turbine blades use these airfoils to develop mechanical power. The width and length of the blades are functions of the desired aerodynamic performance, the maximum desired rotor power, the assumed airfoil properties and strength considerations. An airfoil's shape is defined by several parameters, which are shown in Figure 2.17 below (Mwenda, 2014).

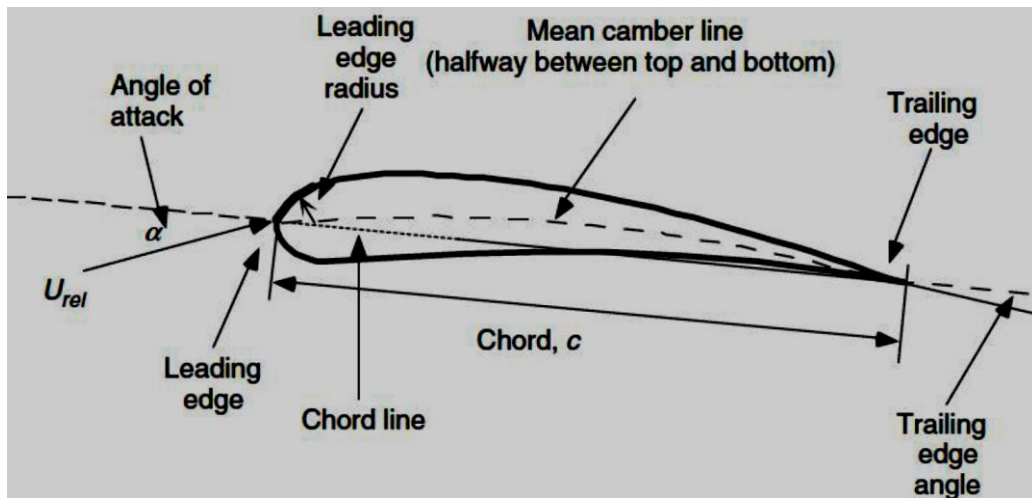

Figure 2.14: The figure shows airfoil design parameters (Mwenda, 2014).

The parameters on an Airfoil are Defined as follows:-

- 1) **Chord Line** = Straight line drawn from the leading edge to the trailing edge.
- 2) **Chord Length (C)** = Length of the chord line.
- 3) **Mean Camber Line** = Curved line from the leading edge to the trailing edge, which is equidistant between the upper and lower surfaces of the Airfoil.
- 4) **Maximum (or Just) Camber** = Maximum distance between the chord line and the mean camber line.
- 5) **Maximum Thickness** = Maximum distance between the upper and lower surfaces of the airfoil normal to the chord line.
- 6) **Span** = Width of the Airfoil.
- 7) **Angle of Attack** = Angle between the chord line and the stream-wise flow direction.
- 8) **Zero Lift Angle of Attack** = Angle of Attack that will produce no lift. For our symmetric wedge this would be an angle of attack of zero.
- 9) **Stall Angle of Attack** = Angle of attack at which there is maximum lift (or lift coefficient).

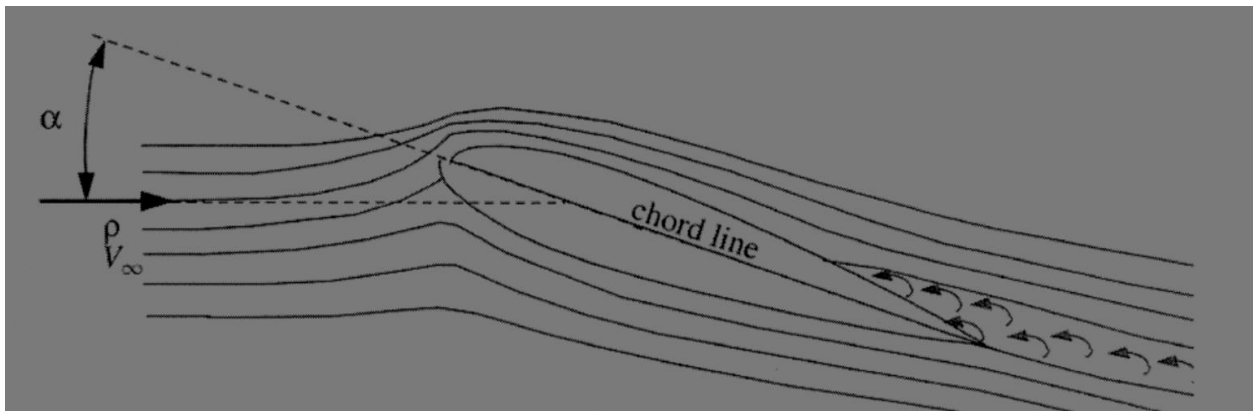

Figure 2.15: The figure shows the angle of attack and the chord line on an airfoil (Mwenda, 2014).

- 10) **Symmetric or Uncambered Airfoil** = Upper and lower surfaces are mirror images, which leads to the mean camber line to be coincident with the chord line. A symmetric Airfoil will also have a just camber of zero.
- 11) **Cambered Airfoil** = An asymmetric Airfoil for which the mean camber line will be above the chord line.

Figures 2.18 and 2.19 illustrate the angle of attack and the camber on an airfoil respectively

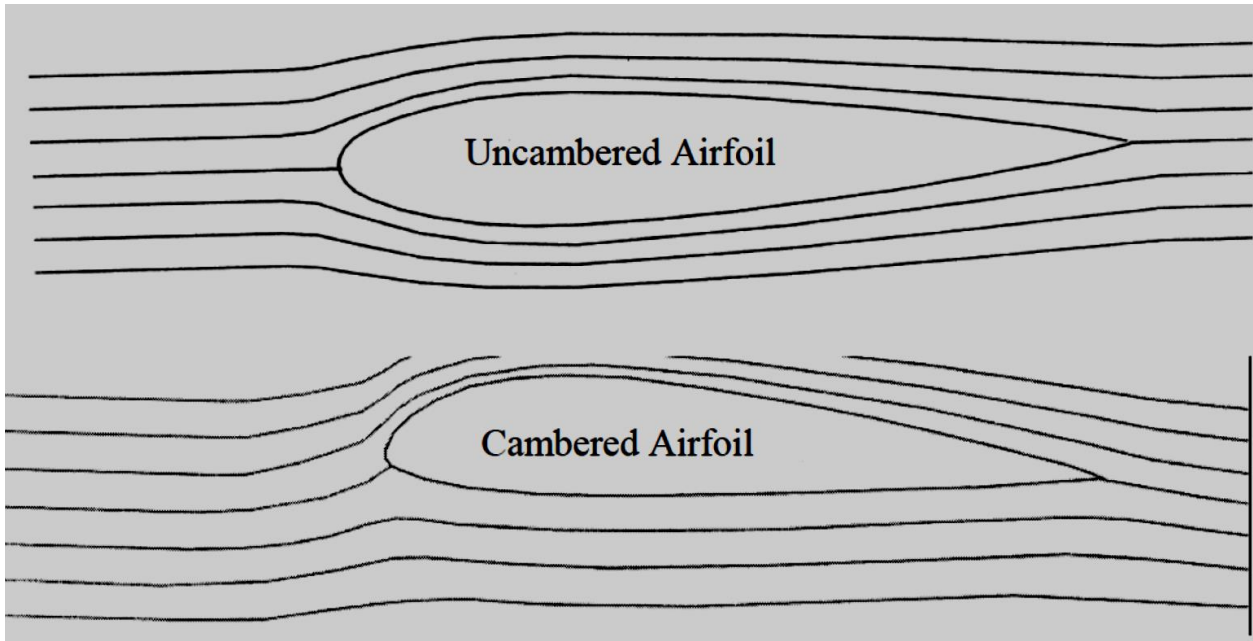

Figure 2.16: A cambered and an uncambered Airfoil (Masters, 2004).

- 12) **Pitching Moment** = Torque or moment created on the wing due to net lift and drag forces, this tends to rotate the leading edge either up or down.
- 13) **Pitching Moment Coefficient C_m** = the pitching moment coefficient is given as below.

$$C_m = \frac{m}{\frac{1}{2} \rho V^2 S c}$$

Equation 2.14

Where: m = pitching moment (this will depend on the moment reference center).
 C = the chord length.

- 14) **Center of Pressure** = the moment reference center for which the moment is zero, this depends on the angle of attack.
- 15) **Aerodynamic Center** = the moment reference center for which the moment does not vary with angle of attack.

2.4.5.1 NACA Classified Airfoils

Various airfoils have been tested and classified by the National Advisory Committee for Aeronautics (NACA), the forerunner of NASA, and have been cataloged using a four digit code. Hence a specific airfoil can be identified by NACA WXYZ.

Where: **W** is the maximum camber as percent of the chord length.

X is the Location of the maximum camber form the leading edge along the chord line in tenths of chord length.

Y&Z are the Maximum thickness in percent of the chord length.

Every NACA type airfoil has several charts to present the lift, drag, moment coefficient and other data for the airfoil. The first chart will usually have curves of lift coefficient versus angle of attack at various Reynolds numbers and curves of moment coefficient at the quarter chord point versus angle of attack at various Reynolds numbers as shown on the chart below. In addition to the lift and moment coefficients, the stall angle of attack and zero lift angle of attack can be determined. The second chart will usually have curves of drag coefficient versus lift coefficient at various Reynolds numbers and curves of moment coefficient at the aero dynamic center versus lift coefficient at various Reynolds numbers. In addition to smooth airfoils, it is common for data for an airfoil whose leading edge has a rough surface texture to be included. The data shown in the following charts is for the NACA 2412 generic airfoil (Mwenda, 2014).

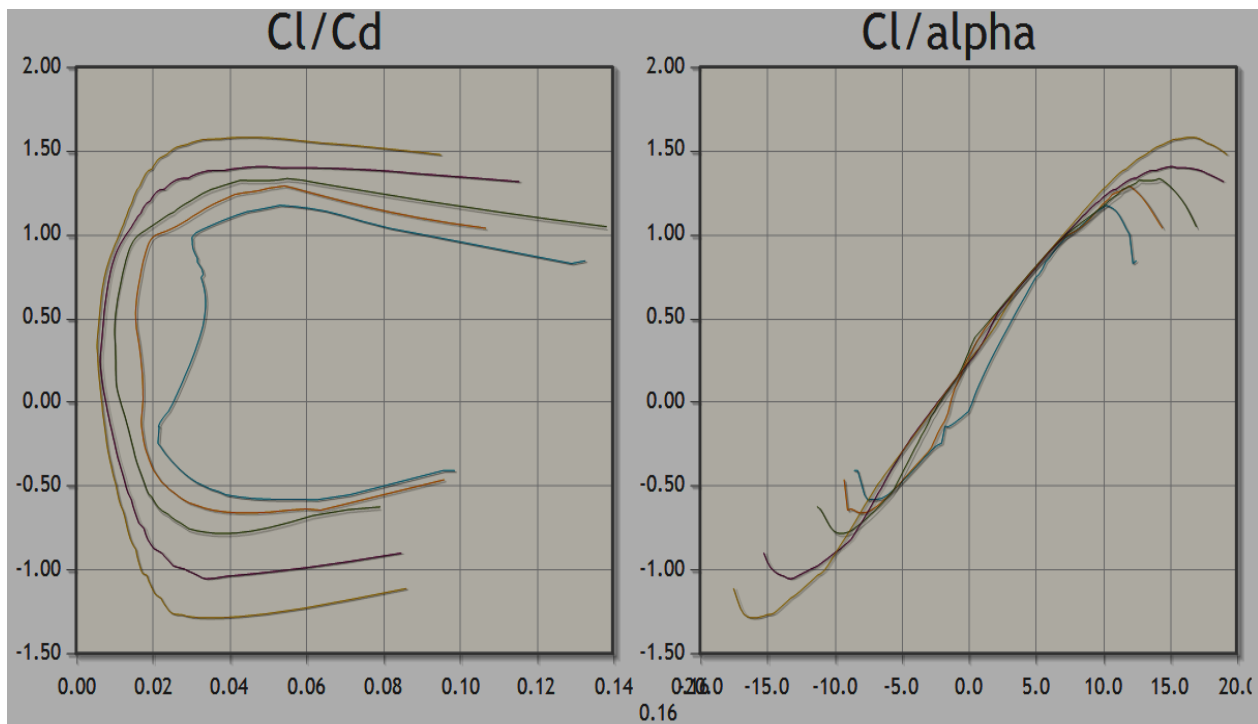

Figure 2.17: The figure shows NACA 2412 Airfoil charts for lift coefficient (C_L) vs drag coefficient (C_D), and for lift coefficient (C_L) vs the attack angle α (Airfoil tools, 2014).

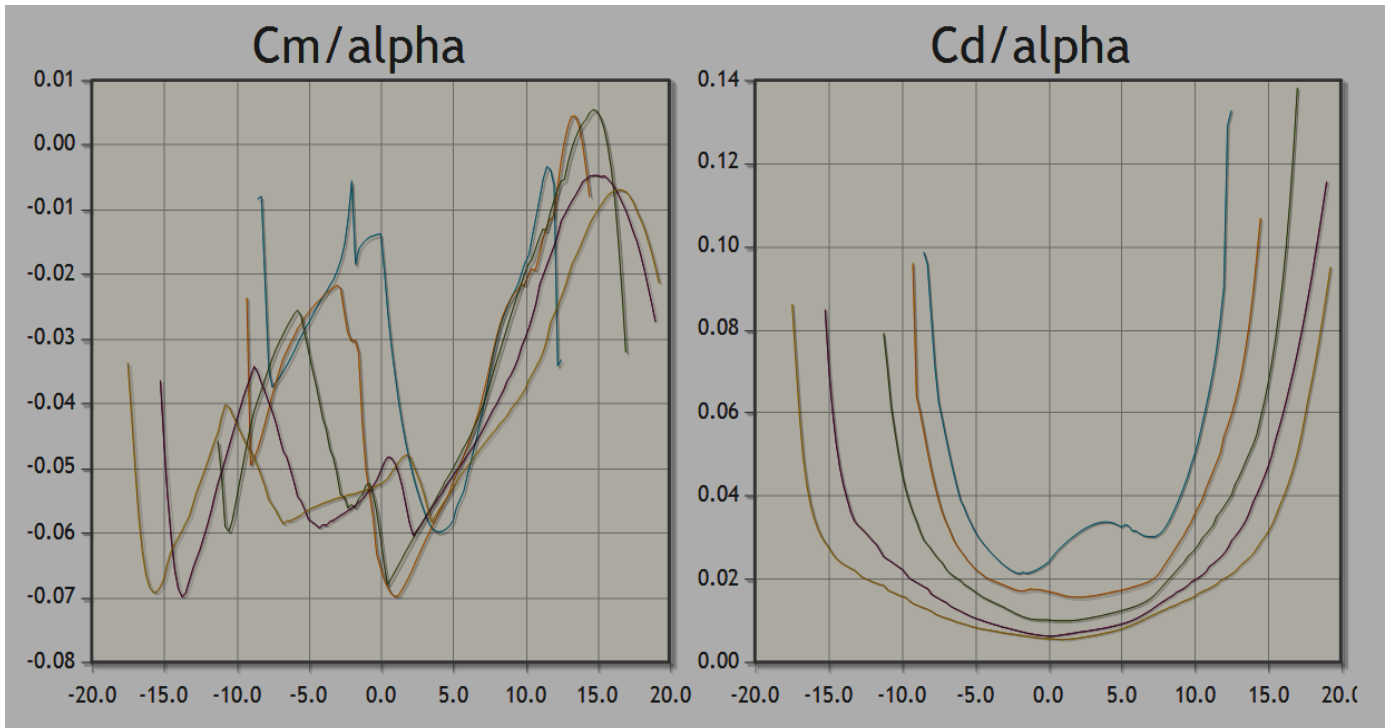

Figure 2.18: the figure shows the NACA 2412 Airfoil charts for moment coefficient (C_M) vs the attack angle α and for draft coefficient (C_D) vs the attack angle α (Airfoil tools, 2014).

When using NACA airfoil Charts, the following needs to be done:-

- 1) Determination of the angle of attack depending on the airfoil design.
- 2) The angle of attack is then used to determine the lift coefficient from Chart number 2.
- 3) Using the angle of attack, the moment coefficient at the quarter chord point from Chart number 3 can be determined.
- 4) Using the lift coefficient, the drag coefficient from Chart number 1 can be determined.

To factor in the compressibility for Mach numbers less than 0.3, it can be assumed that our flow is incompressible and the standard airfoil charts work very well. For Mach numbers greater than 0.3, we must correct the lift coefficient using the *Prandtl-Glauert* correction which gives:-

$$c_L = \frac{c_{L,chart}}{\sqrt{1 - M_\infty^2}}$$

Equation 2.15

This equation is valid for Mach numbers up to 0.7.

Figure 2.22 shows a generic NACA 2412 type airfoil with maximum thickness at 12 percent, maximum camber at 2 percent at 40 percent chord (Airfoil tools, 2014).

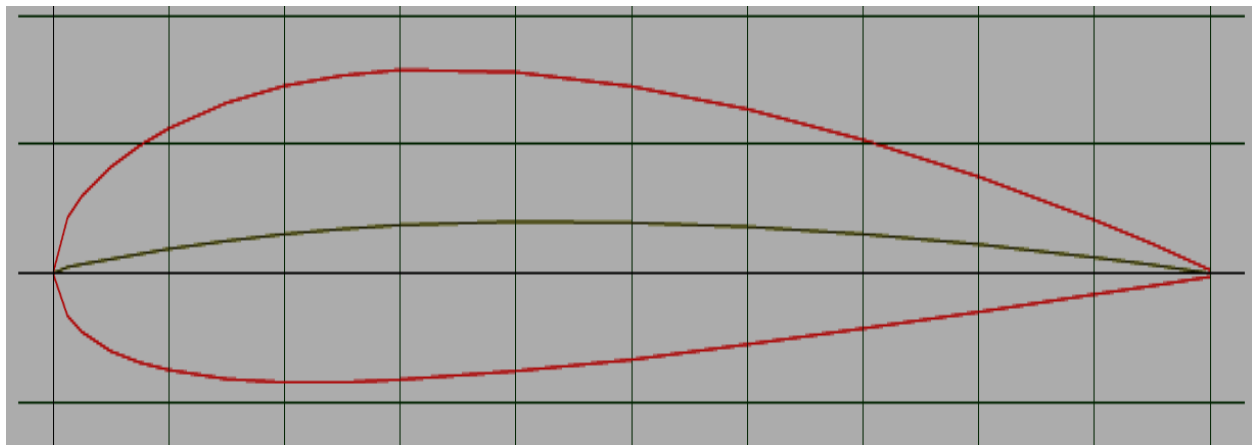

Figure 2.19: The figure shows the generic NACA 2412 airfoil (Airfoil tools, 2014).

2.4.5.2 NREL Airfoil Families

Over the past decade, commonly used airfoil families for horizontal axis wind turbines (HAWTs) have included the NACA 44XX, NACA 23XXX, NACA 63XXX, and NASA LS (1) series airfoils. All these airfoils suffer noticeable performance degradation from roughness effects resulting from leading-edge contamination. Annual energy losses due to leading-edge roughness are greatest for stall-regulated rotors. The loss is largely proportional to the reduction in maximum lift coefficient (C_{Lmax}) along the blade. High blade-root twist helps reduce the loss by keeping the blade's angle-of-attack distribution away from stall which delays the onset of C_{Lmax} . The roughness also degrades the airfoil's lift-curve slope and increases the profile drag, which contributes to further losses (Tangler and Somers, 1995).

For stall regulated rotors, whose angle of attack distribution increases with wind speed, the annual energy loss can be 20 to 30 percent where leading edge contamination from insects and airborne pollutants is common. Variable-pitch toward stall would result in similar roughness losses as fixed-pitch, stall regulation, while variable-pitch toward feather would decrease the loss to around 10 percent at the expense of the rotor being susceptible to power spikes in turbulent high winds. For variable-rpm rotors operating at constant tip-speed ratio and angle of attack distribution, the loss is minimal at around 5 to 10 percent.

To minimize the energy losses due to roughness effects and to develop special-purpose airfoils for HAWTs, the National Renewable Energy Laboratory (NREL), formerly the Solar Energy Research Institute (SERI) and Airfoils Inc. began a joint airfoil development effort in 1984. The estimated annual energy improvements and the component improvements from the NREL airfoils for stall-regulated, variable-pitch, and variable rpm rotors are shown in Table 2.4 (Tangler and Somers, 1995).

Table 2.4: The table shows the estimated annual energy improvements on NREL airfoil families (Tangler and Somers, 1995).

Turbine types	Roughness Insensitive C_{Lmax}	Correct Reynolds Number	Low TIP C_{Lmax}	Total Improvement
Stall-Regulated	10% to 15%	3% to 5%	10% to 15%	23% to 35%
Variable- Pitch	5% to 15%	3% to 5%	-	8% to 20%
Variable-RPM	5%	3% to 5%	-	8% to 10%

By using the NREL airfoils, which are specifically designed for HAWTs, the annual energy production loss due to airfoil roughness effects can be cut in half relative to previously used aircraft airfoils. Optimizing an airfoil's performance characteristics for the appropriate Reynolds number and thickness provides additional performance enhancement in the range of three to five percent.

Aircraft airfoils used on wind-turbine blades are often used at a lower Reynolds number than that intended by their designers. In addition, the airfoils are often scaled to a greater thickness, which often leads to undesirable performance characteristics. The performance characteristics of the NACA 23XXX series of airfoils, for example, deteriorate quite rapidly with increasing airfoil thickness.

This problem is further compounded in the blade root area by combining a low Reynolds number with high thickness. Such a combination normally makes it difficult to achieve good airfoil performance characteristics. For stall-regulated rotors, further performance enhancement is achieved by using blade outboard airfoils with low C_{Lmax} which helps control peak rotor power. This allows the use of 10 to 15 percent more swept rotor area for a given generator size.

Nine airfoil families consisting of 25 airfoils have been designed for various size rotors since 1984. The appropriate blade length and generator size for each airfoil family along with the corresponding airfoils comprising each family from blade root to tip are shown in Table 2.5. The airfoil designations starting with the S801 and ending with the S828 represent the numerical order in which the airfoils were designed between 1984 and 1995. The "A" designation stands for an improved version of an airfoil based on wind-tunnel test results for a similar airfoil. The three airfoils having underlined bold lettering have undergone comprehensive tests in the Delft University low-turbulence wind tunnel.

Seven of the airfoil families are designated "thick" which indicates that the outer-blade airfoils are 16 to 21percent thick. Greater thickness helps provide greater blade flap stiffness for tower clearance, lower blade weight important for large machines, and helps accommodate aerodynamic over speed control devices for stall-regulated machines. The two airfoil families labeled "thin" (11 to 15 percent) are more suited to downwind rotors of small to medium blade length. For most all blades, very thick airfoils are desired for the blade-root to accommodate structural and dynamic considerations. The

blade-root airfoil thickness falls in the range of 18 to 24 percent. Thicknesses greater than 26 percent were found to result in undesirable performance characteristics (Tangler and Somers, 1995).

Table 2.5: The table shows a summary of NREL Airfoil families(Tangler and Somers, 1995).

Blade Length (meters)	Generator (kW)	Thickness Category	Airfoil Family (root-----tip)			
1-5	2-20	thick		S823		S822
5-10	20-150	thin		S804	S801#	S803#
5-10	20-150	thin	S808	S807	S805A	S806A
5-10	20-150	thick		S821	S819	S820
10-15	150-400	thick	S815	S814	S809	S810
10-15	150-400	thick	S815	S814	S812	S813
10-15	150-400	thick	S815	S814	S825#	S826#
15-25	400-1000	thick		S818	S816	S817
15-25	400-1000	thick		S818	S827	S828

2.4.5.3 Airfoil materials

Table 2.6 summarizes the common airfoil materials in common use.

Table 2.6: A summary of airfoil materials and their properties according (Mwanza, 2014).

Parameter	Spec. weight	Strength limit	Modulus of elasticity	Spec. breaking strength	Spec. modulus of elasticity	Fatigue strength
Material	γ g/cm ³	σ_B N/mm ²	E kN/mm ²	σ_B/γ km	E/γ 10 ³ km	$\pm\sigma_A$ 10 ⁷ N/mm ²
Steel St 52	7.85	520	210	6.6	2.7	60
Alloyed steel 1.7735.4	7.85	680	210	8.7	2.7	70
Aluminium AlZnMgCu	2.7	480	70	18	2.6	40
Aluminium AlMg5 (weldable)	2.7	236	70	8.7	2.6	20
Titanium alloy 3.7164.1	4.5	900	110	20	2.4	—
Fibre glass/epoxy* composite	1.7	420	15	24.7	0.9	35
Carbon fibre/ epoxy* composite	1.4	550	44	39	3.1	100
Aramide fibre/ epoxy* composite	1.25	450	24	36	1.9	—
Wood (Sitka Spruce)	0.38	appr. 65	appr. 8	appr. 17	appr. 2.1	appr. 20
Wood/epoxy*	0.58	appr. 75	appr. 11	appr. 13	appr. 1.9	appr. 35

2.4.6 Advantages of Wind Energy

Wind energy does offer several advantages and they include:-

- 1) The wind is free and with modern technology it can be captured and used even more efficiently.
- 2) Once the wind turbine is built the energy it produces does not cause greenhouse gases or other pollutants.
- 3) Although wind turbines can be very large each takes up only a small plot of land. This means that the land below can still be used. This is especially the case in agricultural areas as farming can still continue.
- 4) Many people find wind farms an interesting feature of the landscape and can thus be used for tourism.
- 5) Remote areas that are not connected to the electricity power grid can use wind turbines to produce their own supply.
- 6) Wind turbines are available in a range of sizes which means a vast range of people and businesses can use them. Single households to small towns and villages can make good use of range of wind turbines available today.

2.4.7 Disadvantages of Wind Energy

Although various advantages have been outlined above, wind energy has still got challenges associated with it and they include:-

- 1) The speed of the wind is not constant and it can vary from zero to storm force. This means that wind turbines do not produce the same amount of electricity all the time; there will be times when they produce no electricity at all.
- 2) Many people feel that the countryside should be left untouched, without these large structures being built. The landscape should be left in its natural form for everyone to enjoy.
- 3) Wind turbines are noisy and each one can generate the same level of noise as a family car travelling at 70 mph.
- 4) When wind turbines are being manufactured some pollution is produced. Therefore wind power does produce some level of pollution.
- 5) Large wind farms are needed to provide entire communities with enough electricity. For example, the largest single turbine available today can only provide enough electricity for 475 homes, when running at full capacity. How many would be needed for a town of 100 000 people.

2.5 Generator Types in Wind turbines

There are four main types of wind turbines generators (Mwanza, 2014)

- Type 1: Induction machine; treated as PQ bus with negative P load
- Type 2: Induction machine with varying rotor resistance; treated as Type 1
- Type 3: Doubly Fed Induction Generator (DFIG); treated as a PV bus
- Type 4: Full Asynchronous Generator; treated as a PV bus

The type 1 machines are the conventional induction generators (fixed speed) and are illustrated below

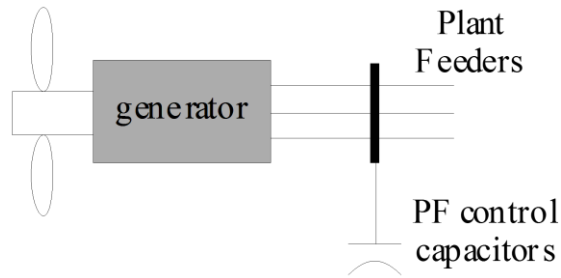

Figure 2.20: Conventional induction generators (Mwanza, 2014).

The Type 2 machines are the Wound-rotor Induction Generator with variable rotor resistance as shown below

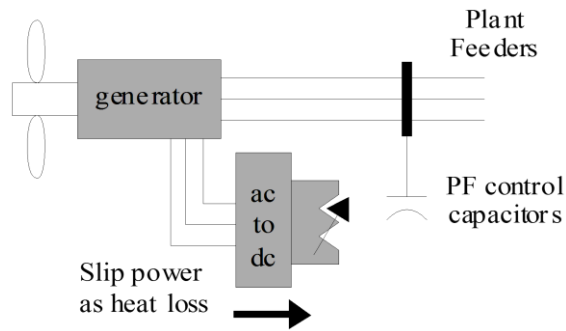

Figure 2.21: Wound-rotor Induction Generator (Mwanza, 2014).

The Type 3 machines are the Doubly-Fed Induction Generator (variable speed) and are depicted below

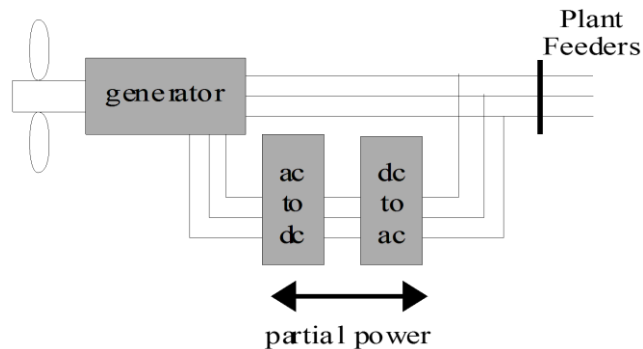

Figure 2.22: Doubly-Fed Induction Generator (Mwanza, 2014).

The Type 4 machines have a full converter interface and are depicted below

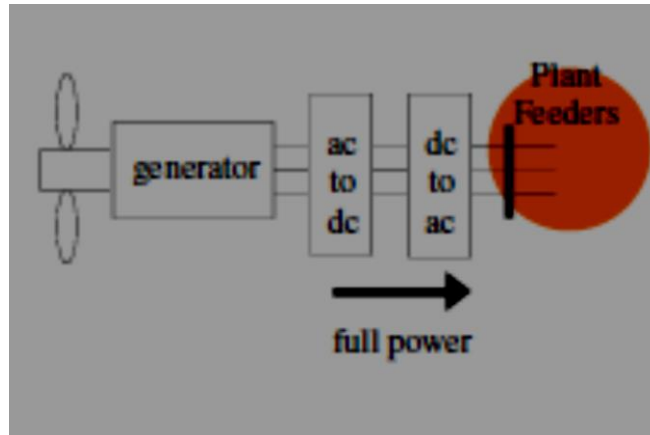

Figure 2.23: Full converter interface generator (Mwanza, 2014).

The other types of generators are:-

- Synchronous generator(with external field excitation)
- Permanent Magnet(PM) synchronous generator

These are the cheapest and most widely used type of generator in small wind turbines.

The specific types of generators that are used for wind turbines are as listed below.

1. Motor vehicle alternators.
2. Permanent magnet generators (PMG).
3. Axial flux permanent magnet generators (AFPMG).
4. Permanent Magnet DC motor used as a generator.

Motor vehicle alternators can be used in wind turbine generators for power generation, but they are not suitable for micro wind turbine generators because they produce electricity only at high rotational speeds of up to 3000rpm, this can only be achieved if the wind turbine is fitted with a gear box which is costly and undesirable since it also increases the cut in speed of the turbine and it may not work at low wind speeds. Further most of the new types of motor vehicle alternators require self-power for field excitation which increases the cost of the wind generator.

Permanent magnet generators are very suitable for wind turbine applications; these can be chosen according to the speed of operation of the turbine. These types of generators are not readily available in Zambia but can be imported fairly easily from the world market.

Another option is the axial flux permanent magnet generator (AFPMG) generators; these types of generators are very suitable and can be adapted to the wind application required because they can be easily manufactured. The only costly part of these generators is the magnets which are not readily

available locally but can be imported, the backdrop of these types of generators is that they require very strong and in this case rare earth magnets which are very costly and do not work well at high temperatures.

Permanent magnet DC motors can also be used as generator but they have to be carefully chosen to accommodate low speed applications. These types of motors are also not readily available in Zambia but can be purchased from the world market.

2.6 Energy Storage

For variable and intermittent energy sources like solar and wind Energy storage is required to improve on the load availability (Zulu, 2014). The Main types of energy storage include;

- 1) The Electrochemical battery.
- 2) The Flywheel.
- 3) Compressed air.
- 4) Superconducting coil.
- 5) Super capacitors.
- 6) Pumped water storage.

2.6.1 The battery

The types of batteries can be classified into two categories that is;

- 1) The Primary batteries or one way batteries with conversion efficiencies of 85-90 percent; and they are discarded after use, they cannot be recharged.
- 2) Secondary type is the two way or the rechargeable batteries with efficiencies of 70-80 percent.

The 6 major rechargeable electrochemical batteries at present include;

- 1) The Lead-acid (Pb-acid) batteries.
- 2) The Nickel-Cadmium (NiCd) batteries.
- 3) The Nickel-metal hydride (NiMH) batteries.
- 4) The Lithium-ion (Li-ion) batteries.
- 5) The Lithium-polymer (Li-poly) batteries.
- 6) The Zinc-air batteries.

The average cell voltage of each of the above mentioned batteries are summarized in the table below (Zulu, 2014).

Table 2.7: The table shows the characteristics of different types of batteries (Zulu, 2014).

Electrochemistry	Cell Voltage	Remark
Lead-acid	2.0	Least cost technology
Nickel-cadmium	1.2	Exhibits memory effect
Nickel-metal hydride	1.2	Temperature sensitive
Lithium-ion	3.4	Safe, contains no metallic lithium
Lithium-polymer	3.0	Contains metallic lithium
Zinc-air	1.2	Requires good air management to limit self-discharge rate

Another major characteristic of batteries is the Energy density and the energy densities of the various batteries are summarized in the table below in both the Watt-hour capacity per unit mass and per unit volume.

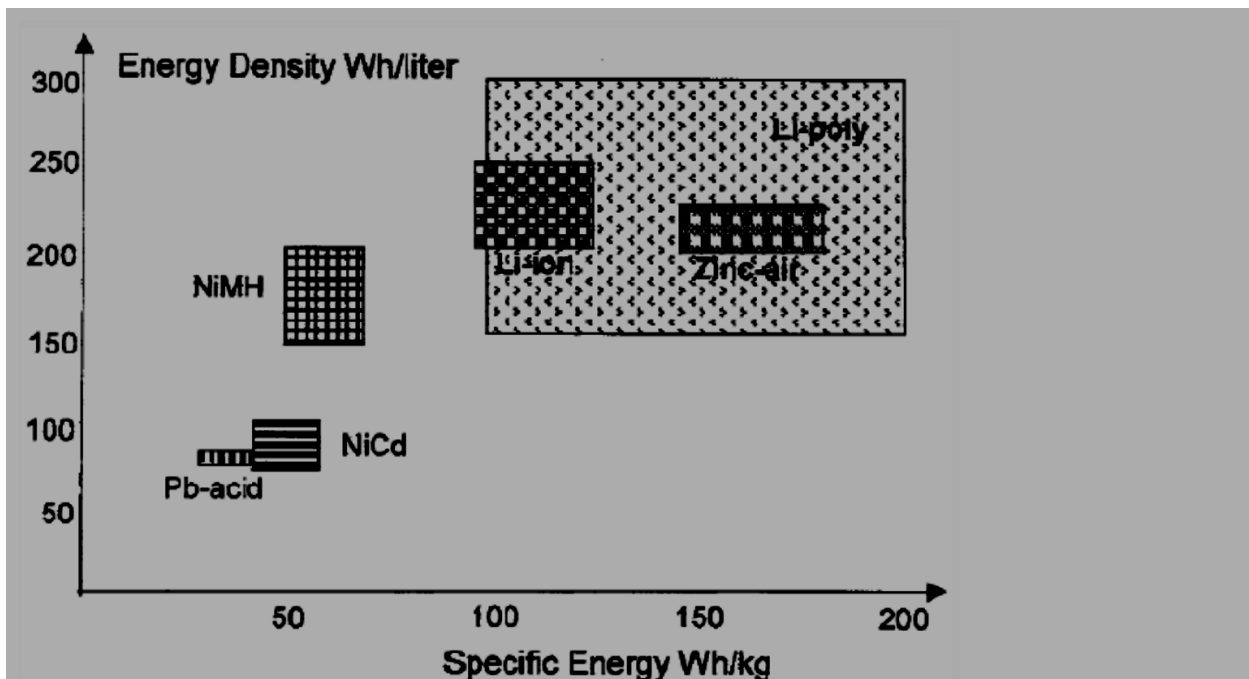

Figure 2.24: The figure compares the energy density and the specific energy of different types of batteries (Zulu, 2014).

One of the most common and mostly used types of rechargeable battery are the Lead acid battery, these types of batteries can be either Shallow cycle which are mostly used in automobiles and Deep-cycle for repeated charge and discharge which are very suitable for renewable energy storage. Table 2.8 gives a summary comparison of the specific energy, the energy density, the specific power and the power density while Table 2.9 gives a summary of the life and cost aspects of the different types of batteries.

Table 2.8: The table shows a summary comparison of the specific characteristics of different batteries (Zulu, 2014).

Electrochemistry	Specific Energy Wh/kg	Energy Density Wh/liter	Specific Power W/kg	Power Density W/liter
Lead-acid	30–40	70–75	~200	~400
Nickel-cadmium	40–60	70–100	150–200	220–350
Nickel-metal hydride	50–65	140–200	~150	450–500
Lithium-ion	90–120	200–250	200–220	400–500
Lithium-polymer	100–200	150–300	>200	>350
Zinc-air	140–180	200–220	~150	~200

Table 2.9: A summary of the life and cost aspects of the rechargeable batteries (Zulu, 2014).

Electrochemistry	Cycle life in full discharge cycles	Calendar life in years	Self discharge rate %/month at 25 °C	Relative cost \$/kWh
Lead-acid	500–1000	5–8	3–5	200–500
Nickel-cadmium	1000–2000	10–15	20–30	1500
Nickel-metal hydride	1000–2000	8–10	20–30	2500
Lithium-ion	500–1000	—	5–10	3000
Lithium-polymer	500–1000	—	1–2	>3000
Zinc-air	200–300	—	4–6	—

Monitoring and control of battery charge and discharge is very important (Zulu, 2014) as it defines the battery life and performance and in modern applications this is managed by dedicated computer software programs and hardware specifically for monitoring of;

- 1) The Voltage and current.
- 2) The Temperature and pressure in Amp-hours in and out of battery.
- 3) The State of charge and discharge.
- 4) The Depth of discharge.
- 5) The Number of charge and discharge cycles.

2.7 Hybrid Systems

Hybrid systems, as the name implies, combine two or more modes of electricity generation together, usually using renewable technologies such as solar photovoltaic (PV) and wind turbines. Hybrid systems provide a high level of energy security through the mix of generation methods and often will incorporate a storage system (battery, fuel cell) or small fossil fueled generator to ensure maximum supply reliability and security. Off grid renewable energy hybrid technologies satisfy energy demand directly and this avoids the need for long distribution infrastructures (Burch, 2001).

In the past 2 decades hybrid technology has developed and assumed a pivotal role as a renewable energy source. The benefits associated with hybrid technology for autonomous power production are almost unrivaled. Many rural and urban households around the world are utilizing hybrid systems. Isolated islands and places far from electric grids are trying to adopt this kind of technology because of the benefits which are associated with it in comparison with single renewable energy systems. The figure below illustrates a simplified layout of a hybrid Solar PV- Wind power system.

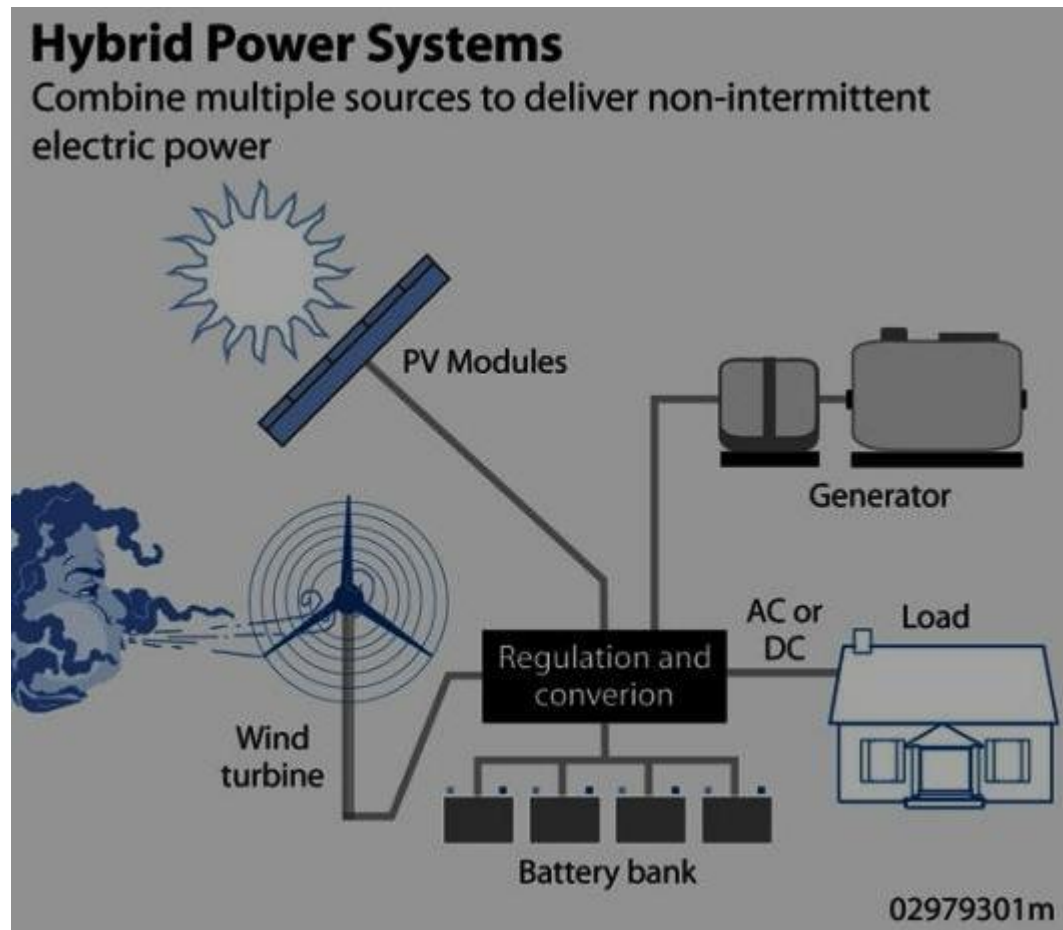

Figure 2.25: An illustration of hybrid system components (U.S Department of Energy, 2015).

Hybrid systems, more specifically Solar PV–Wind systems present many benefits and one of the biggest benefits of this type of system is the availability of the generating resource almost anywhere in the world.

With the high availability of wind and the use energy storage to rectify the erratic nature of wind and the unavailability of solar power during night time means that this system can provide useful energy almost all the time.

Another benefit is that it is economically sound and sustainable to use non finite resources and this coupled with the drastic reduction in emissions of greenhouse gases and pollutants makes solar/wind hybrid systems a pot of gold (Burch, 2001).

2.8 Power Electronic Converters (PEC)

Power electronic converter or PEC's are used to interface renewable energy system to the grid or to loads (Mwanza, 2014). The uses of PEC's include:-

- To invert DC generated from some energy sources to 50/60Hz AC used I n the grid.
- To couple/decouple a rotating generator from network in order to increase efficiency of operation of prime mover by ensuring it operates at its efficient speed for a range of input power.
- To link two AC networks.

There many different configurations that can be used in a distributed generation network and these include:-

1. A Power Converter connected in a Stand-alone AC System.

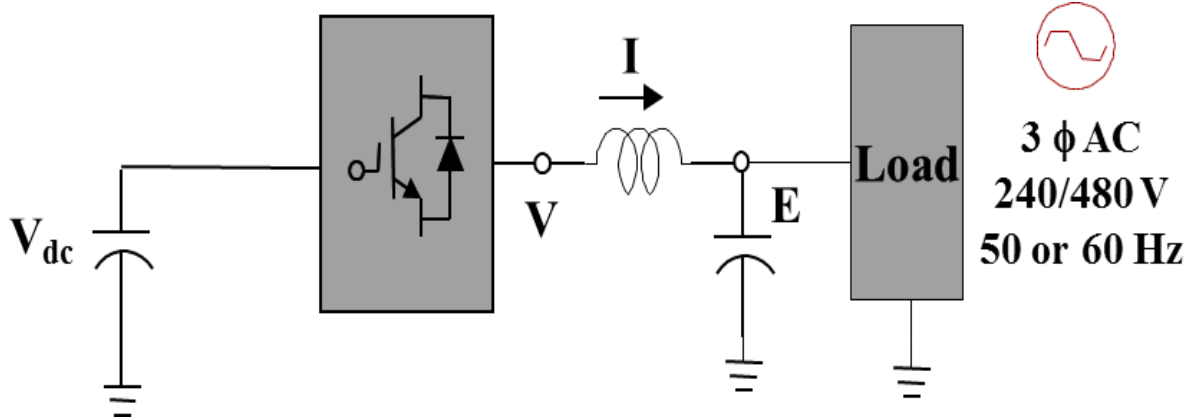

Figure 2.26: Block diagram of a Power Converter connected in a stand-alone AC system (Mwanza, 2014).

2. A Power Converter connected in Parallel with the Utility Mains.

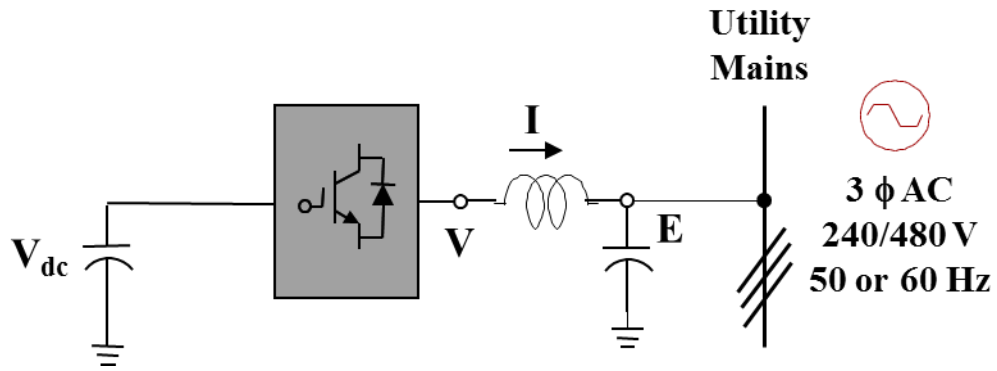

Figure 2.27: Block diagram of a Power Converter connected in parallel with the utility mains (Mwanza, 2014).

3. Paralleled-Connected Power Converters in a Stand-alone DC System.

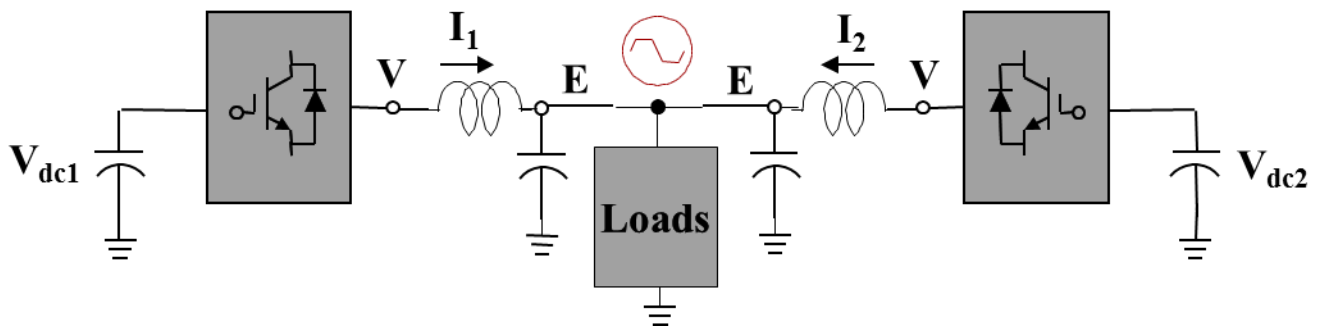

Figure 2.28: Block diagram of Paralleled-Connected Power Converters in a Stand-alone DC System (Mwanza, 2014).

4. Paralleled-Connected Power Converters with a common DC grid in a Stand-alone AC System.

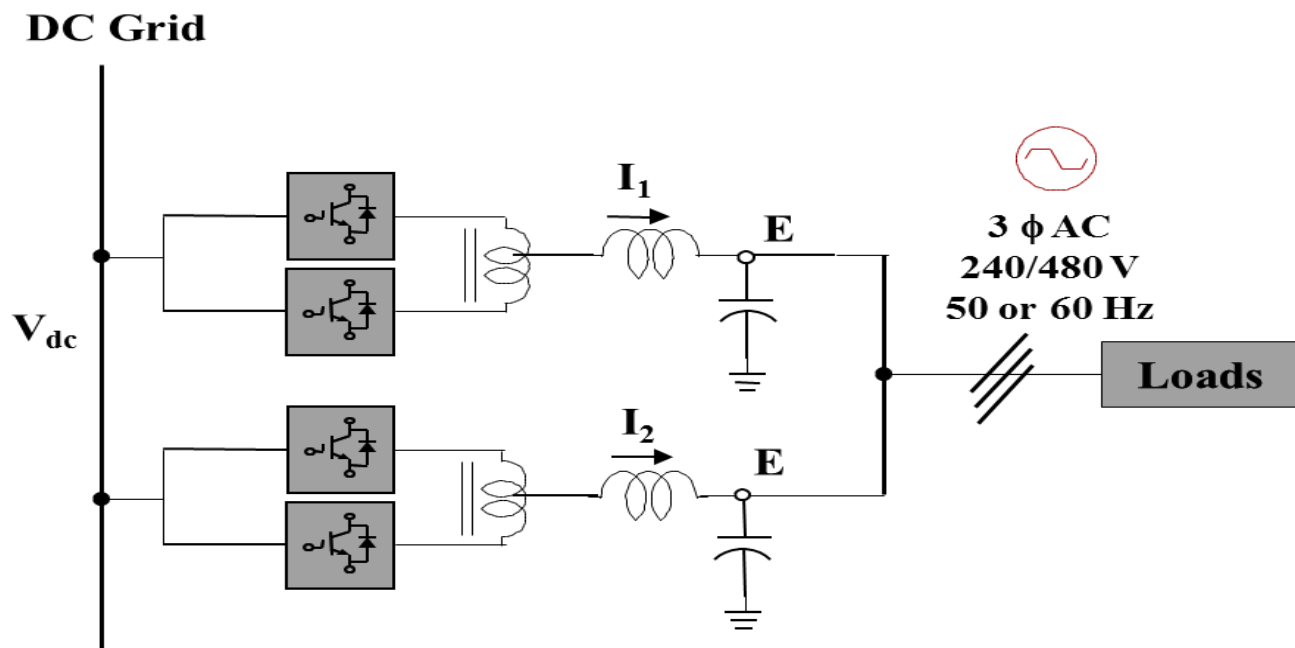

Figure 2.29: Block diagram of Paralleled-Connected Power Converters with a common DC grid in a Stand-alone AC System (Mwanza, 2014).

CHAPTER 3: METHODOLOGY

3.1 Introduction

This chapter gives an account of the methodology that was used in this research. The research started out with a power needs assessment to ascertain the amount of power expected from the hybrid generator, the next step was to assess the available resource for power generation, a simulation of the hybrid system was then done to predict the outcome and possible improvements, the next step was to design and manufacture the hybrid generator and lastly tests were done on the final design. The most part of the research dealt with the design and manufacture process of different components, but all other aspects are also described in the report.

3.2 Power Needs Assessment

The first step that was taken in the project was a power needs assessment of a typical rural community in regard to the use of cellular phones. The daily power needs of a typical cellular phone and a light bulb for use at night time, were assessed by way of literature review on the power consumption of typical household appliances, in this case the appliances of focus were four cellular phone chargers and one power conservative light bulb to be connected at any given time.

The power consumption of four cellular phones was found to be 12Wh and that of the conservative light bulb was found to be 15Wh this meant that the total minimum power to be produced by the energy system was the total of the two and that was calculated as 27Wh. The average power consumption of common household equipment is shown in table 4.1 of chapter 4.

3.3 Resource Assessment

The second step was to analyse weather data in regards to the typical average wind speeds and the average solar insolation for Zambia. The wind data was obtained by review of average results collected by the Meteorological department of Zambia over a period of 12 years, the average solar insolation results were also obtained from the Meteorological department historical data. The data was analysed and used to come up with an optimum design for the hybrid generator and its corresponding controls and energy storage devices.

The wind regime as seen in chapter 1 figure 1.1 was divided into three averages that is the low average, the medium average and the high average, this was necessary because it dictated when the wind turbine would kick in (start rotating), the average running speed and the highest speed of rotation that could be achieved. A further analysis of the wind data from the meteorological department of Zambia revealed that the average wind speed of the country was around 5m/s and this is shown in table 2.1 of chapter 2.

The solar insolation average figures over the course of the year were also obtained and studied as shown in figure 1.2 of chapter 2. The figures revealed that the average solar insolation for Zambia

was averaging between lows of 5KWh/m²/day and 7KWh/m²/day, this was according to literature obtained by the meteorological department of Zambia over the course of over 10 years.

3.4 Simulation of the Hybrid System

The third step of the research was to simulate the design using the wind speed data and the solar insolation data collected earlier and this was coupled with suitable energy storage and electronic controls which are further explained in chapter 4. The simulation was done using Homer software version 2.81, the simulation results showed that the hybrid was viable, but a few improvements had to be made on the actual design to achieve the desired results and this was done and incorporated in the final design of the hybrid. The software was also used to simulate the cost aspects of the generator.

The results of the simulation are shown in chapter 8 of the report and as can be seen from table 8.6 of the simulation results for 1 year, some months of the year fell below the required 27Wh for the hybrid to work as expected, this was improved by increasing the energy storage capacity of the hybrid system.

3.5 Design and Manufacture of the Hybrid System

The fourth step of the research project was to design the hybrid system, this was done using standard machine design procedures, CAD software and standard literature on design of wind turbines and solar power systems. The wind solar hybrid system was designed for optimum and efficient power output taking into account the costing aspects as well. The manufacturing was also done using standard manufacturing processes, equipment and tools.

The wind turbine generator blades were adapted from the NACA 2412 standard blade type as shown in chapter 4, the material used for the wind turbine blades was high density poly-ethylene plastic material, the method of manufacture is described further in the manufacturing chapter. The generator for the wind turbine was sized at a minimum of 27Wh of power but a 700Wh generator was used due to constraints on the purchasing of the generator size required, however this further increased the system power production.

The solar power system, electronic control system and battery energy storage system were sized and procured off the shelf for use on the hybrid system. The solar PV panel was sized at 31Wh of power at peak production while the electronic control system was sized to take a maximum peak power of 500Wh.

3.6 Testing of the Hybrid System

Lastly the wind/solar hybrid prototype system was tested to find out the extent to which it could be used, the actual tests were done at two sites. The first test site was a private residence in Olympia extension and the second test site was at the University of Zambia School of Engineering main building roof top.

The tests were carried out on the individual components of the hybrid system as described in the test chapter of the report, electrical outputs were measured using a multi-meter at hourly intervals for a period of one month, and the average figures were then compiled and plotted as shown in the results and discussion chapter.

CHAPTER 4: DESIGN OF HYBRID SYSTEM

4.1 Introduction

Chapter 4 looks at the design aspects of the wind/solar hybrid generator, it begins with a look at the components required for the system to successfully generate and combine the power outputs of the wind and solar generators which have completely different voltage characteristics. To come up with an optimal design of the hybrid, a simulation of the system was necessary, the simulation led to the design that was actually manufactured and assembled. The components of the hybrid were carefully selected, designed and/or manufactured. The simulation and test results based on the actual sizes of the components used are highlighted in the results and discussion chapter.

It is important to note that some of the components of the hybrid design also described in this chapter were sized, adapted and bought off the shelf as there was no need to manufacture components that are readily available on the market. Most of the design and manufacturing work on the system was done on the wind component, the solar, energy storage and electronic system was sized as required and purchased off the shelf.

4.2 Description of The Hybrid System

The hybrid system was comprised of a Solar PV system and a Wind turbine system that work simultaneously to generate electrical power for charging cell phones. The hybrid system incorporated other components that enabled it to combine the electrical outputs from the wind and solar generators, which have totally different characteristics. The full hybrid system components are summarised in Figure 4.1.

To begin the design phase of the hybrid it was first necessary to describe what we expected of the system. The hybrid energy system was designed to provide for electrical energy generation for a cell phone charging site of up to 4 cell phones and for use with other essential appliances or loads such as a light bulb for use during night time. Table 4.1 gives a summary of estimates of power consumption for various common household appliances.

As shown in table 4.2, the system was designed to charge up to 4 cell phones, this translated into a power demand of 12Wh and to power an energy saving light bulb which translated into a power demand of 15Wh, the total power demand expected from the whole system at peak was calculated as 27Wh. With the above power requirements each of the two energy sources was designed or selected to be able to produce a minimum amount of power more than the peak demand at any given time such that the system can run on one power source in the absence of the other.

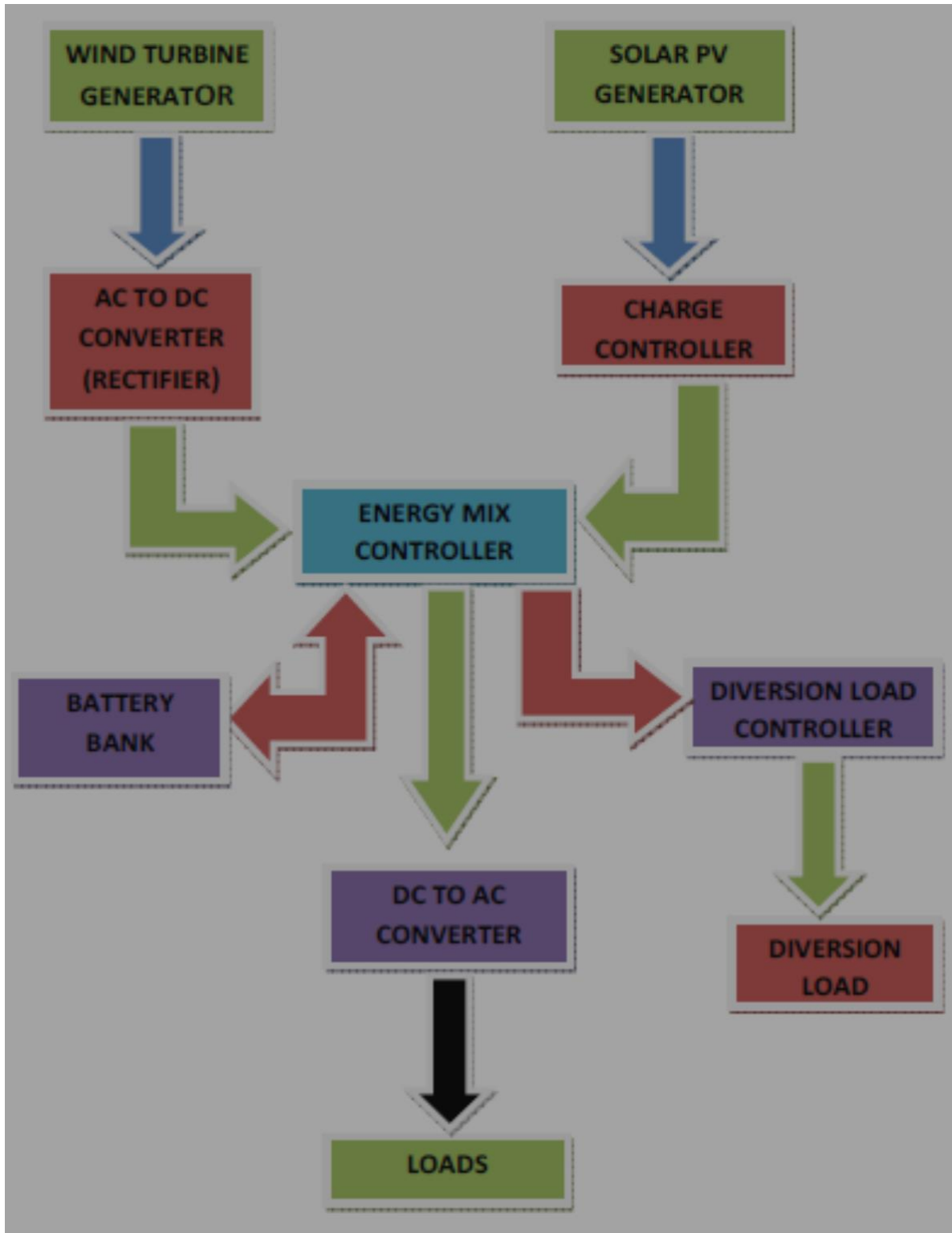

Figure 4.1: Block diagram of the full hybrid system.

Table 4.1: The table shows the energy consumption in watt-hour of some common household equipment (Masters, 2004).

CHARGERS			
CHARGER TYPE	NO LOAD (Watt-hour)	MAINTAINING CHARGE (Watt-hour)	CHARGING (Watt-hour)
Cordless phone charger	2.3	3.1	4.0
Cell phone charger	0.3	0.5	2.6
Digital camera charger	0.4	0.4	3.0
MP3 player charger	0.3	0.6	1.7
Toothbrush charger	1.7	1.7	1.7
Shaver charger	0.3	0.7	2.3
Battery charger	1.1	3.1	11.8
Cordless vacuum charger	0.8	3.7	4.7
LIGHT BULBS			
LIGHT PRODUCED (Lumens)	INCANDESCENT (Watt-hour)	CFL (Watt-hour)	
450	40	7	
800	60	15	
1100	75	20	
1600	100	23	
2600	150	35	

Table 4.2: The table shows the estimated power demand of various components and the peak demand of the system.

APPLIANCE	POWER DEMAND (Watts)	NUMBER	TOTAL POWER DEMAND (Watt-hour)
Cellular phone	3	4	12
Light bulbs	15	1	15
Peak Demand			27

4.3 Wind turbine generator

Generally wind turbines can be divided into 3 classes as shown in Table 4.3 (Mwanza, 2014).

Table 4.3: Classification of wind turbines (Mwanza, 2014).

SCALE	ROTOR DIAMETER (m)	POWER RATING (KW)
Micro	Less than 3	0.050 – 2
Small	3 - 12	2 – 4
Medium	12 – 45	40 – 999
large	More than 45	More than 1000

For this hybrid system we required a micro scale wind power generation system with a rotor of less than 3m diameter. Typical small wind generators have a rotor that is directly coupled to the generator which produces electricity either at 120/240 volt alternating current for direct domestic use or at 12/24 volt direct current for battery charging, larger machines generate three phase electricity.

Most small wind machines often have a tail vane which keeps the rotor orientated into the wind. Some wind machines have a tail vane which is designed for automatic furling (turning the machine out of the wind) at high wind speeds to prevent damage. Larger machines have pitch controlled blades (the angle at which the blades meet the wind is controlled) which achieve the same function (Mwanza, 2014).

The six important components of a small wind turbine system are as listed below.

1. The Generator.
2. The Blades and Blade Hub.
3. Mounting (the turbine body).
4. Tower (the mast assembly).
5. Battery(s).
6. Control System.

4.3.1 The Rotor Blades

Rotor blades are the most important component of the wind generator and they determine not only that the generator will work but also how much power it can produce. Blades can be designed and produced in many different ways, using different types of materials.

One cheap and easily obtainable material for blades is wood which can be successfully curved into all NACA profile blades discussed in the review of literature, the use of wood is suitable for use in Zambia and the material is readily available.

Another suitable way of producing the blades is by pressing metal sheet cut to size to the desired circular blade shape, but this requires specialized equipment for the pressing and may be too costly on startup.

A very interesting, easy, cheap and very quick way of producing effective wind turbine blades is by simply cutting the blade profile from a suitable diameter of PVC pipe depending on the desired angle of attack and twist required for the blades. By cutting PVC pipe lengthways and reshaping the leading and trailing edge by filing and sanding, a near perfect blade NACA profile blade can be achieved and the process is simple.

An eight inch pipe gives a suitable profile for an effective blade shape. The process of producing the blades is fairly easy and is as described in the manufacturing chapter. This type of blades were chosen because of these particular reasons.

Once the blades are cut to their rough shape, a file or sand paper can be used to smooth and shape the edges of PVC pipe quarter-pieces or the blades in this case. The leading edge should be rounded and the trailing edge should be sharp and straight. All three blades must be identical and of the same weight and this is critically important to balance the blades. The blades for our design were cut and shaped based on the NACA 2412 blade shape (Piggott, 2003).

The shape generation and design was done using the online software available at the website <http://airfoiltools.com>. The airfoil shape cross section generated using airfoil tools is as shown in Figure 4.2, the airfoil is tapered and twisted to achieve a tip speed ratio or TSR of 4. The calculations are shown in the subsequent equations.

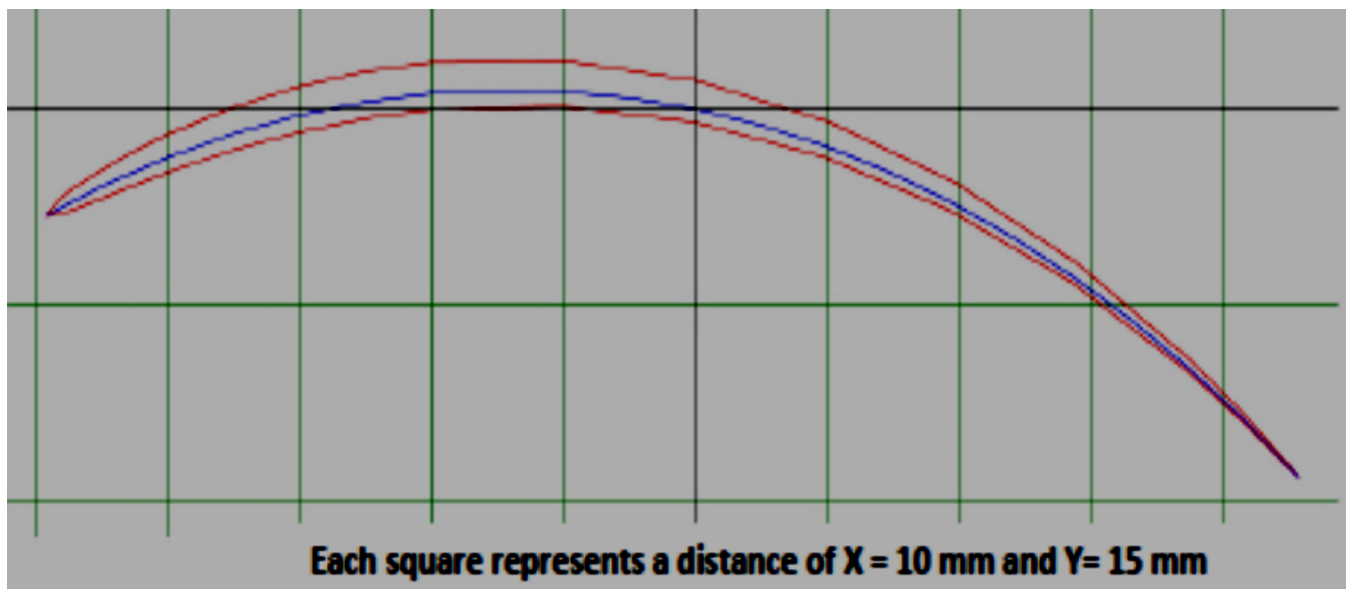

Figure 4.2: NACA 2412 blade shape with design parameters generated using airfoil tools, the parameters of the airfoil are represented by X in the horizontal direction and Y in the vertical direction.

The NACA 2412 parameters were adapted to the pipe section and where as shown in Table 4.4 below;

Table 4.4: Parameters of the adapted NACA 2412 airfoil generated using airfoil tools.

PARAMETER	
Airfoil type	2412
Chord length	100mm
Radius	100mm
Thickness	20%
Origin	50%
Angle of attack	8°

The calculations for the blades were as follows:-

Power in the wind is given as;

$$P = \frac{1}{8} \rho \pi D^2 V^3,$$

Equation 4.1

But by BETS limit only 59% of this can be harnessed and hence the power becomes;

$$P = \frac{2}{27} \rho \pi D^2 V^3,$$

Equation 4.2

Effectively the blades can only convert about 60 percent of this limit and hence the power at 60 percent is given as;

$$P = 0.17 D^2 V^3,$$

Equation 4.3

At a wind speed of 7m/s it will produce a power of about **84 watts**

Another important parameter is the tip speed ratio or TSR. The TSR is the ratio of the rotating blade tip to the free stream of wind, in some cases the tips of the blades move faster than the wind by a ratio of as much as ten times this takes them to very high speeds, resulting in noisy operation, rapid erosion of the blades edges and even breaking of the blades therefore a TSR of about seven or less is recommended. The TSR can be altered by changing the blade width towards the tip. For our blades the TSR was four after machining of the blades. It should be noted that the TSR can be varied by

altering the blade width towards the tips and so it is easy to get any desired TSR, but design considerations such as strength and power, must be taken into account.

The diameter of the turbine is 1.2m hence at a TSR of 4; the speed of rotation will be given as:

$$n = \frac{V*TSR*60}{2\pi R},$$

Equation 4.4

Hence at our average speed of 5m/s the speed of rotation will be calculated as:

$$n = 318 \text{ rpm},$$

The chord length of the blades is given as:

$$L_{chord} = \frac{4D}{B*TSR^2},$$

Equation 4.5

Hence the chord length was approximately taken as shown below after taking into account finishing processes:

$$L_{chord} = 0.1 \text{ m},$$

From the airfoil design using airfoil tools the following angles can therefore be derived as below;

$$\begin{aligned}\theta &= 8^\circ. \\ \varphi &= 2\theta = 16,\end{aligned}$$

Equation 4.6

Further to find the velocity components, we consider the vector diagram given in Figure 3.3 below;

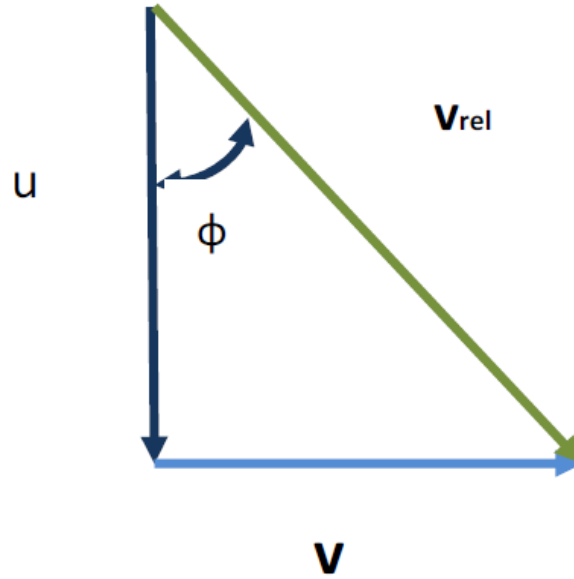

Figure 4.3: Velocity vector diagram.

The relative velocity V_{rel} is then calculated from the following equation:

$$V_{rel} = \frac{V}{\sin\phi},$$

Equation 4.7

Where: V is the wind velocity and $\phi = 20 = 16$.

The relative velocity is calculated as $V_{rel} = 18 \text{ m/s}$.

At an angle of attack of eight degrees the coefficient of lift and drag are taken from the graphs as:

$$C_L = 0.8 \quad \text{and} \quad C_D = 0.01$$

And the lift force F_L is given as;

$$F_L = C_L \frac{1}{2} \rho A V^2,$$

Equation 4.8

Which gives a value of $F_L = 700\text{N}$

The drag force is given as below at the same angle of attack as;

$$F_D = C_D \frac{1}{2} \rho A V^2 ,$$

Equation 4.9

Which gives an approximate value of $F_D = 9\text{N}$

Taking the angles between the tangential and axial velocities and, between the lift and resultant force vectors as $\epsilon_s = 26$ and $Y = 18$ degrees respectively. We then calculate the torque Q and power P as shown in the following equations;

$$Q = \frac{1}{\cos^2 \epsilon_s \cos Y} \rho C_L b V^2 (R_1^2 - R_0^2) \cos(\epsilon_s + Y) ,$$

Equation 4.10

Which gives an approximate torque of $Q = 6 \text{ Nm}$ and from the equation:

$$P = \frac{2\pi Q n}{60} ,$$

Equation 4.11

And the power that will be generated will be approximately:

$$P = 166$$

4.3.2 The Generator

A number of options have been outlined in the literature review and in this chapter we shall only discuss the generator that was chosen for this design.

Generally wind turbines run at low speeds and thus the generator should offer the least amount of resistance so as to allow the generator system to cut in at very low wind speeds. There has been a lot of innovation in this area and there are some generators that have been developed without cores or coreless generators, this eliminates the magnetic attraction between core and magnetic field and hence the generator faces little opposition while it is spinning or attempting to spin.

The generator type chosen based on availability and purchased on e-bay is the Victory permanent magnet alternator (PMA) 12 volt model with DC output and a heavy duty case.

It has a seven magnet rotor and can generate up to 700Wh (Missouri Wind, 2014).

Further specifications of the PMA are given below.

- The generator uses Rare Earth Neodymium Magnets N45 magnets.
- The coils are hand wound for the Stator.
- The Generator is computer balanced.
- It reaches over 12V below 150rpm.
- Adapted for 12 Volt battery charging.
- Bi-Rotational.
- Anti-cogging low start-up speeds.
- Ideal for low wind start-up.
- Hand built with 100 percent brand new components.
- Can be used for battery charging and/or grid tie feed inverters.
- Can be used with wind turbines nine blades or less, vertical axis wind turbines and hydro turbines.

The voltage and current characteristic of the generator are given in Table 4.5, while Figure 4.4 shows a schematic drawing of the generator as designed by the manufacturer

Table 4.5: Characteristics of the generator at different speeds (Missouri Wind, 2014).

SPEED (RPM)	VOLTAGE (VOLTS)	CURRENT (AMPS)
150	12	1.5
300	25	4
500	43	7
750	60	10
1000	70	11

4.3.3 The Turbine Body And Mounting

The turbine body is fairly simple in design and it is up to one to choose a material for this purpose. Various types of materials can be used, wood has been used before and it offers high strength at a very cheap price and the material is readily available. Steel and aluminium offer very good strength as well but the prices may be too high as compared to wood. For this design steel tubes were used for the frame construction, this offered high strength as well as light weight to keep the construction as simple as possible. 25*25mm steel tubes and 5mm steel plate were used for the construction of the main body.

The mounting mast was also kept as simple as possible and for this purpose a 100 mm pipe of length 10m was used. The assembly and the respective components are shown in Figure 4.5 while the description of the individual components is summarised in Table 4.6.

Table 4.7 outlines all the components and the material used for each component, it must again be noted that the components of the solar system were purchased off the shelf, the main component of

the solar system was the solar PV panel itself while the electronic components include the power electronic converters and the charge mix controller which comes fully fitted with a dump load and relay switch.

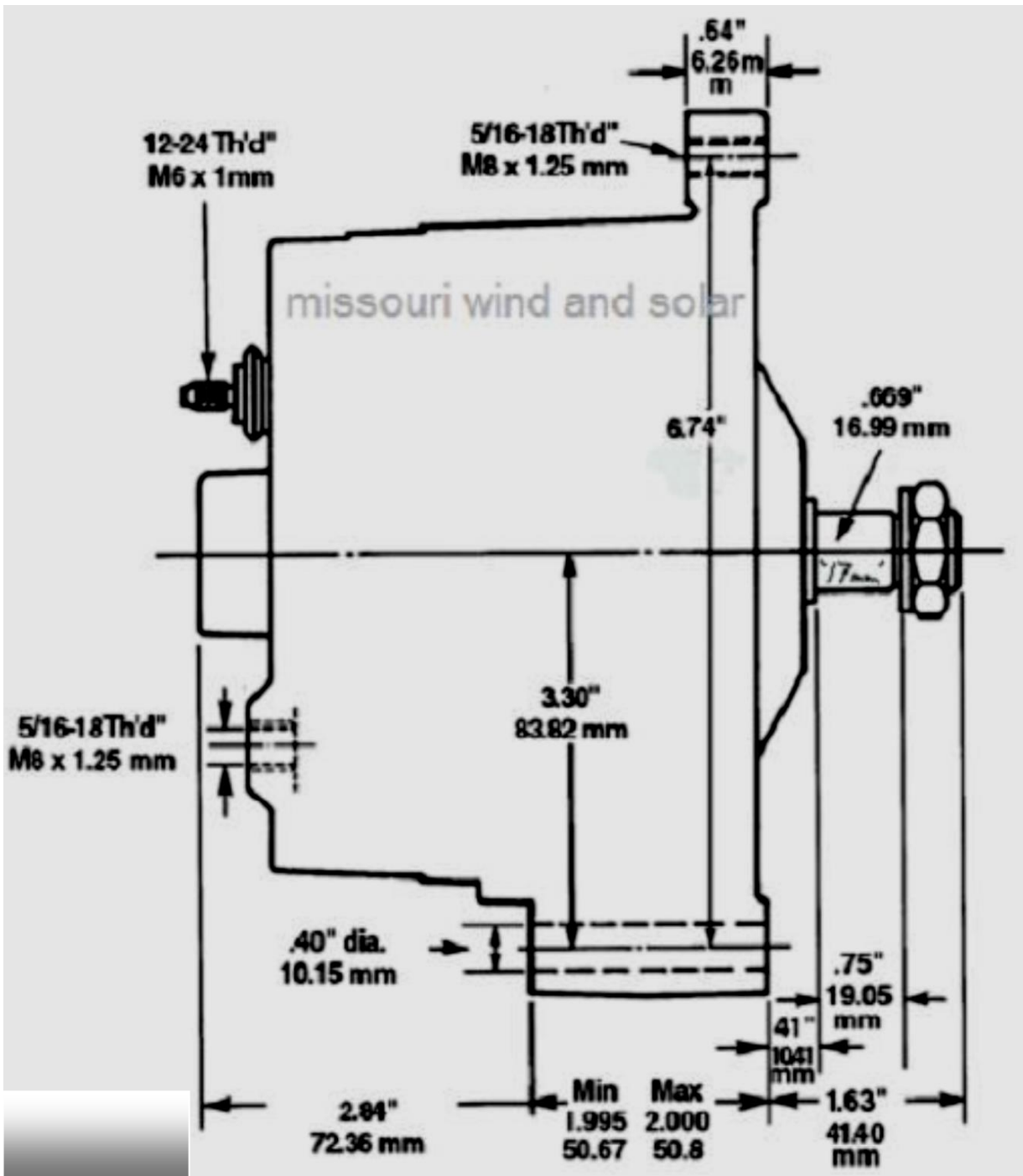

Figure 4.4: Schematic drawing of the Victory permanent magnet generator (Missouri Wind, 2015).

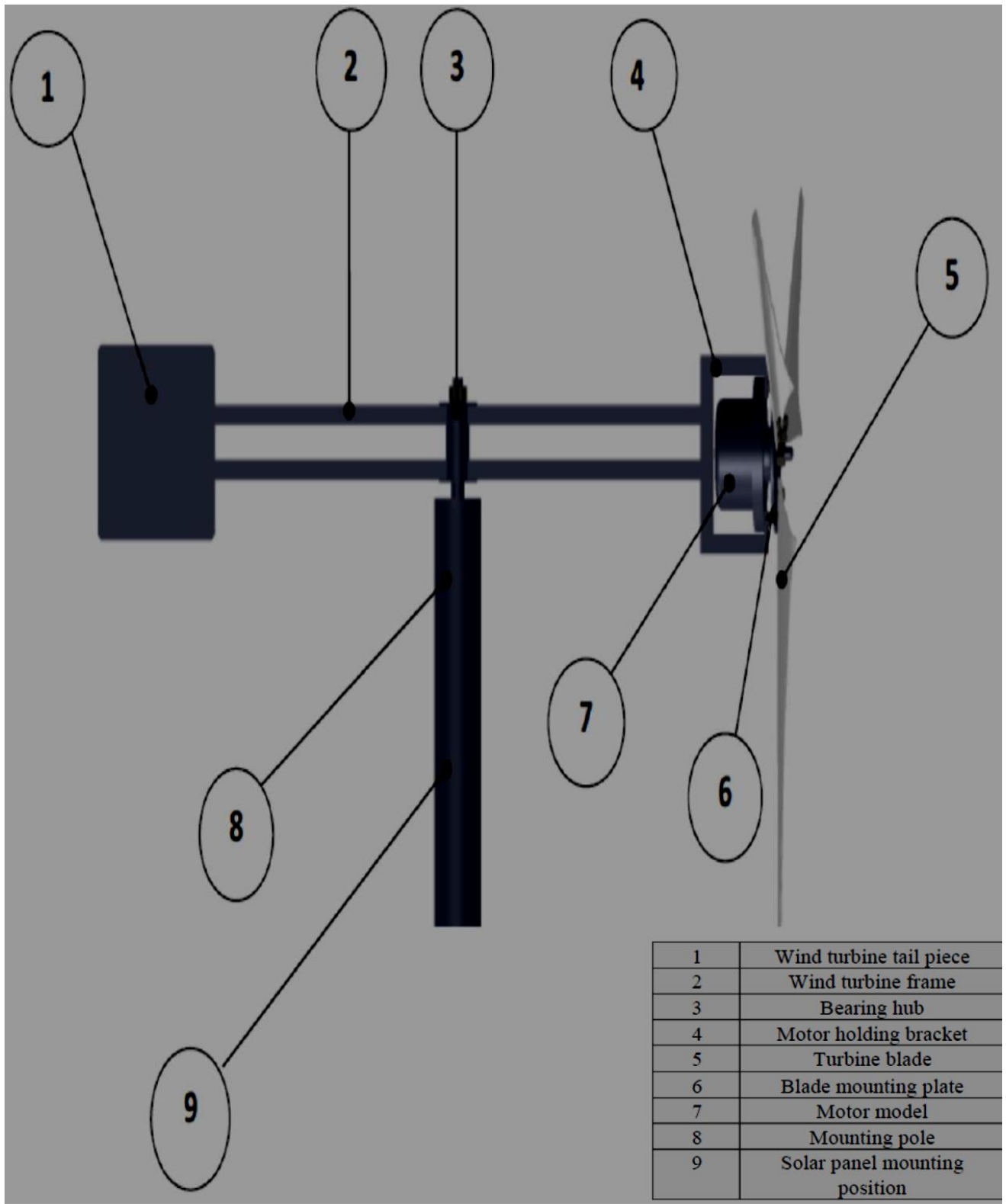

Figure 4.5: Wind generator system assembly.

4.4 Setting Up The PV Panel For Power Generation

To successfully setup the 31 watts solar panel for solar power generation a rule of thumb can be used for the first step and it states that if you're in the:-

- Northern hemisphere: face the collector South
- Southern hemisphere: face the collector North

The solar collector can then be tilted at an angle equal to the local latitude; this method can be used for good annual performance.

To find the optimum tilt angle however a few calculations need to be done first we note that the altitude angle at solar noon is given by equation 2.4.

$$\beta_N = 90^\circ - L + \delta,$$

For a panel to be installed in Lusaka with latitude of $L=15.4$ degrees the altitude angle of the sun at solar noon on first July is calculated as:

$$n = 182, L = 15.4^\circ, \delta = 23.12, \beta_N = 97.72^\circ$$

For a collector to collect the optimum amount of solar energy we must first face the collector north and the raise it to a tilt angle T calculated below from equation 2.6

$$T = \beta_N - 90 = 7.72^\circ,$$

It must be noted though that this angle will be changing depending on the day number; a tilt angle equal to the latitude of 15.4° for Lusaka is acceptable for practical purposes. The solar panel is placed at a suitable height along the 10m pole that also holds the wind turbine generator.

4.5 Outline of All the Components and Technical Specifications

Table 4.7 summarises all the materials and components used for the hybrid, it must again be noted that the components of the solar system were purchased off the shelf, the main component of the solar system was the solar PV panel itself while the electronic components include the power electronic converters and the charge mix controller which comes fully fitted with a dump load and relay switch, the energy storage system was also purchased off the shelf.

Table 4.6: Summary of system components, notes and specifications.

COMPONENT	NUMBER REQUIRED	NOTES	TECHNICAL SPECIFICATIONS
Turbine Blades	3	The turbine blades were manufactured from 8” PVC pipe of 20mm thickness according to the NACA 2412 blade specifications.	The NACA type 2412 blades are of 600mm length and 100mm chord length.
Rectifier for wind turbine generator	1 in single phase or 2 in case of 3 phase generator	The rectifier was needed for converting the AC power to DC produced from the wind turbine	A rating of 50 amps for the rectifier was chosen to accommodate high temperatures.
Solar PV panel	1	The most common type of solar panels available locally is the crystalline silicon type and this is what was used.	A 31 watts solar PV panel was be used
Energy mix controller	1	The energy mix controller was needed to enable the combination of the solar and wind system which have different voltage characteristics	The energy mix controller was rated to cater for the wind and solar system in combination and the rating that was used was 500W.
Inverter/charger	1	The inverter was needed to convert the DC voltage to AC to supply the cell phones	The inverter was sized for 12V and 500W
Deep cycle Battery	1	There are various types of deep cycle, they range in size and performance depending on the type, this was needed for energy storage purposes	A 12V, 21Ah deep cycle battery Nickel Cadmium battery was used for this purpose
Wind turbine generator	1	Various types of low wind speed permanent magnet generators are available on e-bay and can be purchased as required	A 12V PMA with a power output of 700W was used for this purpose.
Bearing hub	3	Bearing and bearing HUBs can be purchased and sized according to specifications	For this wind generator a 200mm diameter bicycle crank was used as a hub

			for the wind turbine generator with a shaft size of 17mm
10mm Metallic flat plate	1	Metallic flat plates are available for purchase in hardware stores	A 10mm flat was used for fabricating the frame of the small wind turbine
5mm Metallic flat plate	1	Metallic flat plates are available for purchase in hardware stores	A 5mm flat was used for fabricating the frame of the small wind turbine
1mm metallic flat plate	1	Metallic flat plates are available for purchase in hardware stores	A 1mm flat was used for fabricating the frame of the small wind turbine
M10 Bolts and nuts	20	The bolts are to be used as fasteners on the wind turbine	M10 Bolts and nuts for fastening different points of the wind generator
M12 Mounting shaft (fine thread)	1	The shafts are supplied with the bicycle bearing hub but depending on the mount style the shaft may be too short, but they can be machined.	M12 metric fine thread mounting shaft (1.25mm thread)
Mounting pole	1	The mounting pole holds the wind turbine in the wind and it also holds the solar PV panel	The mounting pole is made from 4mm thick steel pipe and it stands 10m above ground
Plastic stabilizing cables	3	The plastic stabilizing cables hold the mounting pole in place and upright	These mounting cables are be 15m long
Frame square tube	1	The frame square tubes are used for fabrication of the turbine frame, these are cheap and readily available in hardware stores	Approximately 6m of 25mm*25mm square tube is required to fabricate the turbine frame
Angle iron	1	The angle iron is required fabrication of the frame	Approximately 2m of 25mm*25mm square tube is required to fabricate the turbine frame

CHAPTER 5: MANUFACTURING AND ASSEMBLY OF THE HYBRID

5.1 Introduction

This chapter outlines the manufacturing aspects of the research project. Some of the components of this research project were bought off the shelf although they can also be manufactured, this was advantageous because these have already been tried and tested and so eliminated laborious research on too many individual components but rather the system as a whole. As in the design chapter we will start by looking at the manufacturing aspects of the wind turbine generator system, the engineering drawings of the particular components have been attached in Appendix 1.

5.2 Manufacturing of the wind turbine system

The components of the wind turbine system are as listed below;

1. The Generator
2. The Blades and Blade Hub
3. Mounting (the turbine body)
4. Tower (the mast assembly)
5. Battery(s)
6. Control System

We will begin by describing the manufacturing process of the turbine blades. The first step in the manufacturing process was to find the material for the blades and in this case the material was 200mm diameter, 20mm thick PVC pipe.

To begin the manufacturing process a length of pipe equal to the calculated length of the blades in this case the length is 0.6m was then cut, we then cut the pipe lengthwise into 4 quarters and this gives the pieces that four blades can be cut out from. Each blade was then curved out from the four quarters of the pipe.

The Figure 5.1 illustrates the PVC pipe to be cut into 4 quarters for the blades, the thickness of the pipe to be used for the blades depends mostly on the design specifications, size of the blades and also the amount of torque required on the generator for the blades to cut in.

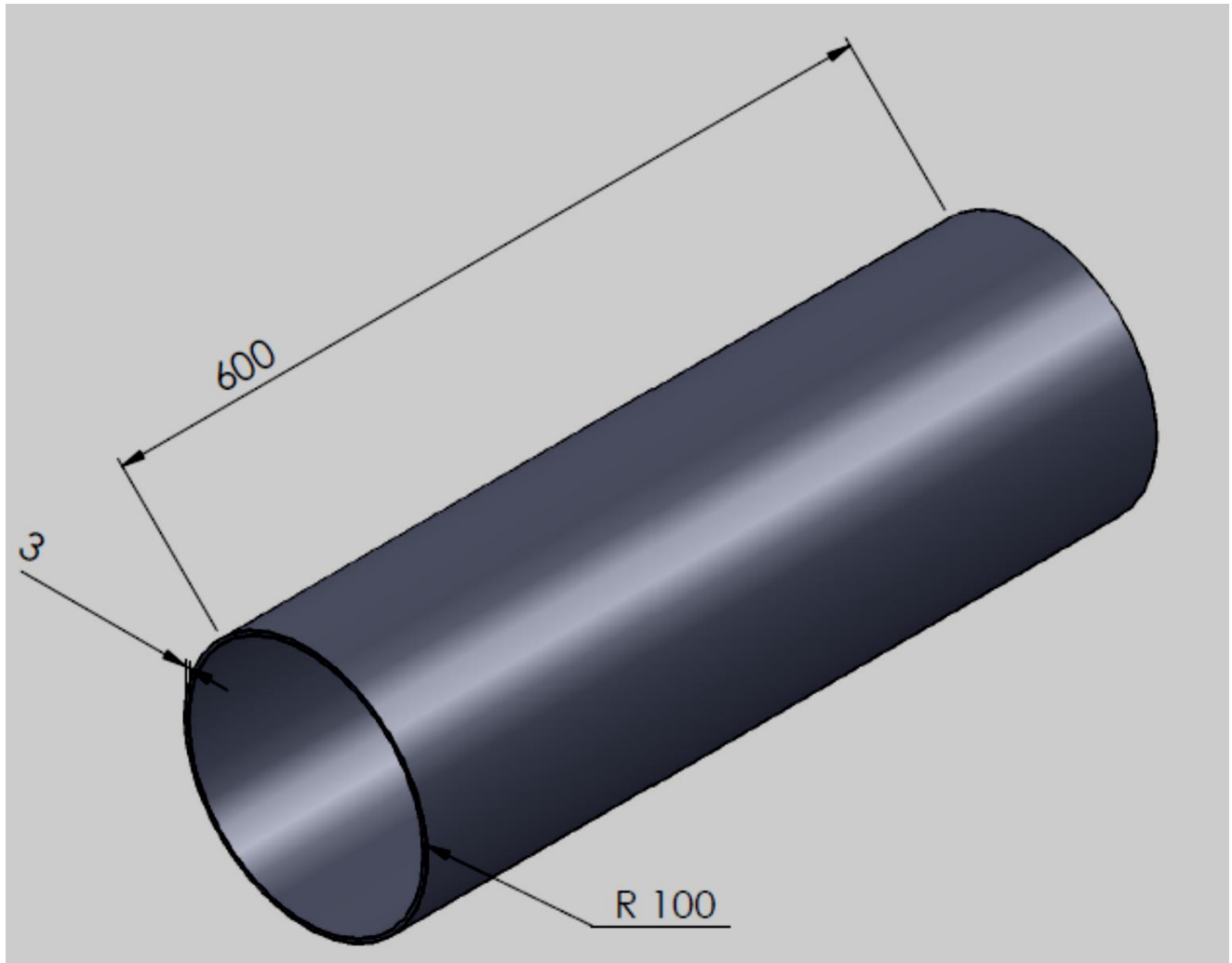

Figure 5.1: Illustration of 200mm pipe for the turbine blades.

The pipe is cut into 4 quarters around its circumference; the cutting is done lengthwise into four pieces as shown in the Figure 5.2. This is done by fixing the pipe cut to length on a cutting bench and then cutting lengthwise first into 2 halves and then the halves into quarters. Alternatively this can be done using hand cutting tools such as an angle grinder and the measurements done with a 90 measuring square and flexible measuring tape, this is a much more difficult process and requires high levels of skill. Once this is done, the blade can then be cut into shape as shown on Drawing 1 in Appendix 1.

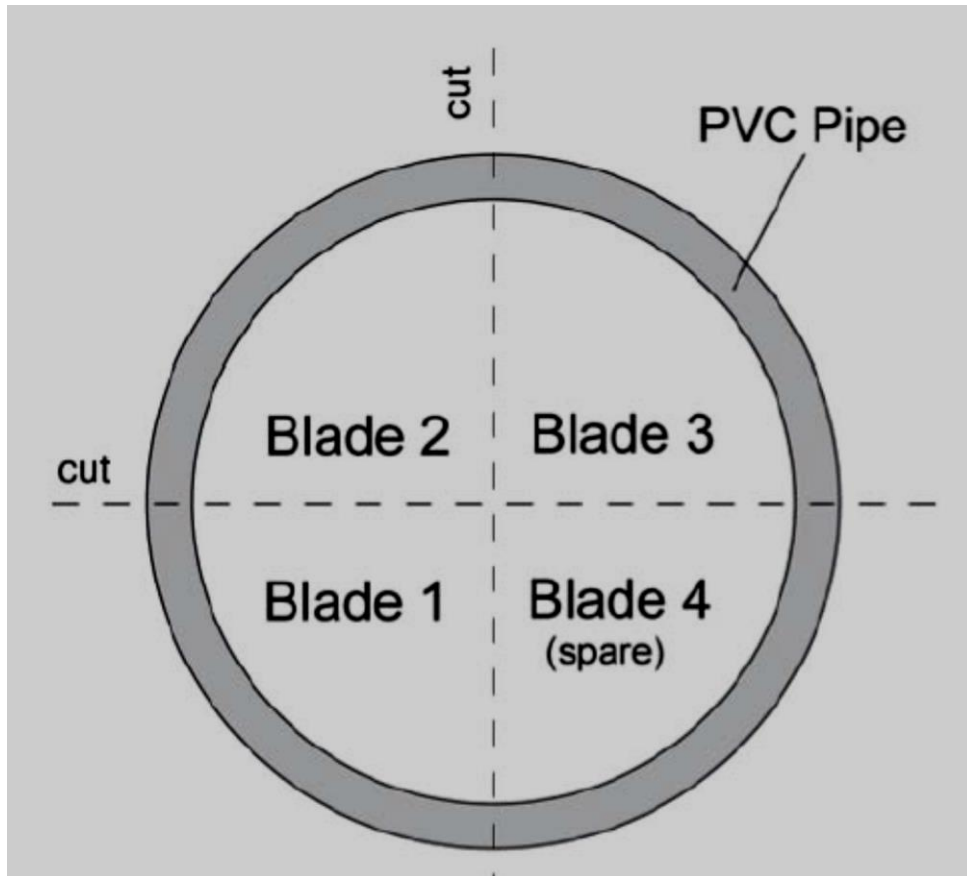

Figure 5.2: Cutting of the blades.

When joining the points of the measurements, masking tape can be used to mark the points so as to get a straight line as it wraps around the curvature of the pipe. After the blades are cut they can then be assembled to the blade hub. The cutting parameters are as shown in the Table 5.1 below.

Table 5.1: NACA 2412 generated specifications (Airfoil Tools, 2015)

Name	NACA 2412
Chord (mm)	100
Radius (mm)	100
Thickness (%)	20
Origin (%)	50
Pitch (degrees)	8

After the blades have been attached to the hub they need to be balanced and the balancing process is as follows;

The balancing process is done in five steps as outlined below, this has to be done very carefully as it affects the performance of the wind turbine (Piggott, 2003)

1. Each of the three blades is marked with a number say one to three.
2. The blades are mounted onto the hub and coupled to the generator.
3. Spin the blades a couple of times and let the blades come to a stop.
4. For each spin, the blade number that stops at the bottom is documented. If the same blade ends up at the bottom each time, it is an indication that it is the heavier blade and could affect the efficiency of the wind turbine.
5. If a blade is found to be heavy, which is usually the case; the blade can be sanded down further at the curved edge. This process has to be repeated several times to achieve a perfect balance.

5.3 Manufacture of Other Components of the Hybrid System

The manufacture of the other components is summarised in Table 5.2 below;

Table 5.2: Summary of the Manufacture of different components.

COMPONENT	NUMBER REQUIRED	MANUFACTURE PROCESS	EQUIPMENT/TOOLS REQUIRED
Turbine Blades	3	Cutting or milling of blades and sanding of sharp edges	<ol style="list-style-type: none"> 1. Mounted cutting blade or hand cutting tools can be used 2. A belt sander or sand paper can be used for smoothing the edges.
Rectifier for wind turbine	1 for single phase or 2 in case of 3 phase generator	Off the shelf	none
Solar PV panel	1	Off the shelf	None required
DC charge controller	2	Off the shelf	None required
Energy mix controller	1	Off the shelf	None required
Diversion load controller and load	1	Off the shelf	None required
Inverter/charger	1	Off the shelf	None required

Table 5.2: Summary of the Manufacture of different components (cont'd).

Deep cycle Battery	1	Off the shelf	None required
Wind turbine generator	1	Off the shelf	None required
Bearing hub	3	Off the shelf	None required
10mm Metallic flat plate	1	<ol style="list-style-type: none"> 1. Metallic flat plates are available for purchase in hardware stores. 2. The plate is further milled to shape or cut to shape using an angle grinder 	<ul style="list-style-type: none"> - A milling machine is suitable for this purpose - In case of homemade preference an angle grinder can be used
5mm Metallic flat plate	1	<ol style="list-style-type: none"> 1. Metallic flat plates are available for purchase in hardware stores. 2. The plate is further milled to shape or cut to shape using an angle grinder 	<ul style="list-style-type: none"> - A milling machine is suitable for this purpose - In case of homemade preference an angle grinder can be used
1mm metallic flat plate	1	<ol style="list-style-type: none"> 1. Metallic flat plates are available for purchase in hardware stores 	<ul style="list-style-type: none"> - A milling machine is suitable for this purpose - In case of homemade preference an angle grinder can be used
M10 Bolts and nuts	20	None required	<ul style="list-style-type: none"> - A hand cutting tool such as a Hack Saw or angle grinder to reduce the length of the bolts when required
M12 Mounting shaft (fine thread)	1	None required	<ul style="list-style-type: none"> - The threaded shaft is supplied with the bearing hub, however if a longer shaft is required it can be machined on a lathe machine

Table 5.2: Summary of the Manufacture of different components (cont'd).

Mounting pole	1	None required	- The mounting poles are supplied in 6m length and can be joined by welding if a longer length is required.
Steel stabilizing cables	3	None required	None required
Frame square tube	1	1. The frame square tubes are used for fabrication of the turbine frame; these are cut to length and then welded to the required shape.	- For this purpose an angle grinder is required for cutting and a welding machine for joining
Angle iron	1	- The angle iron is required fabrication of the frame, it is cut to length and welded in place	For this purpose an angle grinder is required for cutting and a welding

CHAPTER 6: COST OF THE HYBRID SYSTEM

6.1 Introduction

This chapter deals with the cost aspects of the hybrid system, the annualized costs are simulated using Homer 2 version 2.81 Software. The chapter also shows the actual costs of the hybrid system and these are the costs that were used for the simulation. The chapter goes further to analyse the levelized costs of energy and operation costs associated with the hybrid.

The levelized cost of electricity (LCOE), is a very important parameter used when comparing different energy sources, it is defined as the net present value of the unit-cost of electricity over the lifetime of a generating asset. It is often taken as a proxy for the average price that the generating asset must receive in a market to break even over its lifetime. It is a first-order economic assessment of the cost competitiveness of an electricity-generating system that incorporates all costs over its lifetime. The costs include, the initial investment, operations and maintenance, cost of fuel and the cost of capital (international energy agency, 2005)

6.2 Costs and Simulation Of Hybrid System Design Using Homer 2 version 2.81 Software

A simulation of the full hybrid using Homer 2 simulation software version 2.81 and the results are as outlined in this chapter. Table 6.1 below summarizes the components and their specifications.

Table 6.1: The Hybrid system architecture.

#	COMPONENT	SPECIFICATIONS
1	PV Panel	0.031 KW
2	Wind turbine	0.700 KW
3	Battery	12 V, 21AH
4	Inverter	0.5KW
5	Rectifier	0.5 KW

Table 6.2 below summarizes the cost aspects of the hybrid system in United States dollars, this was necessary because the US dollar is a more stable currency as compared to the Zambian Kwacha, the prices used in the simulation were the actual prices of the components.

Table 6.2: Cost summary report.

Total net present cost	\$ 2,488
Levelized cost of energy	\$1.555/KWh
Operation cost	\$175/yr

Further a cash flow summary was done using the Homer software and the results are shown in Figure 6.1, the component Hoppecke described here was the make of battery that was used for the

simulation. As seen from the cash flow summary the biggest cost is the operation and maintenance cost on the wind turbine and the electronic converter system, the other component have zero to negligible operation and maintenance costs. Further it can also be observed that the other big cost is the capital cost which was the actual cost of the components used in the research work, fuel costs in this case are zero. Table 6.3 shows the net present costs of the individual components.

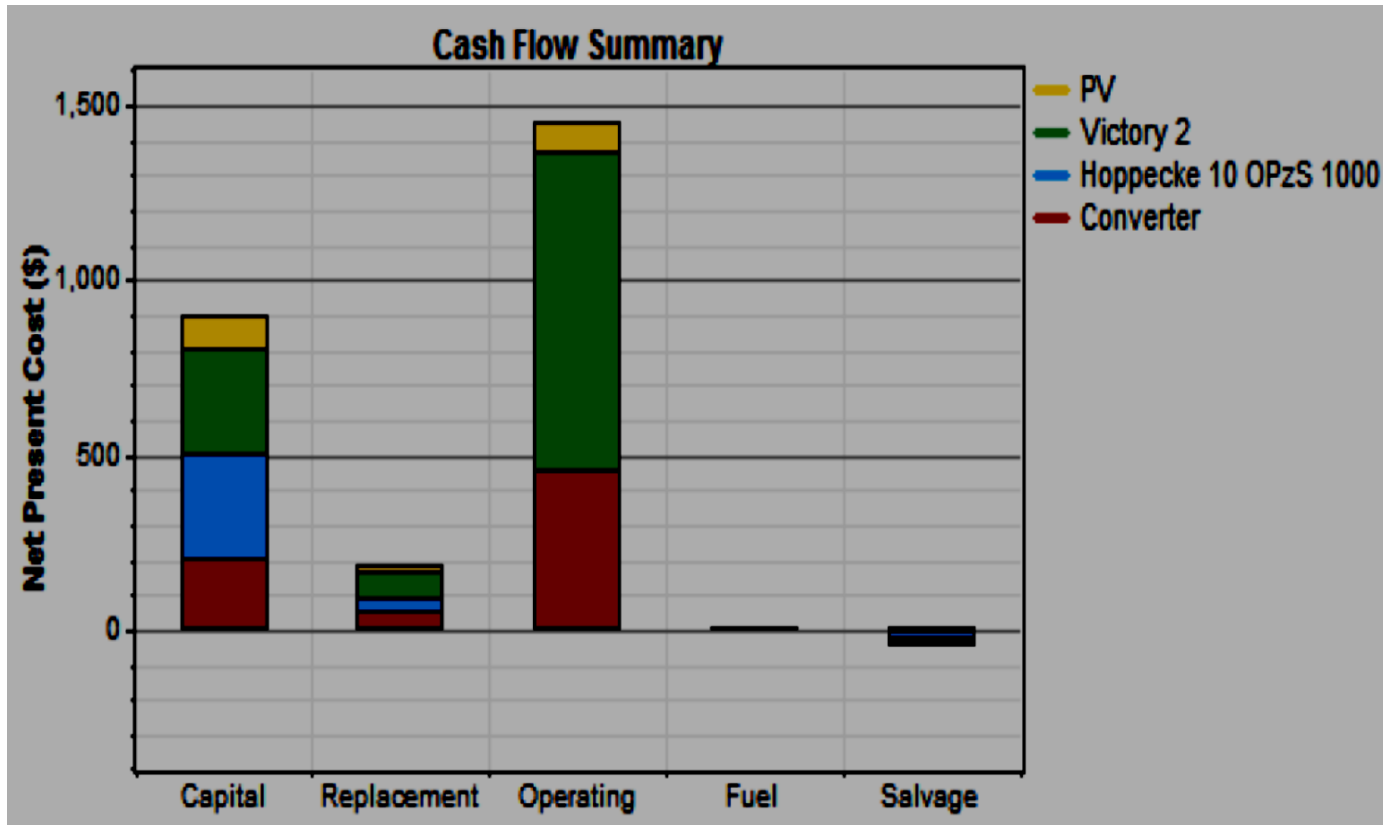

Figure 6.1: Cash flow summary of the hybrid system.

Table 6.3: Net present costs.

COMPONENT	CAPITAL (\$)	REPLACEMENT (\$)	O&M (\$)	FUEL (\$)	SALVAGE (&)	TOTAL (\$)
PV	100	15	91	0	-7	199
Victory	300	72	908	0	-9	1270
Battery	300	45	0	0	-21	324
Converter	200	48	454	0	-6	696
Full System	900	179	1452	0	-43	2488

The software was also used to simulate the annualized costs and the results were as shown in Table 6.4. Further the simulation results of a cash flow analysis were also obtained and were as shown in

figure 6.2. The cash flow analysis was done for a life period of 25 years. Table 6.5 shows the actual costs of all the components used on the hybrid system design.

Table 6.4: Annualized costs of the hybrid system.

COMPONENT	CAPITAL	REPLACEMENT	O&M	FUEL	SALVAGE	TOTAL
Solar PV panel	11	2	10	0	-1	22
Victory permanent magnet generator	33	8	100	0	-1	140
12V 21AH Battery	33	5	0	0	-2	36
Converter	22	5	50	0	-1	77
Full system	99	20	160	0	-5	274

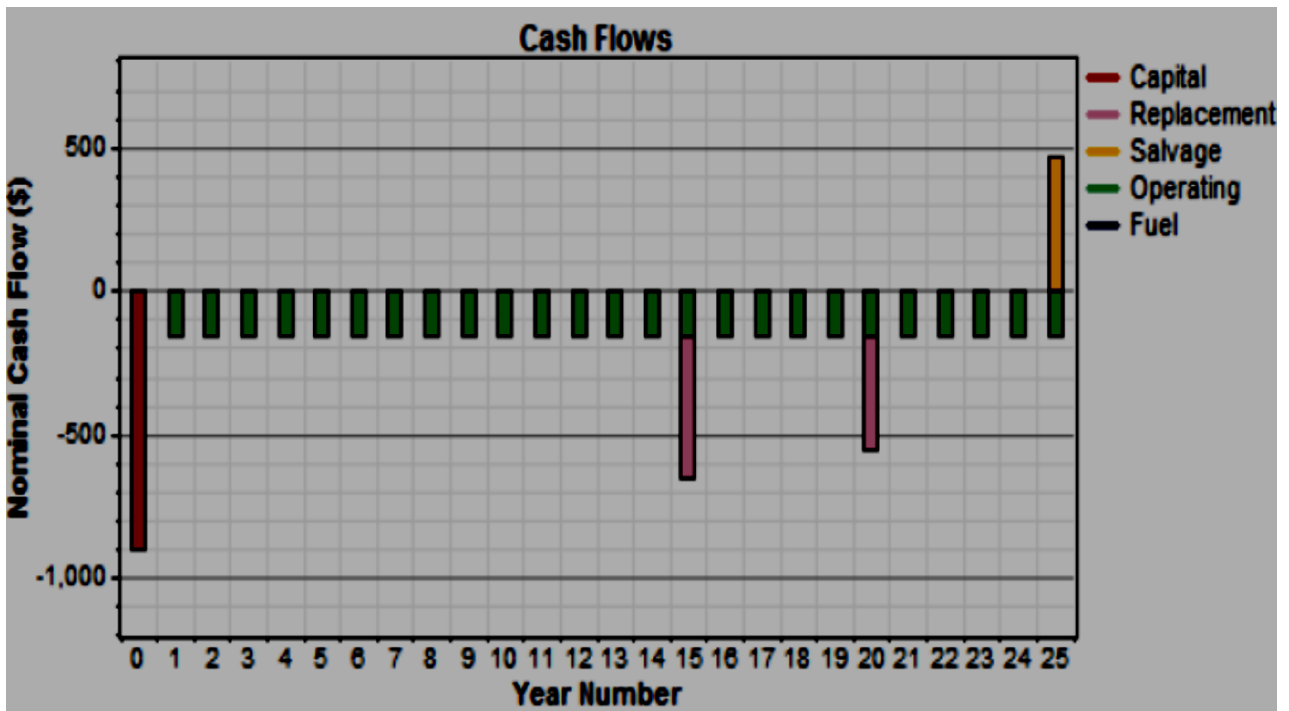

Figure 6.2: cash flow simulation.

Table 6.5: Actual costs of all hybrid components.

COMPONENT	NUMBER REQUIRED	WHERE TO PURCHASE	COST IN KWACHA (USD)
Turbine Blades	3	Manufactured from 20mm PVC pipe which is available locally	600
Rectifier for wind turbine	1	Locally	100
Solar PV panel	1	Locally	800
DC charge controller	2	Locally	250
Energy mix controller	1	Not available locally (available on e-bay)	1850
Diversion load and controller	1	Not available locally (available on e-bay)	600
Inverter/charger	1	Locally	700
Deep cycle Battery	1	Locally	1000
Wind turbine generator	1	Not available locally (available on e-bay)	2250
Bearing hub	3	Locally	300
10mm Metallic flat plate	1	Locally	150
5mm Metallic flat plate	1	Locally	150
1mm metallic flat plate	1	Locally	100
M10 Bolts and nuts	20	Locally	100
M12 Mounting shaft (fine thread)	1	Machined Locally	100
4" Mounting pole	1	Locally	1000
Steel stabilizing cables	3	Locally	180
Frame square tube	1	Locally	120
Angle iron	1	Locally	100
Metallic straps	10	Locally	180
TOTAL COST			10630 (1518.6)

CHAPTER 7: TESTING OF THE HYBRID GENERATOR

7.6 Introduction

This chapter deals with the tests that were done on the wind/solar hybrid generator. The chapter starts with a look at the tests done on the solar component, the wind component and finally the full hybrid system with the control system and/or battery storage connected. The solar and wind generators were tested individually and as a hybrid with the electronic control and battery storage fully connected.

7.7 Testing of the Solar Component of the Hybrid System

The solar component of the hybrid generator was tested first and the results are highlighted in chapter 8. The solar component of the generator was tested over a daily twelve hour period from 06:00 hours in the morning to 18:00 hours in the evening over a four week period. The solar component was further tested with 12V battery storage connected through an electronic power conversion and control system and it was able to charge the 12 battery. Figure 7.1 illustrates the connection of the solar system the components are also described. The electronic power conversion and control system was able to control the system voltage by dumping excess power to an externally connected dump load.

7.8 Testing of the Wind Component of the Hybrid System

The wind component of the hybrid generator was also tested independently and the results are highlighted in chapter 8. The wind generator component, just like the solar component of the was tested over a daily twelve hour period from 06:00 hours in the morning to 18:00 hours in the evening over a four week period. Further the wind turbine was tested with 12V battery storage connected through an electronic conversion and control system as shown in Figure 7.2, the turbine was able to charge the 12 battery. The electronic power conversion and control system was able to control the erratic system voltage produced by the wind turbine by dumping excess power to an externally connected system dump load.

7.9 Testing of the Battery Component of the Hybrid System

The battery or energy storage component of the hybrid device was tested and the results are shown in chapter 8 of the report. The battery as shown in chapter 8 was able ensure stable and almost uninterrupted power supply to the whole system even when both generators were off peak. The battery just like the wind and solar components was tested over a daily twelve hour period from 06:00 hours in the morning to 18:00 hours in the evening over a four week period. Further the battery was tested with the full system connected as shown in figure 7.3.

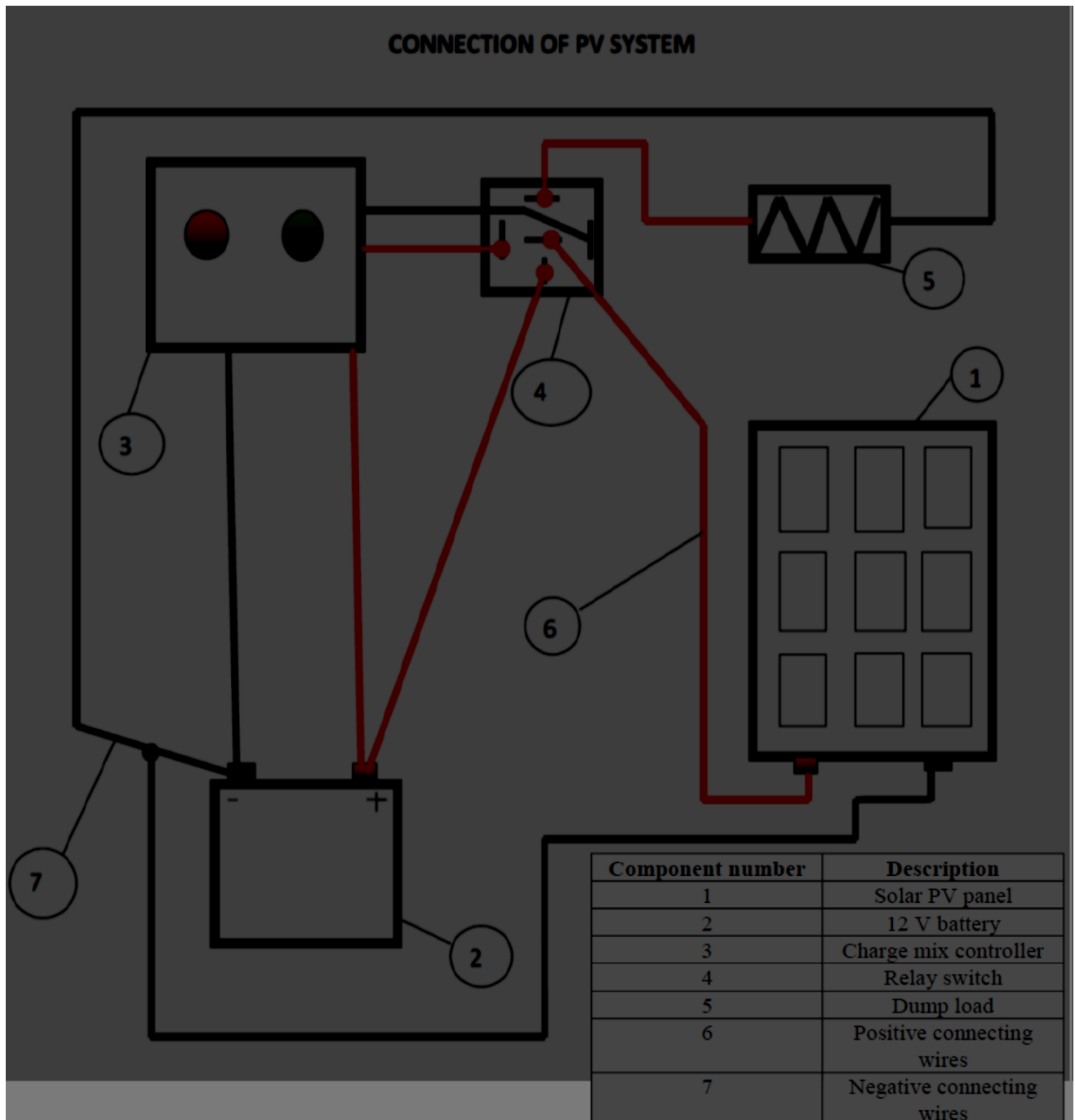

Figure 7.1: Connection of the PV panel.

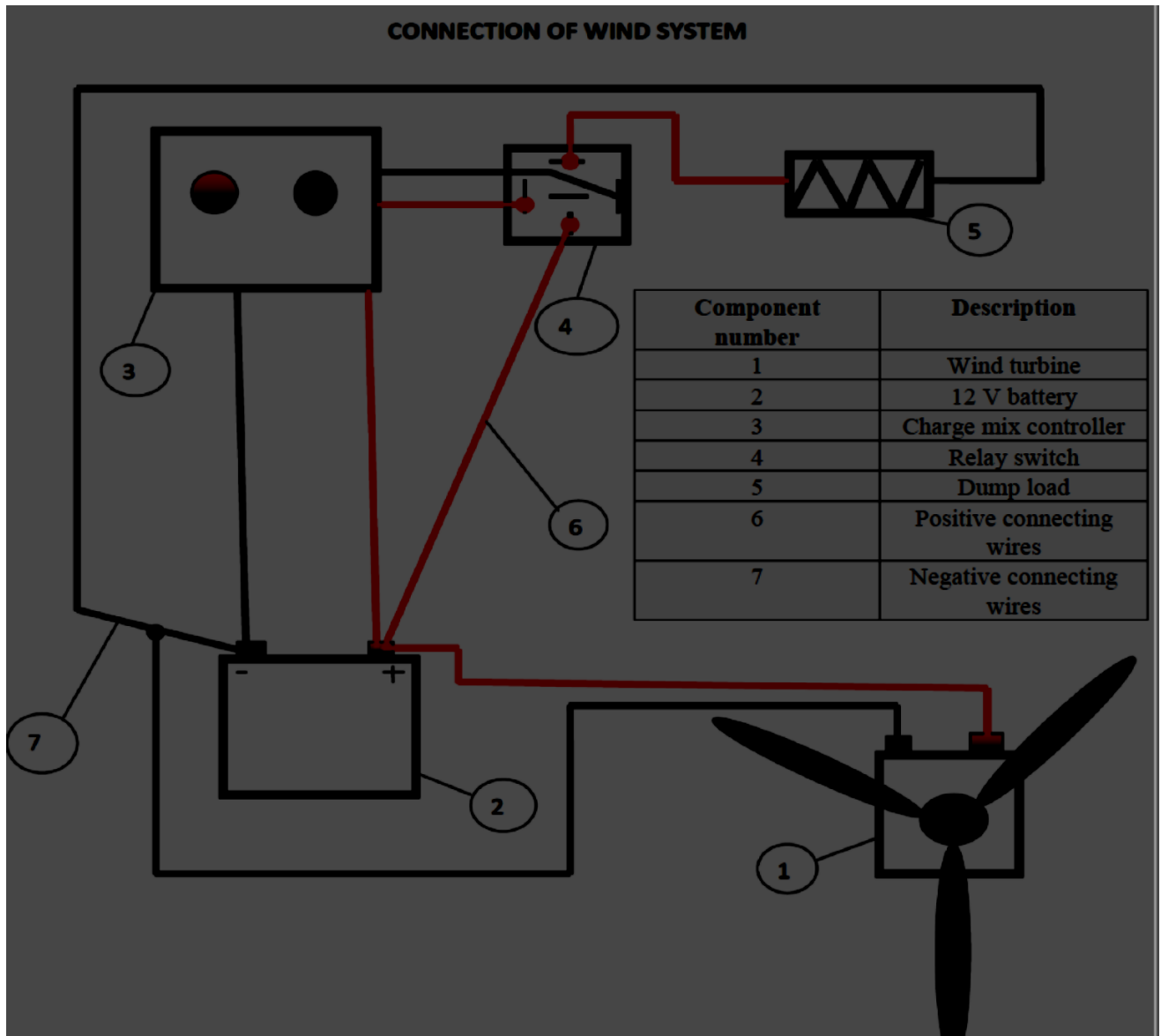

Figure 7.2: Connection of the wind system.

7.10 Testing of the full Hybrid System

Tests carried out on the hybrid device revealed that the hybrid generator operated successfully utilizing a combination of both wind and solar sources of energy at the same time, even though the two energy sources had different voltage characteristics, battery storage was successfully utilized to supply power to the whole system in moments of low supply from both sources. The setup and connection of the hybrid system is as shown in Figure 7.7, the testing as with the wind and solar individual components was done over a 12 hour period every day for one month. The voltage characteristics of the full hybrid system are highlighted further in chapter 8.

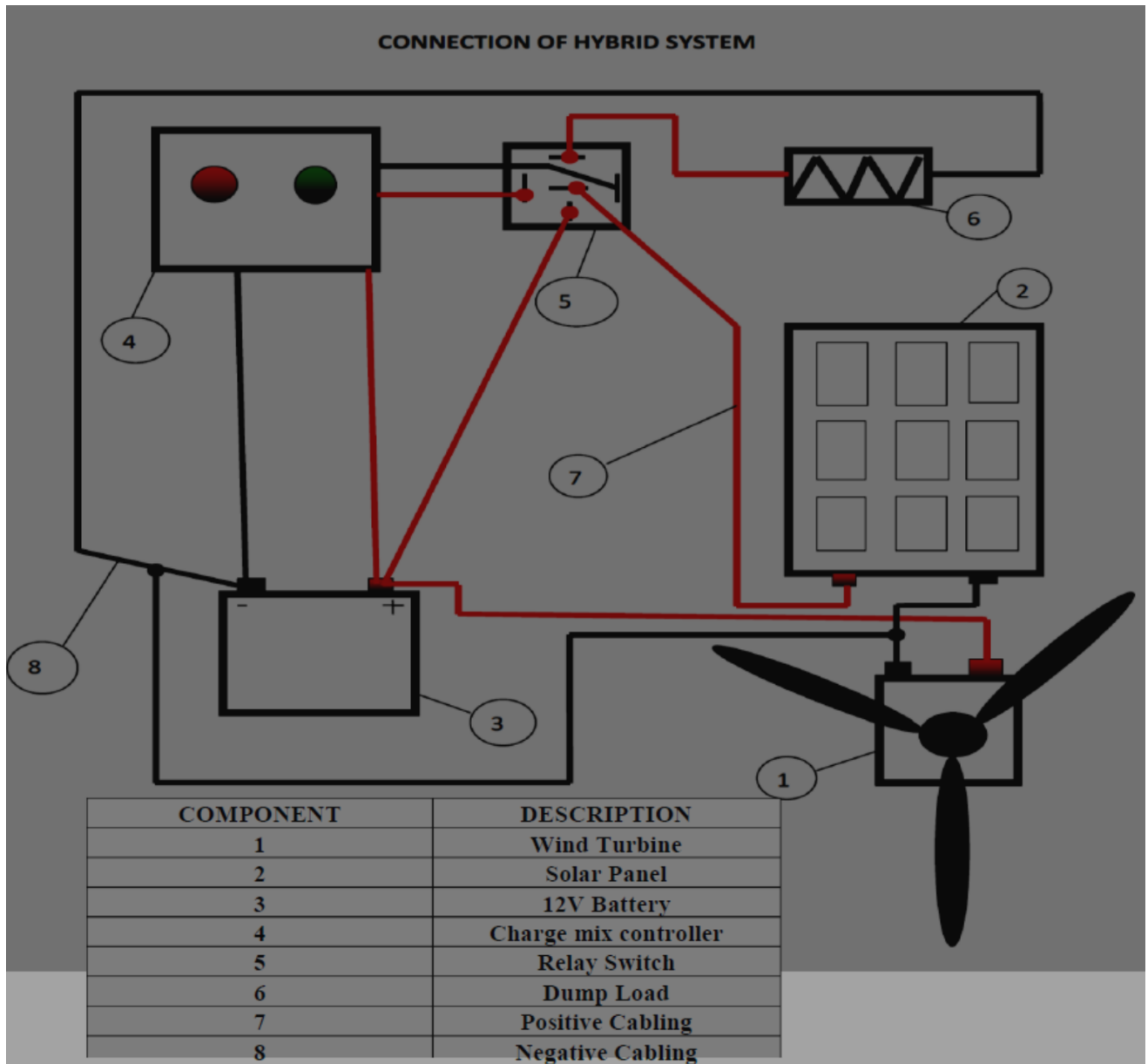

Figure 7.3: Connection of hybrid generator.

CHAPTER 8: RESULTS AND DISCUSSION

8.1 Introduction

This chapter looks at the results of the tests carried out on the wind/solar hybrid generator as outlined in chapter 7. The components of the hybrid were tested separately as well as in combination with all components connected and fully operational.

The results obtained from the simulation of the hybrid using Homer software are also shown here and finally a discussion of the results obtained during the actual tests and those obtained from the simulation are outlined, the implications of these results is also discussed.

8.2 Results

8.2.1 Solar PV component of the hybrid generator test results

The voltage characteristics curve obtained from tests carried out on the solar PV component of the hybrid generator as described in chapter 7 section 7.1 was as shown in *figure 8.1 (a)*. The solar component of the hybrid device showed a steady rise in voltage from 8 volts at 06:00 hours in the morning to a peak of about 18 volts at midday, this voltage again began to drop steadily until it reached a low of about 8 volts at 18:00 hours in the evening. With these voltage characteristics the solar PV generator was able to charge a 12 volt battery for most of the day.

8.2.2 Wind turbine component of the hybrid generator test results

The voltage characteristics curve obtained from tests carried out on the wind turbine component of the hybrid generator as described in chapter 7 section 7.2 was as shown in *figure 8.1 (b)*. The wind turbine component of the hybrid device showed a non-uniform behavior over the test duration, the voltage was observed to rise as high as 18 volts and drop to as low as 0 volts, this made it very difficult to predict the output which was rising and falling with the instantaneous wind speed. With the introduction of the electronic control, power converter and energy storage this voltage became more stable and the wind energy was able to charge the 12 volt battery and the electricity produced was able to power the cell phone battery chargers as required.

8.2.3 Energy storage component of the hybrid test results

The battery energy storage component of the hybrid device was tested as described in chapter 7 section 7.3 and the voltage characteristic curve is as shown in figure 8.1 (c). The voltage was observed to rise steadily from 12 volts to 12.6 volts which was the maximum set point on the electronic control system, this steady rise was between 06:00 hours and 08:00 hours, there after the voltage was maintained at 12.6 volts until around 17:00 hours when the battery experienced a slight drop in voltage to 12.5 volts. The battery was able to supply enough voltage to the cell phone chargers as required by design.

8.2.4 Full hybrid system test results

Tests carried out on the hybrid device revealed that the hybrid generator could operate successfully utilizing a combination of both wind and solar sources of energy at the same time, even though the two energy sources had different voltage characteristics. The setup and connection of the hybrid system was as described chapter 7 section 7.4 and the results are shown in *Figure 8.1 (d)*.

As observed in *Figure 8.1 (d)* the voltage was observed to rise steadily from the initial battery voltage minimum of 12 volts at 06:00 hours in the morning as both energy sources began to generate electrical power. The hybrid voltage rose steadily with the solar power as seen in figure 8.1 while the wind energy supplied high and low picks intermittently, this did not however affect the hybrid output as the electronic control was able to dump excess energy whenever the system was overloaded. The hybrid system voltage rose to a peak voltage 14.5 at which point the excess load was continuously dumped through the connected dump load.

The hybrid generator was able to disconnect the solar power component of the system whenever the dump load could not dump all the excess energy generated, this ensured the system was protected at all times. The test results as seen from figure 8.1 show that solar power and wind power can be used in hybrid form with the use of suitable electronic power conversion and control systems.

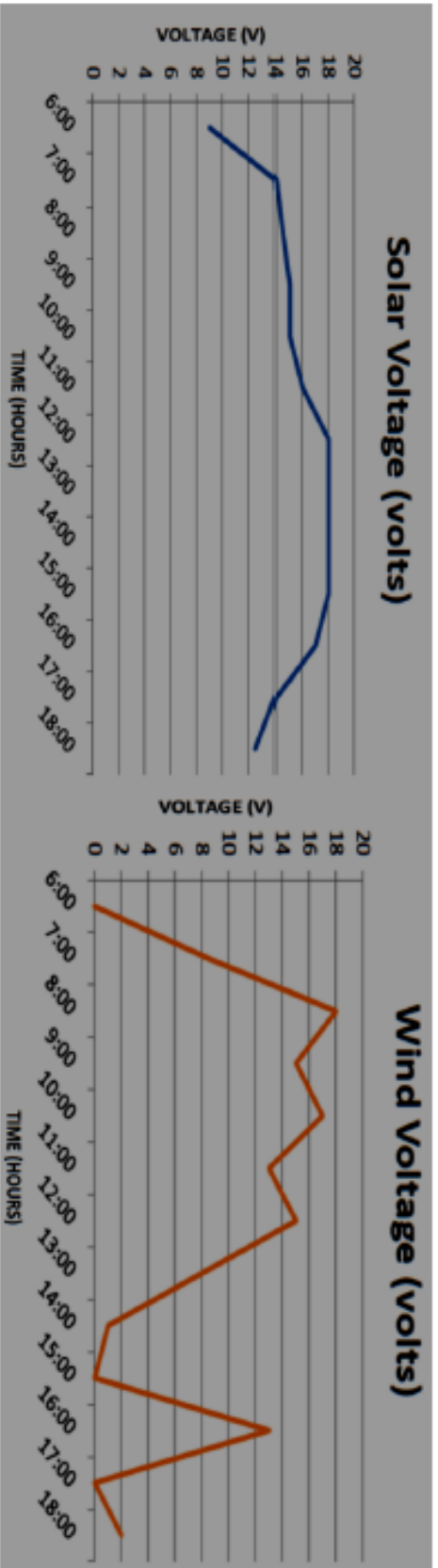

Figure 8.1 (a)

Figure 8.1 (b)

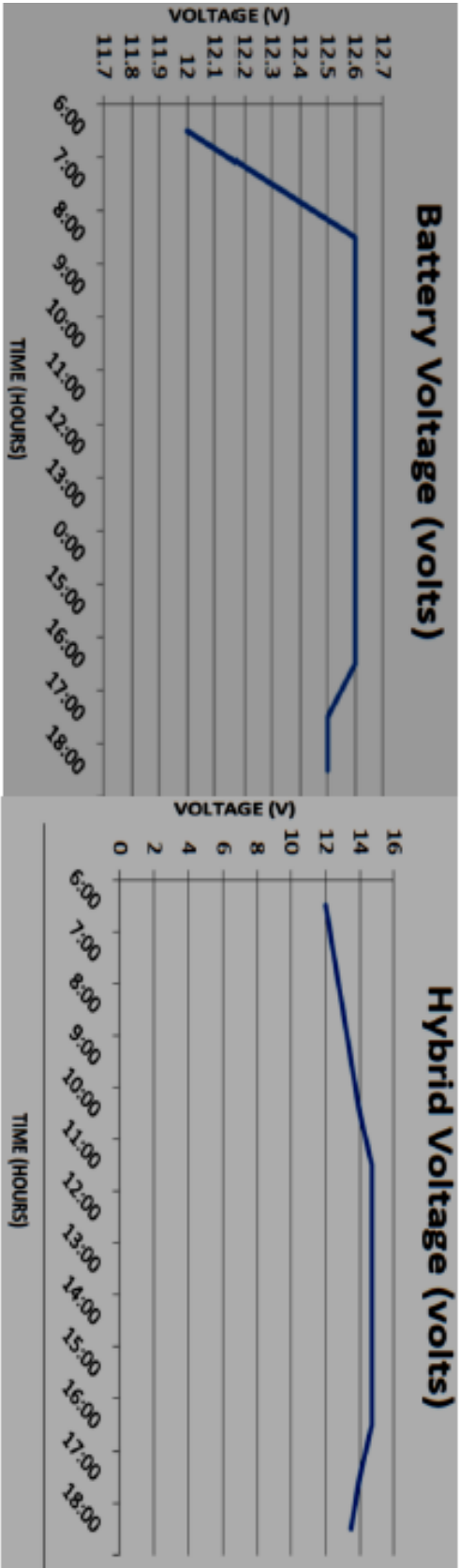

Figure 8.1 (c)

Figure 8.1 (d)

Figures 8.1 (a), 8.1 (b), 8.1 (c) and 8.1 (d) show the voltage characteristics of the solar PV generator, the wind turbine generator, the battery energy storage and the full hybrid power generator respectively. As can be seen from the figures the voltage characteristics of the hybrid are more stable than any of the individual inputs.

8.2.5 Simulation results

Using the simulation software homer, an electrical power generation analysis was done on the two electrical generators as shown in Table 8.1, it was found that due to the sizing of the components each source would contribute a certain percentage of the total power, it must be noted that the percent contribution of each source was dependent on the capacity of the component.

Figure 8.2 shows the simulated solar PV output between 06:00hrs and 18:00hrs over the course of the year, from the figure it is clear that the solar panel will be able to supply enough power as long as there was sunlight, the panel can also be used anywhere in Zambia since the conditions were favorable everywhere.

Table 8.1: Electrical contribution of each power source in percentages.

Component	Production (KWh/yr)	Fraction (%)
PV panel	135	34
Wind Turbine	253	63
Total	401	100

Figure 8.3 shows the wind turbine output over the course of the year, from the plot it is clear that wind energy is erratic and unevenly distributed over the course of the day but as unpredictable as it is, it can still be utilized successfully with the help of energy storage devices such as batteries which were used in this research.

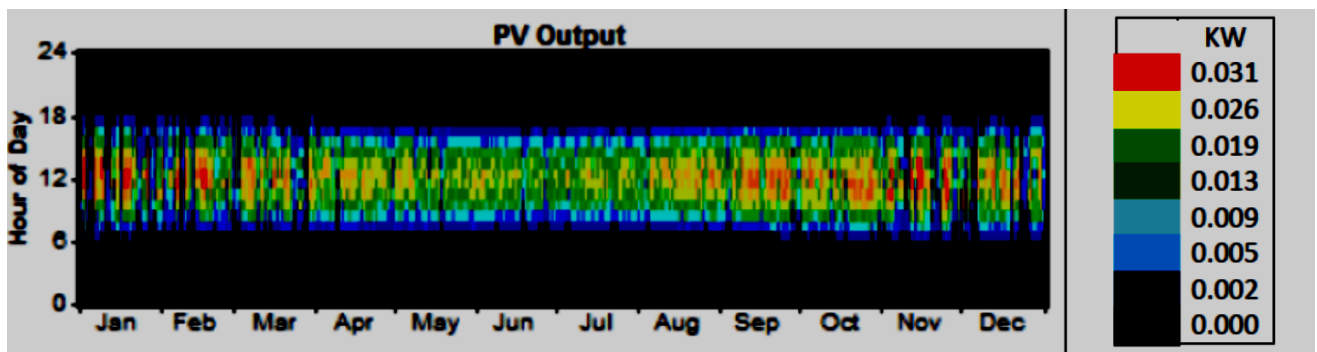

Figure 8.2: PV output distribution throughout the year.

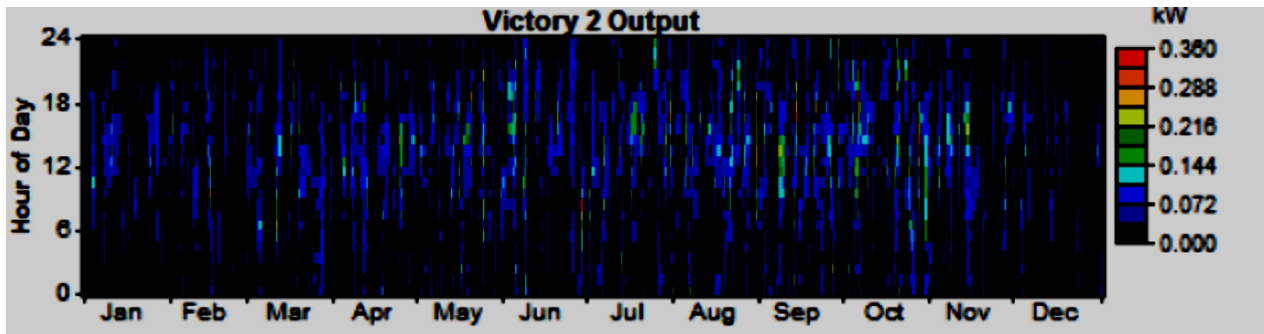

Figure 8.3: Wind turbine output distribution throughout the year.

Figure 8.4 shows the simulated battery state of charge or SOC, it is easy to see that the battery is able to maintain a good state of charge during the course of the year. Overall this is a good result as the hybrid supply is very dependent on the battery state of charge because it keeps the supply to the loads fairly constant and continuous. During the months of low charge, that is in March and April the energy storage capacity can be increased or the load on the system can be reduced. The inverter output is also seen to be fairly constant as shown in Figure 7.12, this was also observed in the testing phase and it was because of the mix controller which maintains a constant supply voltage to the inverter.

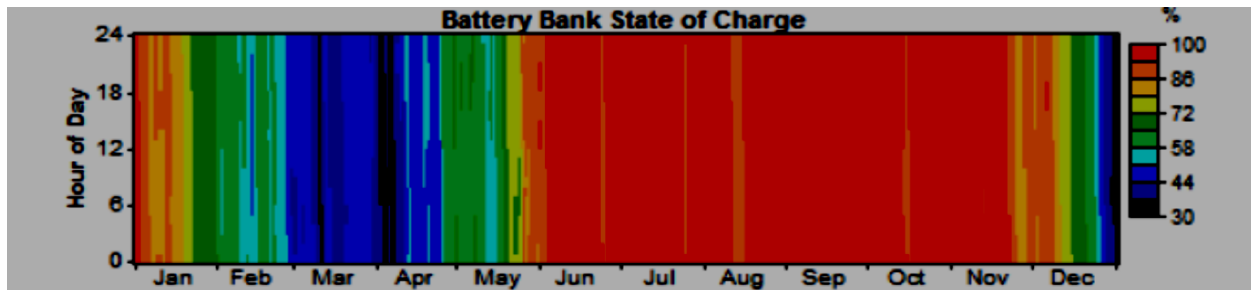

Figure 8.4: Battery state of charge throughout the year.

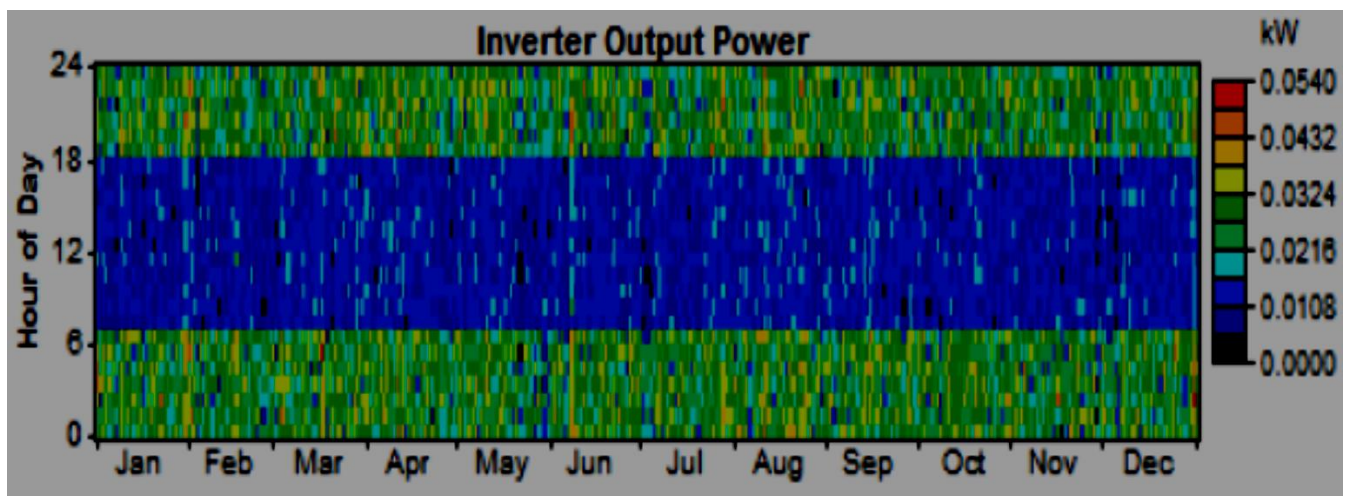

Figure 8.5: Converter output throughout the year.

At this point it is incomplete not to mention that the overall emissions of the hybrid system are virtually equal to zero as shown in the simulation results in Table 6.5, the only emissions are during the manufacturing phase of the project.

Table 8.2: Possible emissions in kilograms per year of each pollutant or greenhouse gas (GHG).

POLLUTANT	EMISSIONS (Kg/yr)
Carbon dioxide	0
Carbon monoxide	0
Unburned hydrocarbons	0
Particulate matter	0
Sulfur dioxide	0
Nitrogen oxides	0

Finally the simulation of the hybrid system operation over a monthly period for 1 year, showed good supply of electric power over the course of the year, this showed that the hybrid system was viable and could be used to power an off-grid site. The simulated results are shown in Figure 8.6. The months of January and February had the lowest simulated power production but this trend could still be altered by increasing the energy storage capacity for those particular months.

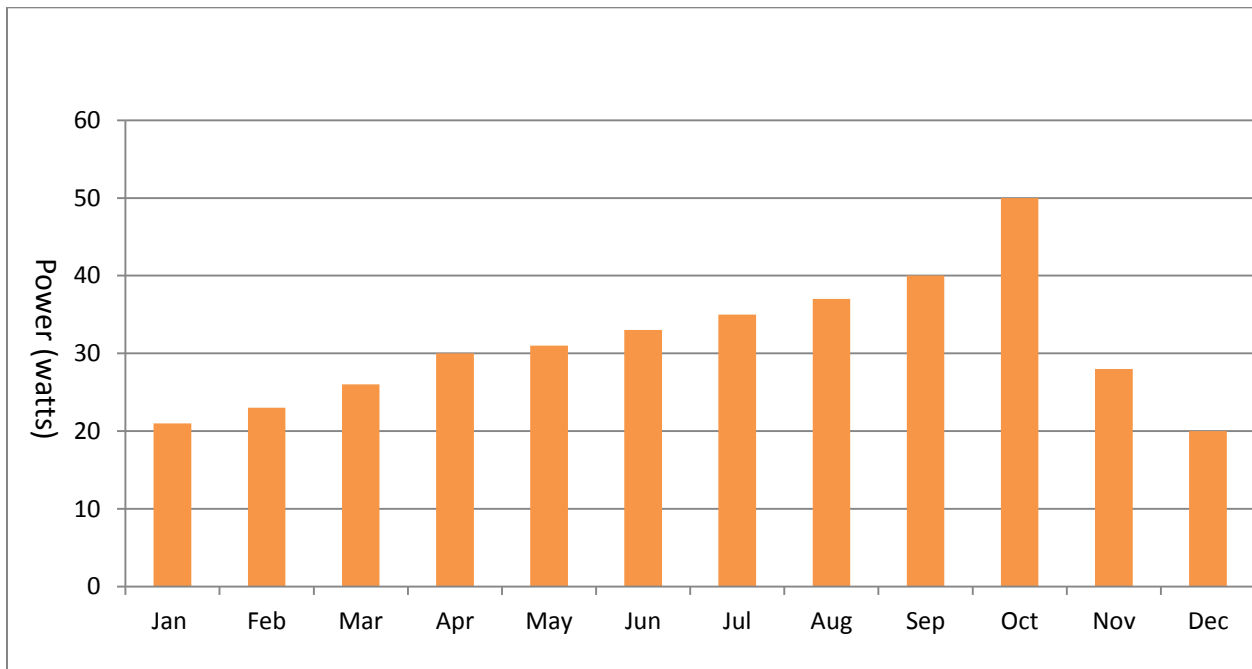

Figure 8.6: Simulated average monthly power production per month results for the hybrid system over a period of one year.

8.3 Discussion

The research and development (R &D) work was done successfully and it must be said that it was an interesting journey although the time and resources were limited.

The Solar PV generator which was sized at 31 watts worked very well as expected and contributed to the hybrid system successfully, the voltage characteristics of the Solar were observed to be very stable and the voltage increased gradually through the day until after midday when the voltage began to fall gradually. It was very easy to control the PV system as the energy storage kicked in to sustain the voltages when the solar voltages dropped below battery voltage. The electronic control system proved to be very effective in times of excess supply from the solar system.

The wind turbine generator was sized for generating up to of 770 watts depending on the wind speed, the wind turbine unlike the solar component was observed to have a very erratic voltage characteristic which was also very unpredictable. The highest winds during the day were observed between the hours of 09:00hrs and 15hrs everyday although the turbine could work at any time of the day depending on the prevailing wind speeds.

Furthermore the wind turbine blades which are some of the most important components of the hybrid system, were designed and manufactured using the NACA 2412 airfoil profile at a thickness of 20mm. the choice of the NACA 2412 type airfoil was critical as it enabled the use of an eight inch PVC pipe to manufacture the blades very quickly and cheaply. The blades also proved to be very effective and were able to ensure a cut in speed of about 3.1 m/s for the wind turbine.

During the research and development work much of the manufacturing work concentrated on the wind turbine system as the other components were sized and procured off the shelf, the work on the wind turbine also included the design of the mounting pole and frame for the entire wind turbine system. The turbine was observed to work very well at a height of ten meters or more above ground. Photos of the wind turbine mounted at the School of Engineering roof top are attached in appendix 2.

The energy storage component of the wind turbine which utilized a battery also proved to be very effective; the battery was able to ensure a 12 volt supply voltage in times of low or erratic supply for both the wind and solar resources. The voltage characteristics of the battery storage proved to be very stable and reliable.

The electronic component of the hybrid system which includes the charge mix controller, a relay switch, dump loads and an inverter proved to be very effective in the control and stabilization of the voltage supplied to the loads. The electronic controls were able to make sure the voltage was kept in the set points 12 to 14.7 volts.

The simulation results obtained using Homer software version 2.81 revealed that the project was actually viable and could be done successfully. The results also showed that although wind and solar

can actually be used independently, there are more advantages and induced stability when they are used as a hybrid technology. Furthermore the energy generated from the renewable resources was observed to be intermittent or erratic most of the time and this underlined the need for energy storage. The type of energy storage used in this research was a 12 volt battery and this smoothed out the voltage supply which was seen to be between 12 volts and 14.7 volts.

Furthermore the simulation results obtained could still be improved by using a specified time period of 12 or 24 hours this would allow for better analysis and tallying with the actual results obtained from tests. The most recent Homer software can be used to achieve even more accurate and realistic results which can allow for optimization of the actual design.

The results from the simulation and the actual testing of the hybrid showed that the system can actually be used successfully to power an off-grid site.

This research overall has shown that the hybrid setup provides a high level of energy security and that coupled with energy storage namely; the battery, maximum supply reliability and security was ensured. The hybrid system due to the said advantages can be used as main power supply in off grid households, as standby supply in grid connected systems or as part of the grid system to offer more security.

CHAPTER 9: CONCLUSIONS AND RECOMMENDATIONS

9.1 Conclusions

9.1.1 Introduction

With the increase in global energy demand, the introduction of excessive load shading and fuel price increases in Zambia, the search for safe, clean and renewable energy has become one of the top national issues of discussion. Overcoming the challenges associated with high energy demand implies that we should use maximum renewable energy of the earth such as wind and solar.

This chapter deals with the conclusions drawn from the design manufacture and testing of the hybrid wind /solar generator, it shows that the main objective of the research as outlined in chapter 1 was met successfully. The chapter further shows that the specific objectives also outlined in the first chapter were met successfully.

As a recap from the first chapter, the main objective of this research project was to design, manufacture and test a 3-blade Wind Turbine/Solar PV hybrid generator for powering an off-grid site for charging cellular phones. The specific objectives of the research were:-

1. To Analyze weather data in relation to wind speeds and solar insolation in Zambia and this was used for the development of an optimal design of a Wind /Solar Hybrid generator for charging cell phones;
2. To design and manufacture a prototype Wind/Solar based charger system suitable for charging batteries that were to be used to power an off-grid site.
3. To design an electronic converter system linking wind and solar power for the Hybrid system;
4. To size and design a suitable energy storage system for the generator;
5. To conduct prototype tests on the wind solar hybrid system so as to analyze and optimize the design.

9.1.2 The Solar PV Generator

The Solar PV generator sized at 31 watts was observed to have a stable power output as outlined in the chapter 8 in the test period of between 06:00 and 18:00 hours, in the same period the Solar insolation observed was at an average of above 5KWh/m²/day for most of the day, this figure was higher than 1KWh/m²/day which is used under standard test conditions. The voltage obtained from actual tests ranged from 10 – 19 volts which was more than enough to charge a battery and charge the cellular phones. The only constraint to obtaining more power was the size of the Solar PV panel itself, with a bigger size PV panel more power can be generated and used for loads requiring much more electric power.

9.1.3 The Wind Turbine Generator

The three blade Wind turbine sized at 700Wh was easily able to produce more than enough power to charge the battery and the cellular phones. The turbine which was also tested in the same period was able to produce up to 20 volts although this voltage was always fluctuating and was very unpredictable and erratic. Nevertheless the power produced was successfully harnessed and stored using energy storage and electronic control.

The blades used in this case the NACA 2412 type airfoil blades produced from PVC pipe proved to be very effective, the blades ensured that the cogging effect of the generator used was sufficiently and effectively overcome at a wind speed of around 3.1m/s. the blades where able to still overcome this torque at wind speeds of as low as 2m/s after cut in. The blades whose advantage is the ease of manufacture and simplicity in design presented a lot of cost saving opportunities and eliminated the need for specialized equipment and skilled manpower.

9.1.4 The Battery as Energy Storage

The battery which was used for energy storage proved to be very effective and could store enough charge to cater for low generation periods, the battery was able to charge to the required 12V and was able to hold the charge at 12V throughout the test period. The battery which was cheap and simple in construction added the advantage of very little maintenance and was very easy to connect for use with both the wind and solar and also in hybrid format. The excess was either used directly to charge the cell phones or was dumped via a dump load connected in the circuit, and this showed that there was need for more energy storage to avoid waste of generated electrical energy.

9.1.5 The Electronic Control System

The electronic control system which consisted of the Charge Mix Controller, the Dump Load, a Relay Switch and an inverter was designed to control the supply voltage between 12 and 14.7 volts. The control system was able to maintain the circuit voltage in the required range, switching between the storage and generation systems when was required to, the system was able to dump the excess load when need arises. The control system was also able to switch off generation when the power generated exceeded the rated power of the components in question, this was very critical and showed that the power generated could be used in a grid tied system.

9.1.6 The Hybrid System

The mechanical and electrical energy produced by wind energy using wind turbines and solar using solar PV panels has proved to be very useful and even though they are erratic and intermittent in nature with the use of energy storage and electronic controls, they can still be utilized successfully.

It can be said that the work set out in this research and development work was done successfully, the hybrid wind/ solar generator was designed, manufactured and tested successfully as was set out in the main objective.

A simulation done on the system revealed that the hybrid was a viable option for the specified requirement. The simulation which was done using the software Homer version 2.81 showed very good characteristics throughout the with the lowest generation expected in the months of December and January, however it was discovered that by increasing the energy storage capacity this anomaly could be easily eliminated.

The weather data was studied and researched thoroughly and it was found that it was very suitable and the hybrid could be used with a few improvements, virtually anywhere in Zambia.

Furthermore the hybrid was tested and used successfully for the intended purpose of charging cellular phones proving that the technology can actually be used for much bigger purposes like powering a house or off-grid buildings, it was also noticed that because of the good characteristics induced by the electronic control system the hybrid could also be used in grid tied applications.

9.2 Recommendations

Although the hybrid generator was designed for optimum performance, there was still need to further improve and optimize the design to produce and store more electrical energy. Further performance improvement can be achieved by:-

1. Replacement of the generator with a low cog type, this will reduce the cut-in speed of the wind turbine and will mean that the wind turbine is able to operate over a larger range of wind speeds and effectively increase the amount of energy it can generate.
2. Development of an automatic furling system for the wind turbine, this will protect the wind turbine from excessive winds as well as keep the turbine in the wind so that it can collect as much energy as required.
3. A gear box could be employed to increase the speed of rotation of the generator and hence the energy produced by the turbine could be increased as desired. This is a very good option although some of the energy may be lost during transmission
4. Another option on the wind turbine could be increasing the height of the turbine; this enables the turbine to collect more wind and further eliminates interference from the surroundings.
5. Other NACA type airfoils can be tested in the Zambian wind regime as well.
6. There is a lot that can be done on the solar system as well; this includes the use of trackers to make sure the solar panel captures enough sunlight at any time of day.
7. Other more efficient types of solar panels can be employed for this purpose.
8. Simulation of the design using the latest homer simulation software to achieve much better and more realistic results.

REFERENCES

1. Airfoiltools (2015). *Design of NACA 2412 Airfoils*. [Online]Available from: <http://airfoiltools.com> (accessed 3rd January 2015)
2. Burch G.D. (2001) *Hybrid power systems*, Hybrid Renewable Energy Systems. U.S. Department of Energy.
1. Chisale P. (2014) *Renewable energy cycle*. Bioenergy System. REE 6182. The University of Zambia.
3. Darling D. (2015). *Principles of Wind Turbine Aerodynamic Lift*. [Online]Available from: http://www.daviddarling.info/encyclopedia/H/AE_horizontal-axis_wind_turbine.html (accessed 3rd December 2015)
4. ENERGY.GOV. (2015) *Hybrid Wind and Solar Electric Systems*. [Online]Available from: <http://energy.gov/energysaver/articles/hybrid-wind-and-solar-electric-systems>. (accessed 3rd December 2014)
5. Flickr Photos. (2015) *Renewable Energy Sources*. [Online]Available from: <https://www.flickr.com/photos/goodmagazine/3905443690> (accessed 14th January 2015)
6. Garg H.P. and Prakash J. (2007) ***Solar Energy - Fundamentals and Applications***, Tata McGraw-Hill, New Delhi, India, ISBN 0-07-463631-6.
7. Homer Energy. (2010) *Hybrid Renewable Energy Systems Software*, version 2.81. [Online]Available from: <http://www.homerenergy.com/>
8. International Energy Agency. (2009) *World Energy Outlook, 2013*.
9. International Energy Agency. (2009) *World Energy Outlook 2009*.
10. International Energy Agency. (2005) *World Energy Outlook, 2005*.
11. Jain P. (2010) *Wind Energy Engineering*, 1st Ed., McGraw-Hill Professional, ISBN-10:0071714774, ISBN-13: 978-0071714778.
12. Masters G.M. (2004) *Renewable and Efficient Electric Power Systems*, John Wiley & Sons, Hoboken, New Jersey, USA: ISBN 0-471-28060-7
13. Mwenda, H. M. (2014) *Types of wind turbines*. Wind Energy. REE 6172. The University of Zambia.
14. Mwenda, H. M. (2014) *How wind is created*. Wind Energy. REE 6172. The University of Zambia.
15. Mwenda, H. M. (2014) *Calculations in wind turbines*. Wind Energy. REE 6172. The University of Zambia.
16. Missouri Wind and Solar. (2014) *characteristics of a 700 watts permanent magnet generator*.
17. Mwenda, H. M. (2014) *NACA type airfoil families*. Wind Energy. REE 6172. The University of Zambia.
18. Mwenda, H. M. (2014) *Average wind speeds in Zambia from the Meteorological Department of Zambia*. Wind Energy. REE 6172. The University of Zambia.
19. Mwanza, M. (2014) *Control systems*. Wind Energy. REE 6172. The University of Zambia.
20. Mwanza, M. (2014) *Types of generators used in wind turbines*. Wind Energy. REE 6172. The University of Zambia.

21. Mwanza, M. (2014) *Variation of wind speeds with height above ground*. Wind Energy. REE 6172. The University of Zambia.
22. Suryodaya Urja Pvt. Ltd. (2008) *Solar PV Systems*. [Online]Available from: <http://www.suryodayaurja.com/products-solutions/solutions/soar-home-lighting-systems>
23. Turbines Info. (2014) *Parts of HAWTs*. [Online]Available from: <http://www.turbinesinfo.com> (accessed 30th December 2014)
24. Piggott H. (2003) *How to Build a Wind Turbine*, Scoraig Wind UK.
25. Robinson J and Van Bers C. (1996) *Living Within Our Means: The Foundations of Sustainability*. David Suzuki Foundation, Vancouver, BC.
26. Tangler J. L. and Somers D.M. (1995) *NREL Airfoil Families for HAWTs*, National Renewable Energy Laboratory. U.S. Department of Energy.
27. Weatherspark. (2015) *Average hourly weather for Lusaka*. [Online]Available from: <https://weatherspark.com/averages/29089/Lusaka-Zambia>
28. Witherden M. (2003) *Renewable Energy Report*. [Online]Available from: <http://witherdens.com/finalx2.htm> (accessed 18th January 2015)
29. Zulu, A. (2014) *Energy storage*. Solar Energy. REE 6021. The University of Zambia.
30. Zulu, A. (2014) *The solar resource*. Solar Energy. REE 6021. The University of Zambia.
31. Zulu, A. (2014) *Distributed energy systems*. Energy Systems and Sustainability. REE 6052. The University of Zambia.

APPENDICES

APPENDIX 1: DRAWINGS

Drawing 1: The blades.

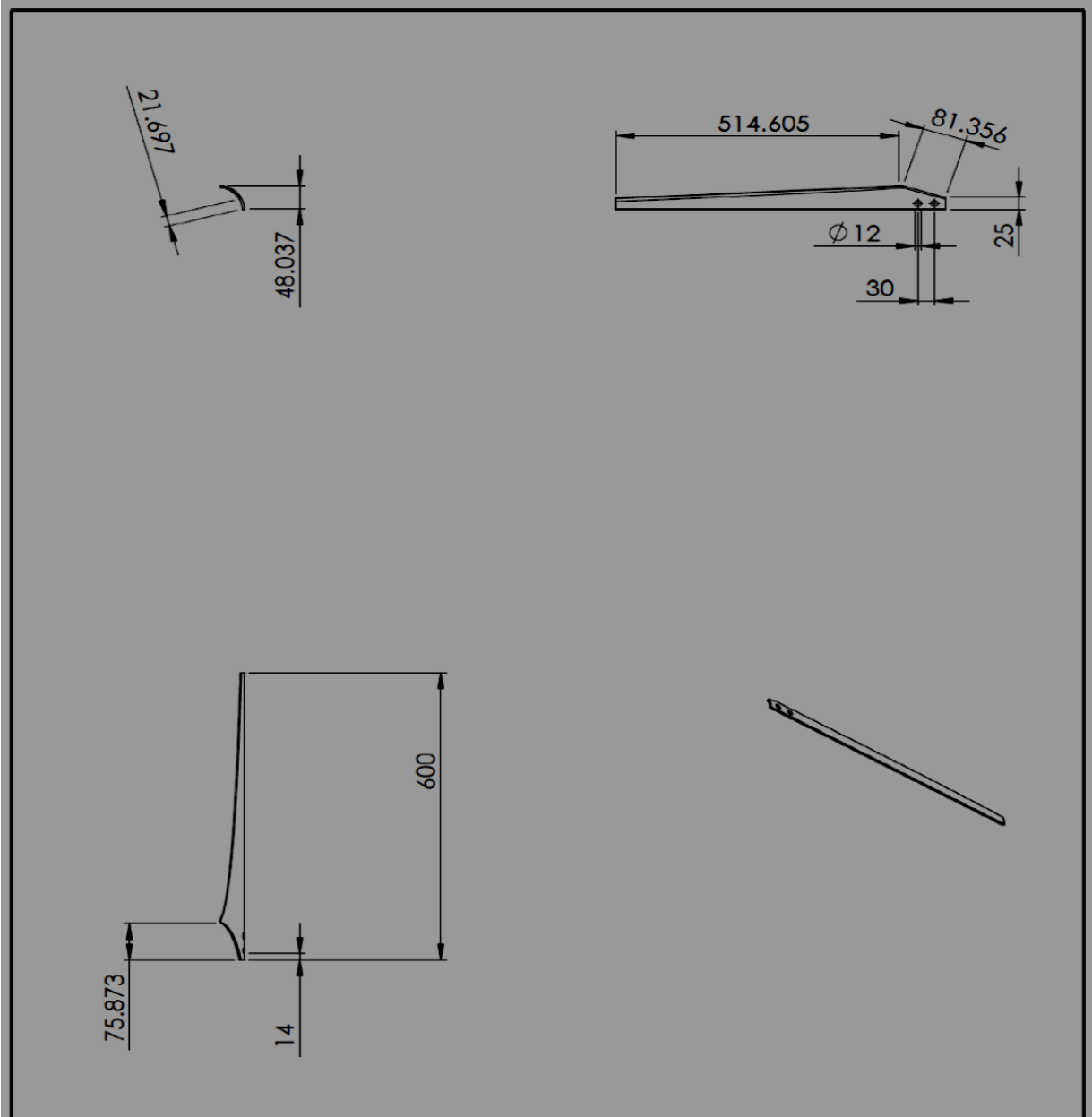

UNLESS OTHERWISE SPECIFIED: DIMENSIONS ARE IN MILLIMETERS SURFACE FINISH: TOLERANCES: LINEAR: ANGULAR:				FINISH:		DEBUR AND BREAK SHARP EDGES		DO NOT SCALE DRAWING		REVISION	
DRAWN:				SIGNATURE		DATE		TITLE: Hybrid Drawings			
CHK'D:								DWG NO. Final blade drawing A4			
APP'VD:											
MFG:								SCALE: 1:10			
Q.A.											
				MATERIAL: PVC				SHEET 1 OF 1			
				WEIGHT:							

Drawing 2: Blade Mounting Hub.

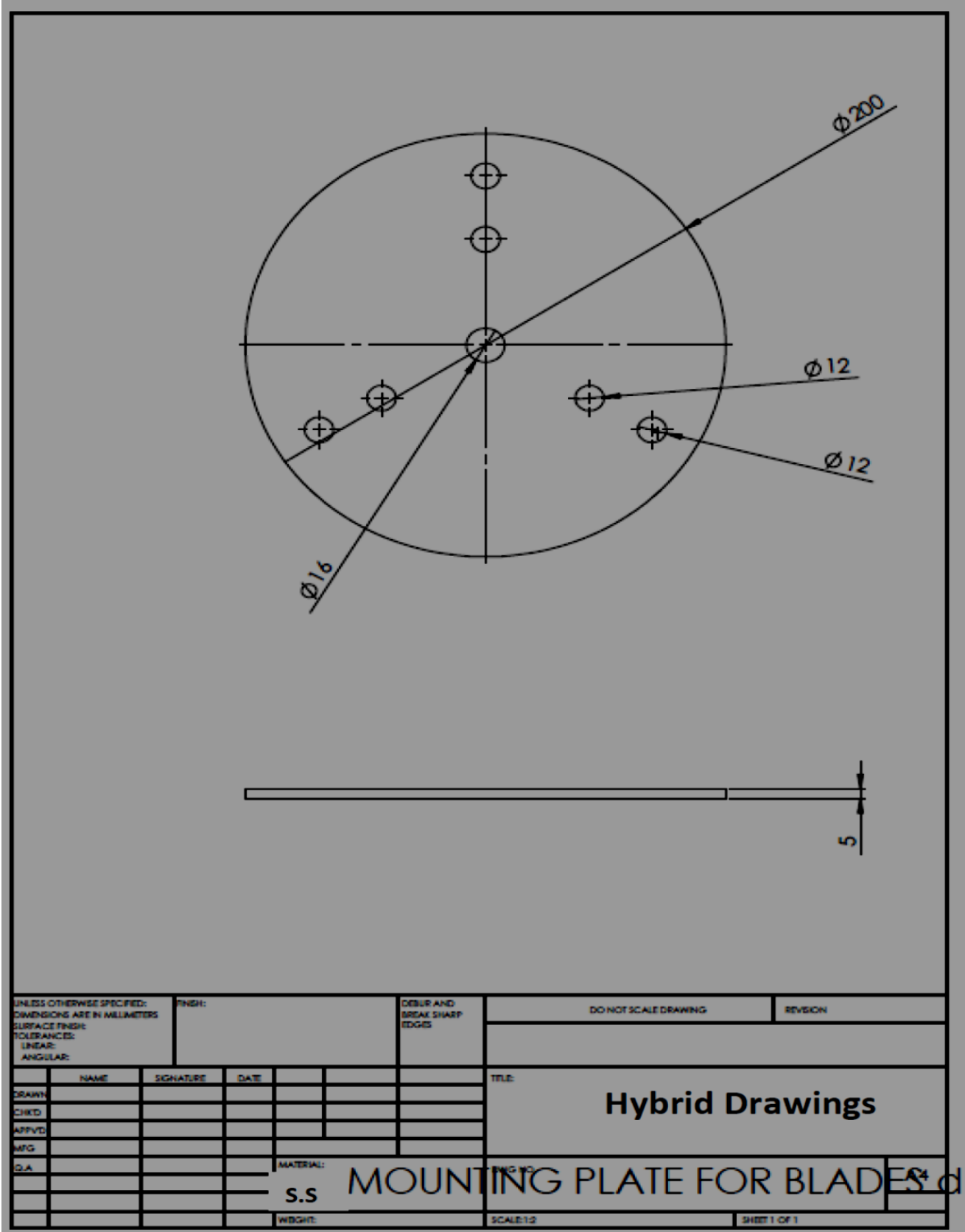

Drawing 3: Motor Bracket.

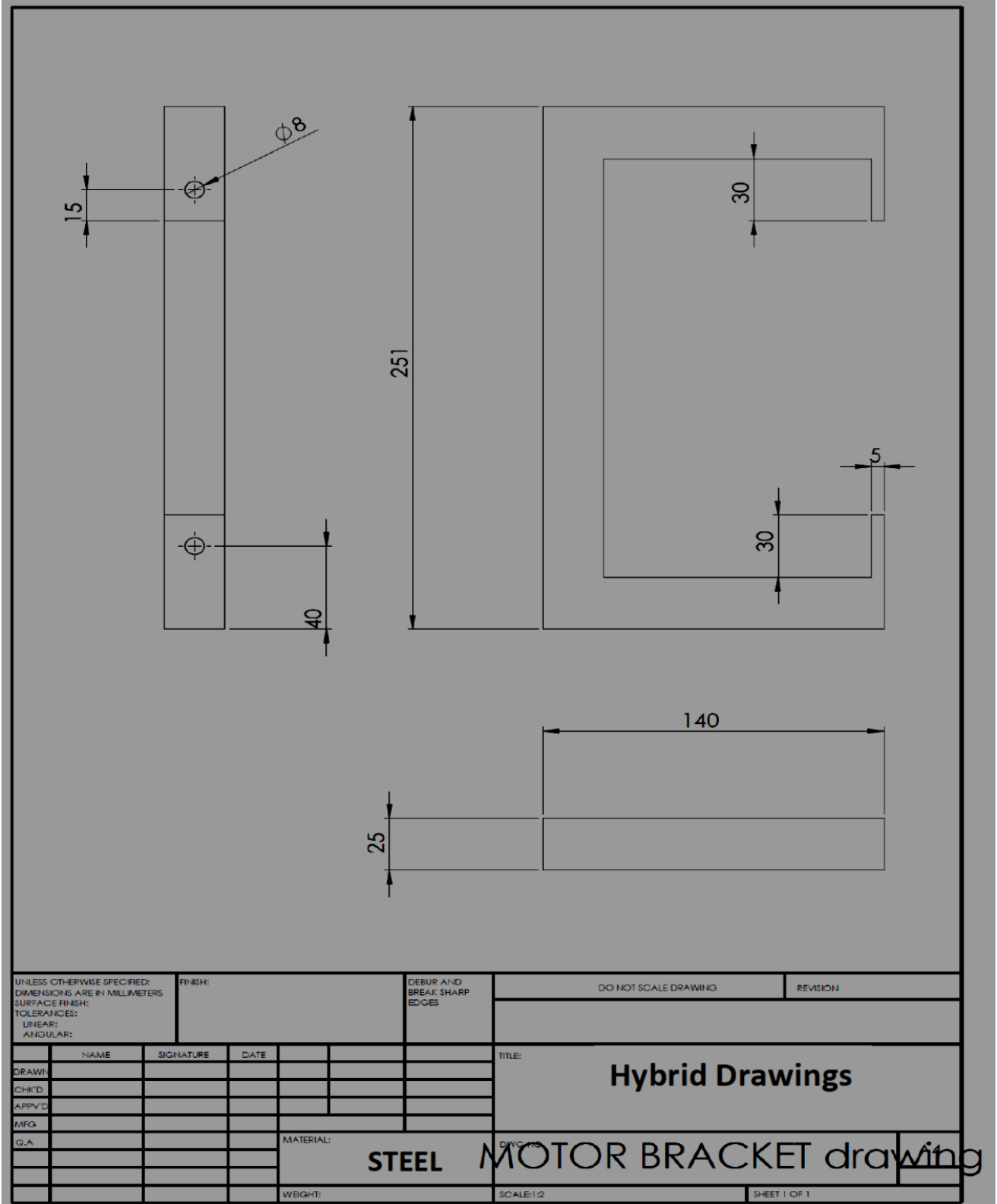

Drawing 4: Blade Hub Assembly.

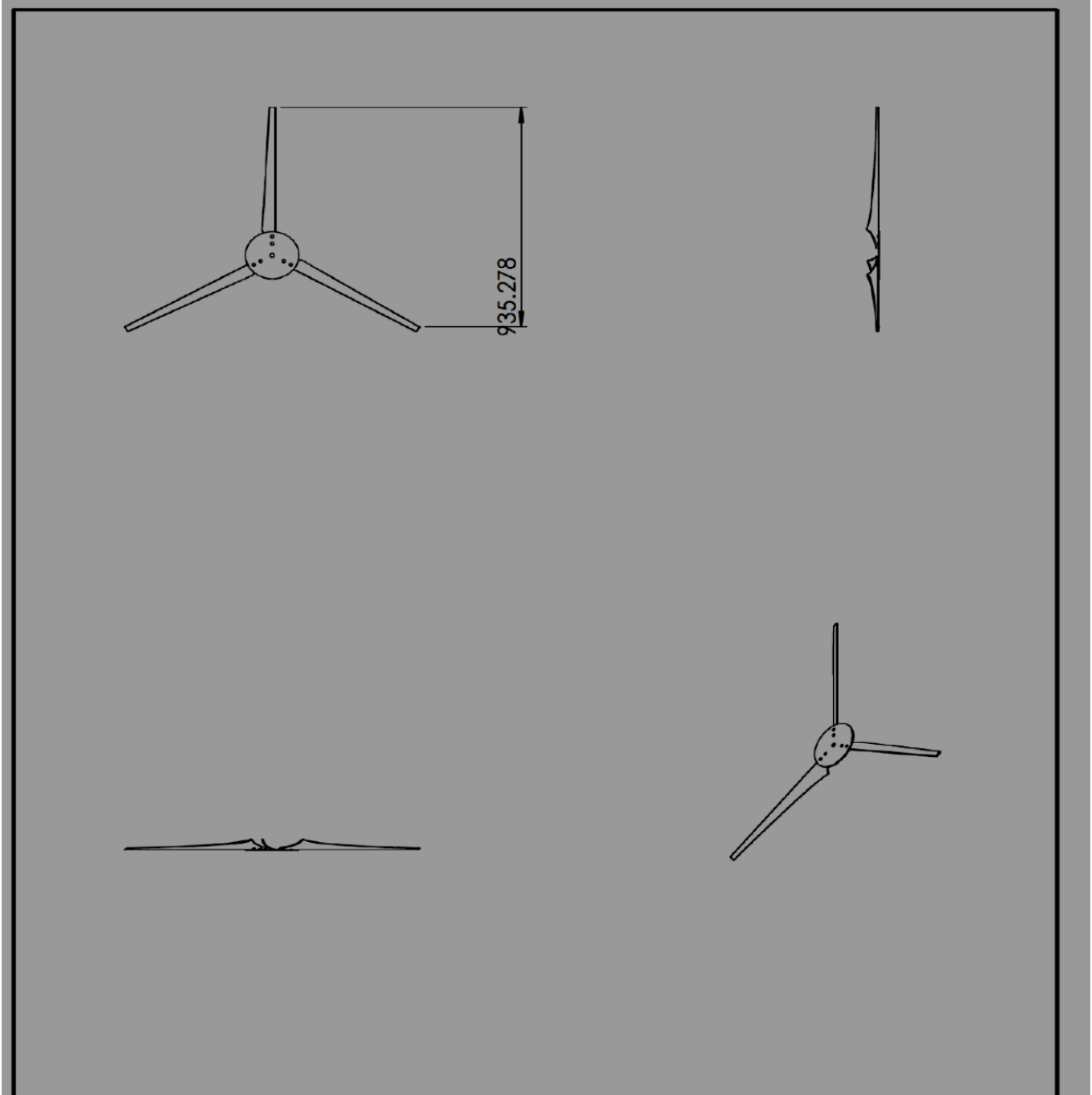

UNLESS OTHERWISE SPECIFIED:
DIMENSIONS ARE IN MILLIMETERS
SURFACE FINISH:
TOLERANCES:
LINEAR:
ANGULAR:

FINISH:

DEBUR AND
BREAK SHARP
EDGES

DO NOT SCALE DRAWING

REVISION

	NAME	SIGNATURE	DATE		
DRAWN					
CHK'D					
APP'D					
MFG					
Q.A					

TITLE: **Hybrid Drawings**

STEEL blade hub assembly drawing

DWG. NO. 144

SCALE: 1:20

SHEET 1 OF 1

Drawing 5: Bearing Hub.

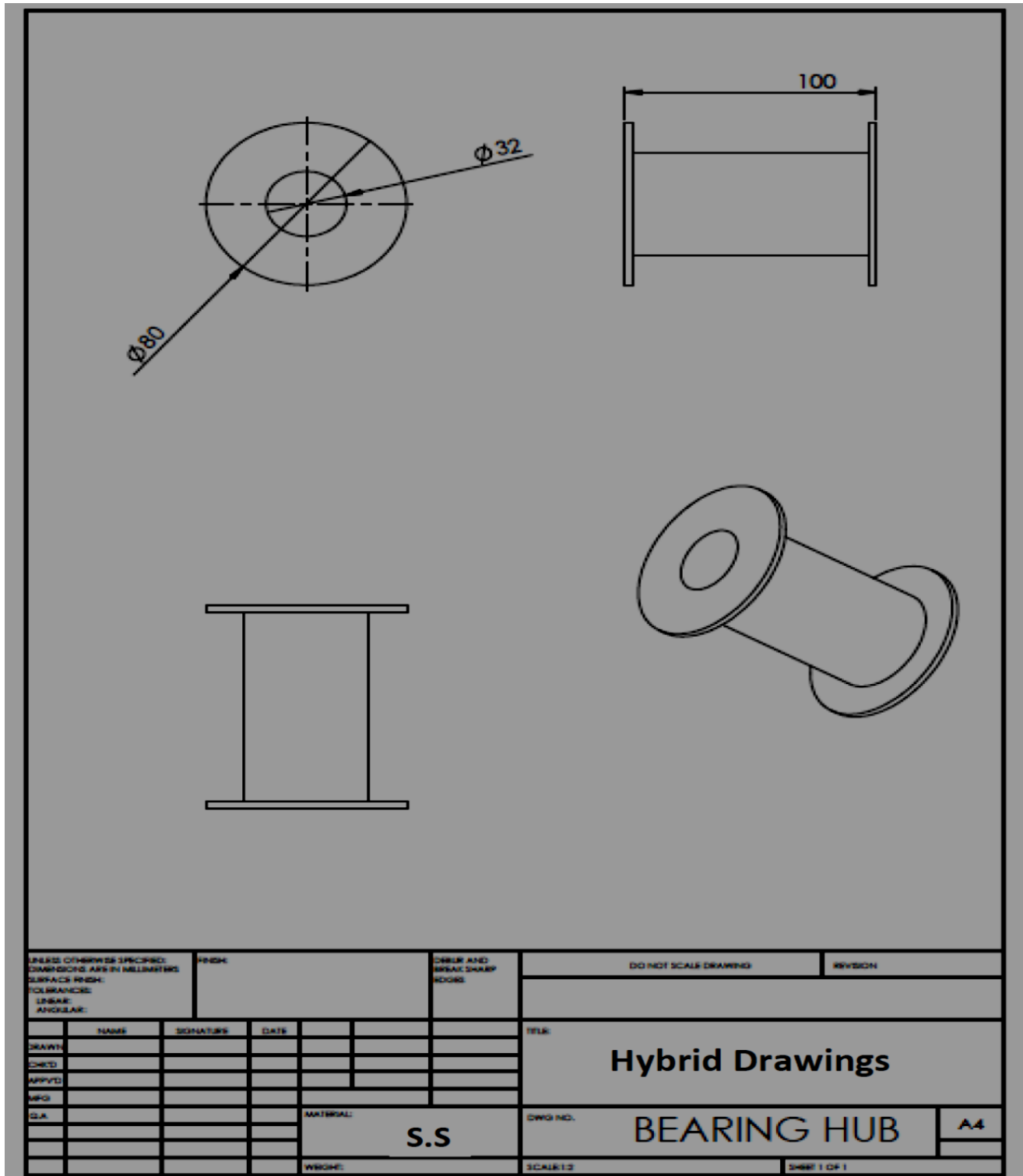

Drawing 6: Tail piece.

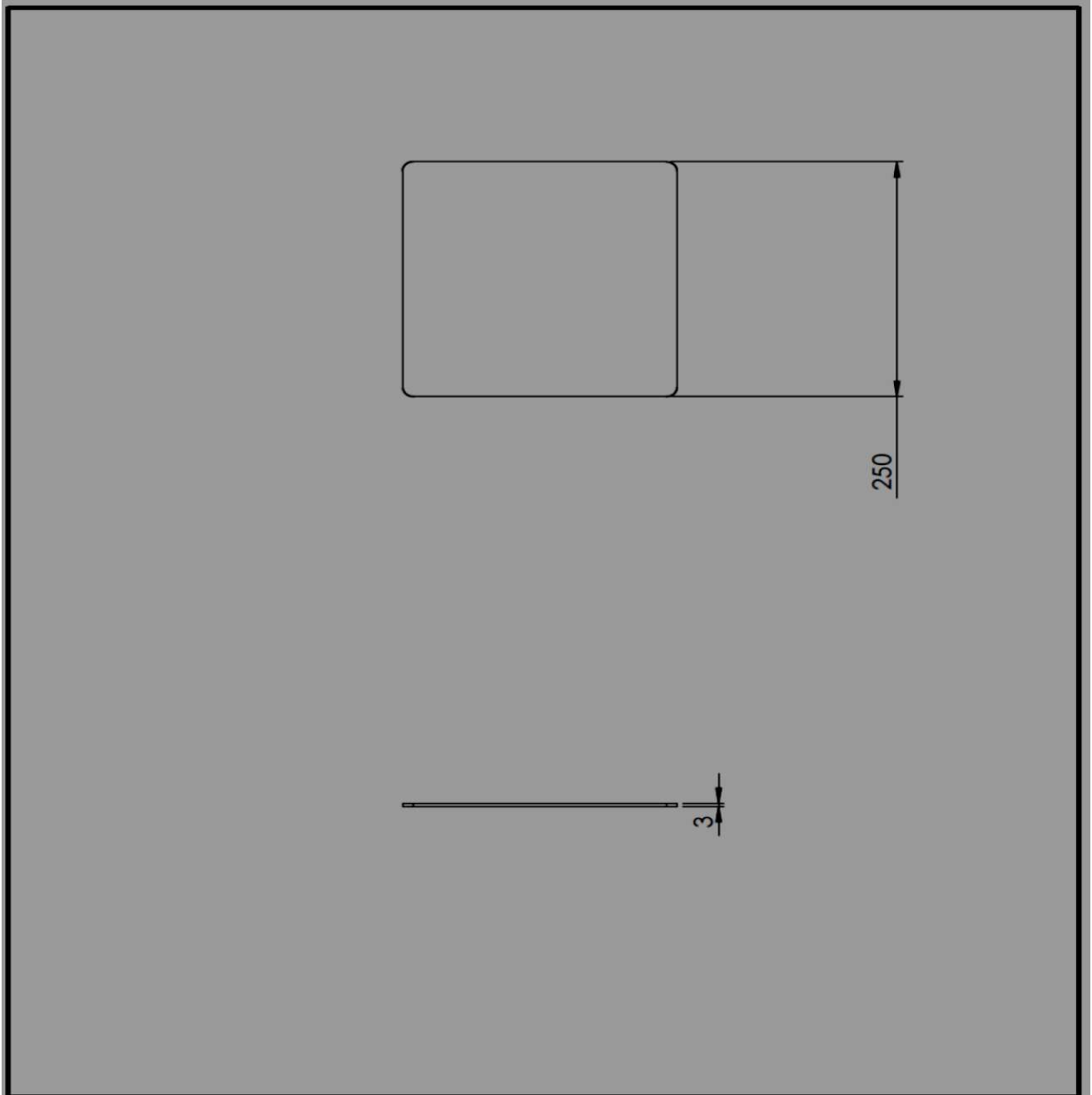

UNLESS OTHERWISE SPECIFIED: DIMENSIONS ARE IN MILLIMETERS SURFACE FINISH: TOLERANCES: LINEAR: ANGULAR:				FINISH:		DEBUR AND BREAK SHARP EDGES		DO NOT SCALE DRAWING		REVISION	
DRAWN:				SIGNATURE		DATE		TITLE: Hybrid Drawings			
CHKD:								DWG NO. TAIL PIECE			
APPVD:											
MFG:								SCALE:1:3			
G.A.											
						MATERIAL: Steel					
						WEIGHT:					

APPENDIX 2: PHOTOS



Figure A2.1: The Wind Turbine.



Figure A2.2: The Solar Panel, Converters and the Battery.



Figure A2.3: The Hybrid being mounted at the School of Engineering.



Figure A2.4: The Hybrid in action at the School of Engineering.